

## GENERAL DESCRIPTION

The HP4056 is a complete constant-current/ constant voltage linear charger for single cell Lithium-Ion batteries. No external sense resistor is needed, and no blocking diode is required due to the internal MOSFET architecture. The charge voltage is fixed at 4.2V or 4.35V, and the charge current can be programmed externally with a single resistor.

The HP4056 automatically terminates the charge cycle when the charge current drops to 1/10 the programmed value after the final float voltage is reached.

When the input supply (wall adapter or USB supply) is removed, the HP4056 automatically enters a low current state, dropping the battery drain current to less than 0.1uA.

The HP4056 is available in ESOP-8 package. Standard product is Pb-Free & Halogen-Free.

## FEATURES

- Programmable Charge Current Up to 1A
- Under Voltage Lockout Protection
- 150mV(Typ.) Automatic Recharge Threshold
- Charge Status Output Pin
- 2.9V Trickle Charge Threshold
- Soft-Start Limits Inrush Current

## APPLICATIONS

- Feature Phone
- MP3/MP4 Players
- Electric Toy
- Bluetooth, wireless handsets
- Others portable electronic device

## MARKING DESCRIPTION

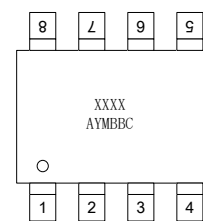

“XXXX”: Part number  
 “A”: Internal Control Code  
 “Y”: Year code “M”: Month code  
 “BB”: Order serial number  
 “C”: Version number

## ORDERING INFORMATION

Device	V <sub>FLOAT</sub>	Package	Temperature	Tape&Reel
HP4056E8-42	4.2V	ESOP-8	-40 ~ +85°C	4000/Reel
HP4056E8-435	4.35V	ESOP-8	-40 ~ +85°C	4000/Reel

## TYPICAL APPLICATION CIRCUIT

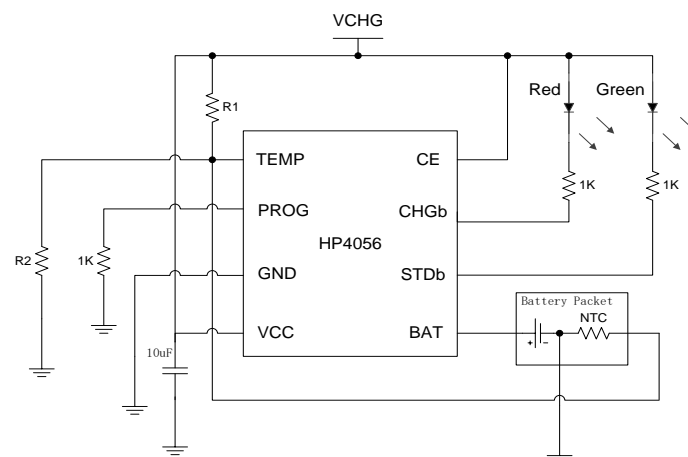

## PIN ASSIGNMENT



ESOP-8

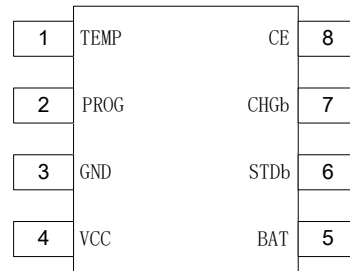

HP4056 (Top view)

## PIN DESCRIPTION:

Pin Number	Pin Name	Function
1	TEMP	Battery temperature detection and protection input pin. The higher threshold is $0.8 \cdot V_{CC}$ and lower threshold is $0.45 \cdot V_{CC}$ . If it is useless, please pull it low to ground.
2	PROG	Charge current setting, charge current monitor and shut down pin. The charging current is given by $I_{BAT} = 1000/R_{PROG}(A)$ . Please choose 1% precision resistor for $R_{PROG}$ .
3	GND	Ground
4	VCC	Power Supply
5	BAT	Charge Current Output. Provides charge current to the battery and regulates the final float voltage to 4.2V or 4.35V.
6	STDb	Charge termination indicated pin. When charge is terminated, it is pulled low, otherwise it is high impedance.
7	CHGb	Open-Drain Charge Status Output. When the battery is charging, the CHGb pin is pulled low. When the charge cycle is completed or VCC is removed, the CHGb is forced high impedance.
8	CE	Charge enable pin. High is enable, low is disable.

## ABSOLUTE MAXIMUM RATINGS (Note)

SYMBOL	ITEMS	VALUE	UNIT
$V_{CC}$	Input Voltage	-0.3~8	V
$V_{PROG}$	PROG Voltage	-0.3~ $V_{CC}+0.3$	V
$V_{BAT}$	BAT Voltage	-0.3~7	V
All other pins	Input Voltage	-0.3~10	V
$P_{D\_MAX}$	Power Dissipation	ESOP-8	1
$T_J$	Junction Temperature	-40~125	°C
$T_{STG}$	Storage Temperature	-55 to 150	°C
$T_{SOLDER}$	Package Lead Soldering Temperature	260°C, 10s	

**Note:** Exceed these limits to damage to the device. Exposure to absolute maximum rating conditions may affect device reliability.

## RECOMMENDED OPERATING CONDITION

		MIN	NOM	MAX	UNIT
V <sub>CC</sub>	Input operating voltage range	4.5	5	5.5	V
I <sub>BAT</sub>	Battery charge current range	250	500	1000	mA
T <sub>J</sub>	Junction temperature	0		125	°C
R <sub>PROG</sub>	CC mode charge current programming resistor	1	2	4	KΩ

## SIMPLIFIED BLOCK DIAGRAM

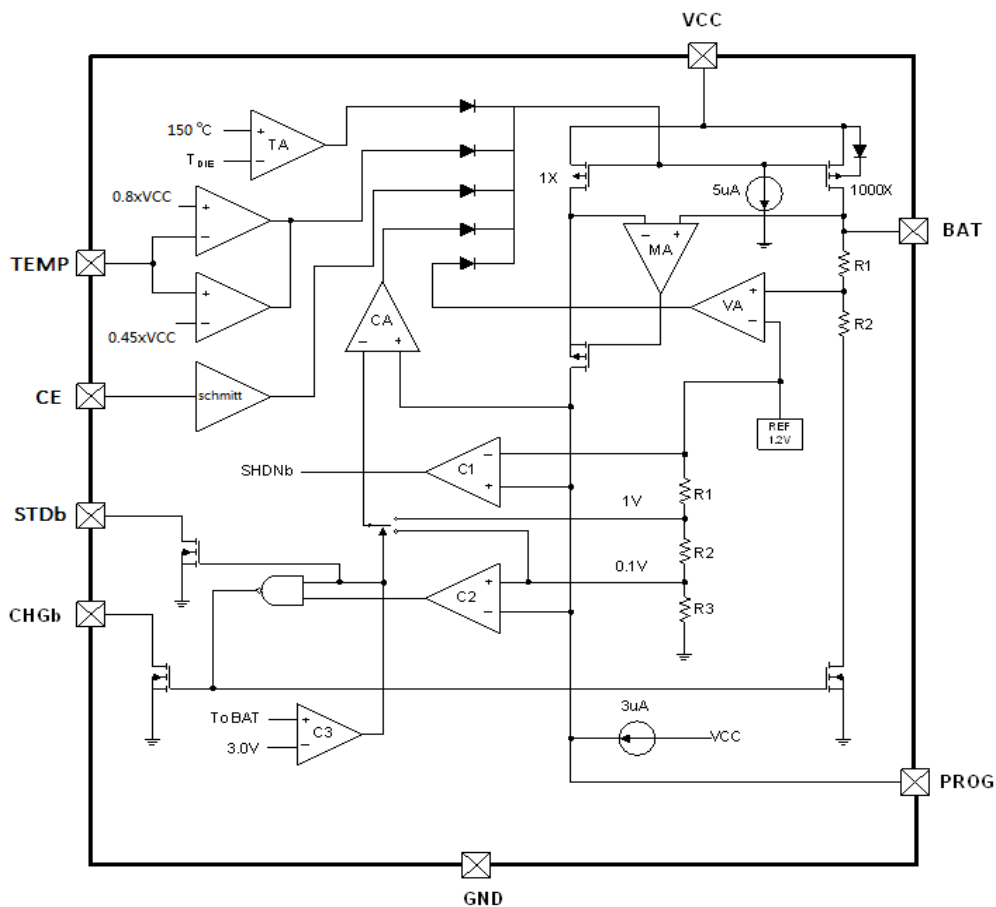

## ELECTRICAL CHARACTERISTICS

The following specifications apply for  $V_{CC}=5V$   $T_A=25^{\circ}C$ , unless specified otherwise.

SYMBOL	ITEMS	CONDITIONS	MIN	TYP	MAX	UNIT
$V_{CC}$	Supply Voltage		4	5	8	V
$I_{SPLYCHRG}$	Charge Mode GND Current	$R_{PROG}=2k\Omega$ , $V_{CC}=5V$		160		$\mu A$
$I_{BATCHRG}$	Charge Mode Battery Current	$R_{PROG}=1k\Omega$	0.9	1	1.1	A
		$R_{PROG}=2k\Omega$	450	500	550	mA
$V_{PROGCHRG}$	PROG Pin Voltage	$R_{PROG}=1k\Omega$	0.9	1	1.1	V
		$R_{PROG}=2k\Omega$	0.9	1	1.1	V
$I_{SPLYSTBY}$	Standby Mode Supply Current	Charge Terminated		130		$\mu A$
$I_{BATSTBY}$	Standby Mode Battery Current	Charge Terminated		3		$\mu A$
$I_{SPLYASD}$	Shutdown Mode Supply Current	$2V < V_{CC} < V_{BAT}$		36		$\mu A$
$I_{BATASD}$	Shutdown Mode BAT Pin Current	$2V < V_{CC} < V_{BAT}$		0.5	1	$\mu A$
$I_{BATSLEEP1}$	Sleep Mode BAT Pin Current	$V_{CC}=0V$ , $V_{BAT}=4.2V$		0.02	0.1	$\mu A$
$I_{BATSLEEP2}$	Sleep Mode BAT Pin Current	$V_{CC}$ floating, $V_{BAT}=4.2V$		0.02	0.1	$\mu A$
$I_{CHGb}$	CHGb Pin pull low current	Charge mode, $V_{CHGb}=1V$	10	30	50	mA
$V_{FLOAT}$	Float Voltage	Charge Terminated	4.158	4.2	4.242	V
			4.306	4.35	4.394	V
$I_{TRIKL}$	Trickle Charge Current	$V_{BAT} < V_{TRIKL}$ , $R_{PROG}=1k\Omega$	40	100	140	mA
$V_{TRIKL}$	Trickle Charge Voltage Threshold	$V_{BAT}$ from low to high	2.8	2.9	3.0	V
$V_{TRIKL, HYS}$	Trickle Charge Voltage Hysteresis	$V_{BAT}$ from high to low		200		mV
$V_{UVLO}$	UVLO Threshold	$V_{CC}$ from low to high	3.5	3.7	3.9	V
$V_{UVLO, HYS}$	UVLO Hysteresis	$V_{CC}$ from high to low		260		mV
$V_{ASD}$	$V_{CC}-V_{BAT}$ Lockout Threshold Voltage	$V_{CC}$ from high to low		70		mV
		$V_{CC}$ from low to high		300		mV
$\Delta V_{RECHRG}$	Auto Recharge Battery Voltage	$V_{FLOAT} - V_{RECHRG}$	100	150	200	mV
$V_{CHGb}$	CHGb Pin Output Low Voltage	$I_{CHGb}=10mA$		0.2	0.4	V
$V_{STDb}$	STDb Pin Output Low Voltage	$I_{STDb}=5mA$		0.3	0.6	V
$V_{TEMP-H}$	TEMP Pin High Turn Over Voltage			80	82	%Vin
$V_{TEMP-L}$	TEMP Pin Low Turn Over Voltage		43	45		%Vin
$V_{CE-L}$	CE Pin Input Low Voltage				0.4	V
$V_{CE-H}$	CE Pin Input High Voltage		1.2			V
$R_{ON}$	Power FET ON Resistance	$R_{PROG}=2k\Omega$ , $V_{CC}=4.2V$		0.37		$\Omega$
$T_{SS}$	Soft-Start Time			100		us
$T_{RECHRG}$	Recharge Comparator Filter Time			2		ms
$T_{TERM}$	Charge Terminated Filter Time			1		ms

## TYPICAL CHARACTERISTICS

$V_{PROG}$  vs. Input Voltage

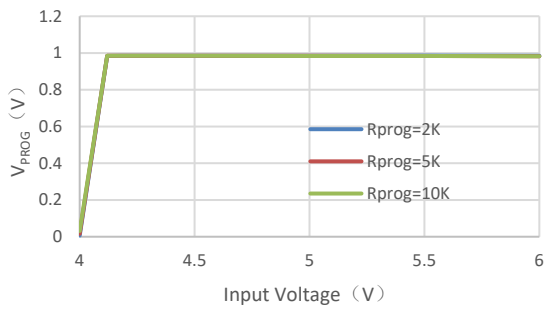

$V_{PROG}$  vs. Temperature

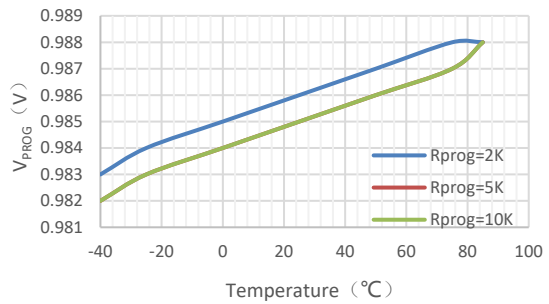

Charge Current vs. Input Voltage

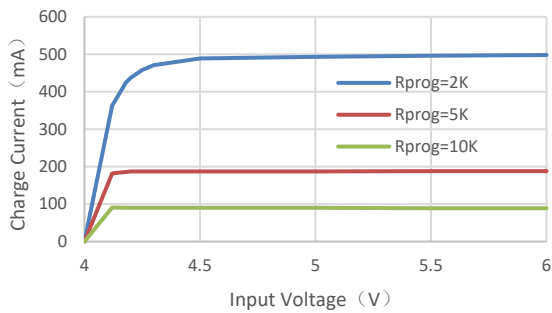

Charge Current vs.  $V_{PROG}$

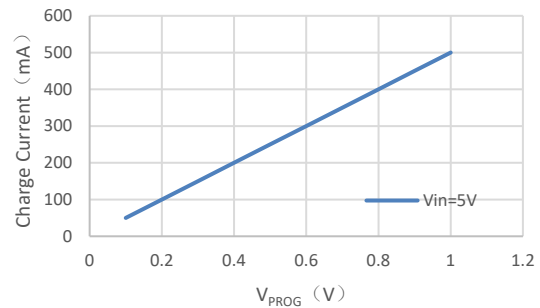

Charge Current vs. Battery Voltage

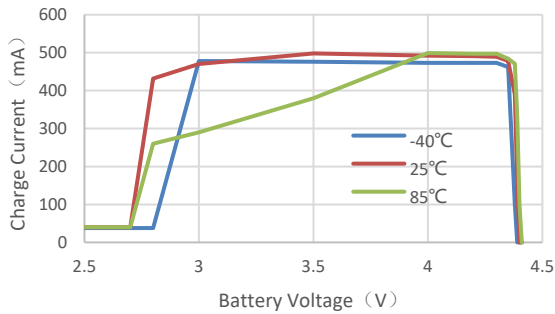

Charge Current vs. Temperature

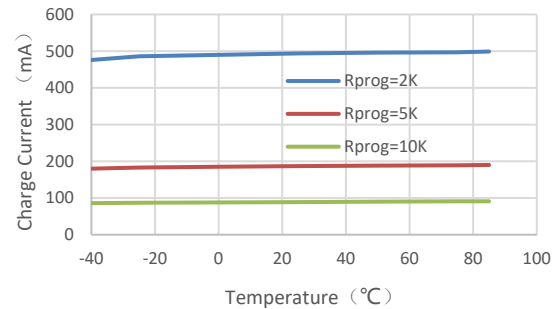

Trickle Current vs. Input Voltage

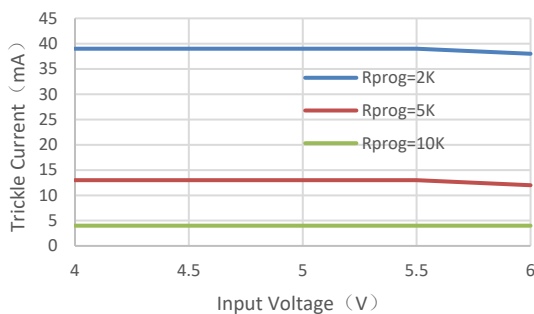

Trickle Current vs. Temperature

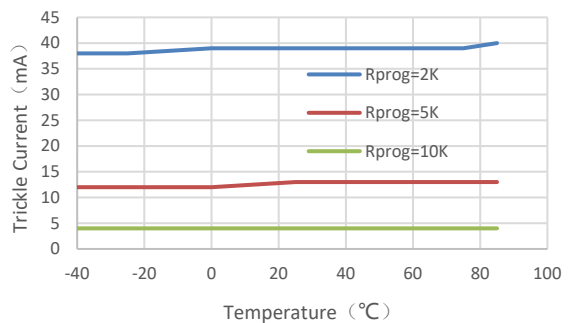

Trickle Voltage vs. Temperature

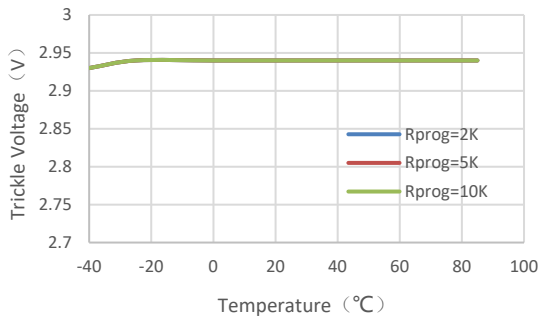

Trickle Voltage vs. Input Voltage

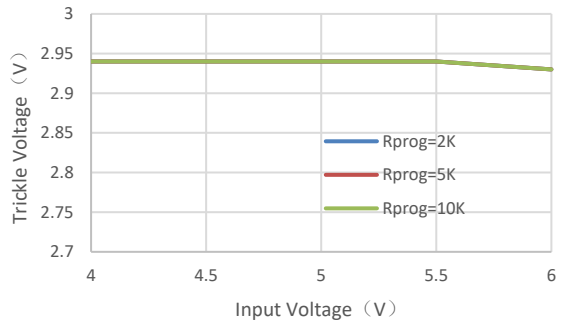

Float Voltage vs. Input Voltage

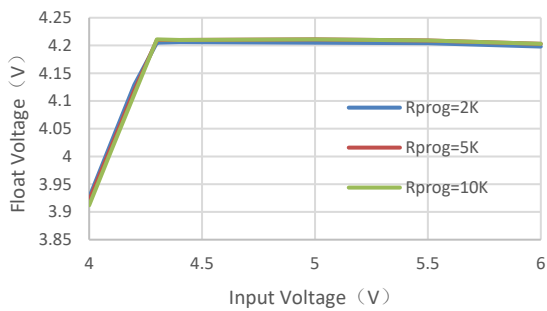

Float Voltage vs. Temperature

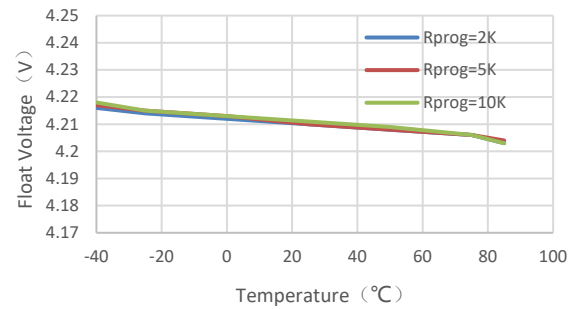

Vrecharge vs. Temperature

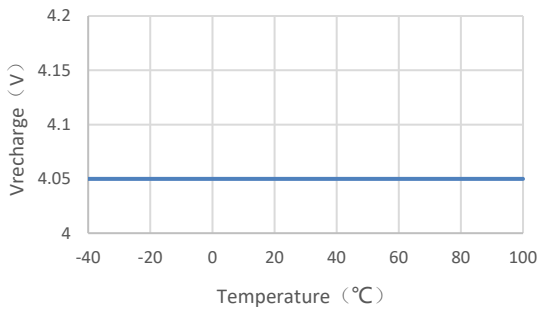

CHGb Current vs. CHGb Voltage

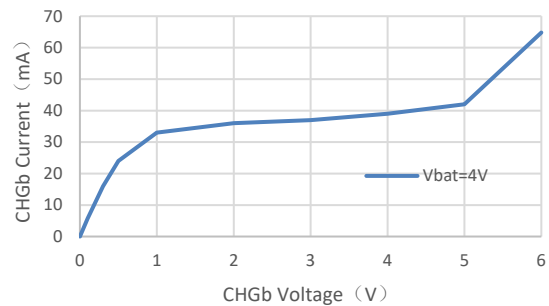

Ron vs. Temperature

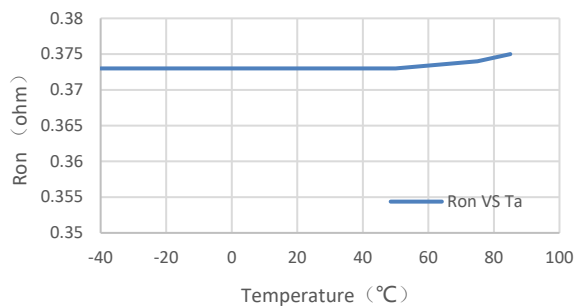

Charging Curve

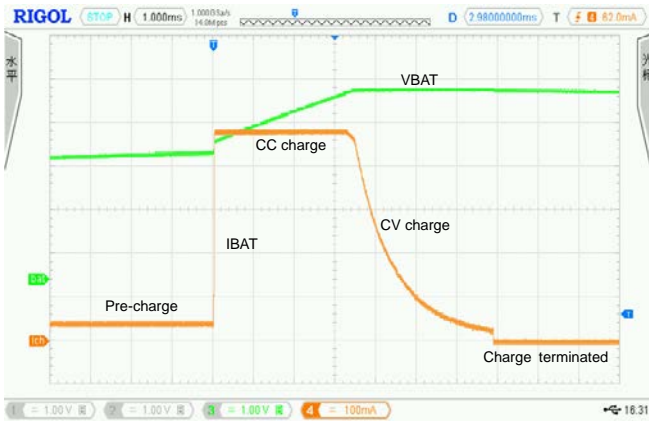

## OPERATION INFORMATION

The HP4056 is a single battery Li-Ion battery charger using a constant-current / constant-voltage algorithm. It can deliver up to 1A of charge current (using a good thermal PCB layout) with a final float voltage accuracy of  $\pm 1\%$ . The HP4056 includes an internal P-channel power MOSFET and thermal regulation circuitry. No blocking diode or external current sense resistor is required, thus the basic charger circuit requires only two external components. Furthermore, the HP4056 is capable of operating from a USB power source.

### Normal charge cycle

A charge cycle begins when the voltage at the VCC pin rises above the UVLO threshold level and a 1% program resistor is connected from the PROG pin to ground or when a battery is connected to the charger output. If the BAT pin is less than 3.0V, the charger enters trickle charge mode. In this mode, the HP4056 supplies approximately 1/10 the programmed charge current to bring the battery voltage up to a safe level for full current charging.

When the BAT pin voltage rises above 3.0V, the charger enters constant-current mode, where the programmed charge current is supplied to the battery. When the BAT pin approaches the final float voltage, the HP4056 enters constant-voltage mode and the charge current begins to decrease. The charge cycle ends when the PROG voltage is less than 100mV.

### Programming charge current

The charge current is programmed using a single resistor from the PROG pin to ground. The battery charge current of constant current mode is 1000 times the current out of the PROG pin. The program resistor and the charge current of constant current are calculated using the following equations:

$$I_{\text{CHG}} = 1000 / R_{\text{PROG}} \text{ (A)}$$

Please choose 1% precision resistor for RPROG, this will effect the accuracy of CC charge current and termination current.

### Charge termination

A charge cycle is terminated when the charge current falls to 1/10 of the programmed value after the final float voltage is reached. This condition is detected by using an internal, filtered comparator to monitor the PROG pin. When the PROG pin voltage falls below 100mV for longer than  $T_{\text{TERM}}$  (typically 1ms), charging is terminated. The charge current is latched off and the HP4056 enters standby mode, where the input supply current drops to 130uA. (Note: 1/10 CC termination is disabled in trickle charging mode and thermal limiting modes).

When charging, transient loads on the BAT pin can cause the PROG pin to fall below 100mV for short periods of time before the DC charge current has dropped to 1/10 of the programmed value. The 1ms filter time ( $T_{\text{TERM}}$ ) on the termination comparator ensures that transient loads of this nature do not result in premature charge cycle termination. Once the average charge current drops below 1/10 of the programmed value, the HP4056 terminates the charge cycle and ceases to provide any current through the BAT pin, the chip will be put into standby mode. In this state, all loads on the BAT pin must be supplied by the battery.

The HP4056 constantly monitors the BAT pin voltage in standby mode. If this voltage drops below the 4.05V/4.15V recharge threshold ( $V_{\text{RECHRG}}$ ), another charge cycle begins and current is once again supplied to the battery. The state diagram of a typical charge cycle is as below:



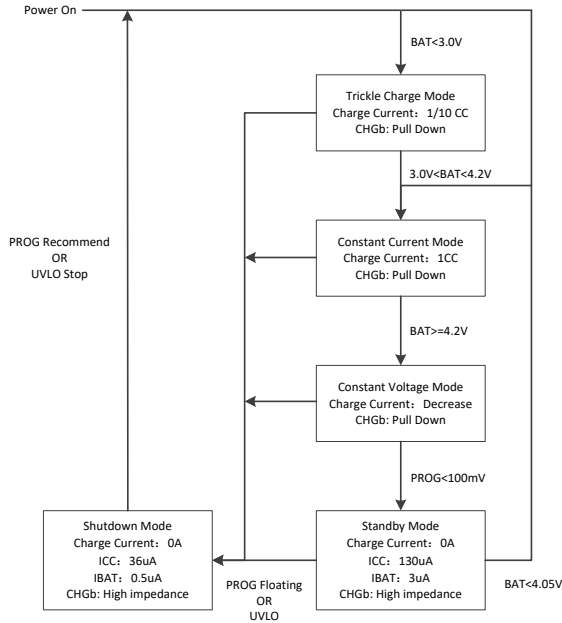

### Charge status indicator (CHGb)

The charge status output indicator is an open drain circuit. The indicator has two different states: pull-down (~30mA), and high impedance. The pull-down state indicates that the HP4056 is in a charge cycle. High impedance indicates that the charge cycle is complete. The CHGb also can be used to detect the charge states by a microprocessor with a pull-up resistor.

### Shutdown mode

At any point in the charge cycle, the HP4056 can be put into shutdown mode by removing PROG thus floating the PROG pin. This reduces the battery drain current to less than 0.5uA and the supply current to

less than 36uA. A new charge cycle can be initiated by reconnecting the program resistor. Below is a recommend application.

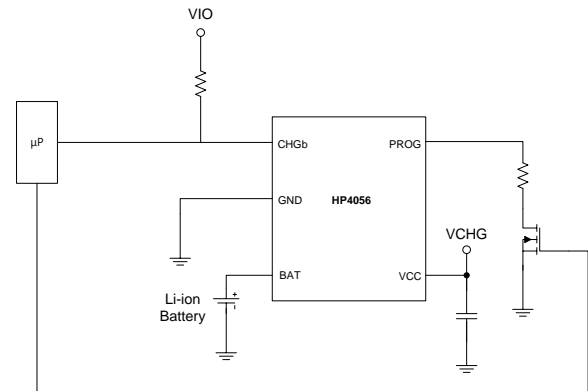

The HP4056 also be put into shutdown mode when VCC voltage down to UVLO threshold. In this state, the CHGb pin is high impedance state. The CHGb pin is also in a high impedance state if the charge cycle is completed.

### Automatic recharge

Once the charge cycle is terminated, the HP4056 continuously monitors the voltage on the BAT pin using a comparator with a 2ms filter time ( $T_{RECHRG}$ ). A charge cycle restarts when the battery voltage falls below 4.05V/4.15V (which corresponds to approximately 80% to 90% battery capacity). This ensures that the battery is kept at or near a fully charged condition and eliminates the need for periodic charge cycle initiations. CHGb output enters a pull-down state during recharge cycles.

## APPLICATION INFORMATIONS

### Stability considerations

The constant-voltage mode feedback loop is stable without an output capacitor provided a battery is connected to the charge output. With no battery present, an output capacitor is recommended to reduce ripple voltage. When using high value, low ESR ceramic capacitors, it is recommended to add a 1Ω resistor in series with the capacitor. No series resistor is needed if tantalum capacitors are used.

In constant-current mode, the PROG pin is in the feedback loop, not the battery. The constant-current mode stability is affected by the impedance at the PROG pin. With no additional capacitance on the PROG pin, the charger is stable with program resistor values as high as 50KΩ. However, additional capacitance on this node reduces the maximum allowed program resistor thus it should be avoided.

### Thermal limit

An internal thermal feedback loop reduces the programmed charge current if the die temperature attempts to rise above a preset value of approximately 150 °C . This feature protects the HP4056 from excessive temperature and allows the user to push the limits of the power handling capability of a given circuit board without risk of damaging the HP4056. The charge current can be set according to typical (not worst-case) ambient temperature with the assurance that the charger will automatically reduce the current in worse-case conditions.

### Power dissipation

The conditions that cause the HP4056 to reduce charge current through thermal feed-back can be approximated by considering the power dissipated in the IC. Nearly all of this power dissipation is generated by the internal MOSFET. This is calculated to be approximately:

$$P_D = (V_{CC} - V_{BAT}) * I_{BAT}$$

It is important to remember that HP4056 applications do not be designed for worst-case thermal conditions since the IC will automatically reduce power dissipation when the junction temperature reaches approximately 160°C (Constant temperature mode).

### VCC bypass capacitor

Many types of capacitors can be used for input bypass, however, caution must be exercised when using multilayer ceramic capacitors. Because of the self-resonant and high Q characteristics of some types of ceramic capacitors, a 10uF/16V ceramic capacitor is recommended for this bypass capacitor. Due to a high voltage transient will be generated under some start-up conditions, such as connecting the charger input to a live power source.

### Charge current soft-start

The HP4056 includes a soft-start circuit to minimize the inrush current at the start of a charge cycle. When a charge cycle is initiated, the charge current ramps from zero to the full-scale current over a period of approximately 100us. This has the effect of minimizing the transient current load on the power supply during start-up.

### PACKAGE OUTLINE

Package	ESOP-8	Devices per reel	2500Pcs	Unit	mm
---------	--------	------------------	---------	------	----

Package Dimension:

NOTES:  
ALL DIMENSIONS REFER TO JEDEC STANDARD MS-012 AA  
DO NOT INCLUDE MOLD FLASH OR PROTRUSIONS.

Symbol	Millimeter			Symbol	Millimeter		
	MIN	NOM	MAX		MIN	NOM	MAX
A	-	-	1.77	D	4.7	4.9	5.1
A1	0.08	0.18	0.28	E	5.8	6	6.2
A2	1.2	1.4	1.6	E1	3.7	3.9	4.1
A3	0.55	0.65	0.75	e	1.27BSC		
b	0.37	0.4	0.44	L	0.5	0.65	0.8
b1	0.36	0.39	0.43	L1	1.05BSC		
c	0.21	-	0.26	$\theta$	0	-	8°
D1	3.1	3.3	3.5	E2	2.2	2.4	2.6

## Revision History

Version No.	Date	Description
Preliminary	2017-07-05	-Initial Preliminary release
Version 0.1	2019-08-08	-Update package/marketing information -Update part number
Version 0.2	2020-04-23	-Update ordering information

## X-ON Electronics

Largest Supplier of Electrical and Electronic Components

*Click to view similar products for [Battery Management](#) category:*

*Click to view products by [Hypower Microelectronics](#) manufacturer:*

Other Similar products are found below :

[MP2602DQ-LF-P](#) [MP26053DQ-LF-Z](#) [MP2611GL-P](#) [NCP347MTAHTBG](#) [LM3658SD-AEV/NOPB](#) [MP2607DL-LF-P](#) [MP26121DQ-LF-P](#)  
[MP26123DR-LF-P](#) [MP2633GR-P](#) [MP2637GR-P](#) [BQ24212EVM-678](#) [NCP1855FCCT1G](#) [MP2636GR-P](#) [FAN54063UCX](#)  
[MAX14680EWC+T](#) [MAX14634EWC+T](#) [DS2745U+T&R](#) [MAX14578EETE+T](#) [DS2781EVKIT+](#) [DS2781E+T&R](#) [MP2605DQ-LF-P](#)  
[DS2710G+T&R](#) [MAX17040G+T](#) [MAX14525ETA+T](#) [MP2615GQ-P](#) [MAX14578EEWC+T](#) [LC05132C01NMTTGTG](#) [MAX8971EWP+T](#)  
[MAX14630EZK+T](#) [MAX1873TEEE+T](#) [PSC5415A](#) [AUR9811DGD](#) [SN2040DSQR](#) [DS2715BZ+T&R](#) [MAX1508ZETA+T](#)  
[MAX14921ECS+T](#) [MAX77301EWA+T](#) [BD8668GW-E2](#) [MAX16024PTBS+T](#) [DS2715Z+T&R](#) [MAX16024LTBZ18+T](#) [DS2782E+T&R](#)  
[DS2782G+T&R](#) [MAX1908ETI+T](#) [ISL95522IRZ](#) [ISL95522HRZ](#) [ARD00558](#) [NCP4371AAEDR2G](#) [BD8665GW-E2](#) [MAX8934EETI+T](#)