

JTAG

series

SIGNUM SYSTEMS CORPORATION

JTAG Probes for Signum Emulators

Technical Specifications

SIGNUM
SYSTEMS

COPYRIGHT NOTICE

Copyright (c) 2016 by Signum Systems Corporation, an IAR Systems company. All rights are reserved worldwide. No part of this publication may be reproduced, transmitted, transcribed, stored in a retrieval system, or translated into any language or computer language, in any form or by any means, electronic, mechanical, magnetic, optical, chemical, manual, or otherwise, without the prior written permission of Signum Systems.

DISCLAIMER

Signum Systems makes no representations or warranties with respect to the contents hereof and specifically disclaims any implied warranties of merchantability or fitness for any particular purpose. Also, Signum Systems reserves the right to revise this publication and to make changes from time to time in the content hereof without obligation of Signum Systems to notify any person or organization of such revision or changes.

WARRANTY

Signum Systems warrants to the original purchaser that this product is free of defects in material and workmanship and performs to applicable published Signum Systems specifications for a period of TWELVE MONTHS from the date of shipment. If defective, the product must be returned to Signum Systems, prepaid, within the warranty period, and it will be repaired or replaced (at our option) at no charge. Equipment or parts which have been subject to misuse, abuse, alteration, neglect, accident, unauthorized installation or repair are not covered by warranty. This warranty is in lieu of any other warranty expressed or implied. **IN NO EVENT SHALL SIGNUM SYSTEMS BE LIABLE FOR CONSEQUENTIAL DAMAGES OF ANY KIND.** It is up to the purchaser to determine the reliability and suitability of this product for his particular application.

SIGNUM
S Y S T E M S

IAR
SYSTEMS

1211 FLYNN RD., UNIT #104
CAMARILLO, CA 93012, U.S.A.
PHONE 805 • 383 • 3682
WWW.SIGNUM.COM

Signum JTAG Probes at a Glance

PART NUMBER	DESCRIPTION	VOLTAGE	PINOUT	CPU	PG
ADA-JET-ARM20	Standard 20-pin ARM JTAG probe.	3.3 – 5.0V (± 10%)	ARM20	ARM/XScale Cortex-A/R/M	2
ADA-JET-ARM14	Standard 20-pin ARM JTAG probe with 14-pin passive extender.	3.3 – 5.0V (± 10%)	ARM20 ARM14	ARM/XScale Cortex-A/R/M	2
ADA-JET-ARM20-LV	Low voltage version of ADA-JET-ARM20.	1.8 – 3.3V (± 10%)	ARM20	ARM/XScale Cortex-A/R/M	3
ADA-JET-ARM-SWD	Low-voltage probe with Cortex-M SWD and SWO capabilities.	0.8 – 5.0V (± 10%)	ARM20 Cortex20 Cortex10	ARM/XScale Cortex-A/R/M	5
ADA-ARM20-Cortex	Conversion adapter from ADA-JET-ARM20 and ADA-JET-ARM20-LV probe to Cortex 20-pin and Cortex 10-pin connectors.	N/A (passive)	Cortex20 Cortex10	Cortex-M	7
ADA-JET-TI14	Standard 14-pin JTAG probe for Texas Instruments DSP and ARM-based processors.	3.3 – 5.0V (± 10%)	TI14	Texas Instruments*	8
ADA-JET-TI14-LV	Low voltage version of ADA-JET-TI14.	1.8 – 3.3V (± 10%)	TI14	Texas Instruments*	8
ADA-ISO-TI14	JTAG isolation probe for Texas Instruments DSP and ARM-based processors.	3.0 – 5.0V (± 10%)	TI14	Texas Instruments**	9
ADA-ISO-TI14-E	JTAG isolation probe for Texas Instruments DSP and ARM-based processors with optional External Power Input.	3.3 – 5.0V (± 10%)	TI14	Texas Instruments**	11
ADA-JET-CTI20	Low-voltage compact 20-pin JTAG probe for Texas Instruments DSP and ARM-based processors.	1.8 – 3.3V (± 10%)	cTI20	Texas Instruments*	12
ADA-ETM-JTAG	Conversion ETM to JTAG adapter. Allows JTAGjet-Trace emulators to be used with boards without ETM connector.	N/A (passive)	ETM38 ARM20 TI14	Any	15
ADA-ETM-SWD20	Conversion adapter to Cortex 20-pin connector. To be used with JTAGjet-Trace emulators.	N/A (passive)	Cortex20	Cortex-M	16
ADA-JET-MPSD	12-pin TI MPSD (legacy) probe.	5.0 V (± 10%)	MPSD	TMS320C30/ C31/C32	17

TABLE 1 Comparison of selected Signum JTAG probes.

* Any Texas Instruments TMS320 DSP and ARM-based CPU including C2000, C5000, C6000, TMS470, TMS570, OMAP, DaVinci and Sitara. Consult your CPU/board documentation and for JTAG connector and voltage requirements. Some boards with Texas Instruments CPUs may also have standard ARM 20-pin connector.

** Isolation probe can be used with any Texas Instruments device, but it is limited to 15MHz JTAG clock.

PROBE	PINOUT	PROBE	PINOUT
ARM20	Figure 2 on page 2	TI14	Figure 18 on page 8
ARM14	Figure 4 on page 2	cTI20	Figure 30 on page 12
Cortex20	Figure 13 on page 5	ETM38	Figure 35 on page 14
Cortex10	Figure 14 on page 5	MPSD	Figure 44 on page 17

TABLE 2 Signum probe pinouts.

JTAG Probes for ARM

ADA-JET-ARM20 and ADA-JET-ARM14

Signum JTAG probes for ARM provide a physical interface between Signum emulators for the ARM processor and ARM target boards. These probes have 20-pin (ADA-JET-ARM20) and 14-pin (ADA-JET-ARM14) double-row, polarized, .100" × .100". (2.54 mm × 2.54 mm) female connectors. Signum JTAG probes come with a 30.5 cm (12 in.) cable. The layout and dimensions of the probes are shown in **Figure 1** through **Figure 10**.

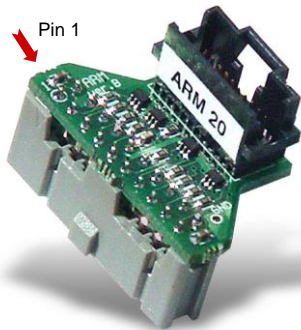

FIGURE 1 The 20-pin JTAG ADA-JET-ARM20 probe for ARM.

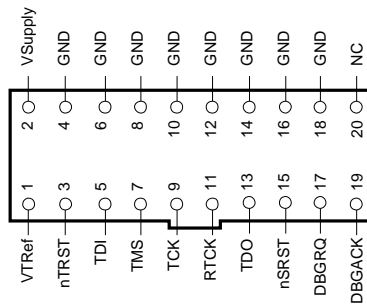

FIGURE 2 The pinout of the ADA-JET-ARM20 probe. Top view.

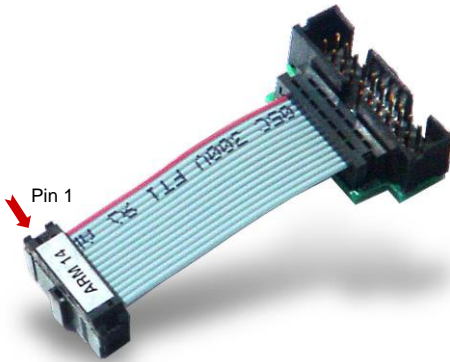

FIGURE 3 The 14-pin JTAG ADA-JET-ARM14 probe for ARM.

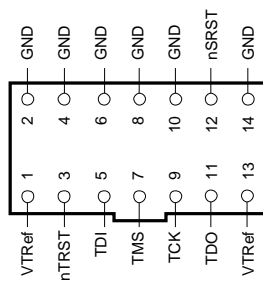

FIGURE 4 The pinout of the 14-pin JTAG probe for ARM. Top view.

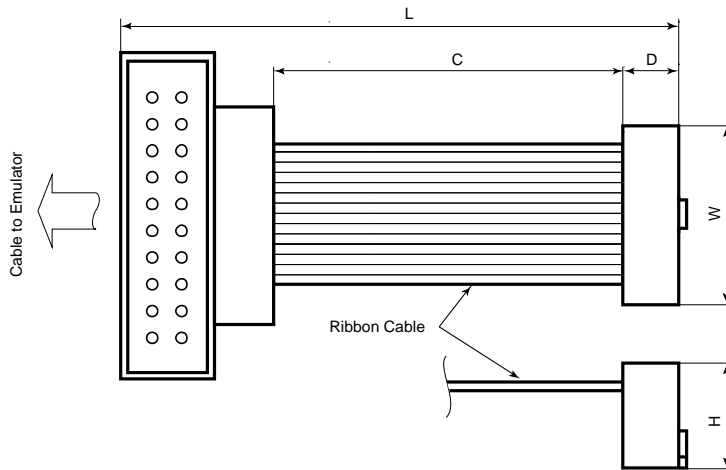

FIGURE 5 The dimensions of the ADA-JET-ARM14 probe with a cable extender. L = 63.0 mm (2.5 in.), C = 40.0 mm (1.55 in.) D = 6.0 mm (.24 in.), W = 22.5 mm (.9 in.), H = 11.5 mm (0.45 in.).

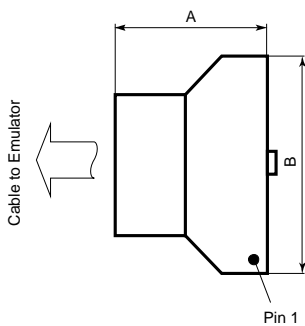

FIGURE 6 The dimensions of the ADA-JET-ARM20 probe. Top view. A = 19.3 mm (0.76 in.) [low-voltage: A = 24.3 mm (0.96 in.)] B = 30.5 mm (1.2 in.)

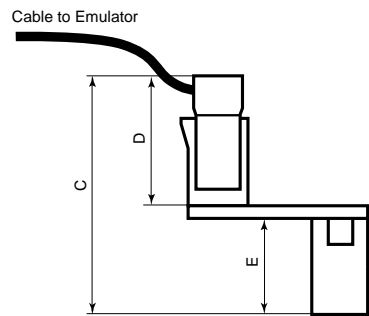

FIGURE 7 The dimensions of the ADA-JET-ARM20 probe. Side view. C = 22.7 mm (0.88 in.) D = 15.0 mm (0.59 in.) E = 11.0 mm (0.43 in.)

ADA-JET-ARM20-LV

Your emulator can also be ordered with a low-voltage variant of the JTAG probe (Figure 8), or with both standard and low-voltage variants. These two variants have identical pinouts, but slightly differ in dimensions (cf. the caption of Figure 6). The voltage range of the low-voltage probe is 1.8V – 3.3V ($\pm 10\%$).

Caution: Voltages higher than 3.3V may permanently damage the low-voltage probe.

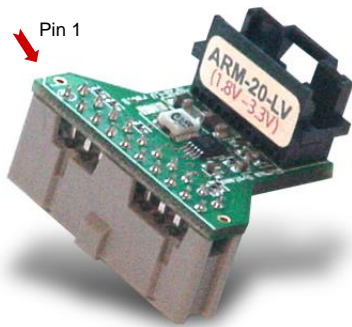

FIGURE 8 The 20-pin JTAG ADA-JET-ARM20-LV probe for ARM.

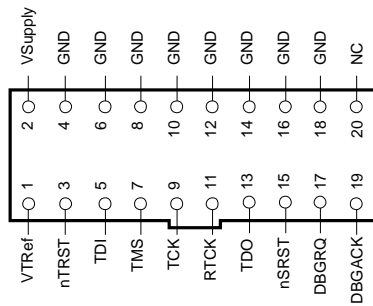

FIGURE 9 The pinout of the ADA-JET-ARM20-LV probe. Top view.

Cable Extender

In addition to its standard version shown on page 3, the 20-pin probe is offered in a version with a 1.55 in. ribbon cable extender that allows the probe to remain outside the target board by lowering the probe’s profile. (The 14-pin probe comes always with a ribbon cable extender.)

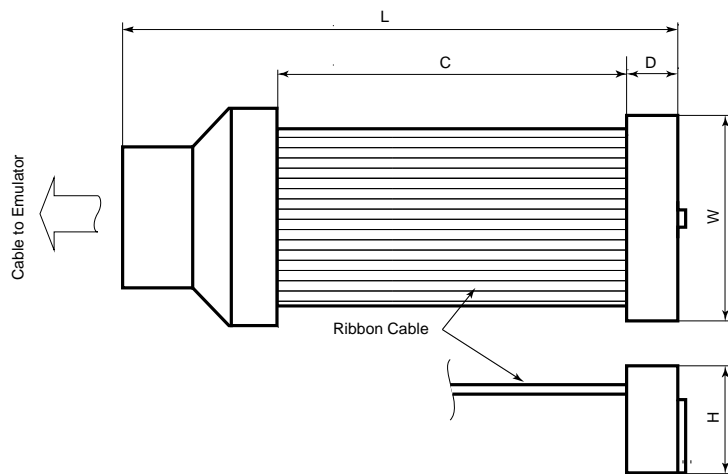

FIGURE 10 Top and side views of the 20-pin ARM probe with a cable extender. L = 69 mm (2.7 in.), C = 40.0 mm (1.55 in) D = 6.0 mm (.24), W = 30.0 mm (1.2 in.), H = 11.5 mm (0.45 in.).

Target Board Header

On the target board, we recommend using a polarized box header, such as:

14 - P I N	20 - P I N
14-Pin, Double-Row, Polarized Box Header-Straight, .100" × .100" (2.54 mm × 2.54 mm). Manufacturers:	20-Pin, Double-Row, Polarized Box Header-Straight, .100" × .100" (2.54 mm × 2.54 mm). Manufacturers:
<ul style="list-style-type: none"> 3M (Mouser Electronics, Part No. 517—2514-6002). tyco/AMP, Part No. 103308-2 – Digi-Key Part No A26269-ND. 	<ul style="list-style-type: none"> 3M (Mouser Electronics, Part No. 517—2520-6002). tyco/AMP, Part No. 103308-5 – Digi-Key Part No. A26273-ND.

TABLE 3 Recommended target board headers.

ADA-ARM-SWD

The ARM-SWD probe supports both ARM and Cortex boards at voltages 0.8V to 5.0V. It must be used when Cortex Serial Wire Debug or Cortex Serial Wire Output operation mode is required.

In addition to a standard 20-pin double-row female ARM connector, this probe has a 20-pin and 10-pin high-density Cortex connectors. Only one connector can be used at a time. The ARM connector, mounted underneath the probe, has the pinout of the ADA-JET-ARM20 probe (Figure 12). The pinouts of the 20-pin and 10-pin Cortex connectors are shown in Figure 13 and Figure 14, respectively. The two high-density cables included with the probe provide a link between the Cortex connectors and the target board (Figure 11).

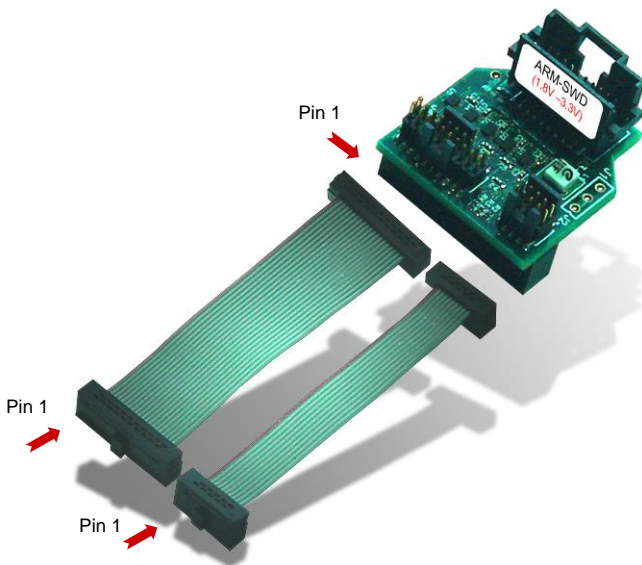

Figure 11 The ADA-ARM-SWD probe with the Cortex cables.

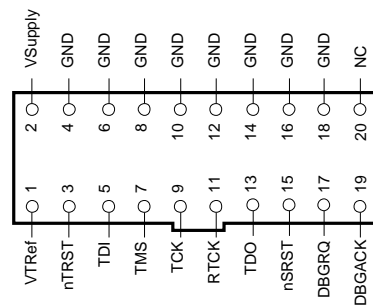

Figure 12 The ARM20 pinout of the ADA-ARM-SWD probe's ARM connector. Top view.

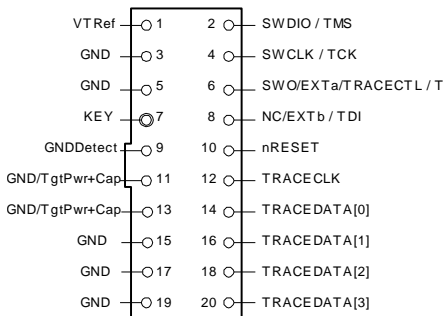

FIGURE 13 The Cortex20 pinout of the ADA-ARM-SWD probe's high-density 20-pin Cortex connector. Top view.

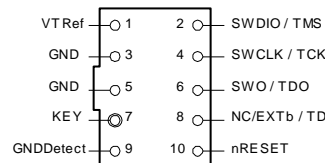

FIGURE 14 The Cortex10 pinout of the ADA-ARM-SWD probe's high-density 10-pin Cortex connector. Top view.

The mating JTAG headers for targets are shrouded with a key, but will require removal of one pin (Table 4).

S A M T E C P A R T N O .	D E S C R I P T I O N
FTSH-110-01-L-DV-K	20-pin Cortex header (0.05 x 0.05 in. spacing)
FTSH-105-01-L-DV-K	10-pin Cortex header (0.05 x 0.05 in. spacing)

TABLE 4 ARM Cortex probe-mating headers by Samtec Inc.

ARM Cortex Probe

ADA-ARM20-Cortex

This passive adapter allows you to interface any Signum JTAGjet emulator that uses the 20-pin JTAG probe for ARM (ADA-JET-ARM20 or its low-voltage variant ADA-JET-ARM20-LV) with a Cortex-M target board. Both 20-pin and 10-pin high-density Cortex connectors are supported, but only one of them can be used at a time. The ARM connector of the probe has the pinout of the ADA-JET-ARM20 probe (Figure 2). The pinouts of the 20-pin and 10-pin Cortex connectors are shown in Figure 13 and Figure 14 (page 5), respectively.

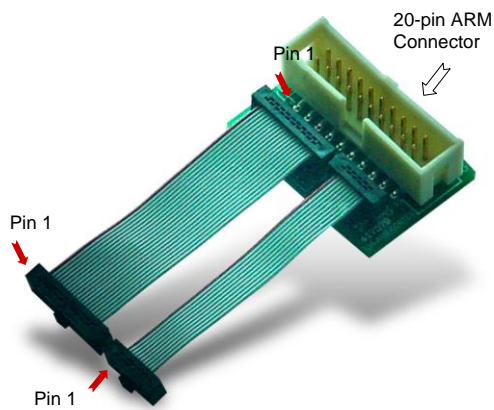

FIGURE 15 The ADA-ARM20-SWD probe for the JTAGjet.

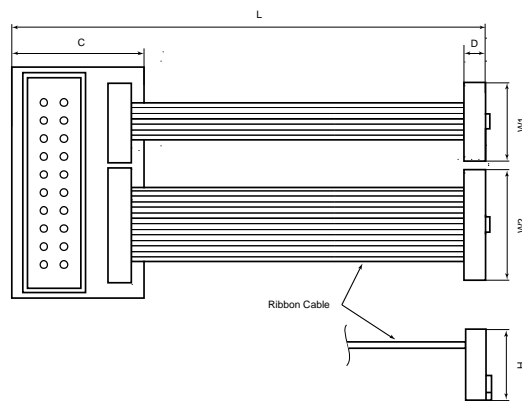

FIGURE 16 The dimensions of the ADA-ARM20-SWD probe. C = 23.6 mm (0.93 in), D = 3.11 mm (0.122 in), H = 5.1 mm (0.2 in), L = 69.3 mm (2.73 in), W = 15.73 (0.62 in), W1 = 10.5 mm (0.41 in), W2 = 16.9 mm (0.67).

The mating JTAG headers for targets are the same as those for the ADA-ARM-SWD probe (Table 4 on page 6).

JTAG Probes for OMAP and TMS320 DSP

ADA-JET-TI14

The Signum JTAG probe for OMAP devices, ADA-JET-TI14, provides a physical interface between Signum emulators for the OMAP processor and OMAP target boards. This probe is the same as that for the Texas Instruments TMS320 devices. It has 14-pin double-row, polarized, .100" × .100". (2.54 mm × 2.54 mm) female connectors. The pinout and dimensions of the probe are shown below (Figure 18 through Figure 20).

Caution: Voltages higher than 4.0V may permanently damage the low-voltage probe.

ADA-JET-TI14-LV

Your emulator can also be ordered with a low-voltage, or—if so desired—with both standard and low-voltage—variants of the probe for OMAP devices. These two variants have slightly different dimensions (Figure 19). The voltage range of the low-voltage probe is 1.8 – 3.3V (± 10%).

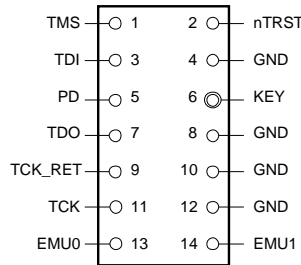

FIGURE 17 The 14-pin JTAGjet probe for OMAP and TMS320 DSP.

FIGURE 18 The TI14 pinout of the 14-pin JTAGjet probe for OMAP and TMS320 DSP.

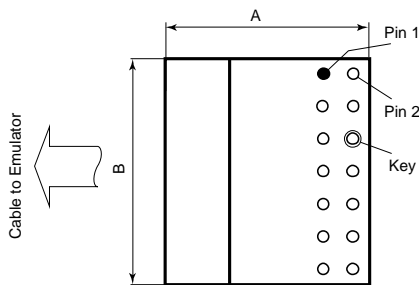

FIGURE 19 The dimensions of the 14-pin JTAGjet probe for OMAP and TMS320 DSP. Top view. A = 18.5 mm (0.73 in.) [low-voltage: 23.0 mm (0.9 in.)], B = 18.3 mm (0.72 in.).

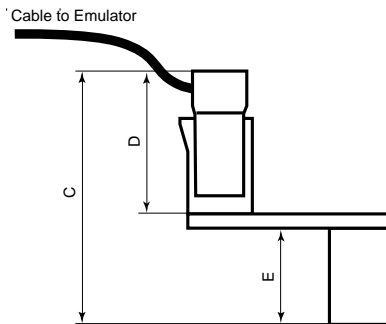

FIGURE 20 The dimensions of the 14-pin JTAGjet probe for OMAP and TMS320 DSP. Side view. C = 24 mm (.95 in.), D = 14.7 mm (0.58 in.), E = 8.5 mm (0.34 in.).

JTAG TMS320 Isolation Probe

ADA-ISO-TI14

The JTAG Isolation Probe for TMS320/470/570 Devices from Texas Instruments is a full isolation JTAG probe for JTAGjet emulators which reduces the chance of damage to the emulator associated with ground loops, voltage spikes, electrostatic discharge (ESD) and noise on power and ground lines generated by high-current motors and other machinery.

The probe fits between the JTAGjet emulator and the user's target board equipped with the Texas Instruments style 14-pin JTAG connector. The distinctive features of the ADA-ISO-TI14 include

- Support for all TMS320C2000, C5000, C6000, OMAP, DM and TMS470 / 570 devices
- Operating JTAG voltage from 3.0 V to 5.0 V ($\pm 10\%$)
- Galvanic isolation up to 1000 V (peak)*
- 50kV/ μ s transient immunity (typical) on JTAG lines
- ESD protection of 8kV on contact and 15kV air discharge
- Maximum JTAG clock rate up to 15MHz

* **Important Notice** The continuous normal operating voltage across the isolation barrier can be 0 – 60VDC. The isolation voltage only represents a measure of immunity to transient voltages—the probe should never be used as an element of a safety isolation system. This probe can be expected to function correctly with a few hundred volts offset applied continuously across the isolation barrier. However, the circuitry on both sides of the barrier is then regarded as operating at an unsafe voltage and additional isolation/insulation systems must be used in accordance with safety standard requirements.

Signum Systems shall not be liable for any damages related to the use of this probe.

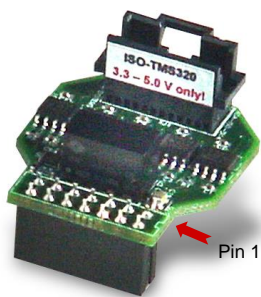

FIGURE 21 The JTAGjet TMS320 ADA-ISO-TI14 isolation probe.

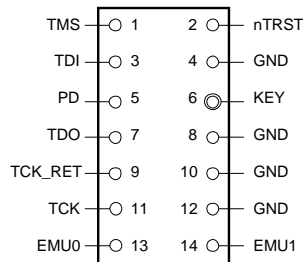

FIGURE 22 The TI14 pinout of the 14-pin JTAGjet TMS320 isolation probe.

SIGNUM SYSTEMS

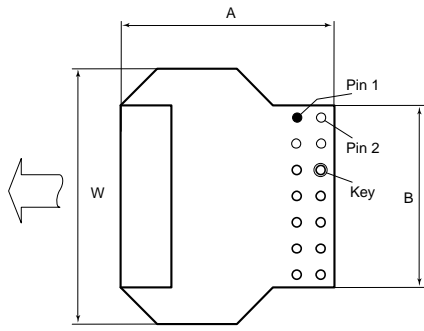

FIGURE 23 The dimensions of the 14-pin JTAGjet isolation probe for TMS320 style devices. Top view. A = 32.0 mm (1.28 in), B = 20.8 mm (0.82 in), W = 29.0 mm (1.14 in).

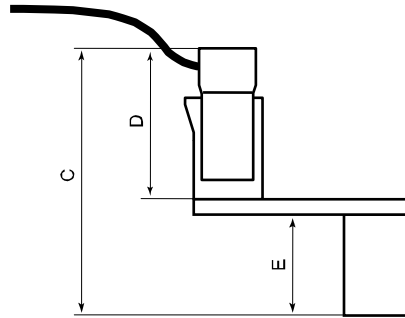

FIGURE 24 The dimensions of the 14-pin JTAGjet isolation probe for TMS320 style devices. Side view. C = 20.5 mm (.81 in), D = 14.2 mm (0.56 in), E = 8.5 mm (0.33 in).

Isolation Probe for TI-14 JTAG with an Optional External Power Input

ADA-ISO-TI14-E

The isolation probe for TI-14 JTAG with an auxiliary power input ADA-ISO-TI14-E should be used in applications where the target board does not have enough current (about 150mA) to supply the isolation probe. When used with external power adapter, this probe reduces the current taken from the target board to approximately 1 mA.

The ADA-ISO-TI14-E probe requires a 5.0V VDC external power source to be connected to the J1 socket. The polarity for the J1 socket is center pin positive (+), outer collar negative (-). Reversed polarity may damage some electronic devices. If the external power supply is not connected, the isolation probe will automatically take power (about 150mA) from the target board. The auxiliary power adapter is not included with the isolation probe.

See also the specification of the ADA-ISO.

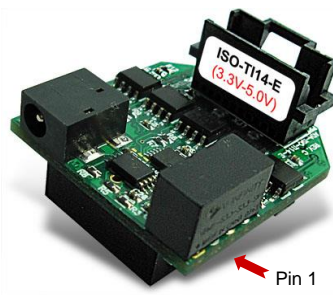

FIGURE 25 The ADA-ISO-TI14-E isolation probe with an auxiliary power input.

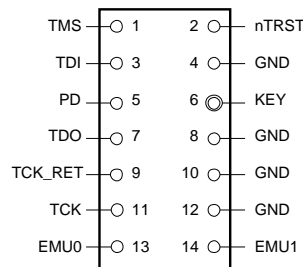

FIGURE 26 The TI14 pinout of the ADA-ISO-TI14-E probe. Top view.

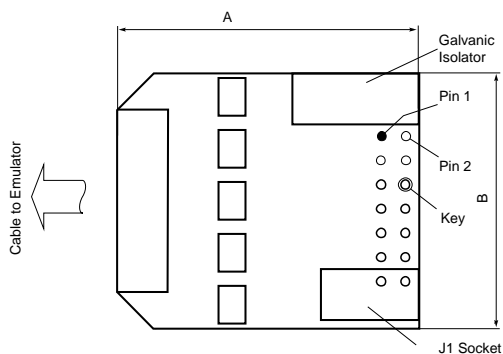

FIGURE 27 The dimensions of the 20-pin ADA-ISO-TI14-E probe. Top view. A = 32.4 mm (1.28 in), B = 28.5 mm (1.12 in).

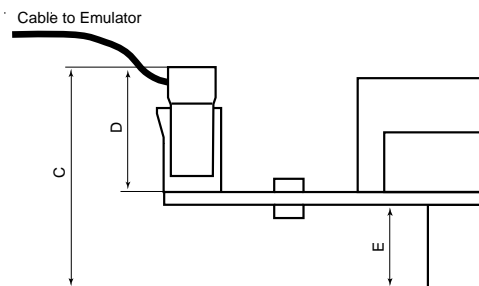

FIGURE 28 The ADA-ISO-TI14-E probe. Side view. C = 20.5 mm (.81 in.), D = 14.2 mm (0.56 in.), E = 8.5 mm (0.33 in.).

Compact TI 20-pin JTAG probe for DaVinci

ADA-JET-CTI20

The Signum JTAG ADA-JET-CTI20 probe provides a physical interface between the Signum JTAGjet-eBinder emulator and DaVinci, DM and OMAP target boards. This probe has 20-pin receptacles. The pin-to-pin X spacing is 0.10 in., Y spacing 0.05 in. The female connector on the probe is SAMTEC RSM-110-02-S-D. This is a low voltage probe operating in the 1.8 – 3.3V ($\pm 10\%$) range. **Figure 30** shows the probe's pinout.

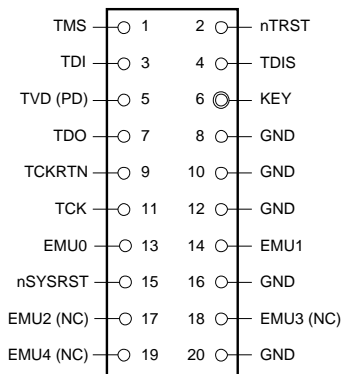
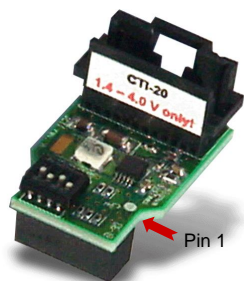

FIGURE 29 The ADA-JET-CTI20 probe for the Signum JTAGjet-eBinder emulator.

FIGURE 30 The cTI20 pinout of the ADA-JET-CTI20 probe. Top view.

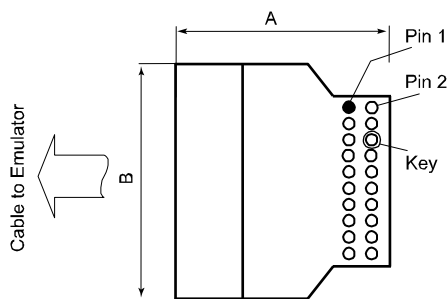

FIGURE 31 Dimensions of the 20-pin CTI20 probe. Top view. A = 27.0 mm (1.06 in.) B = 17.8 mm (0.70 in.).

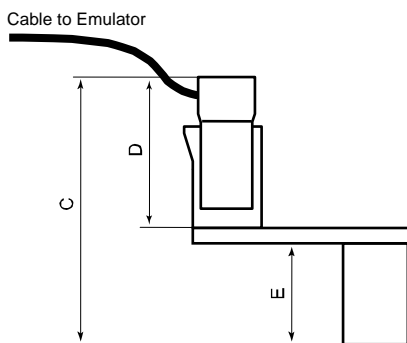

FIGURE 32 Dimensions of the 20-pin CTI20 probe. Side view. C = 23.0 mm (.91 in.), D = 12.5 mm (0.49 in.), E = 6.4 mm (0.25 in.).

The 4-position DIP switch on the CTI20 probe allows you to convert the EMU0 or EMU1 to a CPU reset line (**Figure 33**).

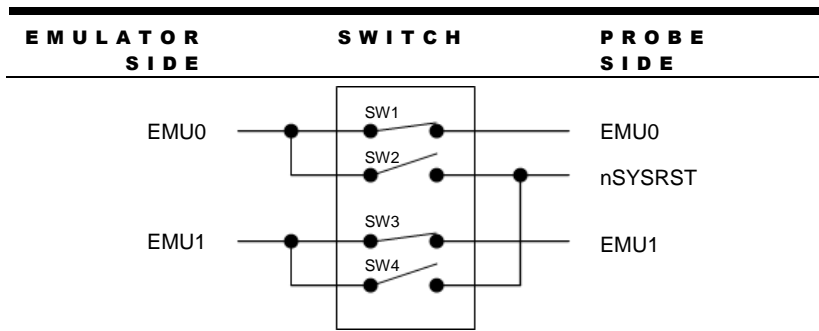

FIGURE 33 The DIP switches SW1-4 on the CTI20 probe in default setting positions.

	S W 1	S W 2	S W 3	S W 4
Default – EMU01 and EMU1 controlled in standard way	ON	OFF	ON	OFF
Emulator’s EMU0 connected to CTI20 probes’s nSYSRST	OFF	ON	ON	OFF
Emulator’s EMU1 connected to CTI20 probe’s nSYSRST	ON	OFF	OFF	ON
EMU0, EMU1 and nSYSRST disconnected from target (only weak pull-up resistors used)	OFF	OFF	OFF	OFF

TABLE 5 The allowed settings of the ADA-JET-CTI20 probe.

- Note 1** Set the SW1-4 switches only when the emulator and the target are not powered!
- Note 2** Do not set SW1-2 and SW3-4 pairs both ON. The setting will short the EMU0, EMU1 and nSYSRST lines on the target.
- Note 3** The nSYSRST, EMU0 and EMU1 lines are bi-directional and are driven by an open-collector gate in the emulator. EMU0 and EMU1 have 100K pull-ups to the PD pin on the probe side, while nSYSRST has 220K pull-up to the PD pin.
- Note 4** Certain JTAGjet driver packages may not easily allow configuring EMU0 and EMU1 as nSYSRST. Therefore it is recommended to leave the DIP switch in its default position. The software is unable to determine the position of this switch automatically. When SW2 or SW4 are ON, the software needs to be configured accordingly. Sample settings that allow EMU0 to act as a CPU reset signal (nSYSRST) are shown in **Figure 34**.

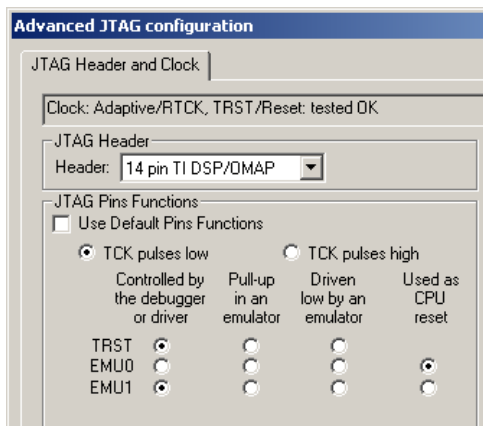

FIGURE 34 Configuring the JTAGjet-eBinder driver to use the EMU0 signal as the CPU reset signal (EmuDiag for the JTAGjet-eBinder).

All future releases of the JTAGjet software will allow the user to redefine the EMU0 and EMU1 pins as CPU reset pins.

ETM Connector for ARM & OMAP

The JTAGjet-Trace series emulators come with an Embedded Trace Macrocell (ETM) cable terminated with a 38-pin Mictor connector. This connector is polarized and cannot be inserted the wrong way.

ARM SIGNAL	OMAP SIGNAL	ETMV3 SIGNAL	PIN		ETMV3 SIGNAL	OMAP SIGNAL	ARM SIGNAL
No connect	No connect	No connect	1	2	No connect	No connect	No connect
No connect	No connect	No connect	3	4	No connect	No connect	No connect
GND	GND	GND	5	6	TRACECLK	TRACECLK	TRACECLK
DBGQRQ	EMU0	DBGQRQ	7	8	DBGACK	EMU1	DBGACK
nSRST	CPU_RESET	nSRST	9	10	EXTTRIG	EXTTRIG	EXTTRIG
TDO	TDO	TDO	11	12	vTref	vTref (ETM)	vTref
RTCK	TCK_RET	RTCK	13	14	vSupply	PD (JTAG)	vSupply
TCK	TCK	TCK	15	16	TRACEDATA[7]	TRACEPKT[7]	TRACEPKT[7]
TMS	TMS	TMS	17	18	TRACEDATA[6]	TRACEPKT[6]	TRACEPKT[6]
TDI	TDI	TDI	19	20	TRACEDATA[5]	TRACEPKT[5]	TRACEPKT[5]
nTRST	TRST'	nTRST	21	22	TRACEDATA[4]	TRACEPKT[4]	TRACEPKT[4]
TRACEPKT[15]	TRACEPKT[15]	TRACEDATA[15]	23	24	TRACEDATA[3]	TRACEPKT[3]	TRACEPKT[3]
TRACEPKT[14]	TRACEPKT[14]	TRACEDATA[14]	25	26	TRACEDATA[2]	TRACEPKT[2]	TRACEPKT[2]
TRACEPKT[13]	TRACEPKT[13]	TRACEDATA[13]	27	28	TRACEDATA[1]	TRACEPKT[1]	TRACEPKT[1]
TRACEPKT[12]	TRACEPKT[12]	TRACEDATA[12]	29	30	GND	TRACEPKT[0]	TRACEPKT[0]
TRACEPKT[11]	TRACEPKT[11]	TRACEDATA[11]	31	32	GND	TRACESYNC	TRACESYNC
TRACEPKT[10]	TRACEPKT[10]	TRACEDATA[10]	33	34	vTref (high)	PIPESTAT[2]	PIPESTAT[2]
TRACEPKT[9]	TRACEPKT[9]	TRACEDATA[9]	35	36	TRACECTL	PIPESTAT[1]	PIPESTAT[1]
TRACEPKT[8]	TRACEPKT[8]	TRACEDATA[8]	37	38	TRACEDATA[0]	PIPESTAT[0]	PIPESTAT[0]

TABLE 6 The pinout of the ETM connector.

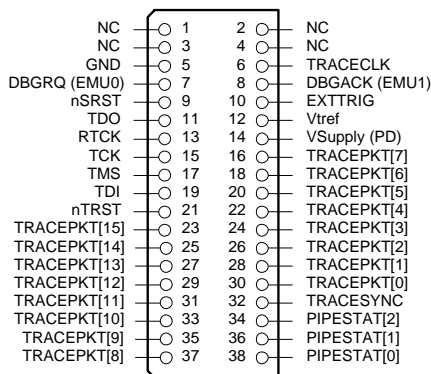

FIGURE 35 The pinout of the ETM38 connector when used with ARM targets.

JTAG-ETM Splitter Probe

ADA-ETM-JTAG

A typical target board has both the JTAG signals and the ETM signals connected to the same standard 38-pin ETM Mictor connector (see on p. 14). Some boards, however, separate the two types of signals, providing two different connectors for them. These boards require a JTAG-ETM splitter probe, ADA-ETM-JTAG. This probe is also useful when debugging an ARM or a DSP target board that does not have an ETM connector on it.

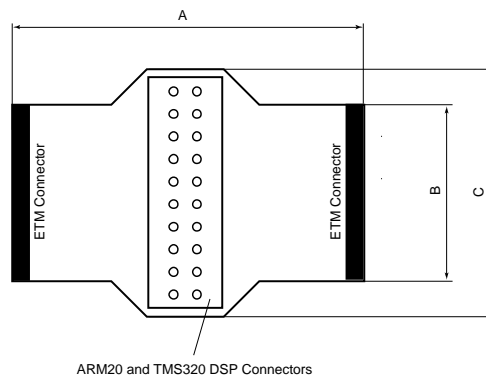
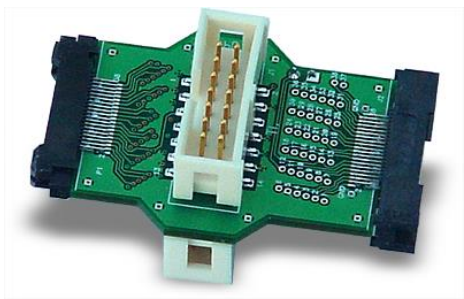

FIGURE 36 The JTAG-ETM splitter probe.

FIGURE 37 The dimensions of the JTAG-ETM splitter board. A = 52.0 mm (2.05 in), B = 25.4 mm (1 in), C = 33.9 mm (1.34 in).



FIGURE 38 The JTAG-ETM splitter board attached to the JTAGjet-Trace emulator. Connected to it are a 20-pin ARM JTAG cable and an ETM Mictor cable (lower). A receptacle for an additional 14-pin TMS320 DSP JTAG cable is located at the bottom of the board.

Passive 20-pin Probe for Cortex ETM trace

ADA-ETM-SWD20

This passive probe provides an interface between the Signum JTAGjet-Trace emulator and the 20-pin high-density connector on a Cortex target board. The pinout of the probe's Cortex connector is the same as the pinout of the ADA-ARM20-SWD probe's 20-pin connector (Figure 41). The probe's ETM connector has the pinout of ETM connector when used with ARM targets (Figure 42).

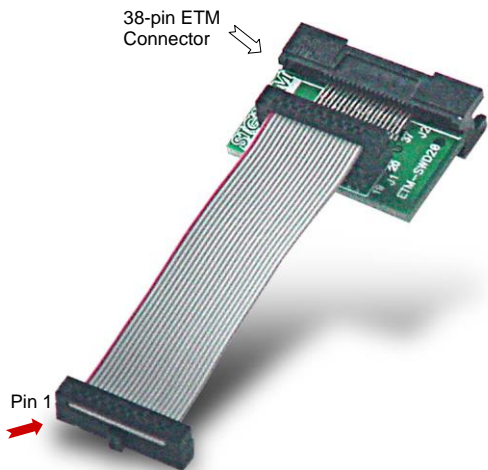

FIGURE 39 The ADA-ETM-SWD20 probe for Cortex boards with ETM trace.

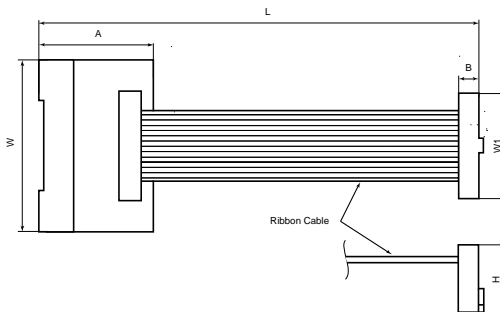

FIGURE 40 The dimensions of the ADA-ETM-SWD20 probe. A = 19.12 mm (0.75 in), B = 3.11 mm (0.122 in), H = 5.1 mm (0.2 in), W1 = 16.9 mm (0.67), W = 25.7 (1.01 in), L = 65.5 mm (2.58 in).

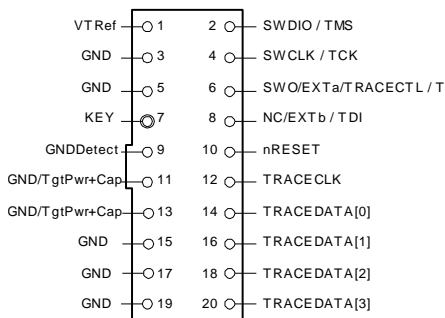

FIGURE 41 The Cortex20 pinout of the Cortex side of the ADA-ETM-SWD20 probe. Top view.

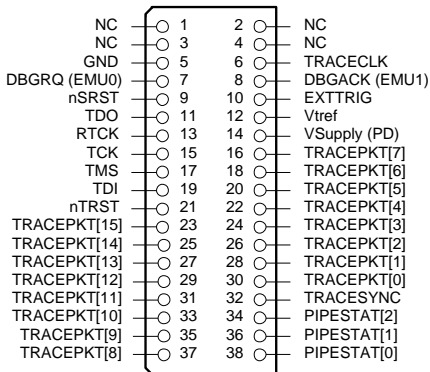

FIGURE 42 The ETM32 pinout of the ETM side of the ADA-ETM-SWD20 probe. Top view.

Active 12-pin MPSD Probe

ADA-JET-MPSD

The Signum MPSD (modular port scan device) probe ADA-JET-MPSD provides a physical interface between JTAGjet emulators for the TMS320 3x family of DSPs and target boards. The probe has 12 double-row, polarized, 2.54 mm × 2.54 mm (.100" × .100") receptacles (female connectors). To ensure proper orientation, the header is keyed. The ADA-JET-MPSD is a 5V Texas Instruments MPSD legacy adapter designed specifically for the Signum JTAGjet-C3x in-circuit emulator. It allows emulation at a maximum speed of 60 MHz. For the pinout, see **Figure 44**.

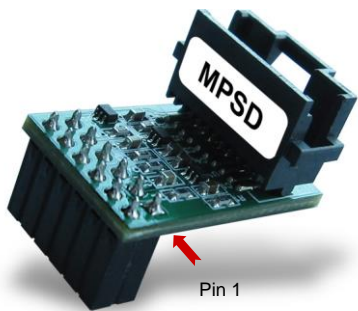

FIGURE 43 The ADA-JET-MPSD probe for TMS320 3x DSPs.

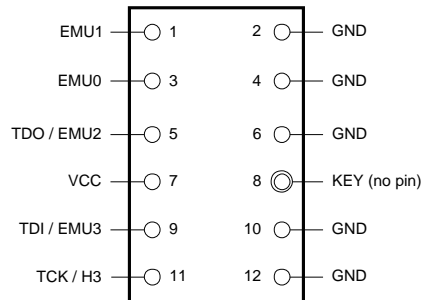

FIGURE 44 Pinout of the 12-pin ADA-JET-MPSD adapter for TMS320 3x DSPs.

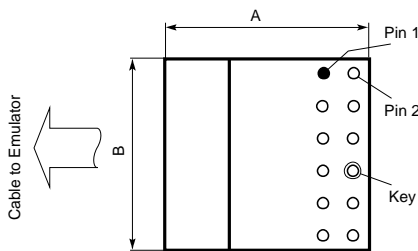

FIGURE 45 Dimensions of the ADA-JET-MPSD adapter. Top view. A = 24.8 mm (.98 in.), B = 17 mm (.67 in.).

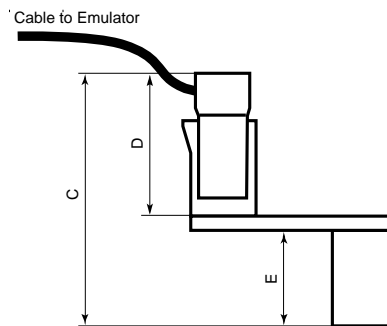

FIGURE 46 Dimensions of the ADA-JET-MPSD adapter. Side view. C = 21 mm (.82 in.), D = 11.5 mm (0.45 in.), E = 8.5 mm (0.34 in.).



X-ON Electronics

Largest Supplier of Electrical and Electronic Components

Click to view similar products for [Sockets & Adapters](#) category:

Click to view products by [IAR Systems](#) manufacturer:

Other Similar products are found below :

[6508-0-00-01-00-00-33-0](#) [AC164341](#) [AC164348](#) [1262](#) [22827](#) [AC164353](#) [TDGL015](#) [ATF15XXDK3-SAA100](#) [SA247](#) [SM64TQ-ACTEL-1](#)
[70-0036](#) [DS91230+](#) [SMPA-ISP-ACTEL-3-KIT](#) [16017](#) [KIT 70601-3](#) [SM132CQ-ACTEL](#) [IPC0181](#) [IPC0175](#) [IPC0165](#) [AC164397](#) [conga-](#)
[Thin MITX/eDP to DP Adapter](#) [ML-ADP-EVN](#) [ASA.01](#) [ASA.09](#) [ASA.12](#) [ASA.14](#) [MIKROE-425](#) [C305000ACP2](#) [110-83-320-41-605101](#)
[110-83-632-41-605101](#) [110-83-640-41-605101](#) [110-83-628-41-605101](#) [116-83-306-41-001101](#) [PA0003](#) [PA0007](#) [PA0009](#) [PA0035](#) [PA0085](#)
[PA0096](#) [IPC0079](#) [ATARD-DBGADPT](#) [80-000286](#) [ATSTK600-RC88](#) [ATSTK600-SC06](#) [ATSTK600-RC78](#) [SPC560PADPT64S](#) [AC164345](#)
[AC164342](#) [14-351000-11-RC](#) [966927-1](#)