

IDO0H-210-IR

Intel® Atom™ Processor E3845
21.5" Outdoor Sunlight Readable Panel PC

Outdoor Series 21.5"



I/O View



Features

- Sunlight readable
- Vandal-proof IK06 glass protection



- Wireless support



- Front bezel IP65 and IP33-rated chassis



- Automatic panel brightness, air flow speed and system temperature balance system

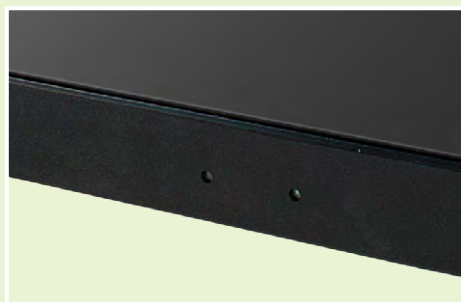

ID00H-210-IR

Specifications

Model No.	ID00H-210-IR	
Display & Touch Screen	Display Size	21.5" TFT-LCD
	Max. Resolution	1920 x 1080
	Luminance (cd/m ²)	Up to 1200nits, set default 75%
	Contrast	1000:1
	Max. Color	16.7M
	View Angle (H°/V°)	140/120
	Backlight Lifetime(hrs)	50000
	Touch Type	IR touch
	Touch Interface	USB
	Light Transmission (%)	88
	Point of touch	1
I/O Interface	USB 3.0	1
	USB 2.0	1
	RS-232/422/485 Selectable under BIOS	1
	RS-232	0
	LAN	2x GbE
	Additional Graphics	DP
	Audio	None
	Digital I/O	None
	Power Connector	AC inlet
	Power Button	Reset button
	Mechanical	Dimensions (mm)
Net Weight (kgs)		7.5
System	Processor	Intel® Atom™ Processor E3845 (Quad-Core @ 1.91 GHz)
	Memory	2x DDR3L SO-DIMM, up to 8GB, default DDR3L 4GB (4GBx1)
	Thermal Design	Fan
	Membrane Control	None
	Built-in Speaker/MIC	None
Expansion	Internal Expansion Bus	1x Mini PCI-E(x1) w/ USB signal [half-size] 1x mSATA/Mini PCI-E(x1) w/ USB signal and mSATA supported [full-size]
	Expansion Slot	None
	Wireless	Optional Wi-Fi/BT
Storage Space	HDD	1x 2.5" SATA
	Removable	None
Power	Power Input Range	90V ~ 240V AC
Construction	Chassis Material	Aluminum front bezel, black painting Black painting SGCC + Aluminum chassis
	Color (Front/Back)	Black/Black
	IP Rating	IP65 front bezel
	Mounting	Open frame rack mounting VESA 200x200 and 200x100 mm
Environmental	Operating Temperature	Low Temperature: -40°C with installed heater inside High Temperature: W/ 1120 W/m ² solar energy: 44 °C W/ 900 W/m ² solar energy: 50 °C
	Storage Temperature	-20°C ~ 60°C
	Storage Humidity	5%~90% @ 50°C, (non-condensing)
	Certification	CE/FCC Class B
	Supported Operating Systems	Windows 8 32/64 bit, Windows 7 Pro for Embedded 64 bit, WES7 64 bit

01

Vertical Applications
Panel PC

02

Stainless Steel
Panel PC

03

All-In-one Panel
PC with Riser Card
Expansion

04

Compact Panel PC

05

Heavy-duty
Industrial Panel PC

06

ARM-Based
Panel PC

07

ARM-Based HMI

IDOOH-210-IR

Dimensions

IDOOH-210-IR

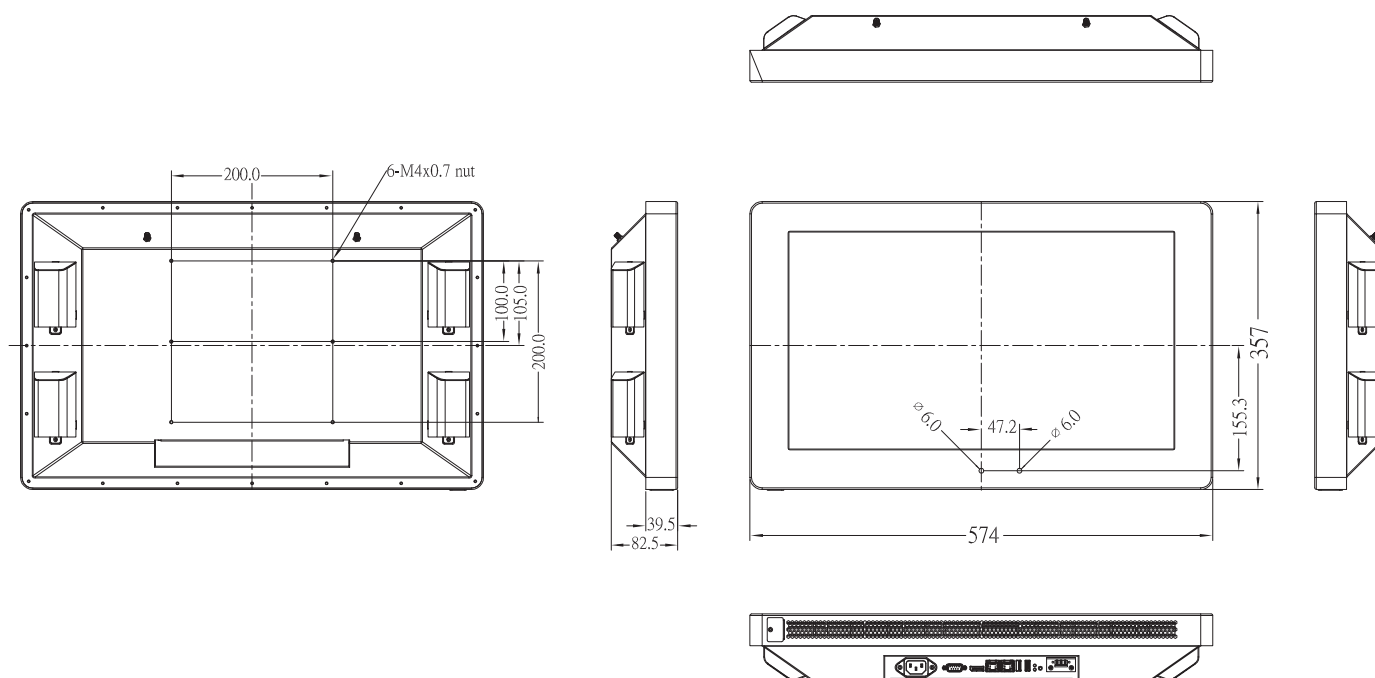

Ordering Information

IDOOH-210-IR

21.5" (1920 x 1080) Outdoor Panel PC with I8897, Intel® Atom™ Processor E3845 1.91GHz, 4GB DDR3L SO-DIMM, 64G SSD, IR touch

01

Vertical Applications
Panel PC

02

Stainless Steel
Panel PC

03

All-in-one Panel PC with
Riser Card Expansion

04

Compact Panel PC

05

Heavy-duty
Industrial Panel PC

06

ARM-Based
Panel PC

07

ARM-Based HMI

X-ON Electronics

Largest Supplier of Electrical and Electronic Components

Click to view similar products for [Panel PCs category](#):

Click to view products by [Ibase manufacturer](#):

Other Similar products are found below :

[GOT-5100T-832](#) [GOT-3126T-832](#) [BYARM-W071-PC](#) [STC-15WR-E3950,4G,64GB M.2](#) [STC-15WP-E3950,4G,64GB M.2](#) [POC-W152-C11D-ACE](#) [PWS-770-VMOUNT00E](#) [PWS-870-CHDC00E](#) [PWS-870-UCOVER00E](#) [TPC-31T-E3AE](#) [TREK-572-LWB7B0E](#) [ESRP-HMI-TPC1551](#) [ESRP-HMI-TPC1251](#) [ESRP-HMI-TPCB200](#) [BYARM-181-PC](#) [BYTEM-121-PC](#) [IDOOH-210-IR](#) [AFL3-W15A-BT-J1/PC/2G-R13](#) [IOVU-07F-AD-WBC-R10](#) [003002400100](#) [1050387](#) [SPTM20XP](#) [XPTB10X](#) [UTC-W101BF-ABI0E](#) [UTC-W101B-ABI0E](#) [UTC-W101B-AWI0E](#) [UTC-532C-GE](#) [UTC-532A-GE](#) [UTC-520A-PE](#) [UTC-520A-GE](#) [TREK-722R-A1E](#) [TREK-570-00A0E](#) [PWS-870-7S6G4P5F0E](#) [PPC-174T-WL-MTE](#) [110070048](#)