

IPC-2520AB-XXX-M Power Choke

| Part No. | Inductance L0(μ H) \pm 20%, 1MHz, 1V | DCR (m Ω) | | IDC3 Typ.(Amps) | Isat4 @ 25°C Typ.(Amps) |
|------------------|---|-------------------|------|--------------------|----------------------------|
| | | TYP. | MAX. | | |
| IPC-2520AB-R33-M | 0.33 | 14 | 17 | 5.6 | 4.3 |
| IPC-2520AB-R47-M | 0.47 | 20 | 25 | 4.5 | 3.8 |
| IPC-2520AB-1R0-M | 1.00 | 43 | 53 | 3.1 | 2.8 |
| IPC-2520AB-2R2-M | 2.20 | 84 | 98 | 2.3 | 1.8 |

Notes

1. All test data is referenced to 25 °C ambient
2. Operating temperature range - 55 °C to + 125 °C
3. Idc(A):DC current (A) that will cause an approximate ΔT of 40 °C
4. Isat(A):DC current (A) that will cause L0 to drop approximately 30 %
5. The part temperature (ambient + temp rise) should not exceed 125 °C under worst case operating conditions. Circuit design component placement, PWB trace size and thickness, airflow and other cooling provisions all affect the part temperature. Part temperature should be verified in the end application.

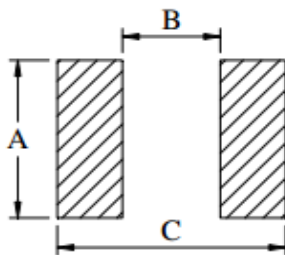
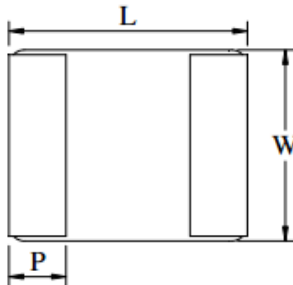

| Code | Dimensions |
|------|---------------|
| L | 2.5 \pm 0.2 |
| W | 2.0 \pm 0.2 |
| T | 1.2MAX. |
| P | 0.6 \pm 0.2 |

Unit: mm

| | |
|---|-----|
| A | 2.0 |
| B | 1.2 |
| C | 2.8 |

Unit: mm

Recommend Land Pattern Dimensions

FEATURES

- Lowest molded height (1.2 mm) in this package Footprint.
- Shielded construction
- Frequency range up to 3.0 MHz
- Lowest DCR/ μ H, in this package size
- Handles high transient current spikes without saturation
- Ultra low buzz noise, due to composite construction
- Encapsulated body offers improved environmental protection and moisture resistance.
- Higher dielectric withstanding voltage vs. IHLP
- Flame retardant encapsulant (UL 94 V-0)
- Corrosion resistant package
- Compliant to RoHS directive 2011/65/EU

APPLICATIONS

- PDA/notebook/desktop/server applications
- High current POL converters
- Low profile, high current power supplies
- Battery powered devices
- DC/DC converters in distributed power systems
- DC/DC converter for Field Programmable Gate Array (FPGA)

| Description | | | | |
|--------------------|---|------------------|---|----------------------|
| IPC-2520AB-1R0 | | 1.0 μ H | | ±20 % |
| Model | | Inductance Value | | Inductance Tolerance |
| Global Part Number | | | | |
| I | P | C | 2 | 5 |
| | | | 2 | 0 |
| A | | B | | 1 |
| | | | | R |
| | | | | 0 |
| | | | | M |
| Product Series | | Dimensions | | Thickness |
| | | | | Inductance Value |
| | | | | Tol. |

Performance Graphs

Test Instruments

Wayne kerr 3255B/G LCR Meter
Wayne kerr 3265B Bias Current Source

Test Condition

Temperature: $26 \pm 3^{\circ}\text{C}$
Humidity: < 70% RH
Frequency: 100 KHz, 1.0V

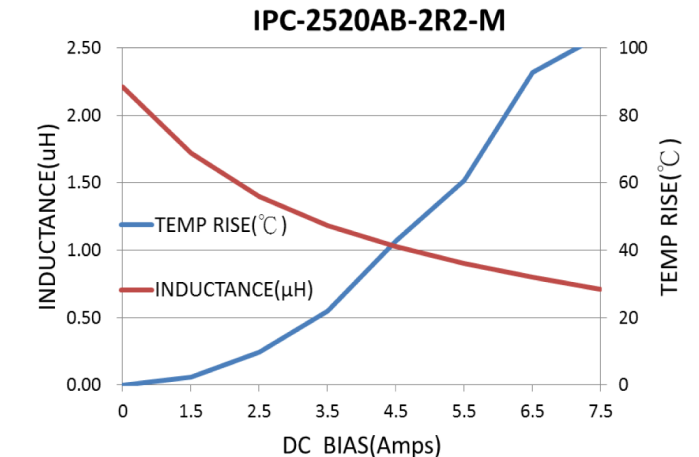
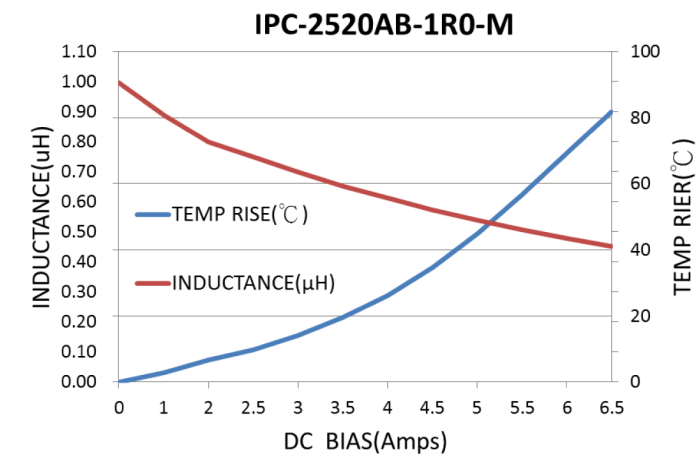
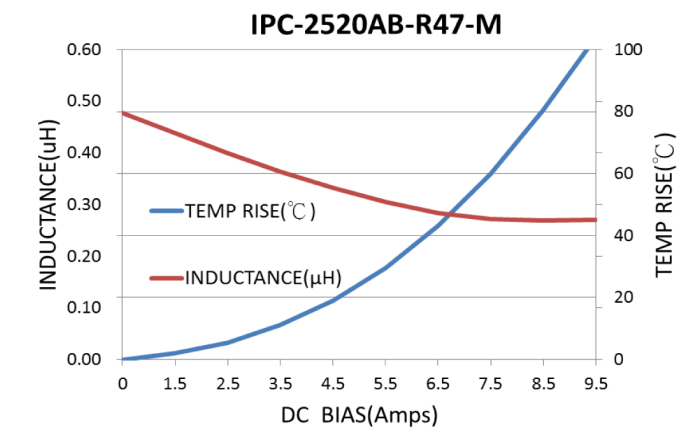
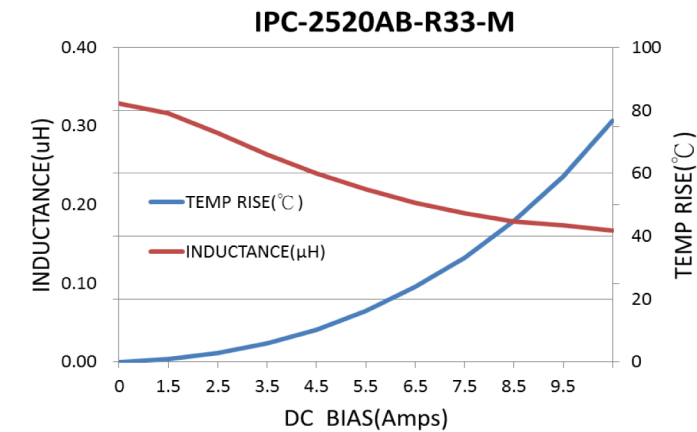

| Mechanical Reliability | | |
|------------------------|---|--|
| Item | Specification and Requirement | Test Method |
| Solderability | The surface of terminal immersed shall be minimum of 95% covered with a new coating of solder | Solder heat proof: 1. Preheating: 160 ± 10 °C 2. Retention time: 245 ± 5 °C for 2 ± 0.5 seconds |
| Vibration | Inductance change: Within $\pm 5\%$ Without mechanical damage such as break | 3. Vibration frequency: (10 Hz to 55 Hz to 10Hz) in 60 seconds as a period 4. Vibration time: Period cycled for 2 hours in each of 3 mutual perpendicular directions. 5. Amplitude: 1.5 mm max. |
| Shock | Inductance change: Within $\pm 5\%$ Without mechanical damage such as break | 1. Peak value: 100 G 2. Duration of pulse: 11ms 3. 3 times in each positive and negative direction of 3 mutual perpendicular directions |
| Endurance Reliability | | |
| Item | Specification and Requirement | Test Method |
| Thermal Shock | Inductance change: Within $\pm 5\%$ Without distinct damage in appearance | 1. Repeat 100 cycles as follow: (-55 ± 2 °C; 30 ± 3 min) →(Room temp., 5 min) → ($+125 \pm 2$ °C, 30 ± 3 min) → (Room temp., 5 min) 2. Recovery: $48 + 4 / -0$ hours of recovery under the standard condition after the test. (see Note a*) |
| Humidity Resistance | Inductance change: Within $\pm 5\%$ Without distinct damage in appearance | 1. Environment condition: 85 ± 2 °C Humidity: 80–85% Applied Current: Rated current 2. Duration: $168 + 4 / -0$ hours (see Note a*) |
| Low Temperature Store | Inductance change: Within $\pm 5\%$ Without distinct damage in appearance | Store temperature: -55 ± 2 °C, $168 + 4 / -0$ hours |
| High Temperature Store | Inductance change: Within $\pm 5\%$ Without distinct damage in appearance | Store temperature: $+125 \pm 2$ °C, $168 + 4 / -0$ hours |

Note a*: When there are questions concerning measurement result : measurement shall be made after 48 ± 2 hours of recovery under the standard condition

Reflow Chart

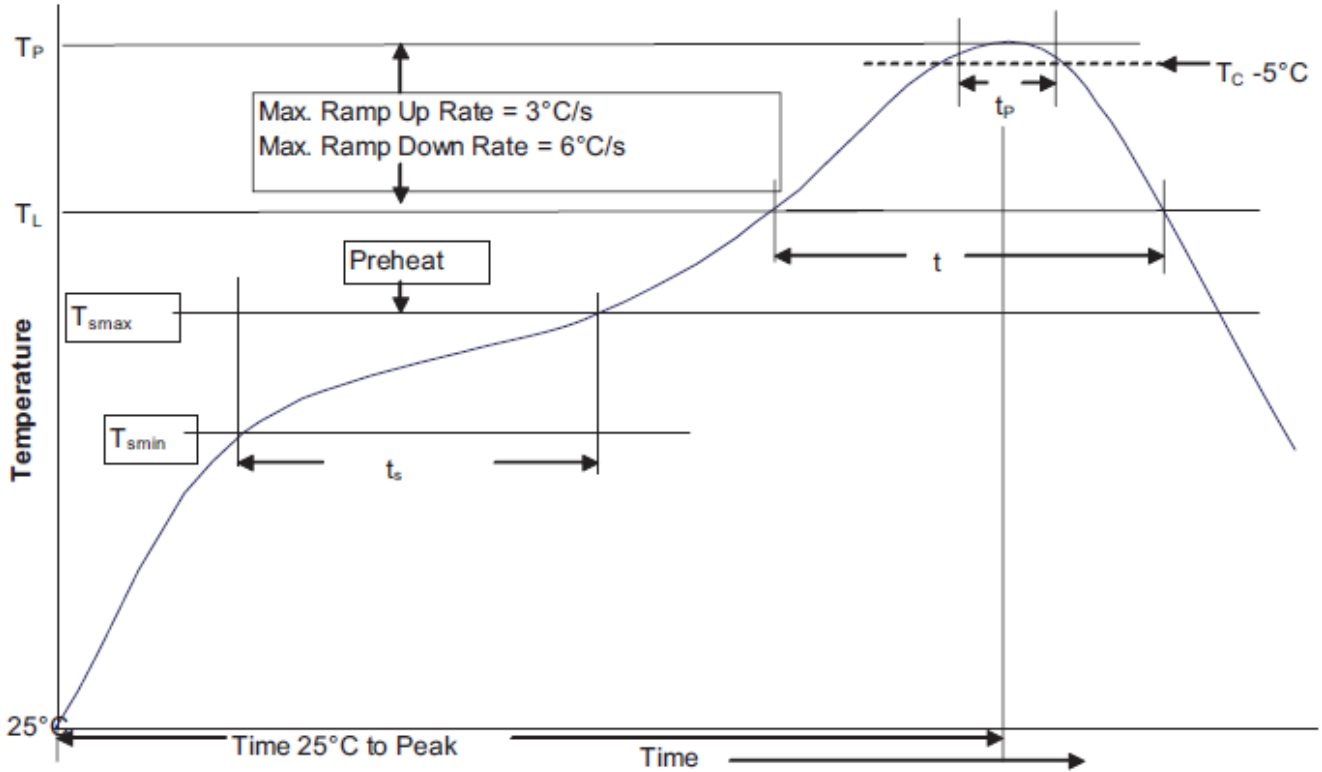

Reference JEDEC J-STD-020D

| Profile Feature | Standard SnPb Solder | Lead (Pb) Free Solder |
|--|----------------------|-----------------------|
| Preheat and Soak | | |
| • Temperature min. (T_{smin}) | 100°C | 150°C |
| • Temperature max. (T_{smax}) | 150°C | 200°C |
| • Time (T_{smin} to T_{smax}) (t_s) | 60-120 Seconds | 60-120 Seconds |
| Average ramp up rate T_{smax} to T_p | 3°C/ Second Max. | 3°C/ Second Max. |
| Liquidous temperature (T_L) | 183°C | 217°C |
| Time at liquidous (t_l) | 60-150 Seconds | 60-150 Seconds |
| Peak package body temperature (T_p)* | Table 1 | Table 2 |
| Time (t_p)** within 5 °C of the specified classification temperature (T_C) | 20 Seconds** | 30 Seconds** |
| Average ramp-down rate (T_p to T_{smax}) | 6°C/ Second Max. | 6°C/ Second Max. |
| Time 25°C to Peak Temperature | 6 Minutes Max. | 8 Minutes Max. |

* Tolerance for peak profile temperature (T_p) is defined as a supplier minimum and a user maximum.

** Tolerance for time at peak profile temperature (t_p) is defined as a supplier minimum and a user maximum.

Table 1 - Standard SnPb Solder (T_C)

Table 2 - Lead (Pb) Free Solder (T_C)

| Package Thickness | Volume <350 mm ³ | Volume ≥ 350 mm ³ |
|-------------------|-------------------------------|-----------------------------------|
| <2.5 mm | 235°C | 220°C |
| ≥ 2.5 mm | 220°C | 220°C |

| Package Thickness | Volume <350 mm ³ | Volume 350 - 2000 mm ³ | Volume >2000 mm ³ |
|-------------------|-------------------------------|-----------------------------------|--------------------------------|
| <1.6 mm | 260°C | 260°C | 260°C |
| 1.6 - 2.5mm | 260°C | 250°C | 245°C |
| >2.5 mm | 250°C | 245°C | 245°C |

Tape Packaging Dimensions

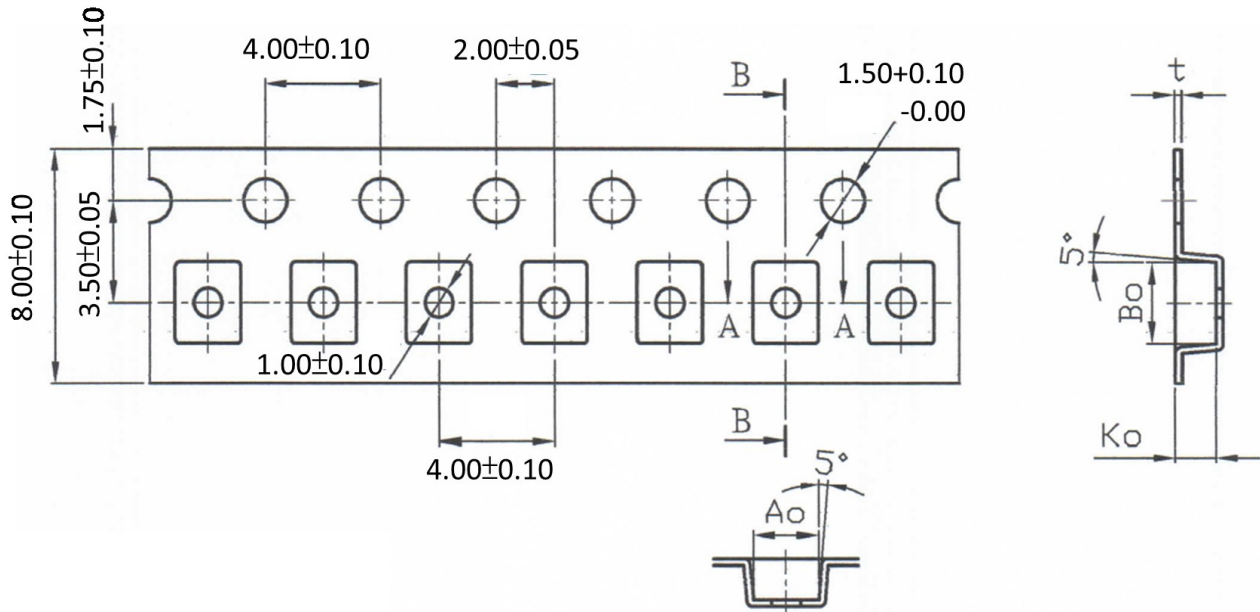

| Series | A0 | B0 | K0 | t |
|------------|-----------------|-----------------|-----------------|-----------------|
| IPC-2520AB | 2.27 ± 0.10 | 2.74 ± 0.10 | 1.40 ± 0.10 | 0.23 ± 0.05 |

Reel Dimensions

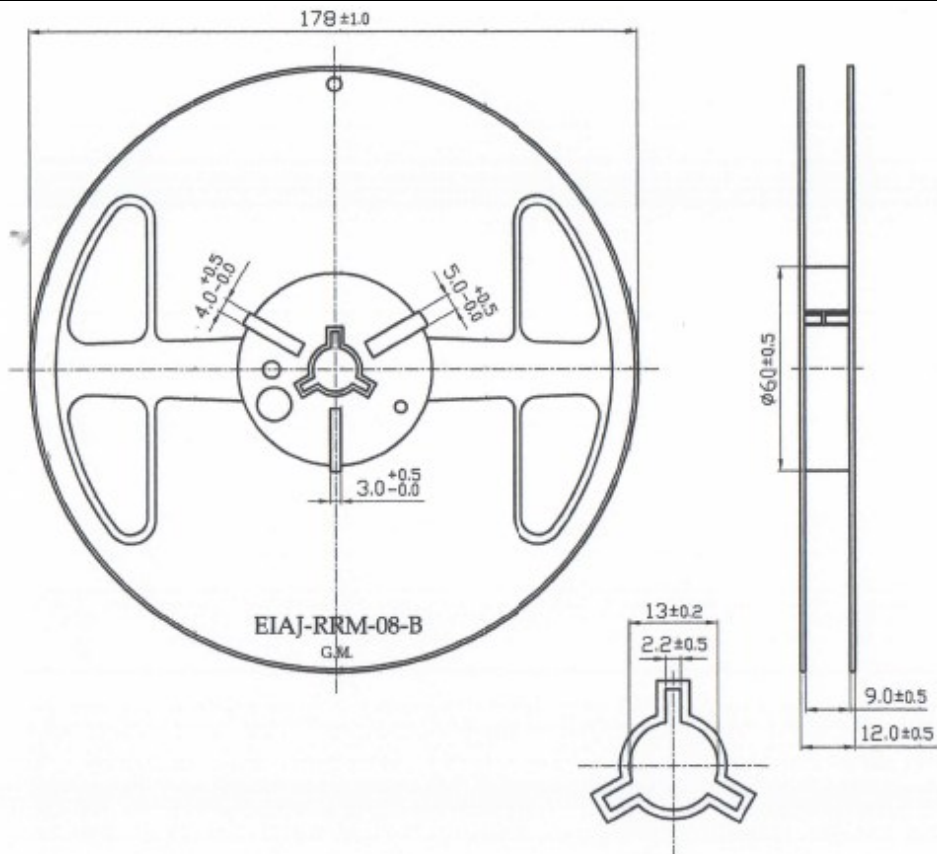

- Peel force of top cover tape

The peel speed shall be about 300mm/minute

The peel force of top cover tape shall be between 0.1 to 0.7 N

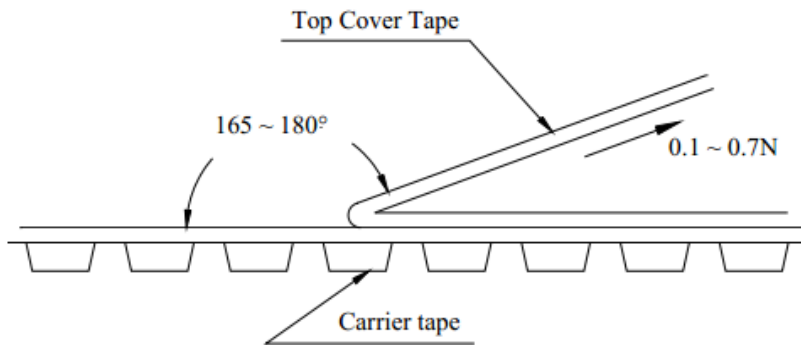

- Numbers of taping

3000pieces/reel

- Label making

The following items shall be marked on the production and shipping.

Label on the reel.

- Production Label

- Model.
- P/N.
- Quantity
- Lot No.

• Care note

• Care note for Use

(1) Storage Condition:

Room Temperature, Humidity 60% RH

(2) Use Temperature:

a. Minimum Temperature: -55°C Ambient temperature of power choke coil.

b. Maximum Temperature: $+125^{\circ}\text{C}$ The value of temperature including ambient of the transformer and temperature rise of power choke coil.

c. There is not a problem form $-55^{\circ}\text{C}\sim+125^{\circ}\text{C}$ in a reliability test.

d. However, this is not meant a temperature grade guarantee of UL.

(3) Model:

When this power choke coil was used in a similar or new product to the original one,

Something it might be unable to satisfy the specifications due to difference of condition of usage.

(4) Drop:

If the power choke coil suffered mechanical stress such as drop, characteristics may become poor (due to damage on coil bobbin, etc.)

Never use such stressed power choke coil.

- Care note for Safety

- (1) Provision to Abnormal Condition

This power choke coil itself does not have any protective function in abnormal condition such as overload, Short-circuit and open-circuit conditions, etc.

Therefore, it shall be confirmed as the end product that there is no risk of smoking, fire, dielectric withstand voltage, Insulation resistance ,etc. in abnormal conditions to provide protective devices and/or protection circuit in the end product.

- (2) Temperature Rise

Temperature rise of power choke coil depends on the installation condition end products.

It shall be confirmed on the actual end product that temperature rise of power choke coil is in the limit of specified temperature class.

- (3) Dielectric Strength

Dielectric withstanding test with higher voltage than specific value will damage insulating material and shorten its life.

- (4) Water

This power choke coil must not be used in wet condition by water, coffee or any liquid because insulation strength becomes very low on the condition.

- (5) Potting

If this power choke coil is some compound, coating material of magnet wire might be occasionally damaged .

Please ask us if you intend to pot this power choke coil.

- (6) Detergent

Please consult our company once in case of this because the confirmation of reliability etc. is needed when the washing medicine is used for the power choke coil.

X-ON Electronics

Largest Supplier of Electrical and Electronic Components

Click to view similar products for [Fixed Inductors](#) category:

Click to view products by [ICE](#) manufacturer:

Other Similar products are found below :

[CR32NP-100KC](#) [CR43NP-680KC](#) [CR54NP-820KC](#) [CR54NP-8R5MC](#) [CTX32CT-100](#) [70F224AI](#) [MGDQ4-00004-P](#) [MHL1ECTTP18NJ](#)
[MHL1JCTTD12NJ](#) [PE-51506NL](#) [PE-53601NL](#) [PE-53602NL](#) [PE-53630NL](#) [PE-53824SNLT](#) [PE-62892NL](#) [PE-92100NL](#) [PG0434.801NLT](#)
[PG0936.113NLT](#) [9310-16](#) [PM06-2N7](#) [PM06-39NJ](#) [A01TK](#) [1206CS-471XJ](#) [HC2-2R2TR](#) [HC2LP-R47-R](#) [HC3-2R2-R](#) [HCF1305-3R3-R](#)
[1206CS-151XG](#) [RCH664NP-140L](#) [RCH664NP-4R7M](#) [RCH8011NP-221L](#) [RCP1317NP-332L](#) [RCP1317NP-391L](#) [RCR1010NP-470M](#)
[RCR110DNP-331L](#) [DH2280-4R7M](#) [DS1608C-106](#) [ASPI-4020HI-R10M-T](#) [B10TJ](#) [B82477P4333M](#) [B82498B3101J000](#) [B82498B3680J000](#)
[ELJ-RE27NJF2](#) [1812CS-153XJ](#) [1812CS-183XJ](#) [1812CS-223XJ](#) [1812LS-104XJ](#) [1812LS-105XJ](#) [1812LS-124XJ](#) [1812LS-154XJ](#)