



AiP384X High Performance Current Mode PWM Controller

Product Specification

Specification Revision History :

| Version | Date | Description |
|----------------|-------------|---|
| 2019-07-A1 | 2019-07 | New |
| 2020-01-A2 | 2020-01 | Add Ordering Information |
| 2021-07-A3 | 2021-07 | Add Operating Temperature and Storage Temperature |
| | | |



1、 General Description

The AiP3842/AiP3843/AiP3844/AiP3845 are fixed frequency current-mode PWM controller. They are specially designed for Off-Line and DC-to-DC converter applications with minimum external components. These integrated circuits feature a trimmed oscillator for precise duty cycle control, a temperature compensated reference, high gain error amplifier. Current sensing comparator, and a high current totempole output Ideally suited for driving a power MOSFET. Protection circuit Includes built in under-voltage lockout and current limiting. The AiP3842 and AiP3844 have UVLO thresholds of 16V (on) and 10V (off). The AiP3843 and AiP3845 are 8.8V (on) and 7.6V (off) .The AiP3842 and AiP3843 can operate within 100% duty cycle. The AiP3844 and AiP3845 can operate with 50% duty cycle.

Features:

- Low Start Up Current
- Maximum Duty Clamp
- UVLO With Hysteresis
- Operating Frequency Up To 500KHz
- Packaging form: DIP8/SOP8
- Wide range of operating temperatures: -40°C to +85°C

Ordering Information:

Tube packing specifications:

| Type number | packaging form | Marking code | Tube quantity | Boxed tube quantity | Boxed quantity | Packing box number | Packing quantity | Notes |
|---------------|----------------|--------------|---------------|---------------------|----------------|--------------------|------------------|---|
| AiP384X SA.TB | SOP8 | AiP384X | 100 PCS/tube | 100 tube/box | 10000 PCS/box | 10 box/pack | 100000 PCS/pack | Dimensions of plastic enclosure: 4.9mm×3.9mm Pin spacing: 1.27mm |
| AiP384X DA.TB | DIP8 | AiP384X | 50 PCS/tube | 40 tube/box | 2000 PCS/ box | 10 box/pack | 20000 PCS/pack | Dimensions of plastic enclosure: 9.2mm×6.4mm Pin spacing: 2.54mm |

Reel packing specifications:

| Type number | packaging form | Marking code | Reel quantity | Boxed reel quantity | Packing quantity | Notes |
|--------------|----------------|--------------|---------------|---------------------|------------------|---|
| AiP384XSA.TR | SOP8(1) | AiP384X | 4000 PCS/reel | 8000 PCS/box | 64000 PCS/pack | Dimensions of plastic enclosure:4.9mm×3.9mm Pin spacing:1.27mm |
| AiP384XSA.TR | SOP8(2) | AiP384X | 2500 PCS/reel | 5000 PCS/box | 40000 PCS/pack | Dimensions of plastic enclosure:4.9mm×3.9mm Pin spacing:1.27mm |

Note: If the physical information is inconsistent with the ordering information, please refer to the actual product.



2、Block Diagram And Pin Description

2.1、Block Diagram

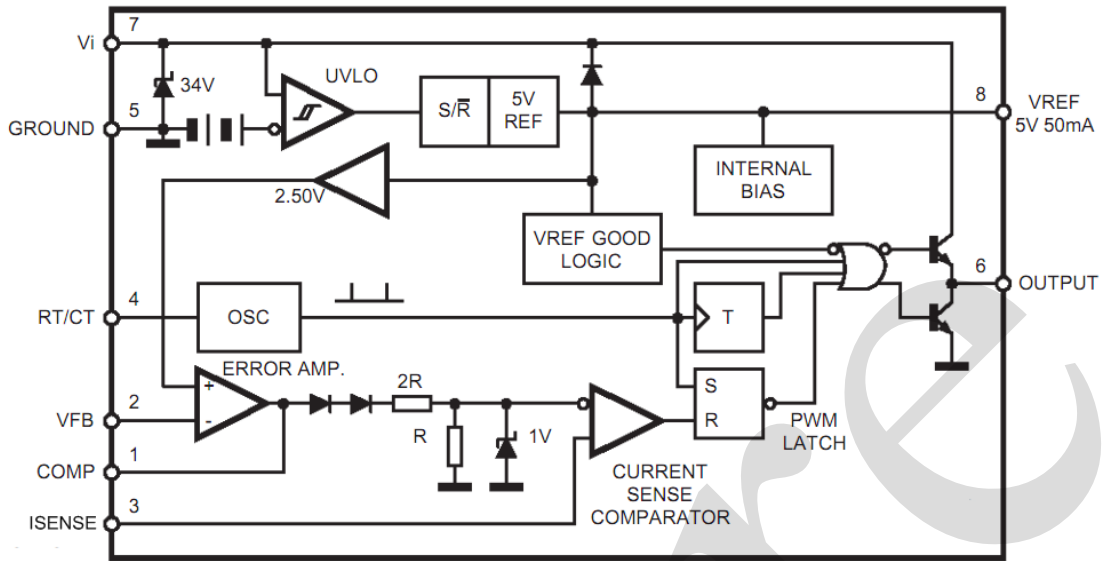

2.2、Pin Configurations

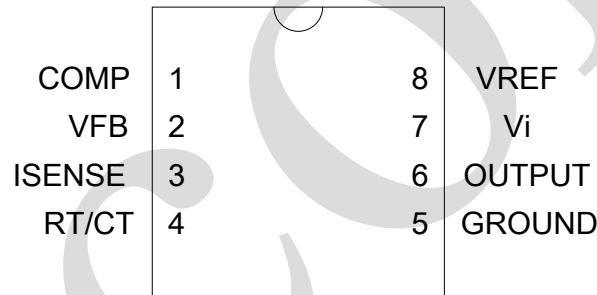

2.3、Pin Description

| Pin No. | Pin Name | Description |
|---------|----------|--|
| 1 | COMP | This pin is the Error Amplifier output and is made available for loop compensation. |
| 2 | VFB | This is the inverting input of the Error Amplifier. It is normally connected to the switching power supply output through a resistor divider. |
| 3 | ISENSE | A voltage proportional to inductor current is connected to this input. The PWM uses this information to terminate the output switch conduction. |
| 4 | RT/CT | The oscillator frequency and maximum Output duty cycle are programmed by connecting resistor RT to VREF and capacitor CT to ground. Operation to 500kHz is possible. |
| 5 | GROUND | This pin is the combined control circuitry and power ground. |
| 6 | OUTPUT | This output directly drives the gate of a power MOSFET. Peak currents up to 1A are sourced and sunk by this pin. |
| 7 | Vi | This pin is the positive supply of the control IC. |
| 8 | VREF | This is the reference output. It provides charging current for capacitor CT through resistor RT |



3、Electrical Parameter

3.1、Absolute Maximum Ratings

($T_{amb}=25^{\circ}\text{C}$, unless otherwise specified)

| Characteristic | Symbol | Conditions | Value | Unit | |
|---------------------------------------|----------------|------------|--------------|--------------------|--------------------|
| supply voltage (low impedance source) | V_i | - | 30 | V | |
| output current | I_O | - | ± 1 | A | |
| power dissipation | P_D | - | 1 | W | |
| error amplifier output sink current | $I_{sink}(EA)$ | - | 10 | mA | |
| analog inputs | $V_{in}(EA)$ | - | -0.3 to +6.3 | V | |
| operating temperature | T_{amb} | - | -40 to 85 | $^{\circ}\text{C}$ | |
| storage temperature | T_{stg} | - | -65 to 150 | $^{\circ}\text{C}$ | |
| soldering temperature | T_L | 10s | DIP8 | 245 | $^{\circ}\text{C}$ |
| | | | SOP8 | 250 | |

3.2、Electrical Characteristics

($T_{amb}=-40\sim 85^{\circ}\text{C}$, $V_i=15\text{V}$, $R_T=10\text{k}\Omega$, $C_T=3.3\text{nF}$, unless otherwise specified)

| Characteristic | Symbol | Conditions | Min. | Typ. | Max. | Unit |
|---|---------------------------|--|------|------|------|------------------------------|
| Reference Section | | | | | | |
| reference output voltage | V_{REF} | $I_o=1\text{mA}$ | 4.90 | 5.00 | 5.10 | V |
| line regulation | ΔV_{REF} | $12\text{V}\leq V_i\leq 25\text{V}$ | - | 2 | 20 | mV |
| load regulation | ΔV_{REF} | $1\leq I_o\leq 20\text{mA}$ | - | 3 | 25 | mV |
| short circuit output current | $\Delta V_{REF}/\Delta T$ | - | - | 0.2 | - | $\text{mV}/^{\circ}\text{C}$ |
| total output variation | - | line, load, temperature | 4.82 | - | 5.18 | V |
| output Noise voltage | eN | $10\text{Hz}\leq f\leq 10\text{KHz}$, $T_j=25^{\circ}\text{C}$ | - | 50 | - | μV |
| output Short circuit | I_{SC} | - | -30 | -100 | -180 | mA |
| Oscillator Section | | | | | | |
| frequency | f_{OSC} | $T_j=25^{\circ}\text{C}$ | 49 | 52 | 55 | kHz |
| | | $T_{amb}=T_{low}$ to T_{high} | 48 | - | 56 | kHz |
| | | $T_j=25^{\circ}\text{C}$ ($R_T=6.2\text{k}\Omega$, $C_T=1\text{nF}$) | 225 | 250 | 275 | kHz |
| frequency change with volt | $\Delta f_{OSC}/\Delta V$ | $V_i=12\text{V}\sim 25\text{V}$ | - | 0.2 | 1 | % |
| frequency change with temp. | $\Delta f_{OSC}/\Delta T$ | $T_{amb}=-40$ to 85°C | - | 0.5 | - | % |
| oscillator voltage swing | V_{OSC} | (peak to peak) | - | 1.6 | - | V |
| discharge current ($V_{OSC}=2\text{V}$) | I_{dischg} | $T_j=25^{\circ}\text{C}$, $T_{amb}=-40$ to 85°C | 7.8 | 8.3 | 8.8 | mA |
| Error AMP Section | | | | | | |
| input voltage | V_2 | $V_{PIN1}=2.5\text{V}$ | 2.42 | 2.50 | 2.58 | V |
| input bias current | I_b | $V_{FB}=5\text{V}$ | - | -0.1 | -2 | μA |
| - | A_{VOL} | $2\text{V}\leq V_o\leq 4\text{V}$ | 65 | 90 | - | dB |
| unity gain bandwidth | BW | $T_j=25^{\circ}\text{C}$ | 0.7 | 1 | - | MHz |



| | | | | | | |
|--------------------------------------|----------------|---|------|------|------|---------|
| power supply rejec.ratio | PSRR | $12V \leq V_i \leq 25V$ | 60 | 70 | - | dB |
| output sink current | I_O | $V_{PIN2}=2.7V, V_{PIN1}=1.1V$ | 2 | 12 | - | mA |
| output source current | I_O | $V_{PIN2}=2.3V, V_{PIN1}=5V$ | -0.5 | -1 | - | mA |
| VOUT High | $V_{OUT High}$ | $V_{PIN2}=2.3V;$ $R_L=15K\Omega$ to ground | 5 | 6.2 | - | V |
| VOUT Low | $V_{OUT Low}$ | $V_{PIN2}=2.7V;$ $R_L=15K\Omega$ to PIN 8 | - | 0.8 | 1.1 | V |
| Current Sense Section | | | | | | |
| Gain | G_V | - | 2.85 | 3 | 3.15 | V/V |
| maximum input signal | V3 | $V_{PIN1}=5V$ | 0.9 | 1 | 1.1 | V |
| supply voltage rejection | SVR | $12V \leq V_i \leq 25V$ | - | - | 70 | dB |
| input bias current | I_b | - | - | -2 | -10 | μA |
| delay to output | - | - | - | 150 | 300 | ns |
| Output Section | | | | | | |
| output Low level | V_{OL} | (Isink=20mA) | - | 0.1 | 0.4 | V |
| | | (Isink=200mA) | - | 1.6 | 2.2 | V |
| output High level | V_{OH} | (Isourse=20mA) | 13 | 13.5 | - | V |
| | | (Isourse=200mA) | 12 | 13.5 | - | V |
| UVLO saturation | V_{OLS} | $V_i=6V, I_{SINK}=1mA$ | - | 0.1 | 1.1 | V |
| rise time | t_r | $C_L=1nF$ | - | 50 | 150 | ns |
| fall time | t_f | $C_L=1nF$ | - | 50 | 150 | |
| Under-voltage Lockout Section | | | | | | |
| start threshold | $V_{TH(ST)}$ | AiP3842/4 | 14.5 | 16 | 17.5 | V |
| | | AiP3843/5 | 7.8 | 8.8 | 9.4 | V |
| min operating voltage after turn-on | $V_{OPR(MIN)}$ | AiP3842/4 | 8.5 | 10 | 11.5 | V |
| | | AiP3843/5 | 7.0 | 7.6 | 8.2 | V |
| PWM Section | | | | | | |
| maximum duty cycle | - | AiP3842/3 | 95 | 97 | 100 | % |
| | | AiP3844/5 | 47 | 48 | 50 | % |
| minimum duty cycle | - | - | - | - | 0 | % |
| Total Standby current | | | | | | |
| start-up current | I_{st} | $V_i=6.5V, AiP3843/5$ | - | 0.3 | 0.5 | mA |
| | | $V_i=14V, AiP3842/4$ | - | 0.3 | 0.5 | mA |
| operating supply current | I_i | $V_{PIN2}=V_{PIN3}=0V$ | - | 12 | 20 | mA |
| zener voltage | V_{iz} | $I_i=25mA$ | 30 | 36 | - | V |

Notes:

1. Max package power dissipation limits must be respected; low duty cycle pulse techniques are used during test maintain T_j as close to T_{amb} as possible.
2. These parameters, although guaranteed, are not 100% tested in production.
3. Parameter measured at trip point of latch with $V_{PIN2}=0$.
4. Gain defined as : $A=\Delta V_{PIN1}/\Delta V_{PIN3}; 0 \leq V_{PIN3} \leq 0.8V$
5. Adjust V_i above the start threshold before setting at 15V.



4、Typical Application Circuit

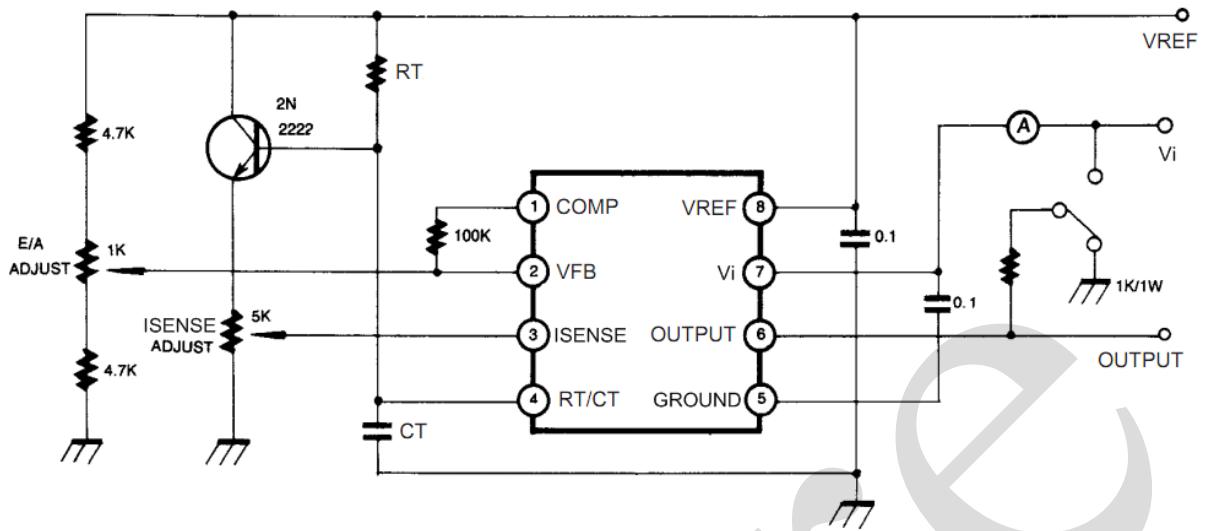



5、Package Information

5.1、DIP8

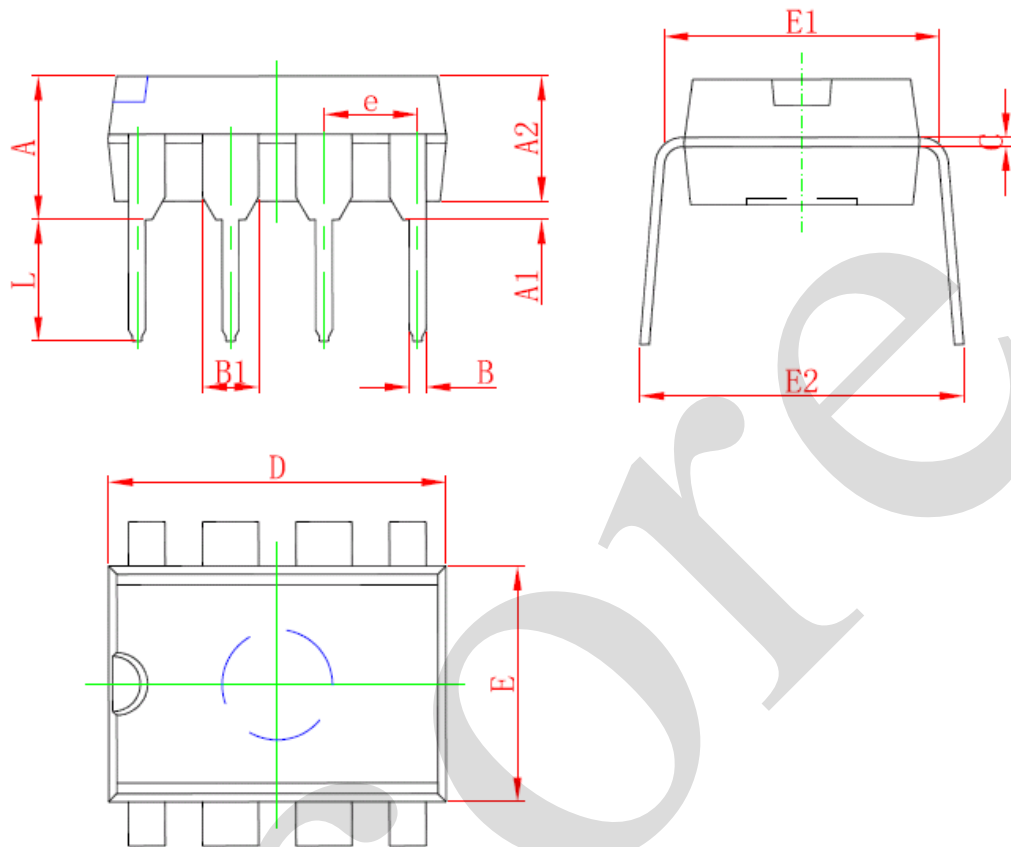

| Symbol | Dimensions In Millimeters | | Dimensions In Inches | |
|--------|---------------------------|-------|----------------------|-------|
| | Min | Max | Min | Max |
| A | 3.710 | 4.310 | 0.146 | 0.170 |
| A1 | 0.510 | | 0.020 | |
| A2 | 3.200 | 3.600 | 0.126 | 0.142 |
| B | 0.380 | 0.570 | 0.015 | 0.022 |
| B1 | 1.524 (BSC) | | 0.060 (BSC) | |
| C | 0.204 | 0.360 | 0.008 | 0.014 |
| D | 9.000 | 9.400 | 0.354 | 0.370 |
| E | 6.200 | 6.600 | 0.244 | 0.260 |
| E1 | 7.320 | 7.920 | 0.288 | 0.312 |
| e | 2.540 (BSC) | | 0.100 (BSC) | |
| L | 3.000 | 3.600 | 0.118 | 0.142 |
| E2 | 8.400 | 9.000 | 0.331 | 0.354 |



5.2、SOP8

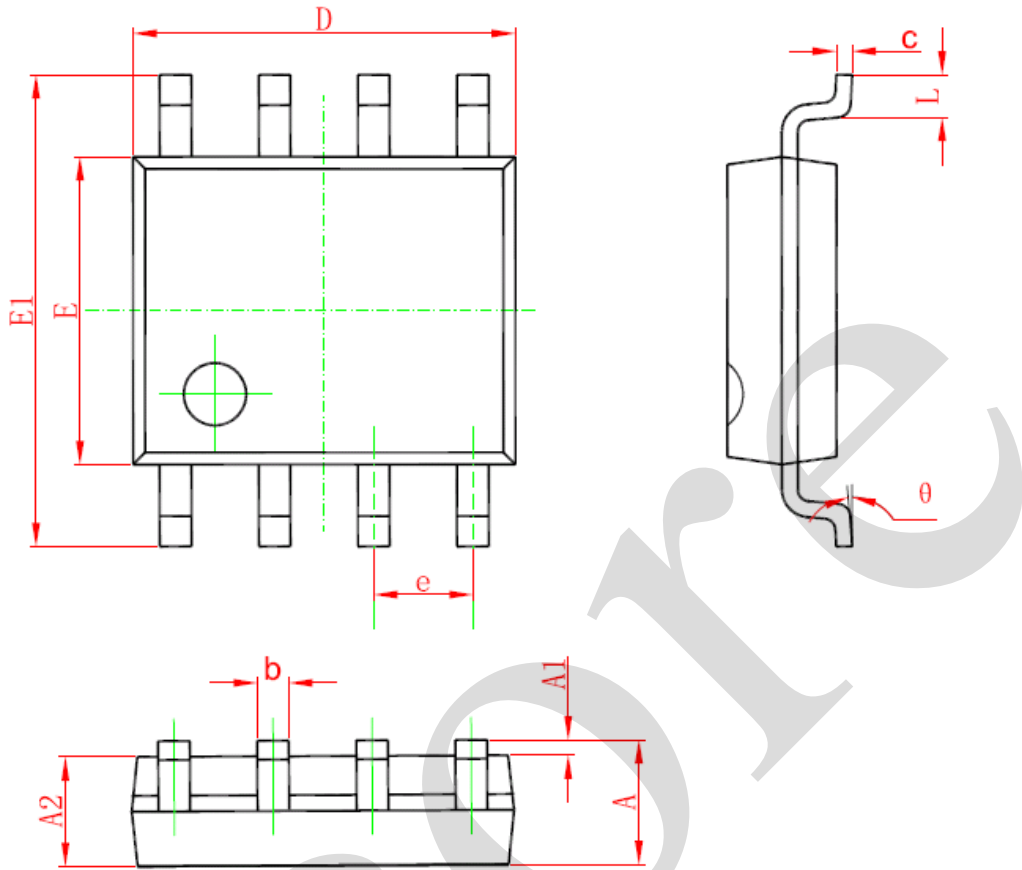

| Symbol | Dimensions In Millimeters | | Dimensions In Inches | |
|--------|---------------------------|-------|----------------------|-------|
| | Min | Max | Min | Max |
| A | 1.350 | 1.750 | 0.053 | 0.069 |
| A1 | 0.100 | 0.250 | 0.004 | 0.010 |
| A2 | 1.350 | 1.550 | 0.053 | 0.061 |
| b | 0.330 | 0.510 | 0.013 | 0.020 |
| c | 0.170 | 0.250 | 0.006 | 0.010 |
| D | 4.700 | 5.100 | 0.185 | 0.200 |
| E | 3.800 | 4.000 | 0.150 | 0.157 |
| E1 | 5.800 | 6.200 | 0.228 | 0.244 |
| e | 1.270 (BSC) | | 0.050 (BSC) | |
| L | 0.400 | 1.270 | 0.016 | 0.050 |
| θ | 0° | 8° | 0° | 8° |



6、 Statements And Notes:

6.1、 The name and content of Hazardous substances or Elements in the product

| Part name | Hazardous substances or Elements | | | | | | | | | |
|-------------------------|---|-------------------------------|-------------------------------|-------------------------------|--------------------------|--------------------------------|-------------------|-----------------------|---------------------------|----------------------|
| | Lead and lead compounds | Mercury and mercury compounds | Cadmium and cadmium compounds | Hexavalent chromium compounds | Polybrominated biphenyls | Polybrominated biphenyl ethers | Dibutyl phthalate | Butylbenzyl phthalate | Di-2-ethylhexyl phthalate | Diisobutyl phthalate |
| Lead frame | ○ | ○ | ○ | ○ | ○ | ○ | ○ | ○ | ○ | ○ |
| Plastic resin | ○ | ○ | ○ | ○ | ○ | ○ | ○ | ○ | ○ | ○ |
| Chip | ○ | ○ | ○ | ○ | ○ | ○ | ○ | ○ | ○ | ○ |
| The lead | ○ | ○ | ○ | ○ | ○ | ○ | ○ | ○ | ○ | ○ |
| Plastic sheet installed | ○ | ○ | ○ | ○ | ○ | ○ | ○ | ○ | ○ | ○ |
| explanation | ○: Indicates that the content of hazardous substances or elements in the detection limit of the following the SJ/T11363-2006 standard. ×: Indicates that the content of hazardous substances or elements exceeding the SJ/T11363-2006 Standard limit requirements. | | | | | | | | | |

6.2、 Notion:

Recommended carefully reading this information before the use of this product;

The information in this document are subject to change without notice;

This information is using to the reference only, the company is not responsible for any loss;

The company is not responsible for the any infringement of the third party patents or other rights of the responsibility.

X-ON Electronics

Largest Supplier of Electrical and Electronic Components

Click to view similar products for [Switching Voltage Regulators](#) category:

Click to view products by [I-core](#) manufacturer:

Other Similar products are found below :

[FAN53610AUC33X](#) [FAN53611AUC123X](#) [EN6310QA](#) [160215](#) [R3](#) [KE177614](#) [FAN53611AUC12X](#) [MAX809TTR](#) [NCV891234MW50R2G](#)
[AST1S31PUR](#) [NCP81203PMNTXG](#) [NCP81208MNTXG](#) [PCA9412AUKZ](#) [NCP81109GMNTXG](#) [NCP3235MNTXG](#) [NCP81109JMNTXG](#)
[NCP81241MNTXG](#) [NTE7223](#) [NTE7222](#) [NTE7224](#) [L6986FTR](#) [MPQ4481GU-AEC1-P](#) [MP8756GD-P](#) [MPQ2171GJ-P](#) [MPQ2171GJ-AEC1-P](#)
[N JW4153U2-A-TE2](#) [MP2171GJ-P](#) [MP28160GC-Z](#) [MPM3509GQVE-AEC1-P](#) [XDPE132G5CG000XUMA1](#) [LM60440AQRPKRQ1](#)
[MP5461GC-P](#) [IW673-20](#) [MPQ4409GQBE-AEC1-P](#) [S-19903DA-A8T1U7](#) [S-19903CA-A6T8U7](#) [S-19903CA-S8T1U7](#) [S-19902BA-A6T8U7](#)
[S-19902CA-A6T8U7](#) [S-19902AA-A6T8U7](#) [S-19903AA-A6T8U7](#) [S-19902AA-S8T1U7](#) [S-19902BA-A8T1U7](#) [AU8310](#)
[LMR23615QDRRRQ1](#) [LMR33630APAQRNXRQ1](#) [LMR33630APCQRNXRQ1](#) [LMR36503R5RPER](#) [LMR36503RFRPER](#)
[LMR36503RS3QRPERQ1](#)