



# **AiP74HC/HCT125**

## **Quad Buffer/Line Driver; 3-state**

### **Product Specification**

**Specification Revision History:**

<b>Version</b>	<b>Date</b>	<b>Description</b>
2019-05-A1	2019-05	New



## 1、 General Description

The AiP74HC/HCT125 is a quad buffer/line driver with 3-state outputs controlled by the output enable inputs ( $\overline{nOE}$ ). A HIGH on  $\overline{nOE}$  causes the outputs to assume a high-impedance OFF-state. Inputs include clamp diodes. This enables the use of current limiting resistors to interface inputs to voltages in excess of  $V_{CC}$ .

### Features:

- Input levels:  
For AiP74HC125: CMOS level  
For AiP74HCT125: TTL level
- Specified from  $-40^{\circ}\text{C}$  to  $+85^{\circ}\text{C}$
- Packaging information: DIP14/SOP14/TSSOP14

**Ordering Information:****Tube packing specifications:**

Type number	Packaging form	Marking code	Tube quantity	Boxed tube quantity	Boxed quantity	Packing box number	Packing quantity	Notes
AiP74HC125DA.TB	DIP14	74HC125	25 PCS/tube	40 tube/box	1000 PCS/box	10 box/pack	10000 PCS/pack	Dimensions of plastic enclosure: 19.0mm×6.4mm Pin spacing: 2.54mm
AiP74HCT125DA.TB	DIP14	74HCT125	25 PCS/tube	40 tube/box	1000 PCS/box	10 box/pack	10000 PCS/pack	Dimensions of plastic enclosure: 19.0mm×6.4mm Pin spacing: 2.54mm
AiP74HC125SA.TB	SOP14	74HC125	50 PCS/tube	200 tube/box	10000 PCS/box	5 box/pack	50000 PCS/pack	Dimensions of plastic enclosure: 8.7mm×3.9mm Pin spacing: 1.27mm
AiP74HCT125SA.TB	SOP14	74HCT125	50 PCS/tube	200 tube/box	10000 PCS/box	5 box/pack	50000 PCS/pack	Dimensions of plastic enclosure: 8.7mm×3.9mm Pin spacing: 1.27mm
AiP74HC125TA.TB	TSSOP14	74HC125	94 PCS/tube	200 tube/box	18800 PCS/box	10 box/pack	188000 PCS/pack	Dimensions of plastic enclosure: 5.0mm×4.4mm Pin spacing: 0.65mm
AiP74HCT125TA.TB	TSSOP14	74HCT125	94 PCS/tube	200 tube/box	18800 PCS/box	10 box/pack	188000 PCS/pack	Dimensions of plastic enclosure: 5.0mm×4.4mm Pin spacing: 0.65mm

**Reel packing specifications:**

Type number	Packaging form	Marking code	Reel quantity	Boxed reel quantity	Packing quantity	Notes
AiP74HC125SA.TR	SOP14	74HC125	2500 PCS/reel	5000 PCS/box	40000 PCS/pack	Dimensions of plastic enclosure: 8.7mm×3.9mm Pin spacing: 1.27mm
AiP74HCT125SA.TR	SOP14	74HCT125	2500 PCS/reel	5000 PCS/box	40000 PCS/pack	Dimensions of plastic enclosure: 8.7mm×3.9mm Pin spacing: 1.27mm
AiP74HC125TA.TR	TSSOP14	74HC125	3000 PCS/reel	6000 PCS/box	48000 PCS/pack	Dimensions of plastic enclosure: 5.0mm×4.4mm Pin spacing: 0.65mm
AiP74HCT125TA.TR	TSSOP14	74HCT125	3000 PCS/reel	6000 PCS/box	48000 PCS/pack	Dimensions of plastic enclosure: 5.0mm×4.4mm Pin spacing: 0.65mm

Note: If the physical information is inconsistent with the ordering information, please refer to the actual product.



## 2、Block Diagram And Pin Description

### 2.1、Block Diagram

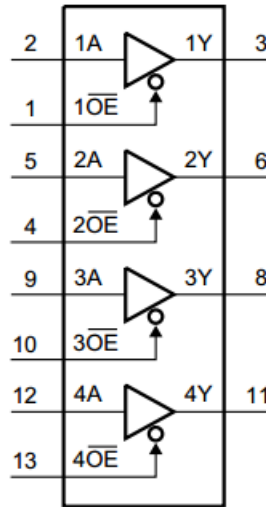

Figure 1. Logic symbol

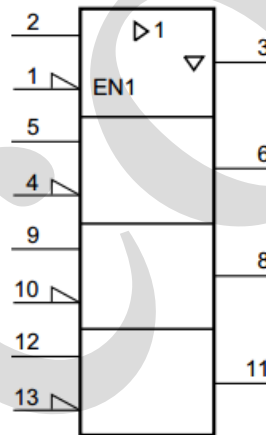

Figure 2. IEC logic symbol

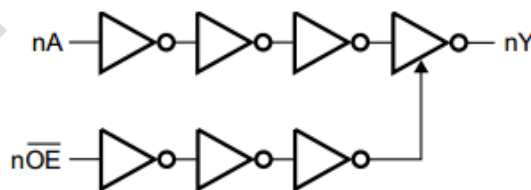
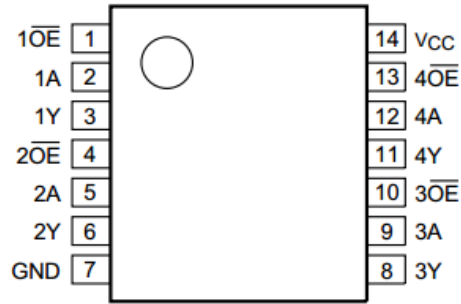

Figure 3. Logic diagram for one gate



## 2.2、Pin Configurations



## 2.3、Pin Description

Pin No.	Pin Name	Description
1	1OE	output enable input (active LOW)
2	1A	data input
3	1Y	data output
4	2OE	output enable input (active LOW)
5	2A	data input
6	2Y	data output
7	GND	ground (0V)
8	3Y	data output
9	3A	data input
10	3OE	output enable input (active LOW)
11	4Y	data output
12	4A	data input
13	4OE	output enable input (active LOW)
14	V <sub>CC</sub>	supply voltage

## 2.4、Function Table

Control	Input	Output
nOE	nA	nY
L	L	L
L	H	H
H	X	Z

Note: H=HIGH voltage level; L=LOW voltage level; X=don't care; Z=high-impedance OFF-state.



## 3、Electrical Parameter

### 3.1、Absolute Maximum Ratings

(Voltages are referenced to GND(ground=0V), unless otherwise specified.)

Parameter	Symbol	Conditions	Min.	Max.	Unit
supply voltage	$V_{CC}$	-	-0.5	+7	V
input clamping current	$I_{IK}$	$V_I < -0.5V$ or $V_I > V_{CC}+0.5V$	-	$\pm 20$	mA
output clamping current	$I_{OK}$	$V_O < -0.5V$ or $V_O > V_{CC}+0.5V$	-	$\pm 20$	mA
output current	$I_O$	$-0.5V < V_O < V_{CC}+0.5V$	-	$\pm 35$	mA
supply current	$I_{CC}$	-	-	70	mA
ground current	$I_{GND}$	-	-70	-	mA
total power dissipation	$P_{tot}$	-	-	500	mW
storage temperature	$T_{stg}$	-	-65	+150	°C
Soldering temperature	$T_L$	10s	DIP	245	°C
			SOP	250	

Note:

[1] For DIP14 packages: above 70°C the value of  $P_{tot}$  derates linearly with 12mW/K.

[2] For SOP14 packages: above 70°C the value of  $P_{tot}$  derates linearly with 8mW/K.

[3] For (T)SSOP14 packages: above 60°C the value of  $P_{tot}$  derates linearly with 5.5mW/K.

### 3.2、Recommended Operating Conditions

Parameter	Symbol	Conditions	Min.	Typ.	Max.	Unit
AiP74HC125						
supply voltage	$V_{CC}$	-	2.0	5.0	6.0	V
input voltage	$V_I$	-	0	-	$V_{CC}$	V
output voltage	$V_O$	-	0	-	$V_{CC}$	V
input transition rise and fall rate	$\Delta t/\Delta V$	$V_{CC}=2.0V$	-	-	625	ns/V
		$V_{CC}=4.5V$	-	1.67	139	ns/V
		$V_{CC}=6.0V$	-	-	83	ns/V
ambient temperature	$T_{amb}$	-	-40	-	+85	°C
AiP74HCT125						
supply voltage	$V_{CC}$	-	4.5	5.0	5.5	V
input voltage	$V_I$	-	0	-	$V_{CC}$	V
output voltage	$V_O$	-	0	-	$V_{CC}$	V
input transition rise and fall rate	$\Delta t/\Delta V$	$V_{CC}=2.0V$	-	-	-	ns/V
		$V_{CC}=4.5V$	-	1.67	139	ns/V
		$V_{CC}=6.0V$	-	-	-	ns/V
ambient temperature	$T_{amb}$	-	-40	-	+85	°C



### 3.3、Electrical Characteristics

#### 3.3.1、DC Characteristics 1

( $T_{amb}=25^{\circ}\text{C}$ , voltages are referenced to GND (ground=0V), unless otherwise specified.)

Parameter	Symbol	Conditions	Min.	Typ.	Max.	Unit	
<b>AiP74HC125</b>							
HIGH-level input voltage	$V_{IH}$	$V_{CC}=2.0\text{V}$	1.5	1.2	-	V	
		$V_{CC}=4.5\text{V}$	3.15	2.4	-	V	
		$V_{CC}=6.0\text{V}$	4.2	3.2	-	V	
LOW-level input voltage	$V_{IL}$	$V_{CC}=2.0\text{V}$	-	0.8	0.5	V	
		$V_{CC}=4.5\text{V}$	-	2.1	1.35	V	
		$V_{CC}=6.0\text{V}$	-	2.8	1.8	V	
HIGH-level output voltage	$V_{OH}$	$V_I = V_{IH} \text{ or } V_{IL}$	$I_O=-20\mu\text{A}; V_{CC}=2.0\text{V}$	1.9	2.0	-	V
			$I_O=-20\mu\text{A}; V_{CC}=4.5\text{V}$	4.4	4.5	-	V
			$I_O=-20\mu\text{A}; V_{CC}=6.0\text{V}$	5.9	6.0	-	V
			$I_O=-6.0\text{mA}; V_{CC}=4.5\text{V}$	3.98	4.32	-	V
			$I_O=-7.8\text{mA}; V_{CC}=6.0\text{V}$	5.48	5.81	-	V
LOW-level output voltage	$V_{OL}$	$V_I = V_{IH} \text{ or } V_{IL}$	$I_O=20\mu\text{A}; V_{CC}=2.0\text{V}$	-	0	0.1	V
			$I_O=20\mu\text{A}; V_{CC}=4.5\text{V}$	-	0	0.1	V
			$I_O=20\mu\text{A}; V_{CC}=6.0\text{V}$	-	0	0.1	V
			$I_O=6.0\text{mA}; V_{CC}=4.5\text{V}$	-	0.15	0.26	V
			$I_O=7.8\text{mA}; V_{CC}=6.0\text{V}$	-	0.16	0.26	V
input leakage current	$I_I$	$V_I = V_{CC} \text{ or } \text{GND}; V_{CC}=6.0\text{V}$	-	-	$\pm 0.1$	$\mu\text{A}$	
OFF-state output current	$I_{OZ}$	$V_I = V_{IH} \text{ or } V_{IL}; V_O = V_{CC} \text{ or } \text{GND}; V_{CC}=6.0\text{V}$	-	-	$\pm 0.5$	$\mu\text{A}$	
supply current	$I_{CC}$	$V_I = V_{CC} \text{ or } \text{GND}; I_O=0\text{A}; V_{CC}=6.0\text{V}$	-	-	2.0	$\mu\text{A}$	
input capacitance	$C_I$	-	-	3.5	-	pF	
<b>AiP74HCT125</b>							
HIGH-level input voltage	$V_{IH}$	$V_{CC}=4.5\text{V to } 5.5\text{V}$	2.0	1.6	-	V	
LOW-level input voltage	$V_{IL}$	$V_{CC}=4.5\text{V to } 5.5\text{V}$	-	1.2	0.8	V	
HIGH-level output voltage	$V_{OH}$	$V_I = V_{IH} \text{ or } V_{IL}$	$I_O=-20\mu\text{A}; V_{CC}=4.5\text{V}$	4.4	4.5	-	V
			$I_O=-6.0\text{mA}; V_{CC}=4.5\text{V}$	3.98	4.32	-	V
LOW-level output voltage	$V_{OL}$	$V_I = V_{IH} \text{ or } V_{IL}$	$I_O=20\mu\text{A}; V_{CC}=4.5\text{V}$	-	0	0.1	V
			$I_O=6.0\text{mA}; V_{CC}=4.5\text{V}$	-	0.16	0.26	V
input leakage current	$I_I$	$V_I = V_{CC} \text{ or } \text{GND}; V_{CC}=5.5\text{V}$	-	-	$\pm 0.1$	$\mu\text{A}$	
OFF-state output current	$I_{OZ}$	$V_I = V_{IH} \text{ or } V_{IL}; V_O = V_{CC} \text{ or } \text{GND}; V_{CC}=5.5\text{V}$	-	-	$\pm 0.5$	$\mu\text{A}$	
supply current	$I_{CC}$	$V_I = V_{CC} \text{ or } \text{GND}; I_O=0\text{A}; V_{CC}=5.5\text{V}$	-	-	8.0	$\mu\text{A}$	
additional supply current	$\Delta I_{CC}$	per input pin; $V_I = V_{CC}-2.1\text{V}; I_O=0\text{A};$ other inputs at $V_{CC} \text{ or } \text{GND}; V_{CC}=4.5\text{V to } 5.5\text{V}$	-	100	360	$\mu\text{A}$	
input capacitance	$C_I$	-	-	3.5	-	pF	





### 3.3.2、DC Characteristics 2

( $T_{amb} = -40^{\circ}\text{C}$  to  $+85^{\circ}\text{C}$ , voltages are referenced to GND (ground=0V), unless otherwise specified.)

Parameter	Symbol	Conditions	Min.	Typ.	Max.	Unit	
AiP74HC125							
HIGH-level input voltage	$V_{IH}$	$V_{CC}=2.0\text{V}$	1.5	-	-	V	
		$V_{CC}=4.5\text{V}$	3.15	-	-	V	
		$V_{CC}=6.0\text{V}$	4.2	-	-	V	
LOW-level input voltage	$V_{IL}$	$V_{CC}=2.0\text{V}$	-	-	0.5	V	
		$V_{CC}=4.5\text{V}$	-	-	1.35	V	
		$V_{CC}=6.0\text{V}$	-	-	1.8	V	
HIGH-level output voltage	$V_{OH}$	$V_I = V_{IH} \text{ or } V_{IL}$	$I_O=-20\mu\text{A}; V_{CC}=2.0\text{V}$	1.9	-	-	V
			$I_O=-20\mu\text{A}; V_{CC}=4.5\text{V}$	4.4	-	-	V
			$I_O=-20\mu\text{A}; V_{CC}=6.0\text{V}$	5.9	-	-	V
			$I_O=-6.0\text{mA}; V_{CC}=4.5\text{V}$	3.84	-	-	V
			$I_O=-7.8\text{mA}; V_{CC}=6.0\text{V}$	5.34	-	-	V
LOW-level output voltage	$V_{OL}$	$V_I = V_{IH} \text{ or } V_{IL}$	$I_O=20\mu\text{A}; V_{CC}=2.0\text{V}$	-	-	0.1	V
			$I_O=20\mu\text{A}; V_{CC}=4.5\text{V}$	-	-	0.1	V
			$I_O=20\mu\text{A}; V_{CC}=6.0\text{V}$	-	-	0.1	V
			$I_O=6.0\text{mA}; V_{CC}=4.5\text{V}$	-	-	0.33	V
			$I_O=7.8\text{mA}; V_{CC}=6.0\text{V}$	-	-	0.33	V
input leakage current	$I_I$	$V_I = V_{CC} \text{ or } \text{GND}; V_{CC}=6.0\text{V}$	-	-	$\pm 1$	$\mu\text{A}$	
OFF-state output current	$I_{OZ}$	$V_I = V_{IH} \text{ or } V_{IL}; V_O = V_{CC} \text{ or } \text{GND}; V_{CC}=6.0\text{V}$	-	-	$\pm 5$	$\mu\text{A}$	
supply current	$I_{CC}$	$V_I = V_{CC} \text{ or } \text{GND}; I_O=0\text{A}; V_{CC}=6.0\text{V}$	-	-	80	$\mu\text{A}$	
input capacitance	$C_I$	-	-	-	-	pF	
AiP74HCT125							
HIGH-level input voltage	$V_{IH}$	$V_{CC}=4.5\text{V to } 5.5\text{V}$	2.0	-	-	V	
LOW-level input voltage	$V_{IL}$	$V_{CC}=4.5\text{V to } 5.5\text{V}$	-	-	0.8	V	
HIGH-level output voltage	$V_{OH}$	$V_I = V_{IH} \text{ or } V_{IL}$	$I_O=-20\mu\text{A}; V_{CC}=4.5\text{V}$	4.4	-	-	V
			$I_O=-6.0\text{mA}; V_{CC}=4.5\text{V}$	3.84	-	-	V
LOW-level output voltage	$V_{OL}$	$V_I = V_{IH} \text{ or } V_{IL}$	$I_O=20\mu\text{A}; V_{CC}=4.5\text{V}$	-	-	0.1	V
			$I_O=6.0\text{mA}; V_{CC}=4.5\text{V}$	-	-	0.33	V
input leakage current	$I_I$	$V_I = V_{CC} \text{ or } \text{GND}; V_{CC}=5.5\text{V}$	-	-	$\pm 1$	$\mu\text{A}$	
OFF-state output current	$I_{OZ}$	$V_I = V_{IH} \text{ or } V_{IL}; V_O = V_{CC} \text{ or } \text{GND}; V_{CC}=5.5\text{V}$	-	-	$\pm 5$	$\mu\text{A}$	
supply current	$I_{CC}$	$V_I = V_{CC} \text{ or } \text{GND}; I_O=0\text{A}; V_{CC}=5.5\text{V}$	-	-	80	$\mu\text{A}$	
additional supply current	$\Delta I_{CC}$	per input pin; $V_I = V_{CC} - 2.1\text{V}; I_O=0\text{A};$ other inputs at $V_{CC} \text{ or } \text{GND}; V_{CC}=4.5\text{V to } 5.5\text{V}$	-	-	450	$\mu\text{A}$	
input capacitance	$C_I$	-	-	-	-	pF	



### 3.3.3、 AC Characteristics 1

( $T_{amb}=25^{\circ}C$ , voltages are referenced to GND (ground=0V), unless otherwise specified.)

Parameter	Symbol	Conditions	Min.	Typ.	Max.	Unit	
<b>AiP74HC125</b>							
nA to nY propagation delay	$t_{pd}$	see Figure 5	$V_{CC}=2.0V$	-	30	100	ns
			$V_{CC}=4.5V$	-	11	20	ns
			$V_{CC}=5.0V; C_L=15pF$	-	9	-	ns
			$V_{CC}=6.0V$	-	9	17	ns
nOE to nY enable time	$t_{en}$	see Figure 6	$V_{CC}=2.0V$	-	41	125	ns
			$V_{CC}=4.5V$	-	15	25	ns
			$V_{CC}=6.0V$	-	12	21	ns
nOE to nY disable time	$t_{dis}$	see Figure 6	$V_{CC}=2.0V$	-	41	125	ns
			$V_{CC}=4.5V$	-	15	25	ns
			$V_{CC}=6.0V$	-	12	21	ns
transition time	$t_t$	see Figure 5	$V_{CC}=2.0V$	-	14	60	ns
			$V_{CC}=4.5V$	-	5	12	ns
			$V_{CC}=6.0V$	-	4	10	ns
power dissipation capacitance	$C_{PD}$	$C_L=50pF; f=1MHz; V_I=GND \text{ to } V_{CC}$	-	22	-	pF	
<b>AiP74HCT125</b>							
nA to nY propagation delay	$t_{pd}$	see Figure 5	$V_{CC}=4.5V$	-	15	25	ns
			$V_{CC}=5.0V; C_L=15pF$	-	12	-	ns
nOE to nY enable time	$t_{en}$	see Figure 6	$V_{CC}=4.5V$	-	15	28	ns
nOE to nY disable time	$t_{dis}$	see Figure 6	$V_{CC}=4.5V$	-	15	25	ns
transition time	$t_t$	see Figure 5	$V_{CC}=4.5V$	-	5	12	ns
power dissipation capacitance	$C_{PD}$	$C_L=50pF; f=1MHz; V_I=GND \text{ to } V_{CC}-1.5V$	-	24	-	pF	

Note:

- [1]  $t_{pd}$  is the same as  $t_{PLH}$  and  $t_{PHL}$ .
- [2]  $t_{en}$  is the same as  $t_{pZL}$  and  $t_{pZH}$ .
- [3]  $t_{dis}$  is the same as  $t_{pLZ}$  and  $t_{pHZ}$ .
- [4]  $t_t$  is the same as  $t_{THL}$  and  $t_{TLH}$ .
- [5]  $C_{PD}$  is used to determine the dynamic power dissipation ( $P_D$  in uW).

$$P_D = (C_{PD} \times V_{CC}^2 \times f_i \times N) + \sum (C_L \times V_{CC}^2 \times f_o) \text{ where:}$$

$f_i$ =input frequency in MHz;

$f_o$ =output frequency in MHz;

$C_L$ =output load capacitance in pF;

$V_{CC}$ =supply voltage in V;

$N$ =number of inputs switching;

$\sum (C_L \times V_{CC}^2 \times f_o)$ =sum of outputs.



### 3.3.4、AC Characteristics 2

( $T_{amb} = -40^{\circ}\text{C}$  to  $+85^{\circ}\text{C}$ , voltages are referenced to GND (ground=0V), unless otherwise specified.)

Parameter	Symbol	Conditions	Min.	Typ.	Max.	Unit	
AiP74HC125							
nA to nY propagation delay	$t_{pd}$	see Figure 5	$V_{CC}=2.0\text{V}$	-	-	125	ns
			$V_{CC}=4.5\text{V}$	-	-	25	ns
			$V_{CC}=5.0\text{V}; C_L=15\text{pF}$	-	-	-	ns
			$V_{CC}=6.0\text{V}$	-	-	21	ns
nOE to nY enable time	$t_{en}$	see Figure 6	$V_{CC}=2.0\text{V}$	-	-	155	ns
			$V_{CC}=4.5\text{V}$	-	-	31	ns
			$V_{CC}=6.0\text{V}$	-	-	26	ns
nOE to nY disable time	$t_{dis}$	see Figure 6	$V_{CC}=2.0\text{V}$	-	-	155	ns
			$V_{CC}=4.5\text{V}$	-	-	31	ns
			$V_{CC}=6.0\text{V}$	-	-	26	ns
transition time	$t_t$	see Figure 5	$V_{CC}=2.0\text{V}$	-	-	75	ns
			$V_{CC}=4.5\text{V}$	-	-	15	ns
			$V_{CC}=6.0\text{V}$	-	-	13	ns
power dissipation capacitance	$C_{PD}$	$C_L=50\text{pF}; f=1\text{MHz}; V_I=\text{GND to } V_{CC}$	-	-	-	pF	
AiP74HCT125							
nA to nY propagation delay	$t_{pd}$	see Figure 5	$V_{CC}=4.5\text{V}$	-	-	31	ns
			$V_{CC}=5.0\text{V}; C_L=15\text{pF}$	-	-	-	ns
nOE to nY enable time	$t_{en}$	see Figure 6	$V_{CC}=4.5\text{V}$	-	-	35	ns
nOE to nY disable time	$t_{dis}$	see Figure 6	$V_{CC}=4.5\text{V}$	-	-	31	ns
transition time	$t_t$	see Figure 5	$V_{CC}=4.5\text{V}$	-	-	15	ns
power dissipation capacitance	$C_{PD}$	$C_L=50\text{pF}; f=1\text{MHz}; V_I=\text{GND to } V_{CC}-1.5\text{V}$	-	-	-	pF	

Note:

[1]  $t_{pd}$  is the same as  $t_{PLH}$  and  $t_{PHL}$ .

[2]  $t_{en}$  is the same as  $t_{PZL}$  and  $t_{PZH}$ .

[3]  $t_{dis}$  is the same as  $t_{PLZ}$  and  $t_{PHZ}$ .

[4]  $t_t$  is the same as  $t_{THL}$  and  $t_{TLH}$ .

[5]  $C_{PD}$  is used to determine the dynamic power dissipation ( $P_D$  in  $\mu\text{W}$ ).

$$P_D = (C_{PD} \times V_{CC}^2 \times f_i \times N) + \sum (C_L \times V_{CC}^2 \times f_o) \text{ where:}$$

$f_i$  = input frequency in MHz;

$f_o$  = output frequency in MHz;

$C_L$  = output load capacitance in pF;

$V_{CC}$  = supply voltage in V;

$N$  = number of inputs switching;

$\sum (C_L \times V_{CC}^2 \times f_o)$  = sum of outputs.



## 4、 Testing Circuit

### 4.1、 AC Testing Circuit

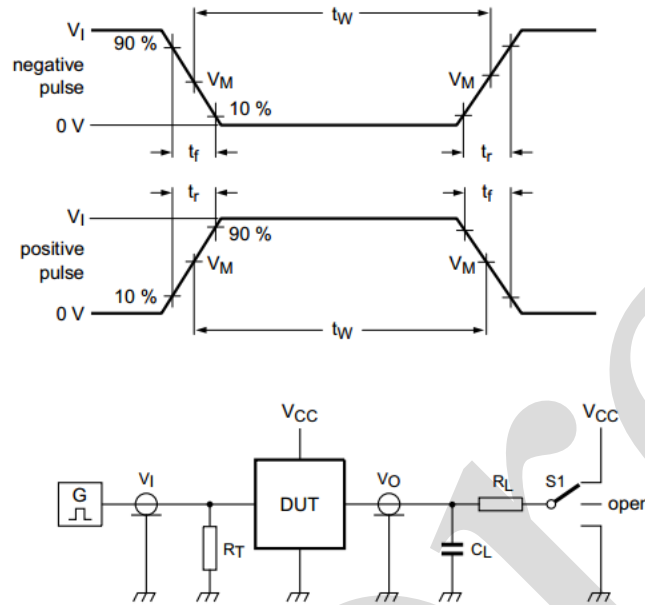

Figure 4. Test circuit for measuring switching times

Definitions for test circuit:

$C_L$ =load capacitance including jig and probe capacitance.

$R_T$ =termination resistance should be equal to the output impedance  $Z_o$  of the pulse generator.

$R_L$ = Load resistance.

S1 = Test selection switch.

### 4.2、 AC Testing Waveforms

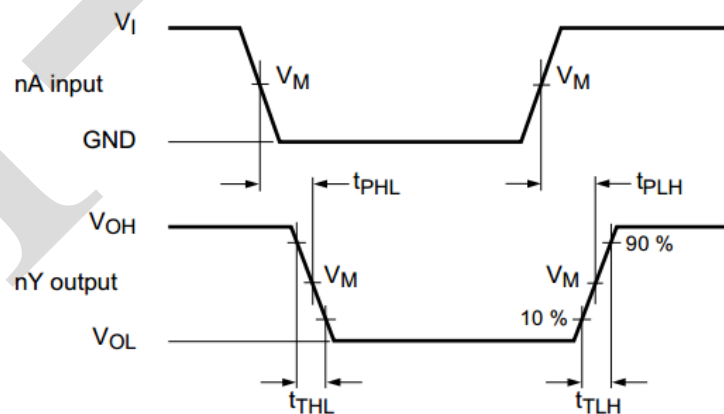

Figure 5. Propagation delay input (nA) to output (nY)

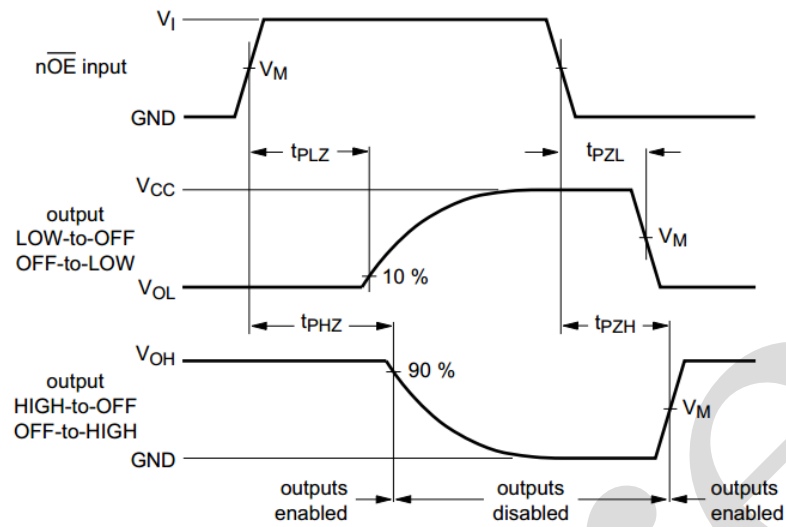

Figure 6. Enable and disable times

### 4.3、 Measurement Points

Type	Input	Output
	$V_M$	$V_M$
AiP74HC125	$0.5 \times V_{CC}$	$0.5 \times V_{CC}$
AiP74HCT125	1.3V	1.3V

### 4.4、 Test Data

Type	Input		Load		S1 position		
	$V_I$	$t_r, t_f$	$C_L$	$R_L$	$t_{PHL}, t_{PLH}$	$t_{PZH}, t_{PHZ}$	$t_{PZL}, t_{PLZ}$
AiP74HC125	$V_{CC}$	6.0ns	15pF, 50pF	1k $\Omega$	open	GND	$V_{CC}$
AiP74HCT125	3V	6.0ns	15pF, 50pF	1k $\Omega$	open	GND	$V_{CC}$



## 5、Package Information

### 5.1、DIP14

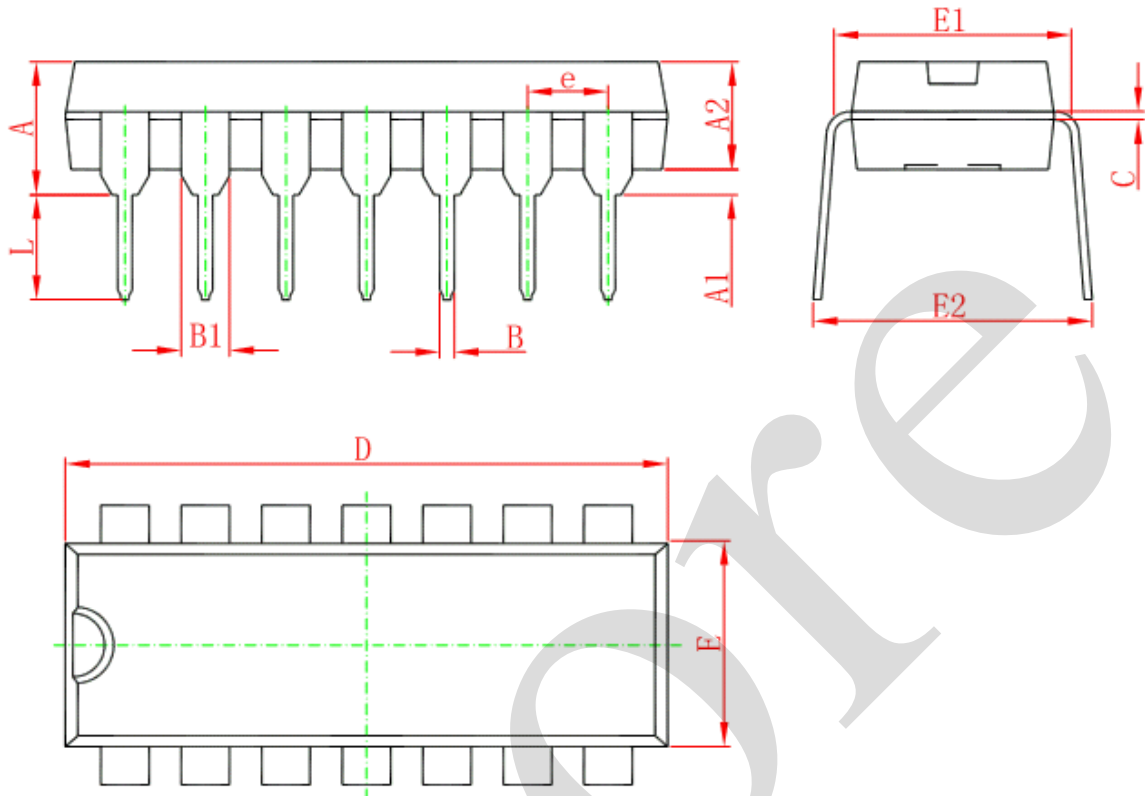

Symbol	Dimensions In Millimeters		Dimensions In Inches	
	Min	Max	Min	Max
A	3.710	4.310	0.146	0.170
A1	0.510		0.020	
A2	3.200	3.600	0.126	0.142
B	0.380	0.570	0.015	0.022
B1	1.524 (BSC)		0.060 (BSC)	
C	0.204	0.360	0.008	0.014
D	18.800	19.200	0.740	0.756
E	6.200	6.600	0.244	0.260
E1	7.320	7.920	0.288	0.312
e	2.540 (BSC)		0.100 (BSC)	
L	3.000	3.600	0.118	0.142
E2	8.400	9.000	0.331	0.354



5.2、SOP14

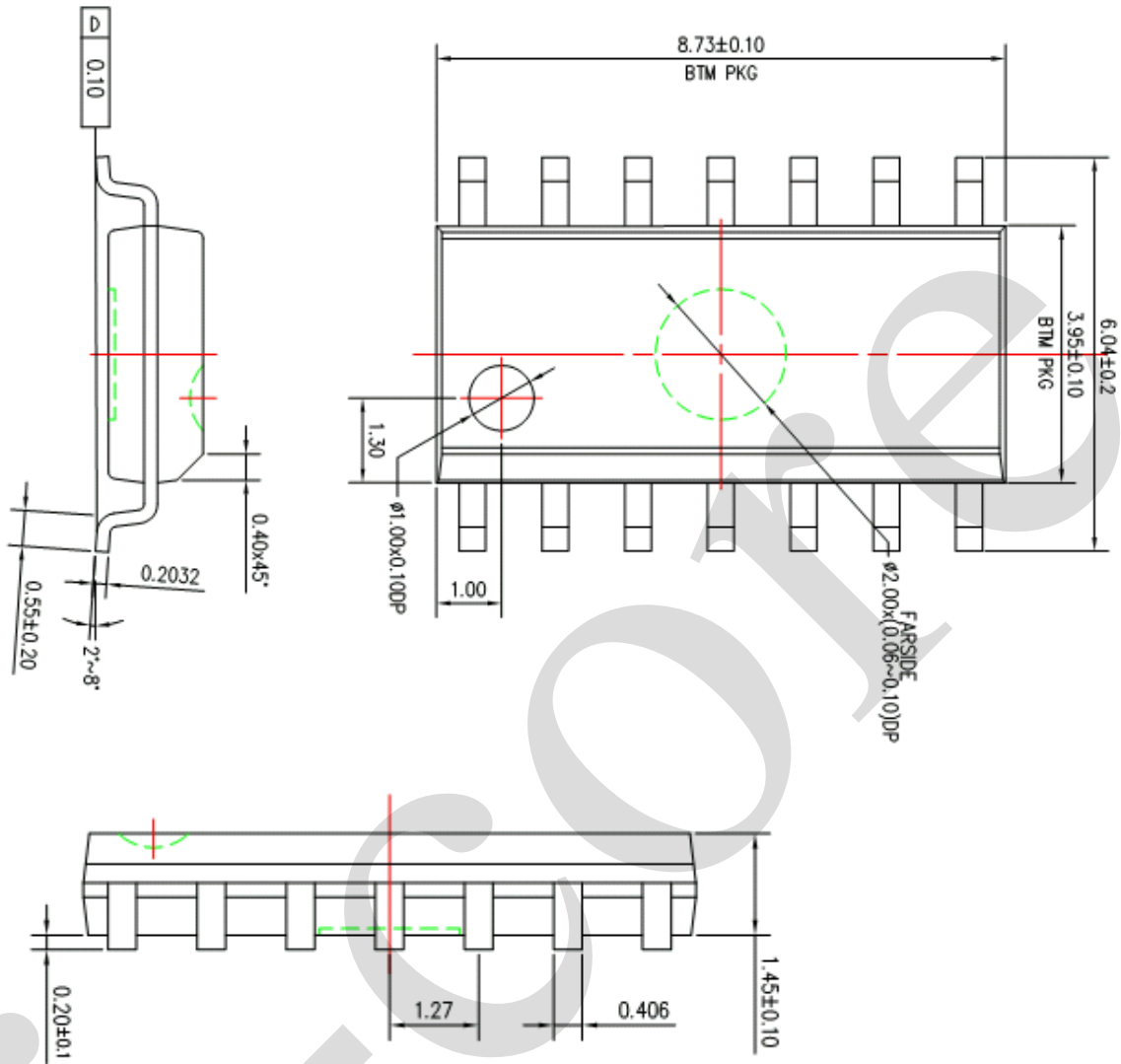



5.3、TSSOP14

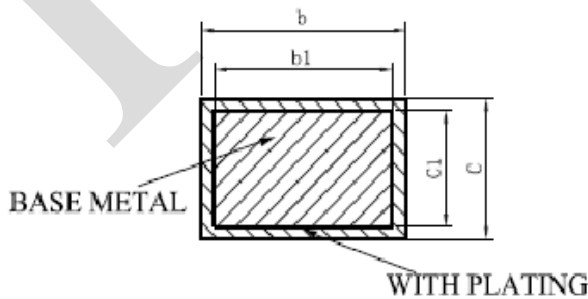
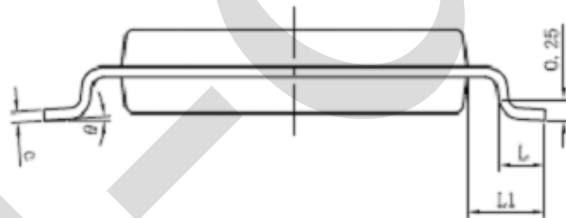
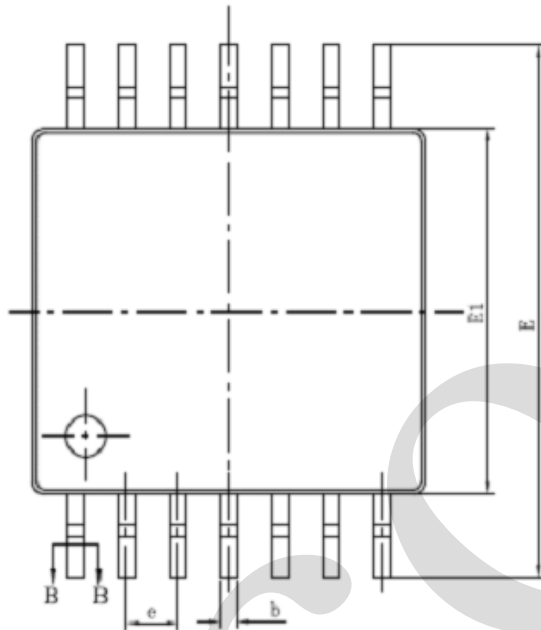
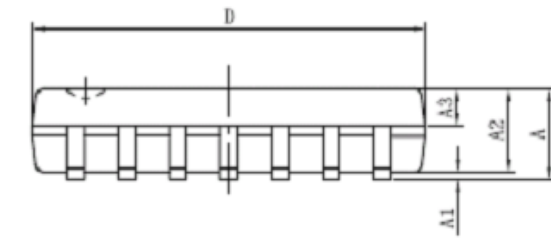

SECTION B-B

SYMBOL	MILLIMETER	
	MIN	MAX
A	—	1.20
A1	0.05	0.15
A2	0.90	1.05
A3	0.39	0.49
b	0.20	0.30
b1	0.19	0.25
c	0.13	0.19
c1	0.12	0.14
D	4.86	5.06
E1	4.30	4.50
E	6.20	6.60
e	0.65BSC	
L	0.45	0.75
L1	1.00BSC	
θ	0	8°





## 6、 Statements And Notes

### 6.1、 The name and content of Hazardous substances or Elements in the product

Part name	Hazardous substances or Elements									
	Lead and lead compounds	Mercury and mercury compounds	Cadmium and cadmium compounds	Hexavalent chromium compounds	Polybrominated biphenyls	Polybrominated biphenyl ethers	Dibutyl phthalate	Butylbenzyl phthalate	Di-2-ethylhexyl phthalate	Diisobutyl phthalate
Lead frame	○	○	○	○	○	○	○	○	○	○
Plastic resin	○	○	○	○	○	○	○	○	○	○
Chip	○	○	○	○	○	○	○	○	○	○
The lead	○	○	○	○	○	○	○	○	○	○
Plastic sheet installed	○	○	○	○	○	○	○	○	○	○
explanation	○: Indicates that the content of hazardous substances or elements in the detection limit of the following the SJ/T11363-2006 standard. ×: Indicates that the content of hazardous substances or elements exceeding the SJ/T11363-2006 Standard limit requirements.									

### 6.2、 Notion

Recommended carefully reading this information before the use of this product;

The information in this document are subject to change without notice;

This information is using to the reference only, the company is not responsible for any loss;

The company is not responsible for the any infringement of the third party patents or other rights of the responsibility.

## X-ON Electronics

Largest Supplier of Electrical and Electronic Components

*Click to view similar products for [Buffers & Line Drivers](#) category:*

*Click to view products by [I-core](#) manufacturer:*

Other Similar products are found below :

[LXV200-024SW](#) [74AUP2G34FW3-7](#) [HEF4043BP](#) [NL17SG125DFT2G](#) [NLU1GT126CMUTCG](#) [CD4041UBE](#) [54FCT240CTDB](#)  
[74HCT540N](#) [DS14C88N](#) [070519XB](#) [NL17SZ07P5T5G](#) [74LVC2G17FW4-7](#) [CD4502BE](#) [5962-8982101PA](#) [61446R00](#) [NL17SH17P5T5G](#)  
[NLV37WZ17USG](#) [74HCT126T14-13](#) [74VHC9126FT\(BJ\)](#) [RHRXH162244K1](#) [74AUP1G34FW5-7](#) [74AUP1G07FW5-7](#) [74LVC1G126FW4-7](#)  
[74LVC2G126RA3-7](#) [74LVCE1G125FZ4-7](#) [54FCT240TLB](#) [NLX3G16DMUTCG](#) [NLX2G06AMUTCG](#) [LE87100NQCT](#) [LE87285NQC](#)  
[LE87290YQC](#) [LE87290YQCT](#) [74AUP1G125FW5-7](#) [NLU2G16CMUTCG](#) [MC74LCX244MN2TWG](#) [NL17SG17P5T5G](#)  
[NLV74HC125ADR2G](#) [NLVHCT245ADTR2G](#) [NLVVHC1G126DFT2G](#) [EL5623IRZ](#) [ISL15102AIRZ-T13](#) [ISL1539IRZ-T13](#)  
[MC100EP17MNG](#) [MC74HCT365ADR2G](#) [MC74LCX244ADTR2G](#) [NL27WZ126US](#) [NL37WZ16US](#) [NLU1G07MUTCG](#) [NLU2G07MUTCG](#)  
[NLX3G17BMX1TCG](#)