



AiP74HC/HCT125

Quad Buffer/Line Driver; 3-state

Product Specification

Specification Revision History:

Version	Date	Description
2019-05-A1	2019-05	New



1、 General Description

The AiP74HC/HCT125 is a quad buffer/line driver with 3-state outputs controlled by the output enable inputs (\overline{nOE}). A HIGH on \overline{nOE} causes the outputs to assume a high-impedance OFF-state. Inputs include clamp diodes. This enables the use of current limiting resistors to interface inputs to voltages in excess of V_{CC} .

Features:

- Input levels:
 - For AiP74HC125: CMOS level
 - For AiP74HCT125: TTL level
- Specified from -40°C to +85°C
- Packaging information: DIP14/SOP14/TSSOP14

**Ordering Information:****Tube packing specifications:**

Type number	Packaging form	Marking code	Tube quantity	Boxed tube quantity	Boxed quantity	Packing box number	Packing quantity	Notes
AiP74HC125DA.TB	DIP14	74HC125	25 PCS/tube	40 tube/box	1000 PCS/box	10 box/pack	10000 PCS/pack	Dimensions of plastic enclosure: 19.0mm×6.4mm Pin spacing: 2.54mm
AiP74HCT125DA.TB	DIP14	74HCT125	25 PCS/tube	40 tube/box	1000 PCS/box	10 box/pack	10000 PCS/pack	Dimensions of plastic enclosure: 19.0mm×6.4mm Pin spacing: 2.54mm
AiP74HC125SA.TB	SOP14	74HC125	50 PCS/tube	200 tube/box	10000 PCS/box	5 box/pack	50000 PCS/pack	Dimensions of plastic enclosure: 8.7mm×3.9mm Pin spacing: 1.27mm
AiP74HCT125SA.TB	SOP14	74HCT125	50 PCS/tube	200 tube/box	10000 PCS/box	5 box/pack	50000 PCS/pack	Dimensions of plastic enclosure: 8.7mm×3.9mm Pin spacing: 1.27mm
AiP74HC125TA.TB	TSSOP14	74HC125	94 PCS/tube	200 tube/box	18800 PCS/box	10 box/pack	188000 PCS/pack	Dimensions of plastic enclosure: 5.0mm×4.4mm Pin spacing: 0.65mm
AiP74HCT125TA.TB	TSSOP14	74HCT125	94 PCS/tube	200 tube/box	18800 PCS/box	10 box/pack	188000 PCS/pack	Dimensions of plastic enclosure: 5.0mm×4.4mm Pin spacing: 0.65mm

**Reel packing specifications:**

Type number	Packaging form	Marking code	Reel quantity	Boxed reel quantity	Packing quantity	Notes
AiP74HC125SA.TR	SOP14	74HC125	2500 PCS/reel	5000 PCS/box	40000 PCS/pack	Dimensions of plastic enclosure: 8.7mm×3.9mm Pin spacing: 1.27mm
AiP74HCT125SA.TR	SOP14	74HCT125	2500 PCS/reel	5000 PCS/box	40000 PCS/pack	Dimensions of plastic enclosure: 8.7mm×3.9mm Pin spacing: 1.27mm
AiP74HC125TA.TR	TSSOP14	74HC125	3000 PCS/reel	6000 PCS/box	48000 PCS/pack	Dimensions of plastic enclosure: 5.0mm×4.4mm Pin spacing: 0.65mm
AiP74HCT125TA.TR	TSSOP14	74HCT125	3000 PCS/reel	6000 PCS/box	48000 PCS/pack	Dimensions of plastic enclosure: 5.0mm×4.4mm Pin spacing: 0.65mm

Note: If the physical information is inconsistent with the ordering information, please refer to the actual product.



2、Block Diagram And Pin Description

2.1、Block Diagram

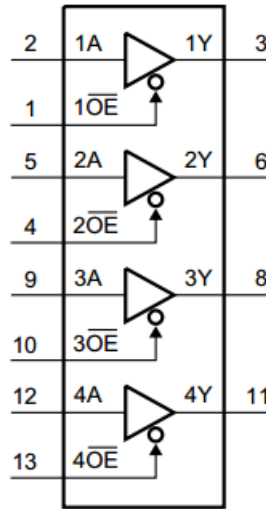

Figure 1. Logic symbol

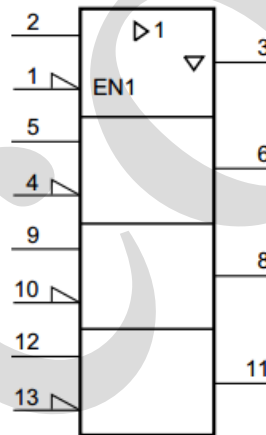

Figure 2. IEC logic symbol

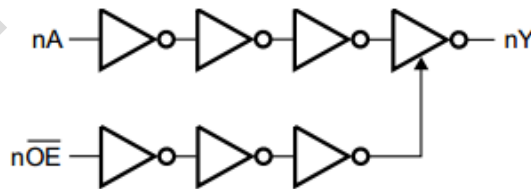
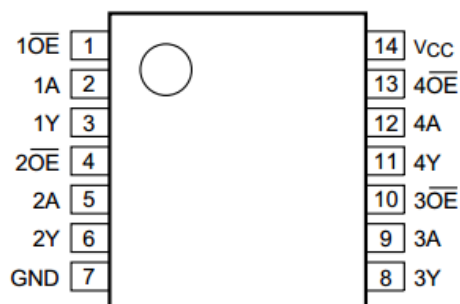

Figure 3. Logic diagram for one gate



2.2、Pin Configurations



2.3、Pin Description

Pin No.	Pin Name	Description
1	1OE	output enable input (active LOW)
2	1A	data input
3	1Y	data output
4	2OE	output enable input (active LOW)
5	2A	data input
6	2Y	data output
7	GND	ground (0V)
8	3Y	data output
9	3A	data input
10	3OE	output enable input (active LOW)
11	4Y	data output
12	4A	data input
13	4OE	output enable input (active LOW)
14	V _{CC}	supply voltage

2.4、Function Table

Control	Input	Output
nOE	nA	nY
L	L	L
L	H	H
H	X	Z

Note: H=HIGH voltage level; L=LOW voltage level; X=don't care; Z=high-impedance OFF-state.



3、Electrical Parameter

3.1、Absolute Maximum Ratings

(Voltages are referenced to GND(ground=0V), unless otherwise specified.)

Parameter	Symbol	Conditions	Min.	Max.	Unit
supply voltage	V_{CC}	-	-0.5	+7	V
input clamping current	I_{IK}	$V_I < -0.5V$ or $V_I > V_{CC}+0.5V$	-	± 20	mA
output clamping current	I_{OK}	$V_O < -0.5V$ or $V_O > V_{CC}+0.5V$	-	± 20	mA
output current	I_O	$-0.5V < V_O < V_{CC}+0.5V$	-	± 35	mA
supply current	I_{CC}	-	-	70	mA
ground current	I_{GND}	-	-70	-	mA
total power dissipation	P_{tot}	-	-	500	mW
storage temperature	T_{stg}	-	-65	+150	°C
Soldering temperature	T_L	10s	DIP	245	°C
			SOP	250	

Note:

[1] For DIP14 packages: above 70°C the value of P_{tot} derates linearly with 12mW/K.

[2] For SOP14 packages: above 70°C the value of P_{tot} derates linearly with 8mW/K.

[3] For (T)SSOP14 packages: above 60°C the value of P_{tot} derates linearly with 5.5mW/K.

3.2、Recommended Operating Conditions

Parameter	Symbol	Conditions	Min.	Typ.	Max.	Unit
AiP74HC125						
supply voltage	V_{CC}	-	2.0	5.0	6.0	V
input voltage	V_I	-	0	-	V_{CC}	V
output voltage	V_O	-	0	-	V_{CC}	V
input transition rise and fall rate	$\Delta t/\Delta V$	$V_{CC}=2.0V$	-	-	625	ns/V
		$V_{CC}=4.5V$	-	1.67	139	ns/V
		$V_{CC}=6.0V$	-	-	83	ns/V
ambient temperature	T_{amb}	-	-40	-	+85	°C
AiP74HCT125						
supply voltage	V_{CC}	-	4.5	5.0	5.5	V
input voltage	V_I	-	0	-	V_{CC}	V
output voltage	V_O	-	0	-	V_{CC}	V
input transition rise and fall rate	$\Delta t/\Delta V$	$V_{CC}=2.0V$	-	-	-	ns/V
		$V_{CC}=4.5V$	-	1.67	139	ns/V
		$V_{CC}=6.0V$	-	-	-	ns/V
ambient temperature	T_{amb}	-	-40	-	+85	°C



3.3、Electrical Characteristics

3.3.1、DC Characteristics 1

($T_{amb}=25^{\circ}C$, voltages are referenced to GND (ground=0V), unless otherwise specified.)

Parameter	Symbol	Conditions	Min.	Typ.	Max.	Unit	
AiP74HC125							
HIGH-level input voltage	V_{IH}	$V_{CC}=2.0V$	1.5	1.2	-	V	
		$V_{CC}=4.5V$	3.15	2.4	-	V	
		$V_{CC}=6.0V$	4.2	3.2	-	V	
LOW-level input voltage	V_{IL}	$V_{CC}=2.0V$	-	0.8	0.5	V	
		$V_{CC}=4.5V$	-	2.1	1.35	V	
		$V_{CC}=6.0V$	-	2.8	1.8	V	
HIGH-level output voltage	V_{OH}	$V_I = V_{IH} \text{ or } V_{IL}$	$I_O=-20\mu A; V_{CC}=2.0V$	1.9	2.0	-	V
			$I_O=-20\mu A; V_{CC}=4.5V$	4.4	4.5	-	V
			$I_O=-20\mu A; V_{CC}=6.0V$	5.9	6.0	-	V
			$I_O=-6.0mA; V_{CC}=4.5V$	3.98	4.32	-	V
			$I_O=-7.8mA; V_{CC}=6.0V$	5.48	5.81	-	V
LOW-level output voltage	V_{OL}	$V_I = V_{IH} \text{ or } V_{IL}$	$I_O=20\mu A; V_{CC}=2.0V$	-	0	0.1	V
			$I_O=20\mu A; V_{CC}=4.5V$	-	0	0.1	V
			$I_O=20\mu A; V_{CC}=6.0V$	-	0	0.1	V
			$I_O=6.0mA; V_{CC}=4.5V$	-	0.15	0.26	V
			$I_O=7.8mA; V_{CC}=6.0V$	-	0.16	0.26	V
input leakage current	I_I	$V_I = V_{CC} \text{ or } GND; V_{CC}=6.0V$	-	-	± 0.1	μA	
OFF-state output current	I_{OZ}	$V_I = V_{IH} \text{ or } V_{IL}; V_O = V_{CC} \text{ or } GND; V_{CC}=6.0V$	-	-	± 0.5	μA	
supply current	I_{CC}	$V_I = V_{CC} \text{ or } GND; I_O=0A; V_{CC}=6.0V$	-	-	8.0	μA	
input capacitance	C_I	-	-	3.5	-	pF	
AiP74HCT125							
HIGH-level input voltage	V_{IH}	$V_{CC}=4.5V \text{ to } 5.5V$	2.0	1.6	-	V	
LOW-level input voltage	V_{IL}	$V_{CC}=4.5V \text{ to } 5.5V$	-	1.2	0.8	V	
HIGH-level output voltage	V_{OH}	$V_I = V_{IH} \text{ or } V_{IL}$	$I_O=-20\mu A; V_{CC}=4.5V$	4.4	4.5	-	V
			$I_O=-6.0mA; V_{CC}=4.5V$	3.98	4.32	-	V
LOW-level output voltage	V_{OL}	$V_I = V_{IH} \text{ or } V_{IL}$	$I_O=20\mu A; V_{CC}=4.5V$	-	0	0.1	V
			$I_O=6.0mA; V_{CC}=4.5V$	-	0.16	0.26	V
input leakage current	I_I	$V_I = V_{CC} \text{ or } GND; V_{CC}=5.5V$	-	-	± 0.1	μA	
OFF-state output current	I_{OZ}	$V_I = V_{IH} \text{ or } V_{IL}; V_O = V_{CC} \text{ or } GND; V_{CC}=5.5V$	-	-	± 0.5	μA	
supply current	I_{CC}	$V_I = V_{CC} \text{ or } GND; I_O=0A; V_{CC}=5.5V$	-	-	8.0	μA	
additional supply current	ΔI_{CC}	per input pin; $V_I = V_{CC}-2.1V; I_O=0A$; other inputs at $V_{CC} \text{ or } GND; V_{CC}=4.5V \text{ to } 5.5V$	-	100	360	μA	
input capacitance	C_I	-	-	3.5	-	pF	



3.3.2、DC Characteristics 2

($T_{amb} = -40^{\circ}\text{C}$ to $+85^{\circ}\text{C}$, voltages are referenced to GND (ground=0V), unless otherwise specified.)

Parameter	Symbol	Conditions	Min.	Typ.	Max.	Unit	
AiP74HC125							
HIGH-level input voltage	V_{IH}	$V_{CC}=2.0\text{V}$	1.5	-	-	V	
		$V_{CC}=4.5\text{V}$	3.15	-	-	V	
		$V_{CC}=6.0\text{V}$	4.2	-	-	V	
LOW-level input voltage	V_{IL}	$V_{CC}=2.0\text{V}$	-	-	0.5	V	
		$V_{CC}=4.5\text{V}$	-	-	1.35	V	
		$V_{CC}=6.0\text{V}$	-	-	1.8	V	
HIGH-level output voltage	V_{OH}	$V_I = V_{IH}$ or V_{IL}	$I_O = -20\mu\text{A}; V_{CC} = 2.0\text{V}$	1.9	-	-	V
			$I_O = -20\mu\text{A}; V_{CC} = 4.5\text{V}$	4.4	-	-	V
			$I_O = -20\mu\text{A}; V_{CC} = 6.0\text{V}$	5.9	-	-	V
			$I_O = -6.0\text{mA}; V_{CC} = 4.5\text{V}$	3.84	-	-	V
			$I_O = -7.8\text{mA}; V_{CC} = 6.0\text{V}$	5.34	-	-	V
LOW-level output voltage	V_{OL}	$V_I = V_{IH}$ or V_{IL}	$I_O = 20\mu\text{A}; V_{CC} = 2.0\text{V}$	-	-	0.1	V
			$I_O = 20\mu\text{A}; V_{CC} = 4.5\text{V}$	-	-	0.1	V
			$I_O = 20\mu\text{A}; V_{CC} = 6.0\text{V}$	-	-	0.1	V
			$I_O = 6.0\text{mA}; V_{CC} = 4.5\text{V}$	-	-	0.33	V
			$I_O = 7.8\text{mA}; V_{CC} = 6.0\text{V}$	-	-	0.33	V
input leakage current	I_I	$V_I = V_{CC}$ or GND; $V_{CC} = 6.0\text{V}$	-	-	± 1	μA	
OFF-state output current	I_{OZ}	$V_I = V_{IH}$ or $V_{IL}; V_O = V_{CC}$ or GND; $V_{CC} = 6.0\text{V}$	-	-	± 5	μA	
supply current	I_{CC}	$V_I = V_{CC}$ or GND; $I_O = 0\text{A};$ $V_{CC} = 6.0\text{V}$	-	-	80	μA	
input capacitance	C_I	-	-	-	-	pF	
AiP74HCT125							
HIGH-level input voltage	V_{IH}	$V_{CC} = 4.5\text{V}$ to 5.5V	2.0	-	-	V	
LOW-level input voltage	V_{IL}	$V_{CC} = 4.5\text{V}$ to 5.5V	-	-	0.8	V	
HIGH-level output voltage	V_{OH}	$V_I = V_{IH}$ or V_{IL}	$I_O = -20\mu\text{A}; V_{CC} = 4.5\text{V}$	4.4	-	-	V
			$I_O = -6.0\text{mA}; V_{CC} = 4.5\text{V}$	3.84	-	-	V
LOW-level output voltage	V_{OL}	$V_I = V_{IH}$ or V_{IL}	$I_O = 20\mu\text{A}; V_{CC} = 4.5\text{V}$	-	-	0.1	V
			$I_O = 6.0\text{mA}; V_{CC} = 4.5\text{V}$	-	-	0.33	V
input leakage current	I_I	$V_I = V_{CC}$ or GND; $V_{CC} = 5.5\text{V}$	-	-	± 1	μA	
OFF-state output current	I_{OZ}	$V_I = V_{IH}$ or $V_{IL}; V_O = V_{CC}$ or GND; $V_{CC} = 5.5\text{V}$	-	-	± 5	μA	
supply current	I_{CC}	$V_I = V_{CC}$ or GND; $I_O = 0\text{A};$ $V_{CC} = 5.5\text{V}$	-	-	80	μA	
additional supply current	ΔI_{CC}	per input pin; $V_I = V_{CC} - 2.1\text{V};$ $I_O = 0\text{A};$ other inputs at V_{CC} or GND; $V_{CC} = 4.5\text{V}$ to 5.5V	-	-	450	μA	
input capacitance	C_I	-	-	-	-	pF	



3.3.3、AC Characteristics 1

($T_{amb}=25^{\circ}\text{C}$, voltages are referenced to GND (ground=0V), unless otherwise specified.)

Parameter	Symbol	Conditions	Min.	Typ.	Max.	Unit	
AiP74HC125							
nA to nY propagation delay	t_{pd}	see Figure 5	$V_{CC}=2.0\text{V}$	-	30	100	ns
			$V_{CC}=4.5\text{V}$	-	11	20	ns
			$V_{CC}=5.0\text{V}; C_L=15\text{pF}$	-	9	-	ns
			$V_{CC}=6.0\text{V}$	-	9	17	ns
nOE to nY enable time	t_{en}	see Figure 6	$V_{CC}=2.0\text{V}$	-	41	125	ns
			$V_{CC}=4.5\text{V}$	-	15	25	ns
			$V_{CC}=6.0\text{V}$	-	12	21	ns
nOE to nY disable time	t_{dis}	see Figure 6	$V_{CC}=2.0\text{V}$	-	41	125	ns
			$V_{CC}=4.5\text{V}$	-	15	25	ns
			$V_{CC}=6.0\text{V}$	-	12	21	ns
transition time	t_t	see Figure 5	$V_{CC}=2.0\text{V}$	-	14	60	ns
			$V_{CC}=4.5\text{V}$	-	5	12	ns
			$V_{CC}=6.0\text{V}$	-	4	10	ns
power dissipation capacitance	C_{PD}	$C_L=50\text{pF}; f=1\text{MHz}; V_I=GND \text{ to } V_{CC}$	-	22	-	pF	
AiP74HCT125							
nA to nY propagation delay	t_{pd}	see Figure 5	$V_{CC}=4.5\text{V}$	-	15	25	ns
			$V_{CC}=5.0\text{V}; C_L=15\text{pF}$	-	12	-	ns
nOE to nY enable time	t_{en}	see Figure 6	$V_{CC}=4.5\text{V}$	-	15	28	ns
nOE to nY disable time	t_{dis}	see Figure 6	$V_{CC}=4.5\text{V}$	-	15	25	ns
transition time	t_t	see Figure 5	$V_{CC}=4.5\text{V}$	-	5	12	ns
power dissipation capacitance	C_{PD}	$C_L=50\text{pF}; f=1\text{MHz}; V_I=GND \text{ to } V_{CC}-1.5\text{V}$	-	24	-	pF	

Note:

- [1] t_{pd} is the same as t_{PLH} and t_{PHL} .
- [2] t_{en} is the same as t_{PZL} and t_{PZH} .
- [3] t_{dis} is the same as t_{PLZ} and t_{PHZ} .
- [4] t_t is the same as t_{THL} and t_{TLH} .
- [5] C_{PD} is used to determine the dynamic power dissipation (P_D in uW).

$$P_D = (C_{PD} \times V_{CC}^2 \times f_i \times N) + \sum (C_L \times V_{CC}^2 \times f_o) \text{ where:}$$

f_i =input frequency in MHz;

f_o =output frequency in MHz;

C_L =output load capacitance in pF;

V_{CC} =supply voltage in V;

N =number of inputs switching;

$\sum (C_L \times V_{CC}^2 \times f_o)$ =sum of outputs.



3.3.4、AC Characteristics 2

($T_{amb}=-40^{\circ}\text{C}$ to $+85^{\circ}\text{C}$, voltages are referenced to GND (ground=0V), unless otherwise specified.)

Parameter	Symbol	Conditions	Min.	Typ.	Max.	Unit	
AiP74HC125							
nA to nY propagation delay	t_{pd}	see Figure 5	$V_{CC}=2.0\text{V}$	-	-	125	ns
			$V_{CC}=4.5\text{V}$	-	-	25	ns
			$V_{CC}=5.0\text{V}; C_L=15\text{pF}$	-	-	-	ns
			$V_{CC}=6.0\text{V}$	-	-	21	ns
nOE to nY enable time	t_{en}	see Figure 6	$V_{CC}=2.0\text{V}$	-	-	155	ns
			$V_{CC}=4.5\text{V}$	-	-	31	ns
			$V_{CC}=6.0\text{V}$	-	-	26	ns
nOE to nY disable time	t_{dis}	see Figure 6	$V_{CC}=2.0\text{V}$	-	-	155	ns
			$V_{CC}=4.5\text{V}$	-	-	31	ns
			$V_{CC}=6.0\text{V}$	-	-	26	ns
transition time	t_t	see Figure 5	$V_{CC}=2.0\text{V}$	-	-	75	ns
			$V_{CC}=4.5\text{V}$	-	-	15	ns
			$V_{CC}=6.0\text{V}$	-	-	13	ns
power dissipation capacitance	C_{PD}	$C_L=50\text{pF}; f=1\text{MHz}; V_I=\text{GND to } V_{CC}$	-	-	-	pF	
AiP74HCT125							
nA to nY propagation delay	t_{pd}	see Figure 5	$V_{CC}=4.5\text{V}$	-	-	31	ns
			$V_{CC}=5.0\text{V}; C_L=15\text{pF}$	-	-	-	ns
nOE to nY enable time	t_{en}	see Figure 6	$V_{CC}=4.5\text{V}$	-	-	35	ns
nOE to nY disable time	t_{dis}	see Figure 6	$V_{CC}=4.5\text{V}$	-	-	31	ns
transition time	t_t	see Figure 5	$V_{CC}=4.5\text{V}$	-	-	15	ns
power dissipation capacitance	C_{PD}	$C_L=50\text{pF}; f=1\text{MHz}; V_I=\text{GND to } V_{CC}-1.5\text{V}$	-	-	-	pF	

Note:

- [1] t_{pd} is the same as t_{PLH} and t_{PHL} .
- [2] t_{en} is the same as t_{PZL} and t_{PZH} .
- [3] t_{dis} is the same as t_{PLZ} and t_{PHZ} .
- [4] t_t is the same as t_{THL} and t_{TLH} .
- [5] C_{PD} is used to determine the dynamic power dissipation (P_D in uW).

$$P_D = (C_{PD} \times V_{CC}^2 \times f_i \times N) + \sum (C_L \times V_{CC}^2 \times f_o) \text{ where:}$$

f_i =input frequency in MHz;

f_o =output frequency in MHz;

C_L =output load capacitance in pF;

V_{CC} =supply voltage in V;

N =number of inputs switching;

$\sum (C_L \times V_{CC}^2 \times f_o)$ =sum of outputs.



4、 Testing Circuit

4.1、 AC Testing Circuit

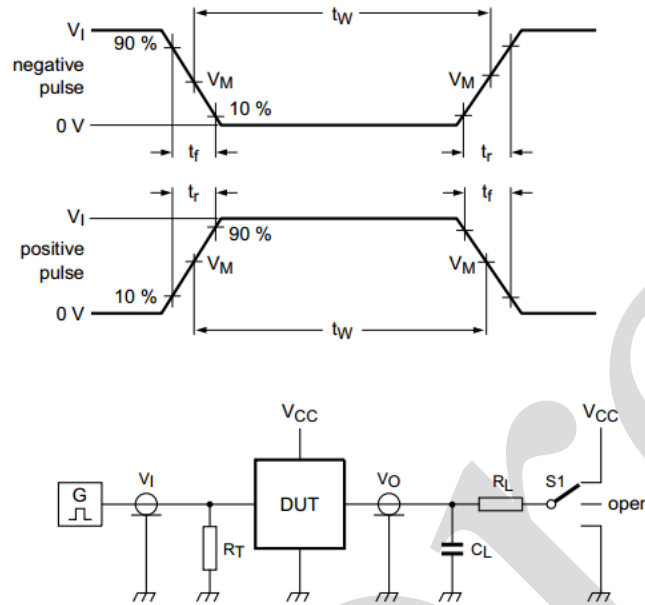

Figure 4. Test circuit for measuring switching times

Definitions for test circuit:

C_L = load capacitance including jig and probe capacitance.

R_T = termination resistance should be equal to the output impedance Z_o of the pulse generator.

R_L = Load resistance.

S1 = Test selection switch.

4.2、 AC Testing Waveforms

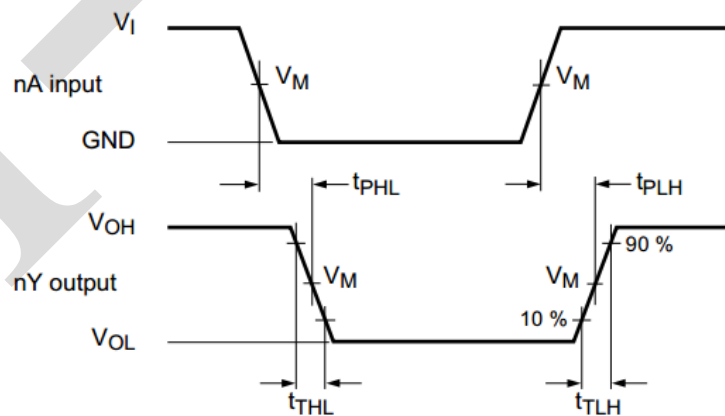

Figure 5. Propagation delay input (nA) to output (nY)

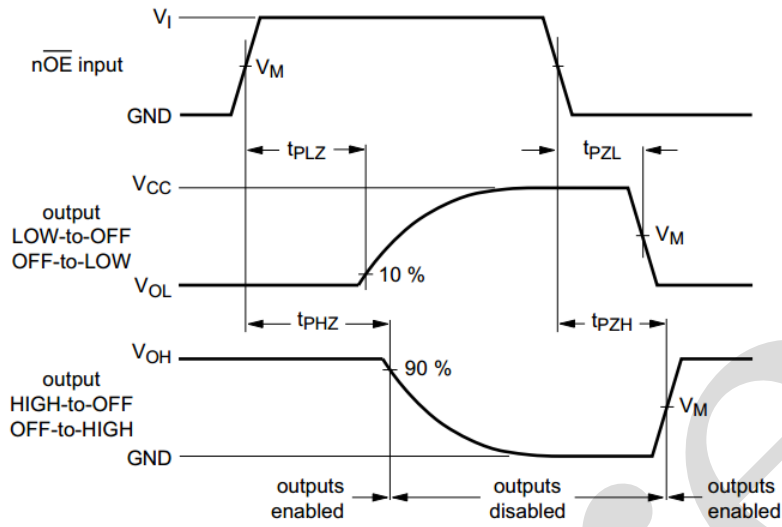

Figure 6. Enable and disable times

4.3. Measurement Points

Type	Input	Output
	V_M	V_M
AiP74HC125	$0.5 \times V_{CC}$	$0.5 \times V_{CC}$
AiP74HCT125	1.3V	1.3V

4.4. Test Data

Type	Input		Load		S1 position		
	V_I	t_r, t_f	C_L	R_L	t_{PHL}, t_{PLH}	t_{PZH}, t_{PHZ}	t_{PZL}, t_{PLZ}
AiP74HC125	V_{CC}	6.0ns	15pF, 50pF	1k Ω	open	GND	V_{CC}
AiP74HCT125	3V	6.0ns	15pF, 50pF	1k Ω	open	GND	V_{CC}



5、Package Information

5.1、DIP14

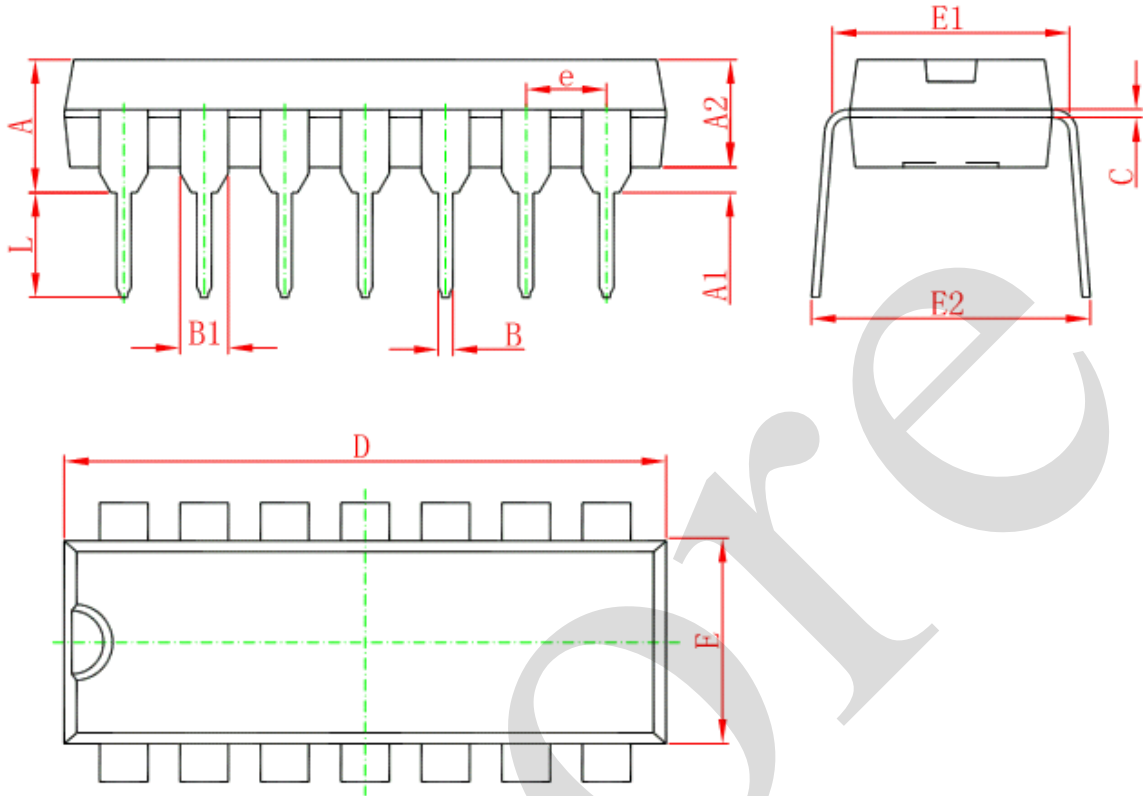

Symbol	Dimensions In Millimeters		Dimensions In Inches	
	Min	Max	Min	Max
A	3.710	4.310	0.146	0.170
A1	0.510		0.020	
A2	3.200	3.600	0.126	0.142
B	0.380	0.570	0.015	0.022
B1	1.524 (BSC)		0.060 (BSC)	
C	0.204	0.360	0.008	0.014
D	18.800	19.200	0.740	0.756
E	6.200	6.600	0.244	0.260
E1	7.320	7.920	0.288	0.312
e	2.540 (BSC)		0.100 (BSC)	
L	3.000	3.600	0.118	0.142
E2	8.400	9.000	0.331	0.354



5.2、SOP14

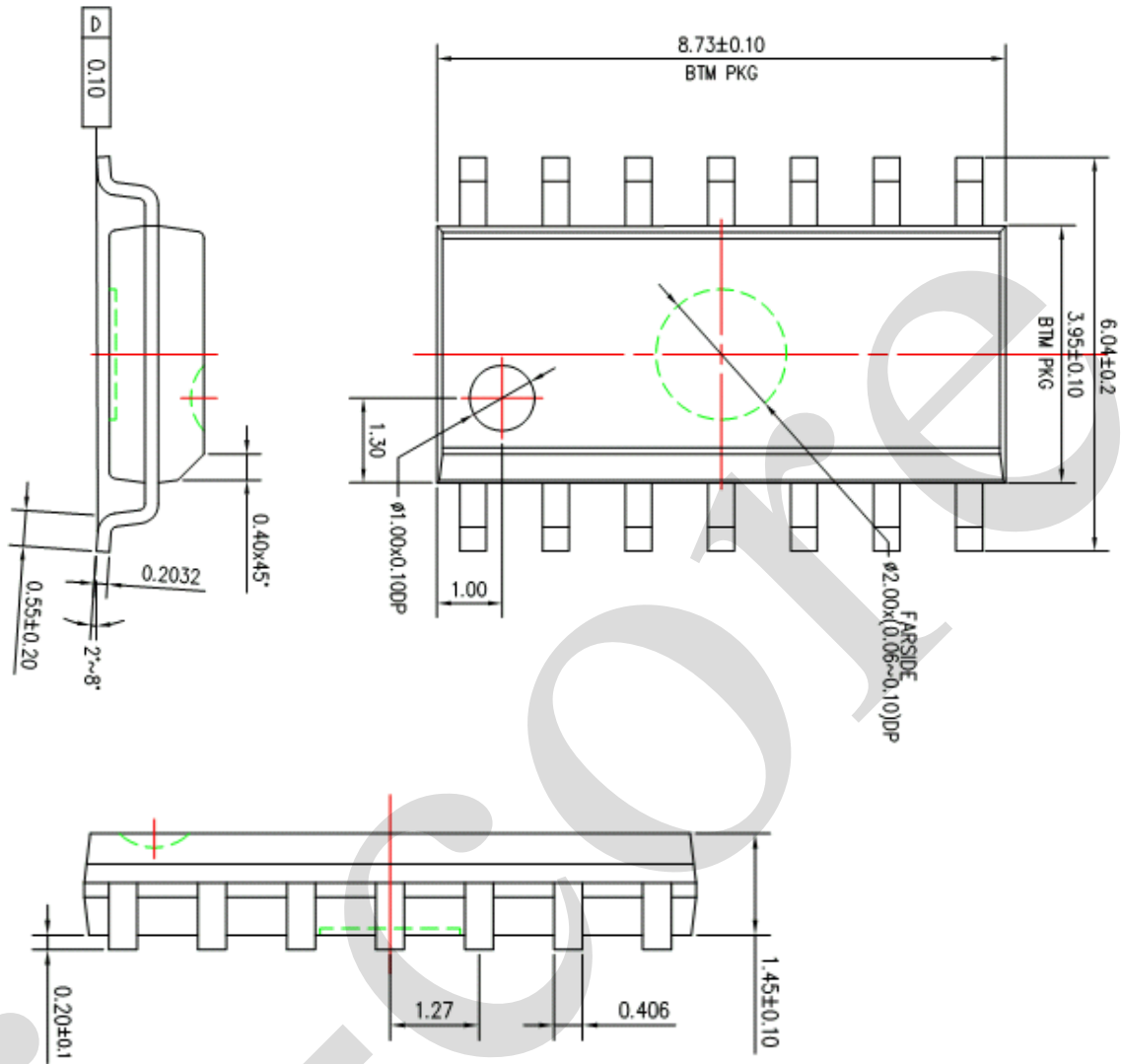



5.3、TSSOP14

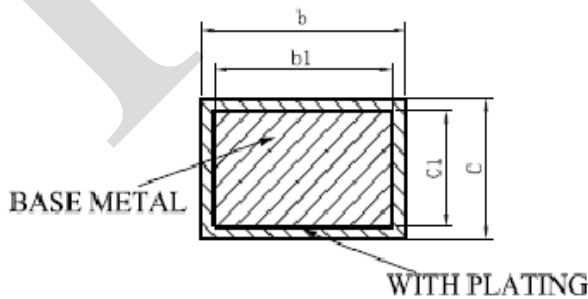
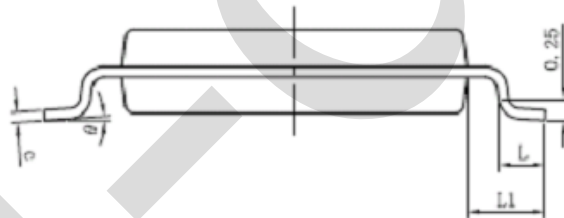
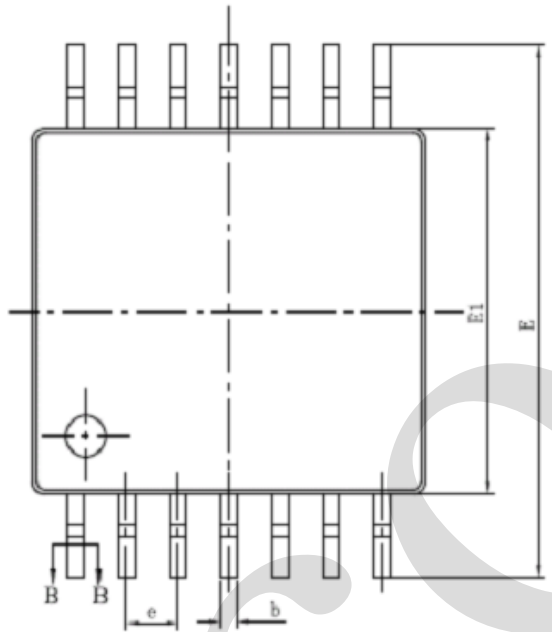
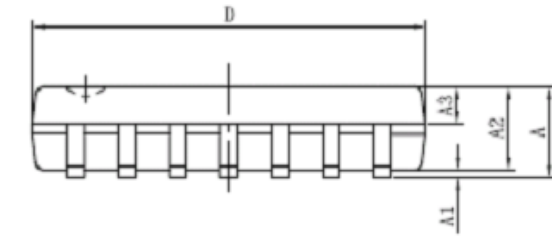

SECTION B-B

SYMBOL	MILLIMETER	
	MIN	MAX
A	—	1.20
A1	0.05	0.15
A2	0.90	1.05
A3	0.39	0.49
b	0.20	0.30
b1	0.19	0.25
c	0.13	0.19
c1	0.12	0.14
D	4.86	5.06
E1	4.30	4.50
E	6.20	6.60
e	0.65BSC	
L	0.45	0.75
L1	1.00BSC	
θ	0	8°



6、 Statements And Notes

6.1、 The name and content of Hazardous substances or Elements in the product

Part name	Hazardous substances or Elements									
	Lead and lead compounds	Mercury and mercury compounds	Cadmium and cadmium compounds	Hexavalent chromium compounds	Polybrominated biphenyls	Polybrominated biphenyl ethers	Dibutyl phthalate	Butylbenzyl phthalate	Di-2-ethylhexyl phthalate	Diisobutyl phthalate
Lead frame	○	○	○	○	○	○	○	○	○	○
Plastic resin	○	○	○	○	○	○	○	○	○	○
Chip	○	○	○	○	○	○	○	○	○	○
The lead	○	○	○	○	○	○	○	○	○	○
Plastic sheet installed	○	○	○	○	○	○	○	○	○	○
explanation	○: Indicates that the content of hazardous substances or elements in the detection limit of the following the SJ/T11363-2006 standard. ×: Indicates that the content of hazardous substances or elements exceeding the SJ/T11363-2006 Standard limit requirements.									

6.2、 Notion

Recommended carefully reading this information before the use of this product;

The information in this document are subject to change without notice;

This information is using to the reference only, the company is not responsible for any loss;

The company is not responsible for the any infringement of the third party patents or other rights of the responsibility.

X-ON Electronics

Largest Supplier of Electrical and Electronic Components

Click to view similar products for [Buffers & Line Drivers](#) category:

Click to view products by [I-core](#) manufacturer:

Other Similar products are found below :

[LXV200-024SW](#) [74AUP2G34FW3-7](#) [HEF4043BP](#) [NL17SG125DFT2G](#) [NLU1GT126CMUTCG](#) [CD4041UBE](#) [54FCT240CTDB](#)
[74HCT540N](#) [DS14C88N](#) [070519XB](#) [NL17SZ07P5T5G](#) [74LVC2G17FW4-7](#) [CD4502BE](#) [5962-8982101PA](#) [61446R00](#) [NL17SH17P5T5G](#)
[NLV37WZ17USG](#) [74HCT126T14-13](#) [74VHC9126FT\(BJ\)](#) [RHRXH162244K1](#) [74AUP1G34FW5-7](#) [74AUP1G07FW5-7](#) [74LVC1G126FW4-7](#)
[74LVC2G126RA3-7](#) [74LVCE1G125FZ4-7](#) [54FCT240TLB](#) [NLX3G16DMUTCG](#) [NLX2G06AMUTCG](#) [LE87100NQCT](#) [LE87285NQC](#)
[LE87290YQC](#) [LE87290YQCT](#) [74AUP1G125FW5-7](#) [NLU2G16CMUTCG](#) [MC74LCX244MN2TWG](#) [NL17SG17P5T5G](#)
[NLV74HC125ADR2G](#) [NLVHCT245ADTR2G](#) [NLVVHC1G126DFT2G](#) [EL5623IRZ](#) [ISL15102AIRZ-T13](#) [ISL1539IRZ-T13](#)
[MC100EP17MNG](#) [MC74HCT365ADR2G](#) [MC74LCX244ADTR2G](#) [NL27WZ126US](#) [NL37WZ16US](#) [NLU1G07MUTCG](#) [NLU2G07MUTCG](#)
[NLX3G17BMX1TCG](#)