



# **AiP74HC/HCT244**

## **Octal Buffer/Line Driver; 3-state**

### **Product Specification**

**Specification Revision History:**

<b>Version</b>	<b>Date</b>	<b>Description</b>
2019-06-A1	2019-06	New



## 1、 General Description

The AiP74HC/HCT244 is an 8-bit buffer/line driver with 3-state outputs. The device can be used as two 4-bit buffers or one 8-bit buffer. The device features two output enables ( $1\overline{OE}$  and  $2\overline{OE}$ ), each controlling four of the 3-state outputs. A HIGH on  $n\overline{OE}$  causes the outputs to assume a high-impedance OFF-state. Inputs include clamp diodes that enable the use of current limiting resistors to interface inputs to voltages in excess of  $V_{CC}$ .

### Features:

- Input levels:
  - For AiP74HC244: CMOS level
  - For AiP74HCT244: TTL level
- Octal bus interface
- Non-inverting 3-state outputs
- Multiple package options
- Specified from  $-40^{\circ}\text{C}$  to  $+85^{\circ}\text{C}$
- Packaging information: DIP20/SOP20/TSSOP20

**Ordering Information:****Tube packing specifications:**

Type number	Packaging form	Marking code	Tube quantity	Boxed tube quantity	Boxed quantity	Packing box number	Packing quantity	Notes
AiP74HC244DA.TB	DIP20	74HC244	18 PCS/tube	40 tube/box	720 PCS/box	10 box/pack	7200 PCS/pack	Dimensions of plastic enclosure: 26.3mm×6.4mm Pin spacing: 2.54mm
AiP74HCT244DA.TB	DIP20	74HCT244	18 PCS/tube	40 tube/box	720 PCS/box	10 box/pack	7200 PCS/pack	Dimensions of plastic enclosure: 26.3mm×6.4mm Pin spacing: 2.54mm
AiP74HC244SA.TB	SOP20	74HC244	35 PCS/tube	80 tube/box	2800 PCS/box	10 box/pack	28000 PCS/pack	Dimensions of plastic enclosure: 12.8mm×7.5mm Pin spacing: 1.27mm
AiP74HCT244SA.TB	SOP20	74HCT244	35 PCS/tube	80 tube/box	2800 PCS/box	10 box/pack	28000 PCS/pack	Dimensions of plastic enclosure: 12.8mm×7.5mm Pin spacing: 1.27mm
AiP74HC244TA.TB	TSSOP20	74HC244	70 PCS/tube	200 tube/box	14000 PCS/box	10 box/pack	140000 PCS/pack	Dimensions of plastic enclosure: 6.5mm×4.4mm Pin spacing: 0.65mm
AiP74HCT244TA.TB	TSSOP20	74HCT244	70 PCS/tube	200 tube/box	14000 PCS/box	10 box/pack	140000 PCS/pack	Dimensions of plastic enclosure: 6.5mm×4.4mm Pin spacing: 0.65mm

**Reel packing specifications:**

Type number	Packaging form	Marking code	Reel quantity	Boxed reel quantity	Packing quantity	Notes
AiP74HC244SA.TR	SOP20	74HC244	1000PCS/reel	1000PCS/box	8000PCS/pack	Dimensions of plastic enclosure: 12.8mm×7.5mm Pin spacing:1.27mm
AiP74HCT244SA.TR	SOP20	74HCT244	1000PCS/reel	1000PCS/box	8000PCS/pack	Dimensions of plastic enclosure: 12.8mm×7.5mm Pin spacing:1.27mm
AiP74HC244TA.TR	TSSOP20	74HC244	2500PCS/reel	5000PCS/box	40000PCS/pack	Dimensions of plastic enclosure: 6.5mm×4.4mm Pin spacing:0.65mm
AiP74HCT244TA.TR	TSSOP20	74HCT244	2500PCS/reel	5000PCS/box	40000PCS/pack	Dimensions of plastic enclosure: 6.5mm×4.4mm Pin spacing:0.65mm

Note: If the physical information is inconsistent with the ordering information, please refer to the actual product.



## 2、Block Diagram And Pin Description

### 2.1、Block Diagram

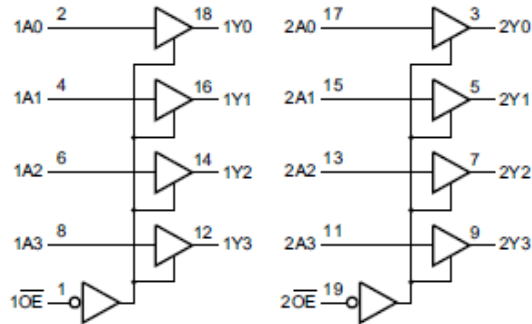

Figure 1. Logic symbol

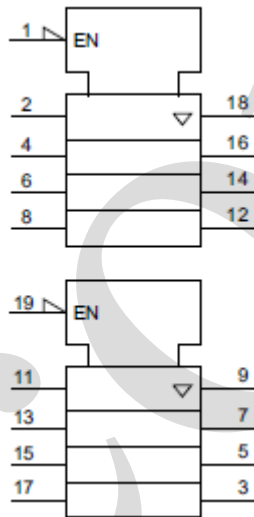

Figure 2. IEC logic symbol

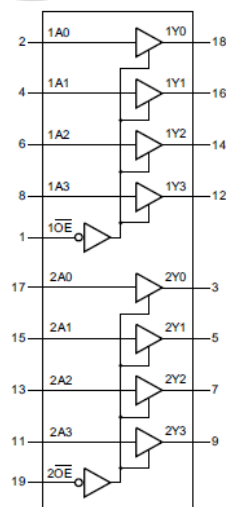
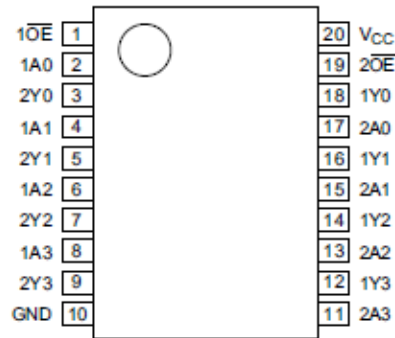

Figure 3. Functional diagram



## 2.2、Pin Configurations



## 2.3、Pin Description

Pin No.	Pin Name	Description
1	1OE	output enable input (active LOW)
2	1A0	data input
3	2Y0	bus output
4	1A1	data input
5	2Y1	bus output
6	1A2	data input
7	2Y2	bus output
8	1A3	data input
9	2Y3	bus output
10	GND	ground (0V)
11	2A3	data input
12	1Y3	bus output
13	2A2	data input
14	1Y2	bus output
15	2A1	data input
16	1Y1	bus output
17	2A0	data input
18	1Y0	bus output
19	2OE	output enable input (active LOW)
20	V <sub>CC</sub>	supply voltage

## 2.4、Function Table

Input		Output
nOE	nAn	nYn
L	L	L
L	H	H
H	X	Z

Note: H=HIGH voltage level; L=LOW voltage level; X=don't care; Z=high-impedance OFF-state.



## 3、Electrical Parameter

### 3.1、Absolute Maximum Ratings

(Voltages are referenced to GND(ground=0V), unless otherwise specified.)

Parameter	Symbol	Conditions	Min.	Max.	Unit
supply voltage	$V_{CC}$	-	-0.5	+7.0	V
input clamping current	$I_{IK}$	$V_I < -0.5V$ or $V_I > V_{CC}+0.5V$	-	$\pm 20$	mA
output clamping current	$I_{OK}$	$V_O < -0.5V$ or $V_O > V_{CC}+0.5V$	-	$\pm 20$	mA
output current	$I_O$	$-0.5V < V_O < V_{CC}+0.5V$	-	$\pm 35$	mA
supply current	$I_{CC}$	-	-	70	mA
ground current	$I_{GND}$	-	-70	-	mA
storage temperature	$T_{stg}$	-	-65	+150	$^{\circ}C$
total power dissipation	$P_{tot}$	-	-	500	mW
Soldering temperature	$T_L$	10s	DIP	245	$^{\circ}C$
			SOP	250	$^{\circ}C$

Note:

[1] For DIP20 packages: above  $70^{\circ}C$  the value of  $P_{tot}$  derates linearly with 12mW/K.

[2] For SOP20 packages: above  $70^{\circ}C$  the value of  $P_{tot}$  derates linearly with 8mW/K.

[3] For (T)SSOP20 packages: above  $60^{\circ}C$  the value of  $P_{tot}$  derates linearly with 5.5mW/K.

### 3.2、Recommended Operating Conditions

Parameter	Symbol	Conditions	Min.	Typ.	Max.	Unit
AiP74HC244						
supply voltage	$V_{CC}$	-	2.0	5.0	6.0	V
input voltage	$V_I$	-	0	-	$V_{CC}$	V
output voltage	$V_O$	-	0	-	$V_{CC}$	V
input transition rise and fall rate	$\Delta t/\Delta V$	$V_{CC}=2.0V$	-	-	625	ns/V
		$V_{CC}=4.5V$	-	1.67	139	ns/V
		$V_{CC}=6.0V$	-	-	83	ns/V
ambient temperature	$T_{amb}$	-	-40	-	+85	$^{\circ}C$
AiP74HCT244						
supply voltage	$V_{CC}$	-	4.5	5.0	5.5	V
input voltage	$V_I$	-	0	-	$V_{CC}$	V
output voltage	$V_O$	-	0	-	$V_{CC}$	V
input transition rise and fall rate	$\Delta t/\Delta V$	$V_{CC}=4.5V$	-	1.67	139	ns/V
ambient temperature	$T_{amb}$	-	-40	-	+85	$^{\circ}C$



### 3.3、Electrical Characteristics

#### 3.3.1、DC Characteristics 1

( $T_{amb}=25^{\circ}C$ , voltages are referenced to GND (ground=0V), unless otherwise specified.)

Parameter	Symbol	Conditions	Min.	Typ.	Max.	Unit	
<b>AiP74HC244</b>							
HIGH-level input voltage	$V_{IH}$	$V_{CC}=2.0V$	1.5	1.2	-	V	
		$V_{CC}=4.5V$	3.15	2.4	-	V	
		$V_{CC}=6.0V$	4.2	3.2	-	V	
LOW-level input voltage	$V_{IL}$	$V_{CC}=2.0V$	-	0.8	0.5	V	
		$V_{CC}=4.5V$	-	2.1	1.35	V	
		$V_{CC}=6.0V$	-	2.8	1.8	V	
HIGH-level output voltage	$V_{OH}$	$V_I = V_{IH} \text{ or } V_{IL}$	$I_O=-20\mu A; V_{CC}=2.0V$	1.9	2.0	-	V
			$I_O=-20\mu A; V_{CC}=4.5V$	4.4	4.5	-	V
			$I_O=-20\mu A; V_{CC}=6.0V$	5.9	6.0	-	V
			$I_O=-6.0mA; V_{CC}=4.5V$	3.98	4.32	-	V
			$I_O=-7.8mA; V_{CC}=6.0V$	5.48	5.81	-	V
LOW-level output voltage	$V_{OL}$	$V_I = V_{IH} \text{ or } V_{IL}$	$I_O=20\mu A; V_{CC}=2.0V$	-	0	0.1	V
			$I_O=20\mu A; V_{CC}=4.5V$	-	0	0.1	V
			$I_O=20\mu A; V_{CC}=6.0V$	-	0	0.1	V
			$I_O=6.0mA; V_{CC}=4.5V$	-	0.15	0.26	V
			$I_O=7.8mA; V_{CC}=6.0V$	-	0.16	0.26	V
input leakage current	$I_I$	$V_I=V_{CC} \text{ or } GND; V_{CC}=6.0V$	-	-	$\pm 0.1$	$\mu A$	
OFF-state output current	$I_{OZ}$	$V_I=V_{IH} \text{ or } V_{IL}; V_{CC}=6.0V; V_O=V_{CC} \text{ or } GND$	-	-	$\pm 0.5$	$\mu A$	
supply current	$I_{CC}$	$V_I=V_{CC} \text{ or } GND; I_O=0A; V_{CC}=6.0V$	-	-	8.0	$\mu A$	
input capacitance	$C_I$	-	-	3.5	-	pF	
<b>AiP74HCT244</b>							
HIGH-level input voltage	$V_{IH}$	$V_{CC}=4.5V \text{ to } 5.5V$	2.0	1.6	-	V	
LOW-level input voltage	$V_{IL}$	$V_{CC}=4.5V \text{ to } 5.5V$	-	1.2	0.8	V	
HIGH-level output voltage	$V_{OH}$	$V_I = V_{IH} \text{ or } V_{IL}; V_{CC}=4.5V$	$I_O=-20\mu A$	4.4	4.5	-	V
			$I_O=-6.0mA$	3.98	4.32	-	V
LOW-level output voltage	$V_{OL}$	$V_I = V_{IH} \text{ or } V_{IL}; V_{CC}=4.5V$	$I_O=20\mu A$	-	0	0.1	V
			$I_O=6.0mA$	-	0.16	0.26	V
input leakage current	$I_I$	$V_I=V_{CC} \text{ or } GND; V_{CC}=5.5V$	-	-	$\pm 0.1$	$\mu A$	
OFF-state output current	$I_{OZ}$	$V_I=V_{IH} \text{ or } V_{IL}; V_{CC}=5.5V; V_O=V_{CC} \text{ or } GND$	-	-	$\pm 0.5$	$\mu A$	
supply current	$I_{CC}$	$V_I=V_{CC} \text{ or } GND; I_O=0A; V_{CC}=5.5V$	-	-	8.0	$\mu A$	
additional supply current	$\Delta I_{CC}$	per input pin; $V_I=V_{CC}-2.1V$ ; other inputs at $V_{CC}$ or GND; $V_{CC}=4.5V \text{ to } 5.5V; I_O=0A$	-	70	252	$\mu A$	
input capacitance	$C_I$	-	-	3.5	-	pF	



### 3.3.2、DC Characteristics 2

( $T_{amb} = -40^{\circ}\text{C}$  to  $+85^{\circ}\text{C}$ , voltages are referenced to GND (ground=0V), unless otherwise specified.)

Parameter	Symbol	Conditions	Min.	Typ.	Max.	Unit	
AiP74HC244							
HIGH-level input voltage	$V_{IH}$	$V_{CC}=2.0\text{V}$	1.5	-	-	V	
		$V_{CC}=4.5\text{V}$	3.15	-	-	V	
		$V_{CC}=6.0\text{V}$	4.2	-	-	V	
LOW-level input voltage	$V_{IL}$	$V_{CC}=2.0\text{V}$	-	-	0.5	V	
		$V_{CC}=4.5\text{V}$	-	-	1.35	V	
		$V_{CC}=6.0\text{V}$	-	-	1.8	V	
HIGH-level output voltage	$V_{OH}$	$V_I = V_{IH}$ or $V_{IL}$	$I_O = -20\mu\text{A}; V_{CC} = 2.0\text{V}$	1.9	-	-	V
			$I_O = -20\mu\text{A}; V_{CC} = 4.5\text{V}$	4.4	-	-	V
			$I_O = -20\mu\text{A}; V_{CC} = 6.0\text{V}$	5.9	-	-	V
			$I_O = -6.0\text{mA}; V_{CC} = 4.5\text{V}$	3.84	-	-	V
			$I_O = -7.8\text{mA}; V_{CC} = 6.0\text{V}$	5.34	-	-	V
LOW-level output voltage	$V_{OL}$	$V_I = V_{IH}$ or $V_{IL}$	$I_O = 20\mu\text{A}; V_{CC} = 2.0\text{V}$	-	-	0.1	V
			$I_O = 20\mu\text{A}; V_{CC} = 4.5\text{V}$	-	-	0.1	V
			$I_O = 20\mu\text{A}; V_{CC} = 6.0\text{V}$	-	-	0.1	V
			$I_O = 6.0\text{mA}; V_{CC} = 4.5\text{V}$	-	-	0.33	V
			$I_O = 7.8\text{mA}; V_{CC} = 6.0\text{V}$	-	-	0.33	V
input leakage current	$I_I$	$V_I = V_{CC}$ or GND; $V_{CC} = 6.0\text{V}$	-	-	$\pm 1.0$	$\mu\text{A}$	
OFF-state output current	$I_{OZ}$	$V_I = V_{IH}$ or $V_{IL}; V_{CC} = 6.0\text{V};$ $V_O = V_{CC}$ or GND	-	-	$\pm 5.0$	$\mu\text{A}$	
supply current	$I_{CC}$	$V_I = V_{CC}$ or GND; $I_O = 0\text{A}; V_{CC} = 6.0\text{V}$	-	-	80	$\mu\text{A}$	
input capacitance	$C_I$	-	-	-	-	pF	
AiP74HCT244							
HIGH-level input voltage	$V_{IH}$	$V_{CC} = 4.5\text{V}$ to $5.5\text{V}$	2.0	-	-	V	
LOW-level input voltage	$V_{IL}$	$V_{CC} = 4.5\text{V}$ to $5.5\text{V}$	-	-	0.8	V	
HIGH-level output voltage	$V_{OH}$	$V_I = V_{IH}$ or $V_{IL};$ $V_{CC} = 4.5\text{V}$	$I_O = -20\mu\text{A}$	4.4	-	-	V
			$I_O = -6.0\text{mA}$	3.84	-	-	V
LOW-level output voltage	$V_{OL}$	$V_I = V_{IH}$ or $V_{IL};$ $V_{CC} = 4.5\text{V}$	$I_O = 20\mu\text{A}$	-	-	0.1	V
			$I_O = 6.0\text{mA}$	-	-	0.33	V
input leakage current	$I_I$	$V_I = V_{CC}$ or GND; $V_{CC} = 5.5\text{V}$	-	-	$\pm 1.0$	$\mu\text{A}$	
OFF-state output current	$I_{OZ}$	$V_I = V_{IH}$ or $V_{IL}; V_{CC} = 5.5\text{V};$ $V_O = V_{CC}$ or GND	-	-	$\pm 5.0$	$\mu\text{A}$	
supply current	$I_{CC}$	$V_I = V_{CC}$ or GND; $I_O = 0\text{A}; V_{CC} = 5.5\text{V}$	-	-	80	$\mu\text{A}$	
additional supply current	$\Delta I_{CC}$	per input pin; $V_I = V_{CC} - 2.1\text{V};$ other inputs at $V_{CC}$ or GND; $V_{CC} = 4.5\text{V}$ to $5.5\text{V}; I_O = 0\text{A}$	-	-	315	$\mu\text{A}$	
input capacitance	$C_I$	-	-	-	-	pF	





### 3.3.3、AC Characteristics 1

( $T_{amb}=25^{\circ}\text{C}$ , voltages are referenced to GND (ground=0V), unless otherwise specified.)

Parameter	Symbol	Conditions	Min.	Typ.	Max.	Unit	
AiP74HC244							
nAn to nYn propagation delay	$t_{pd}$	see Figure 5	$V_{CC}=2.0\text{V}$	-	30	110	ns
			$V_{CC}=4.5\text{V}$	-	11	22	ns
			$V_{CC}=5.0\text{V}; C_L=15\text{pF}$	-	9	-	ns
			$V_{CC}=6.0\text{V}$	-	9	19	ns
nOE to nYn enable time	$t_{en}$	see Figure 6	$V_{CC}=2.0\text{V}$	-	36	150	ns
			$V_{CC}=4.5\text{V}$	-	13	30	ns
			$V_{CC}=6.0\text{V}$	-	10	26	ns
nOE to nYn disable time	$t_{dis}$	see Figure 6	$V_{CC}=2.0\text{V}$	-	39	150	ns
			$V_{CC}=4.5\text{V}$	-	14	30	ns
			$V_{CC}=6.0\text{V}$	-	11	26	ns
transition time	$t_t$	see Figure 5	$V_{CC}=2.0\text{V}$	-	14	60	ns
			$V_{CC}=4.5\text{V}$	-	5	12	ns
			$V_{CC}=6.0\text{V}$	-	4	10	ns
power dissipation capacitance	$C_{PD}$	per buffer; $V_I=\text{GND to } V_{CC}$	-	35	-	pF	
AiP74HCT244							
nAn to nYn propagation delay	$t_{pd}$	see Figure 5	$V_{CC}=4.5\text{V}$	-	13	22	ns
			$V_{CC}=5.0\text{V}; C_L=15\text{pF}$	-	11	-	ns
nOE to nYn enable time	$t_{en}$	$V_{CC}=4.5\text{V};$ see Figure 6	-	15	30	ns	
nOE to nYn disable time	$t_{dis}$	$V_{CC}=4.5\text{V};$ see Figure 6	-	15	25	ns	
transition time	$t_t$	$V_{CC}=4.5\text{V};$ see Figure 5	-	5	12	ns	
power dissipation capacitance	$C_{PD}$	per buffer; $V_I=\text{GND to } V_{CC}-1.5\text{V}$	-	35	-	pF	

Note:

[1]  $t_{pd}$  is the same as  $t_{PLH}$  and  $t_{PHL}$ .

[2]  $t_{en}$  is the same as  $t_{PZL}$  and  $t_{PZH}$ .

[3]  $t_{dis}$  is the same as  $t_{PLZ}$  and  $t_{PHZ}$ .

[4]  $t_t$  is the same as  $t_{THL}$  and  $t_{TLH}$ .

[5]  $C_{PD}$  is used to determine the dynamic power dissipation ( $P_D$  in uW).

$$P_D = C_{PD} \times V_{CC}^2 \times f_i \times N + \sum (C_L \times V_{CC}^2 \times f_o) \text{ where:}$$

$f_i$ =input frequency in MHz;

$f_o$ =output frequency in MHz;

$C_L$ =output load capacitance in pF;

$V_{CC}$ =supply voltage in V;

$N$ =number of inputs switching;

$\sum (C_L \times V_{CC}^2 \times f_o)$ =sum of outputs.



### 3.3.4、AC Characteristics 2

( $T_{amb}=-40^{\circ}\text{C}$  to  $+85^{\circ}\text{C}$ , voltages are referenced to GND (ground=0V), unless otherwise specified.)

Parameter	Symbol	Conditions	Min.	Typ.	Max.	Unit	
AiP74HC244							
nAn to nYn propagation delay	$t_{pd}$	see Figure 5	$V_{CC}=2.0\text{V}$	-	-	145	ns
			$V_{CC}=4.5\text{V}$	-	-	28	ns
			$V_{CC}=5.0\text{V}; C_L=15\text{pF}$	-	-	-	ns
			$V_{CC}=6.0\text{V}$	-	-	24	ns
nOE to nYn enable time	$t_{en}$	see Figure 6	$V_{CC}=2.0\text{V}$	-	-	190	ns
			$V_{CC}=4.5\text{V}$	-	-	38	ns
			$V_{CC}=6.0\text{V}$	-	-	33	ns
nOE to nYn disable time	$t_{dis}$	see Figure 6	$V_{CC}=2.0\text{V}$	-	-	190	ns
			$V_{CC}=4.5\text{V}$	-	-	38	ns
			$V_{CC}=6.0\text{V}$	-	-	33	ns
transition time	$t_t$	see Figure 5	$V_{CC}=2.0\text{V}$	-	-	75	ns
			$V_{CC}=4.5\text{V}$	-	-	15	ns
			$V_{CC}=6.0\text{V}$	-	-	13	ns
power dissipation capacitance	$C_{PD}$	per buffer; $V_I=\text{GND}$ to $V_{CC}$	-	-	-	pF	
AiP74HCT244							
nAn to nYn propagation delay	$t_{pd}$	see Figure 5	$V_{CC}=4.5\text{V}$	-	-	22	ns
			$V_{CC}=5.0\text{V}; C_L=15\text{pF}$	-	-	-	ns
nOE to nYn enable time	$t_{en}$	$V_{CC}=4.5\text{V}$ ; see Figure 6	-	-	30	ns	
nOE to nYn disable time	$t_{dis}$	$V_{CC}=4.5\text{V}$ ; see Figure 6	-	-	25	ns	
transition time	$t_t$	$V_{CC}=4.5\text{V}$ ; see Figure 5	-	-	12	ns	
power dissipation capacitance	$C_{PD}$	per buffer; $V_I=\text{GND}$ to $V_{CC}-1.5\text{V}$	-	-	-	pF	

Note:

[1]  $t_{pd}$  is the same as  $t_{PLH}$  and  $t_{PHL}$ .

[2]  $t_{en}$  is the same as  $t_{PZL}$  and  $t_{PZH}$ .

[3]  $t_{dis}$  is the same as  $t_{PLZ}$  and  $t_{PHZ}$ .

[4]  $t_t$  is the same as  $t_{THL}$  and  $t_{TLH}$ .

[5]  $C_{PD}$  is used to determine the dynamic power dissipation ( $P_D$  in uW).

$$P_D = C_{PD} \times V_{CC}^2 \times f_i \times N + \sum (C_L \times V_{CC}^2 \times f_o) \text{ where:}$$

$f_i$ =input frequency in MHz;

$f_o$ =output frequency in MHz;

$C_L$ =output load capacitance in pF;

$V_{CC}$ =supply voltage in V;

$N$ =number of inputs switching;

$\sum (C_L \times V_{CC}^2 \times f_o)$ =sum of outputs.



## 4、 Testing Circuit

### 4.1、 AC Testing Circuit

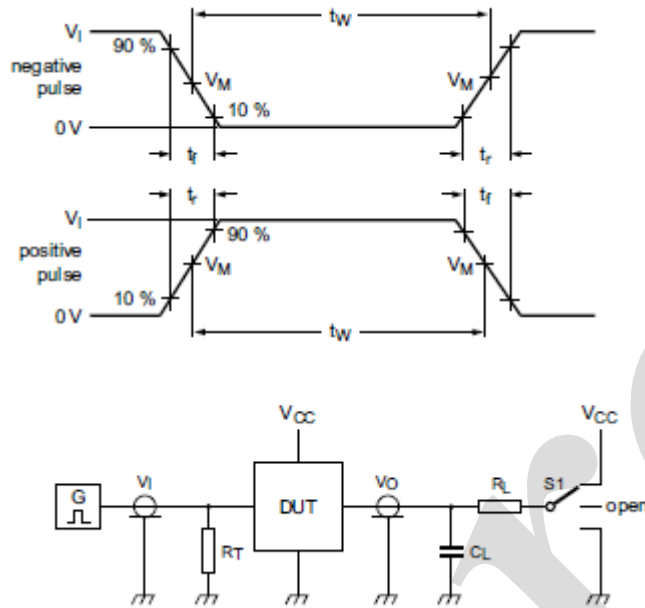

Figure 4. Test circuit for measuring switching times

Definitions for test circuit:

$R_L$ =Load resistance.

$C_L$ =Load capacitance including jig and probe capacitance.

$R_T$ =Termination resistance should be equal to the output impedance  $Z_o$  of the pulse generator.

S1=Test selection switch.

### 4.2、 AC Testing Waveforms

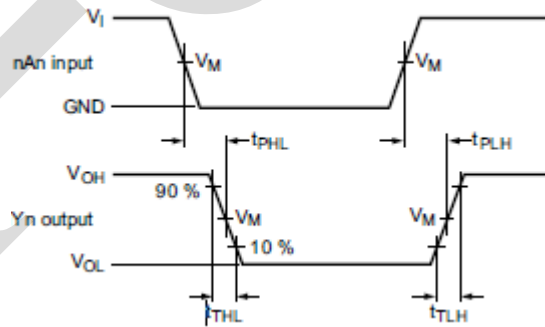

Figure 5. Input (nAn) to output (nYn) propagation delays and output transition times

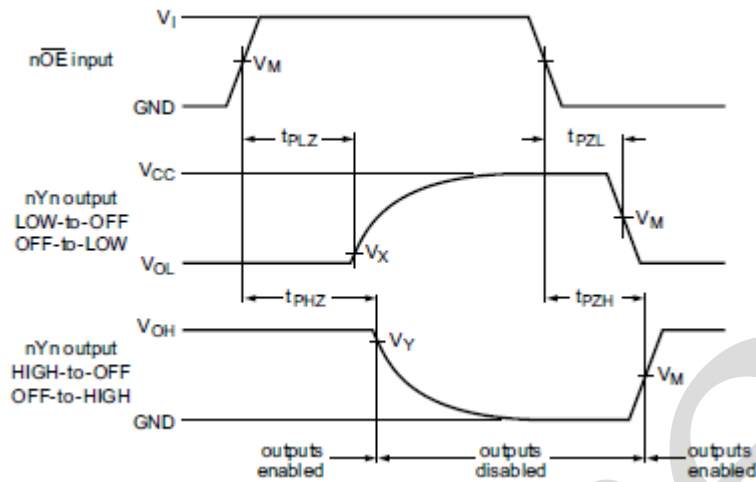

Figure 6. 3-state enable and disable times

#### 4.3. Measurement Points

Type	Input		Output		
	$V_M$	$V_M$	$V_X$	$V_Y$	$V_Y$
AiP74HC244	$0.5 \times V_{CC}$	$0.5 \times V_{CC}$	$0.1 \times V_{CC}$	$0.9 \times V_{CC}$	$0.9 \times V_{CC}$
AiP74HCT244	1.3V	1.3V	$0.1 \times V_{CC}$	$0.9 \times V_{CC}$	$0.9 \times V_{CC}$

#### 4.4. Test Data

Type	Input		Load		S1 position		
	$V_I$	$t_r, t_f$	$C_L$	$R_L$	$t_{PHL}, t_{PLH}$	$t_{PZH}, t_{PHZ}$	$t_{PZL}, t_{PLZ}$
AiP74HC244	$V_{CC}$	6ns	15pF, 50pF	1k $\Omega$	open	GND	$V_{CC}$
AiP74HCT244	3V	6ns	15pF, 50pF	1k $\Omega$	open	GND	$V_{CC}$



## 5、 Package Information

### 5.1、 DIP20

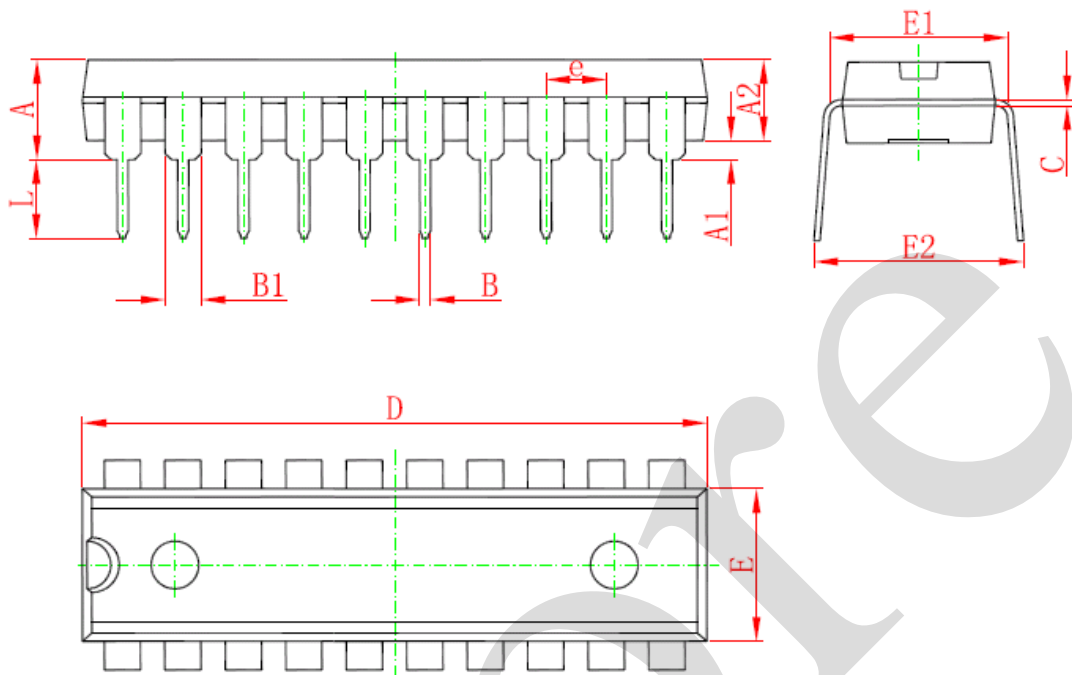

Symbol	Dimensions In Millimeters		Dimensions In Inches	
	Min	Max	Min	Max
A	3.710	4.310	0.146	0.170
A1	0.510		0.020	
A2	3.200	3.600	0.126	0.142
B	0.380	0.570	0.015	0.022
B1	1.524 (BSC)		0.060 (BSC)	
C	0.204	0.360	0.008	0.014
D	25.950	26.550	1.022	1.045
E	6.200	6.600	0.244	0.260
E1	7.320	7.920	0.288	0.312
e	2.540 (BSC)		0.100 (BSC)	
L	3.000	3.600	0.118	0.142
E2	8.400	9.000	0.331	0.354



## 5.2、SOP20

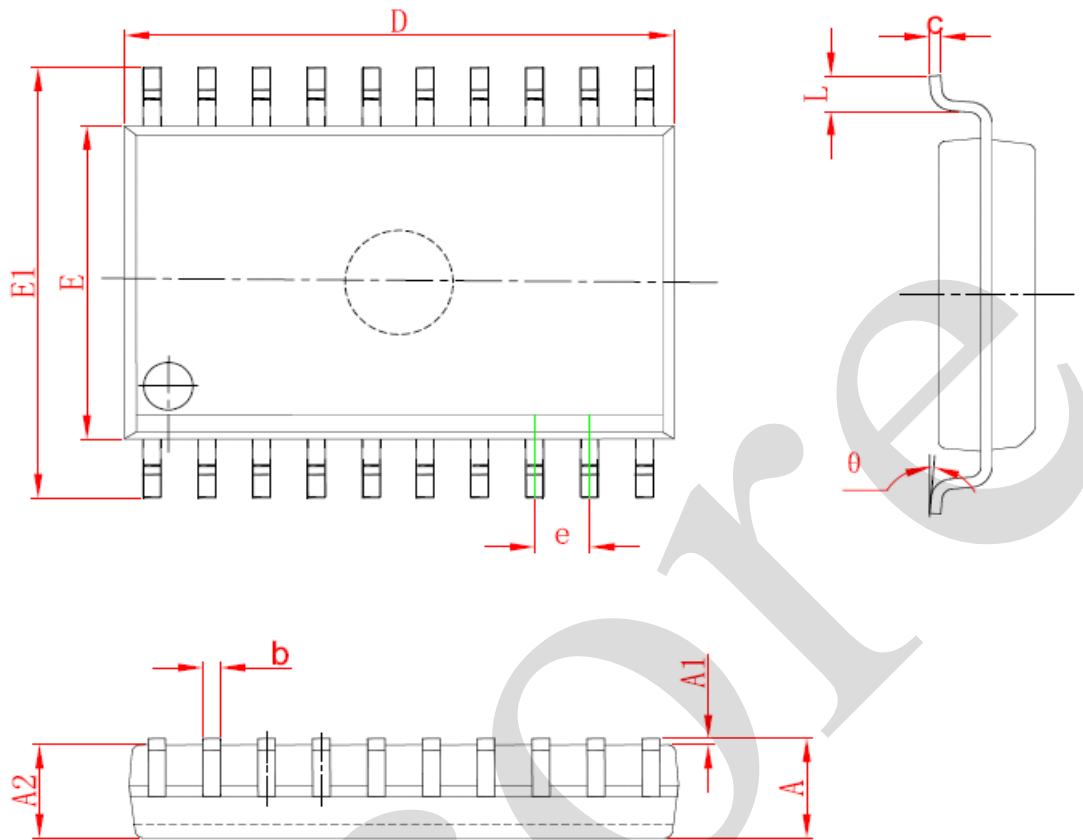

Symbol	Dimensions In Millimeters		Dimensions In Inches	
	Min	Max	Min	Max
A	2.350	2.650	0.093	0.104
A1	0.100	0.300	0.004	0.012
A2	2.100	2.500	0.083	0.098
b	0.330	0.510	0.013	0.020
c	0.204	0.330	0.008	0.013
D	12.520	13.000	0.493	0.512
E	7.400	7.600	0.291	0.299
E1	10.210	10.610	0.402	0.418
e	1.270 (BSC)		0.050 (BSC)	
L	0.400	1.270	0.016	0.050
θ	0°	8°	0°	8°



## 5.3. TSSOP20

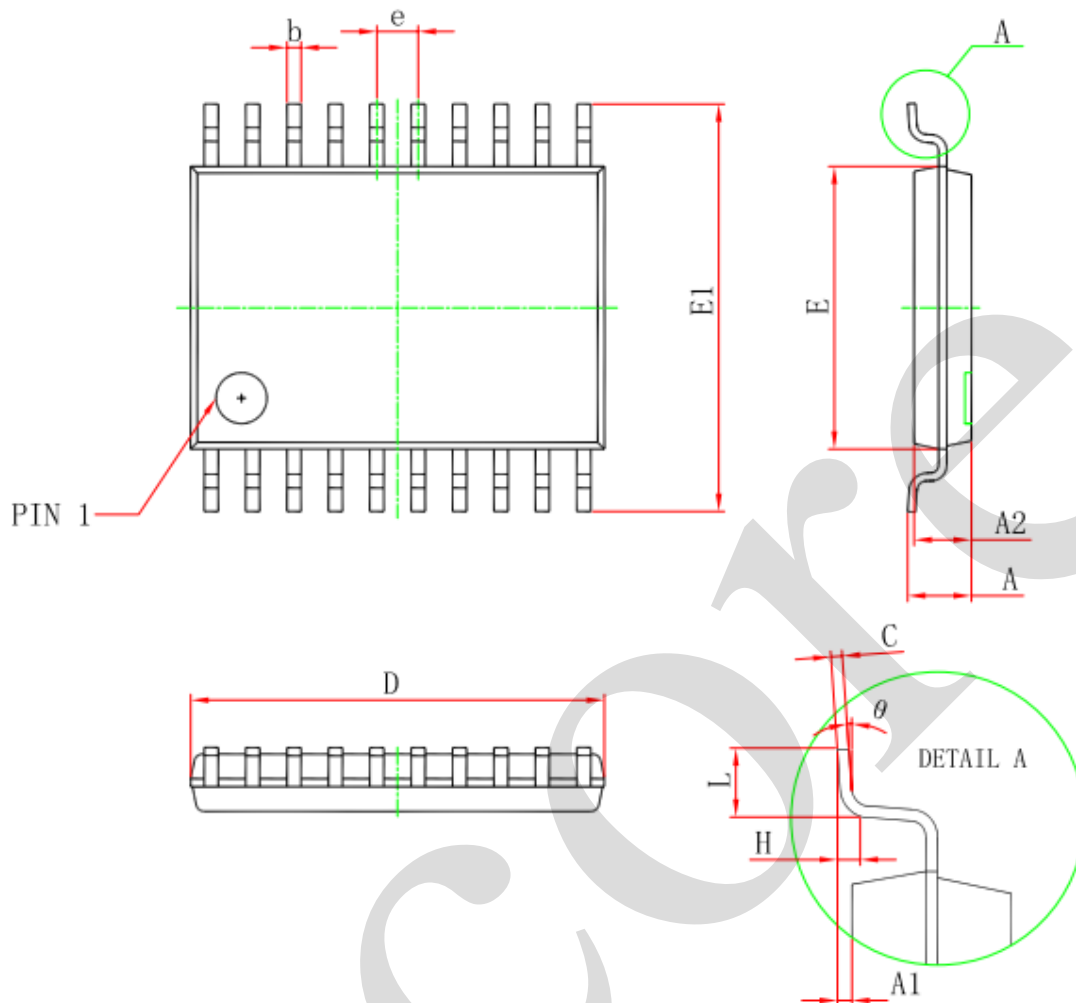

Symbol	Dimensions In Millimeters		Dimensions In Inches	
	Min	Max	Min	Max
D	6.400	6.600	0.252	0.259
E	4.300	4.500	0.169	0.177
b	0.190	0.300	0.007	0.012
e	0.090	0.200	0.004	0.008
E1	6.250	6.550	0.246	0.258
A		1.200		0.047
A2	0.800	1.000	0.031	0.039
A1	0.050	0.150	0.002	0.006
e	0.65 (BSC)		0.026 (BSC)	
L	0.500	0.700	0.020	0.028
H	0.25(TYP)		0.01(TYP)	
$\theta$	1°	7°	1°	7°



## 6、 Statements And Notes

### 6.1、 The name and content of Hazardous substances or Elements in the product

Part name	Hazardous substances or Elements									
	Lead and lead compounds	Mercury and mercury compounds	Cadmium and cadmium compounds	Hexavalent chromium compounds	Polybrominated biphenyls	Polybrominated biphenyl ethers	Dibutyl phthalate	Butylbenzyl phthalate	Di-2-ethylhexyl phthalate	Diisobutyl phthalate
Lead frame	○	○	○	○	○	○	○	○	○	○
Plastic resin	○	○	○	○	○	○	○	○	○	○
Chip	○	○	○	○	○	○	○	○	○	○
The lead	○	○	○	○	○	○	○	○	○	○
Plastic sheet installed	○	○	○	○	○	○	○	○	○	○
explanation	○: Indicates that the content of hazardous substances or elements in the detection limit of the following SJ/T11363-2006 standard. ×: Indicates that the content of hazardous substances or elements exceeding the SJ/T11363-2006 Standard limit requirements.									

### 6.2、 Notion

Recommended carefully reading this information before the use of this product;

The information in this document are subject to change without notice;

This information is using to the reference only, the company is not responsible for any loss;

The company is not responsible for the any infringement of the third party patents or other rights of the responsibility.



## X-ON Electronics

Largest Supplier of Electrical and Electronic Components

*Click to view similar products for [Buffers & Line Drivers](#) category:*

*Click to view products by [I-core](#) manufacturer:*

Other Similar products are found below :

[LXV200-024SW](#) [74AUP2G34FW3-7](#) [HEF4043BP](#) [NL17SG125DFT2G](#) [NLU1GT126CMUTCG](#) [CD4041UBE](#) [54FCT240CTDB](#)

[74HCT540N](#) [DS14C88N](#) [070519XB](#) [NL17SZ07P5T5G](#) [74LVC2G17FW4-7](#) [CD4502BE](#) [5962-8982101PA](#) [NL17SH17P5T5G](#)

[74HCT126T14-13](#) [74VHC9126FT\(BJ\)](#) [RHRXH162244K1](#) [74AUP1G34FW5-7](#) [74AUP1G07FW5-7](#) [74LVC1G126FW4-7](#)

[74LVC2G126RA3-7](#) [74LVCE1G125FZ4-7](#) [74AUP1G126FW5-7](#) [54FCT240TLB](#) [74LVCE1G07FZ4-7](#) [NLX3G16DMUTCG](#)

[NLX2G06AMUTCG](#) [LE87100NQCT](#) [LE87285NQC](#) [LE87290YQC](#) [LE87290YQCT](#) [74AUP1G125FW5-7](#) [NLU2G16CMUTCG](#)

[MC74LCX244MN2TWG](#) [NL17SG17P5T5G](#) [NLV74HC125ADR2G](#) [NLVHCT245ADTR2G](#) [NLVVHC1G126DFT2G](#) [EL5623IRZ](#)

[ISL15102AIRZ-T13](#) [ISL1539IRZ-T13](#) [MC100EP17MNG](#) [MC74HCT365ADR2G](#) [MC74LCX244ADTR2G](#) [NL27WZ126US](#) [NL37WZ16US](#)

[NLU1G07MUTCG](#) [NLU2G07MUTCG](#) [NLX3G17BMX1TCG](#)