



AiP74LVC138

3-to-8 Line Decoder/Demultiplexer; Inverting

Product Specification

Specification Revision History:

Version	Date	Description
2017-05-A1	2017-05	New
2021-08-A2	2021-08	Modify Supply Current Parameter
2021-12-A3	2021-12	Modify Ordering Information
2022-02-A4	2022-02	Modify ambient temperature to $-40^{\circ}\text{C}\sim+105^{\circ}\text{C}$ and add electrical characteristics of $-40^{\circ}\text{C}\sim+105^{\circ}\text{C}$



1、 General Description

The AiP74LVC138 is a 3-to-8 line decoder/demultiplexer. It accepts three binary weighted address inputs (A0, A1 and A2) and, when enabled, provides eight mutually exclusive outputs ($\bar{Y}0$ to $\bar{Y}7$) that are LOW when selected.

There are three enable inputs: two active LOW ($\bar{E}1$ and $\bar{E}2$) and one active HIGH (E3). Every output will be HIGH unless $\bar{E}1$ and $\bar{E}2$ are LOW and E3 is HIGH.

This multiple enable function allows easy parallel expansion of the device to a 1-of-32 (5 lines to 32 lines) decoder with just four AiP74LVC138 devices and one inverter. The AiP74LVC138 can be used as an eight output demultiplexer by using one of the active LOW enable inputs as the data input and the remaining enable inputs as strobes. Unused enable inputs must be permanently tied to their appropriate active HIGH or LOW state.

Features:

- 5V tolerant inputs/outputs for interfacing with 5V logic
- Wide supply voltage range from 1.2V to 3.6V
- CMOS low power consumption
- Direct interface with TTL levels
- Demultiplexing capability
- Multiple input enable for easy expansion
- Ideal for memory chip select decoding
- Mutually exclusive outputs
- Specified from -40°C to +105°C
- Packaging information: DIP16/SOP16/TSSOP16/DHVQFN16

**Ordering Information:****Tube packing specifications:**

Part number	Packaging form	Marking code	Tube quantity	Boxed tube quantity	Boxed quantity	Notes
AiP74LVC138DA16.TB	DIP16	74LVC138	25 PCS/tube	40 tube/box	1000 PCS/box	Dimensions of plastic enclosure: 19.0mm×6.4mm Pin spacing: 2.54mm
AiP74LVC138SA16.TB	SOP16	74LVC138	50 PCS/tube	200 tube/box	10000 PCS/box	Dimensions of plastic enclosure: 10.0mm×3.9mm Pin spacing: 1.27mm
AiP74LVC138TA16.TB	TSSOP16	74LVC138	96 PCS/tube	200 tube/box	19200 PCS/box	Dimensions of plastic enclosure: 5.0mm×4.4mm Pin spacing: 0.65mm

Reel packing specifications:

Part number	Packaging form	Marking code	Reel quantity	Boxed reel quantity	Notes
AiP74LVC138SA16.TR	SOP16(1)	74LVC138	2500 PCS/reel	5000 PCS/box	Dimensions of plastic enclosure: 10.0mm×3.9mm Pin spacing:1.27mm
AiP74LVC138SA16.TR	SOP16(2)	74LVC138	2500 PCS/reel	2500 PCS/box	Dimensions of plastic enclosure: 10.0mm×3.9mm Pin spacing:1.27mm
AiP74LVC138TA16.TR	TSSOP16	74LVC138	2500 PCS/reel	5000 PCS/box	Dimensions of plastic enclosure: 5.0mm×4.4mm Pin spacing:0.65mm
AiP74LVC138QE16.TR	DHVQFN16	74LVC138	3000 PCS/reel	3000 PCS/box	Dimensions of plastic enclosure: 3.5mm×2.5mm Pin spacing: 0.5mm

Note: If the physical information is inconsistent with the ordering information, please refer to the actual product.



2、Block Diagram And Pin Description

2.1、Block Diagram

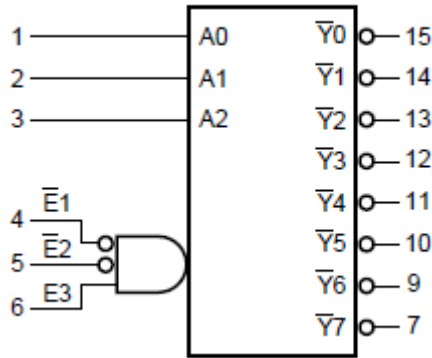

Figure 1. Logic symbol

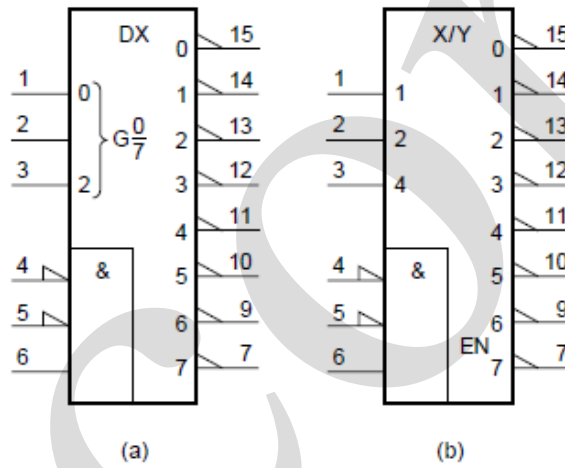

Figure 2. IEC logic symbol

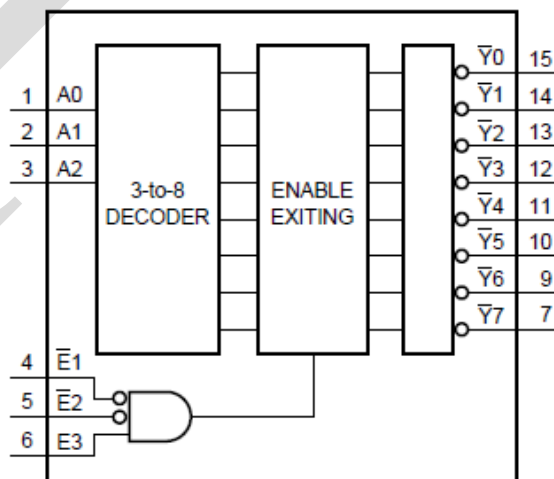
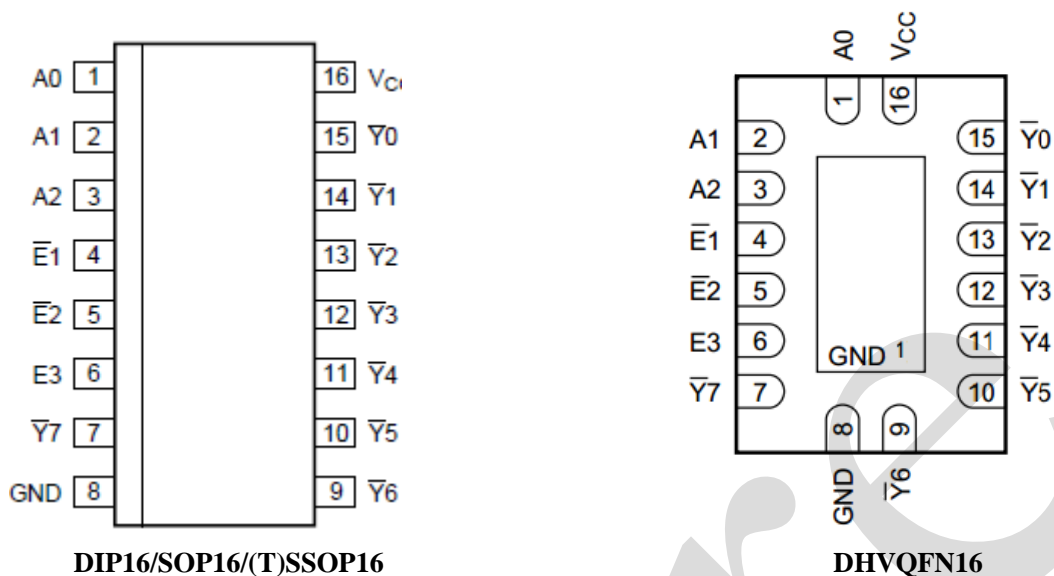

Figure 3. Functional diagram



2.2、Pin Configurations



Note:

1. This is not a supply pin. The substrate is attached to this pad using conductive die attach material. There is no electrical or mechanical requirement to solder this pad. However, if it is soldered, the solder land should remain floating or be connected to GND.

2.3、Pin Description

Pin No.	Pin Name	Description
1	A0	address input
2	A1	address input
3	A2	address input
4	$\bar{E}1$	enable input (active LOW)
5	$\bar{E}2$	enable input (active LOW)
6	E3	enable input (active HIGH)
7	$\bar{Y}7$	output
8	GND	ground (0V)
9	$\bar{Y}6$	output
10	$\bar{Y}5$	output
11	$\bar{Y}4$	output
12	$\bar{Y}3$	output
13	$\bar{Y}2$	output
14	$\bar{Y}1$	output
15	$\bar{Y}0$	output
16	V _{CC}	supply voltage



2.4、Function Table

Input						Output							
$\bar{E}1$	$\bar{E}2$	E3	A0	A1	A2	$\bar{Y}0$	$\bar{Y}1$	$\bar{Y}2$	$\bar{Y}3$	$\bar{Y}4$	$\bar{Y}5$	$\bar{Y}6$	$\bar{Y}7$
H	X	X	X	X	X	H	H	H	H	H	H	H	H
X	H	X	X	X	X	H	H	H	H	H	H	H	H
X	X	L	X	X	X	H	H	H	H	H	H	H	H
L	L	H	L	L	L	L	H	H	H	H	H	H	H
L	L	H	H	L	L	H	L	H	H	H	H	H	H
L	L	H	L	H	L	H	H	L	H	H	H	H	H
L	L	H	H	H	L	H	H	H	L	H	H	H	H
L	L	H	L	L	H	H	H	H	H	L	H	H	H
L	L	H	H	L	H	H	H	H	H	H	L	H	H
L	L	H	L	H	H	H	H	H	H	H	H	L	H
L	L	H	H	H	H	H	H	H	H	H	H	H	L

Note: H=HIGH voltage level; L=LOW voltage level; X=don't care.

3、Electrical Parameter

3.1、Absolute Maximum Ratings

(Voltages are referenced to GND(ground=0V), unless otherwise specified.)

Parameter	Symbol	Conditions	Min.	Max.	Unit
supply voltage	V_{CC}	-	-0.5	+6.5	V
input clamping current	I_{IK}	$V_I < 0V$	-50	-	mA
input voltage	V_I	-	-0.5	+6.5	V
output clamping current	I_{OK}	$V_O > V_{CC}$ or $V_O < 0V$	-	± 50	mA
output voltage	V_O	output HIGH or LOW state	-0.5	$V_{CC}+0.5$	V
output current	I_O	$V_O=0V$ to V_{CC}	-	± 50	mA
supply current	I_{CC}	-	-	100	mA
ground current	I_{GND}	-	-100	-	mA
total power dissipation	P_{tot}	-	-	500	mW
storage temperature	T_{stg}	-	-65	+150	°C
Soldering Temperature	T_L	10s	DIP	245	°C
			SOP	250	°C
			DHVQFN	250	°C

Note:

- [1] For DIP16 packages: above 70°C the value of P_{tot} derates linearly with 12mW/K.
- [2] For SOP16 packages: above 70°C the value of P_{tot} derates linearly with 8mW/K.
- [3] For (T)SSOP16 packages: above 60°C the value of P_{tot} derates linearly with 5.5mW/K.
- [4] For DHVQFN16 packages: above 60°C the value of P_{tot} derates linearly with 4.5mW/K.



3.2、Recommended Operating Conditions

Parameter	Symbol	Conditions	Min.	Typ.	Max.	Unit
supply voltage	V_{CC}	-	1.65	-	3.6	V
		functional	1.2	-	-	V
input voltage	V_I	-	0	-	5.5	V
output voltage	V_O	output HIGH or LOW-state	0	-	V_{CC}	V
ambient temperature	T_{amb}	-	-40	-	+105	°C
input transition rise and fall rate	$\Delta t/\Delta V$	$V_{CC}=1.65V$ to $2.7V$	0	-	20	ns/V
		$V_{CC}=2.7V$ to $3.6V$	0	-	10	ns/V

3.3、Electrical Characteristics

3.3.1、DC Characteristics 1

($T_{amb}=-40^{\circ}C$ to $+85^{\circ}C$, voltages are referenced to GND (ground=0V), unless otherwise specified.)

Parameter	Symbol	Conditions	Min.	Typ.	Max.	Unit	
HIGH-level input voltage	V_{IH}	$V_{CC}=1.2V$	1.08	-	-	V	
		$V_{CC}=1.65V$ to $1.95V$	$0.65 \times V_{CC}$	-	-	V	
		$V_{CC}=2.3V$ to $2.7V$	1.7	-	-	V	
		$V_{CC}=2.7V$ to $3.6V$	2.0	-	-	V	
LOW-level input voltage	V_{IL}	$V_{CC}=1.2V$	-	-	0.12	V	
		$V_{CC}=1.65V$ to $1.95V$	-	-	$0.35 \times V_{CC}$	V	
		$V_{CC}=2.3V$ to $2.7V$	-	-	0.7	V	
		$V_{CC}=2.7V$ to $3.6V$	-	-	0.8	V	
HIGH-level output voltage	V_{OH}	$V_I = V_{IH}$ or V_{IL}	$I_O=-100\mu A$; $V_{CC}=1.65V$ to $3.6V$	$V_{CC} - 0.2$	-	-	V
			$I_O=-4mA$; $V_{CC}=1.65V$	1.2	-	-	V
			$I_O=-8mA$; $V_{CC}=2.3V$	1.8	-	-	V
			$I_O=-12mA$; $V_{CC}=2.7V$	2.2	-	-	V
			$I_O=-18mA$; $V_{CC}=3.0V$	2.4	-	-	V
			$I_O=-24mA$; $V_{CC}=3.0V$	2.2	-	-	V
LOW-level output voltage	V_{OL}	$V_I = V_{IH}$ or V_{IL}	$I_O=100\mu A$; $V_{CC}=1.65V$ to $3.6V$	-	-	0.2	V
			$I_O=4mA$; $V_{CC}=1.65V$	-	-	0.45	V
			$I_O=8mA$; $V_{CC}=2.3V$	-	-	0.6	V
			$I_O=12mA$; $V_{CC}=2.7V$	-	-	0.4	V
			$I_O=24mA$; $V_{CC}=3.0V$	-	-	0.55	V
input leakage current	I_I	$V_I=5.5V$ or GND; $V_{CC}=3.6V$	-	± 0.1	± 5	μA	
supply current	I_{CC}	$V_I=V_{CC}$ or GND; $I_O=0A$; $V_{CC}=3.6V$	-	1.5	15	μA	
additional supply current	ΔI_{CC}	per input pin; $V_I=V_{CC}-0.6V$; $I_O=0A$; $V_{CC}=2.7V$ to $3.6V$	-	5	500	μA	
input capacitance	C_I	$V_{CC}=0V$ to $3.6V$; $V_I=$ GND to V_{CC}	-	4.0	-	pF	

Note: All typical values are measured at $V_{CC}=3.3V$ (unless stated otherwise) and $T_{amb}=25^{\circ}C$.



3.3.2、DC Characteristics 2

($T_{amb}=-40^{\circ}\text{C}$ to $+105^{\circ}\text{C}$, voltages are referenced to GND (ground=0V), unless otherwise specified.)

Parameter	Symbol	Conditions	Min.	Typ.	Max.	Unit	
HIGH-level input voltage	V_{IH}	$V_{CC}=1.2\text{V}$	1.08	-	-	V	
		$V_{CC}=1.65\text{V}$ to 1.95V	$0.65 \times V_{CC}$	-	-	V	
		$V_{CC}=2.3\text{V}$ to 2.7V	1.7	-	-	V	
		$V_{CC}=2.7\text{V}$ to 3.6V	2.0	-	-	V	
LOW-level input voltage	V_{IL}	$V_{CC}=1.2\text{V}$	-	-	0.12	V	
		$V_{CC}=1.65\text{V}$ to 1.95V	-	-	$0.35 \times V_{CC}$	V	
		$V_{CC}=2.3\text{V}$ to 2.7V	-	-	0.7	V	
		$V_{CC}=2.7\text{V}$ to 3.6V	-	-	0.8	V	
HIGH-level output voltage	V_{OH}	$V_I = V_{IH}$ or V_{IL}	$I_O=-100\mu\text{A}; V_{CC}=1.65\text{V}$ to 3.6V	$V_{CC} - 0.3$	-	-	V
			$I_O=-4\text{mA}; V_{CC}=1.65\text{V}$	1.05	-	-	V
			$I_O=-8\text{mA}; V_{CC}=2.3\text{V}$	1.65	-	-	V
			$I_O=-12\text{mA}; V_{CC}=2.7\text{V}$	2.05	-	-	V
			$I_O=-18\text{mA}; V_{CC}=3.0\text{V}$	2.25	-	-	V
			$I_O=-24\text{mA}; V_{CC}=3.0\text{V}$	2.0	-	-	V
LOW-level output voltage	V_{OL}	$V_I = V_{IH}$ or V_{IL}	$I_O=100\mu\text{A}; V_{CC}=1.65\text{V}$ to 3.6V	-	-	0.3	V
			$I_O=4\text{mA}; V_{CC}=1.65\text{V}$	-	-	0.65	V
			$I_O=8\text{mA}; V_{CC}=2.3\text{V}$	-	-	0.8	V
			$I_O=12\text{mA}; V_{CC}=2.7\text{V}$	-	-	0.6	V
			$I_O=24\text{mA}; V_{CC}=3.0\text{V}$	-	-	0.8	V
input leakage current	I_I	$V_I=5.5\text{V}$ or GND; $V_{CC}=3.6\text{V}$	-	-	± 20	μA	
supply current	I_{CC}	$V_I=V_{CC}$ or GND; $I_O=0\text{A}; V_{CC}=3.6\text{V}$	-	-	40	μA	
additional supply current	ΔI_{CC}	per input pin; $V_I=V_{CC}-0.6\text{V}; I_O=0\text{A}; V_{CC}=2.7\text{V}$ to 3.6V	-	-	5000	μA	

Note: All typical values are measured at $V_{CC}=3.3\text{V}$ (unless stated otherwise) and $T_{amb}=25^{\circ}\text{C}$.



3.3.3. AC Characteristics 1

($T_{amb} = -40^{\circ}\text{C}$ to $+85^{\circ}\text{C}$, voltages are referenced to GND (ground=0V), unless otherwise specified.)

Parameter	Symbol	Conditions	Min.	Typ.	Max.	Unit	
propagation delay	t_{pd}	An to \bar{Y}_n see Figure 5	$V_{CC}=1.2\text{V}$	-	14	-	ns
			$V_{CC}=1.65\text{V to }1.95\text{V}$	0.5	5.2	11.5	ns
			$V_{CC}=2.3\text{V to }2.7\text{V}$	1.5	3.0	6.5	ns
			$V_{CC}=2.7\text{V}$	1.5	3.2	6.8	ns
			$V_{CC}=3.0\text{V to }3.6\text{V}$	1.0	2.7	5.8	ns
		E3 to \bar{Y}_n see Figure 5	$V_{CC}=1.2\text{V}$	-	14	-	ns
			$V_{CC}=1.65\text{V to }1.95\text{V}$	1.0	5.5	11.4	ns
			$V_{CC}=2.3\text{V to }2.7\text{V}$	1.5	3.2	6.5	ns
			$V_{CC}=2.7\text{V}$	1.5	3.3	6.8	ns
			$V_{CC}=3.0\text{V to }3.6\text{V}$	1.0	2.9	5.8	ns
		\bar{E}_n to \bar{Y}_n see Figure 6	$V_{CC}=1.2\text{V}$	-	15	-	ns
			$V_{CC}=1.65\text{V to }1.95\text{V}$	1.0	5.6	11.5	ns
			$V_{CC}=2.3\text{V to }2.7\text{V}$	1.8	3.3	6.5	ns
			$V_{CC}=2.7\text{V}$	1.5	3.4	6.4	ns
			$V_{CC}=3.0\text{V to }3.6\text{V}$	1.0	2.9	5.8	ns
output skew time	$t_{sk(o)}$	-	-	-	1.0	ns	
Power dissipation capacitance	C_{PD}	$V_I = \text{GND to } V_{CC}$	$V_{CC}=1.65\text{V to }1.95\text{V}$	-	9.9	-	pF
			$V_{CC}=2.3\text{V to }2.7\text{V}$	-	15.8	-	pF
			$V_{CC}=3.0\text{V to }3.6\text{V}$	-	21.1	-	pF

Note:

[1] Typical values are measured at $T_{amb} = 25^{\circ}\text{C}$ and $V_{CC} = 1.2\text{V}, 1.8\text{V}, 2.5\text{V}, 2.7\text{V}$ and 3.3V respectively.

[2] t_{pd} is the same as t_{PLH} and t_{PHL} .

[3] Skew between any two outputs of the same package switching in the same direction. This parameter is guaranteed by design.

[4] C_{PD} is used to determine the dynamic power dissipation (P_D in uW).

$$P_D = C_{PD} \times V_{CC}^2 \times f_i \times N + \sum(C_L \times V_{CC}^2 \times f_o) \text{ where:}$$

f_i = input frequency in MHz;

f_o = output frequency in MHz;

C_L = output load capacitance in pF;

V_{CC} = supply voltage in V;

N = number of inputs switching;

$\sum(C_L \times V_{CC}^2 \times f_o)$ = sum of outputs.



3.3.4. AC Characteristics 2

($T_{amb}=-40^{\circ}\text{C}$ to $+105^{\circ}\text{C}$, voltages are referenced to GND (ground=0V), unless otherwise specified.)

Parameter	Symbol	Conditions	Min.	Typ.	Max.	Unit	
propagation delay	t_{pd}	An to \bar{Y}_n see Figure 5	$V_{CC}=1.65\text{V}$ to 1.95V	0.5	-	12.7	ns
			$V_{CC}=2.3\text{V}$ to 2.7V	1.5	-	7.3	ns
			$V_{CC}=2.7\text{V}$	1.5	-	8.5	ns
			$V_{CC}=3.0\text{V}$ to 3.6V	1.0	-	7.5	ns
		E3 to \bar{Y}_n see Figure 5	$V_{CC}=1.65\text{V}$ to 1.95V	1.0	-	12.5	ns
			$V_{CC}=2.3\text{V}$ to 2.7V	1.5	-	7.1	ns
			$V_{CC}=2.7\text{V}$	1.5	-	8.5	ns
			$V_{CC}=3.0\text{V}$ to 3.6V	1.0	-	7.5	ns
		\bar{E}_n to \bar{Y}_n see Figure 6	$V_{CC}=1.65\text{V}$ to 1.95V	1.0	-	12.8	ns
			$V_{CC}=2.3\text{V}$ to 2.7V	1.8	-	7.3	ns
			$V_{CC}=2.7\text{V}$	1.5	-	8.0	ns
			$V_{CC}=3.0\text{V}$ to 3.6V	1.0	-	7.5	ns
output skew time	$t_{sk(o)}$	-	-	-	1.5	ns	

Note:

[1] Typical values are measured at $T_{amb}=25^{\circ}\text{C}$ and $V_{CC}=1.2\text{V}$, 1.8V , 2.5V , 2.7V and 3.3V respectively.

[2] t_{pd} is the same as t_{PLH} and t_{PHL} .

[3] Skew between any two outputs of the same package switching in the same direction. This parameter is guaranteed by design.

4. Testing Circuit

4.1. AC Testing Circuit

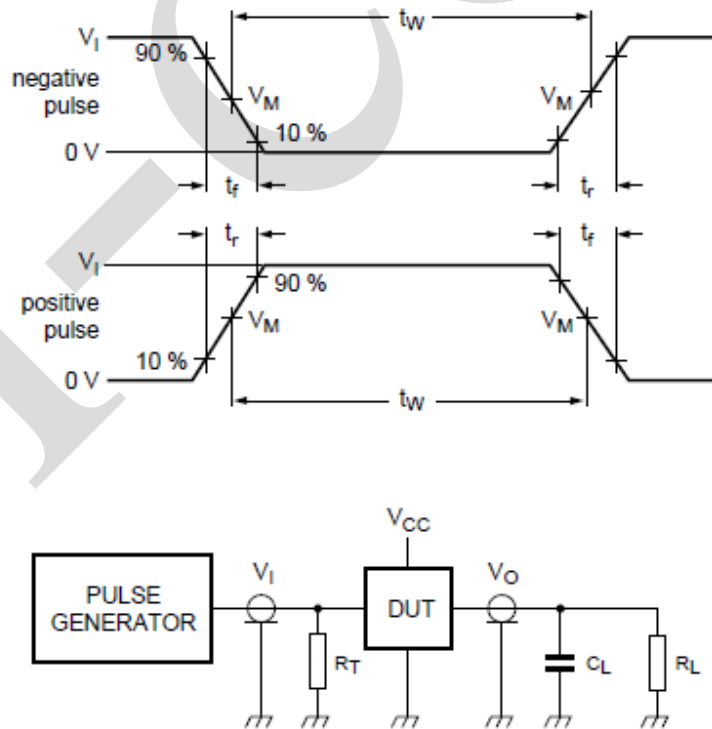

Figure 4. Test circuit for measuring switching times



Definitions for test circuit:

R_L =Load resistance.

C_L =Load capacitance including jig and probe capacitance.

R_T =Termination resistance should be equal to the output impedance Z_o of the pulse generator.

4.2、 AC Testing Waveforms

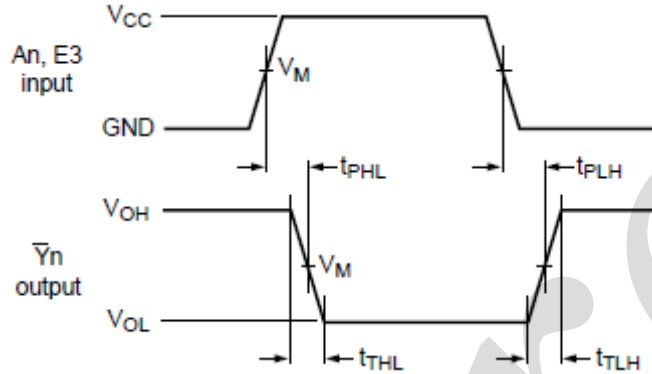

Figure 5. The inputs A_n, E_3 to outputs \bar{Y}_n propagation delays

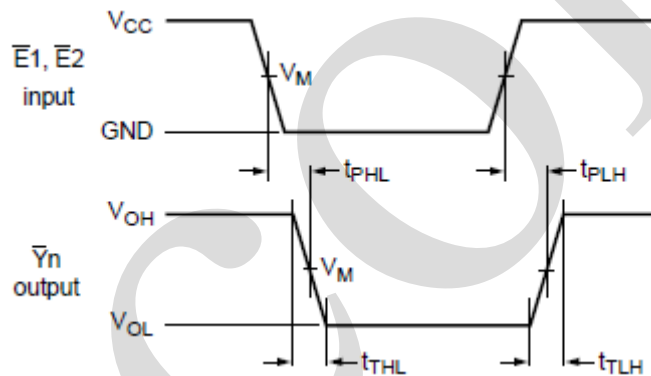

Figure 6. The inputs \bar{E}_n to outputs \bar{Y}_n propagation delays

4.3、 Measurement Points

Supply voltage	Input	Output
V_{CC}	V_M	V_M
$< 2.7V$	$0.5 \times V_{CC}$	$0.5 \times V_{CC}$
$\geq 2.7V$	1.5V	1.5V

4.4、 Test Data

Supply voltage	Input		Load	
V_{CC}	V_I	t_r, t_f	C_L	R_L
1.2V	V_{CC}	$\leq 2.0ns$	30pF	1k Ω
1.65V to 1.95V	V_{CC}	$\leq 2.0ns$	30pF	1k Ω
2.3V to 2.7V	V_{CC}	$\leq 2.0ns$	30pF	500 Ω
2.7V	2.7V	$\leq 2.5ns$	50pF	500 Ω
3.0V to 3.6V	2.7V	$\leq 2.5ns$	50pF	500 Ω



5、 Package Information

5.1、 DIP16

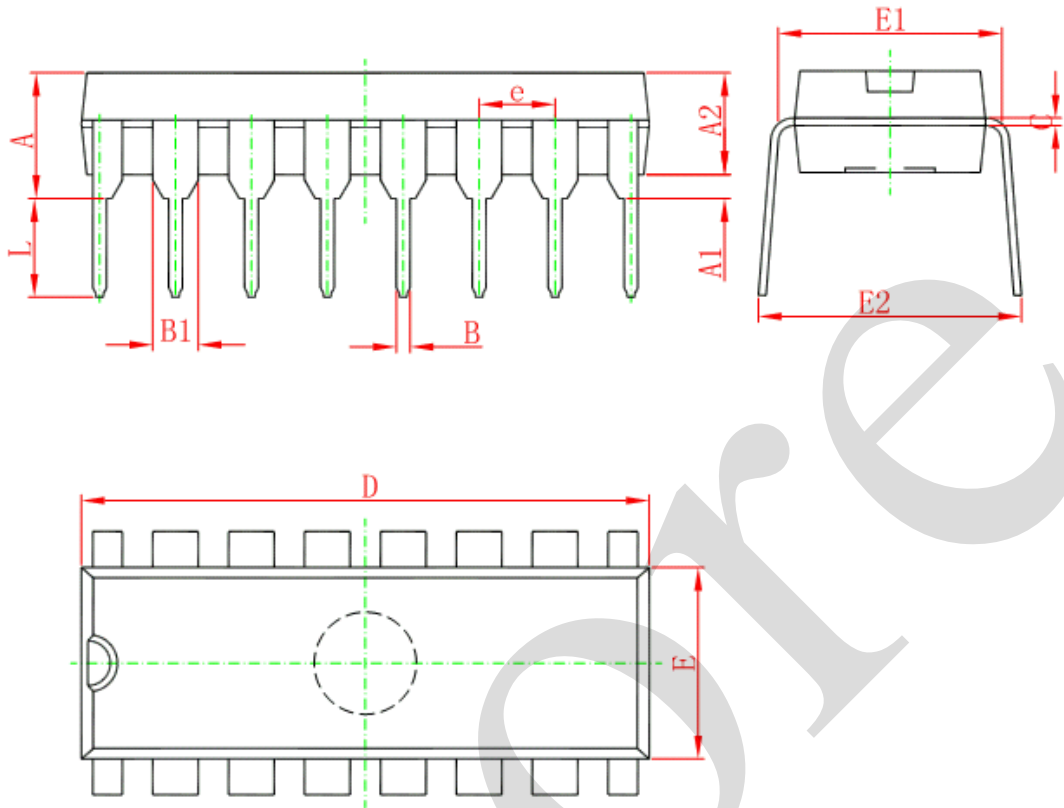

Symbol	Dimensions In Millimeters		Dimensions In Inches	
	Min	Max	Min	Max
A	3.710	4.310	0.146	0.170
A1	0.510		0.020	
A2	3.200	3.600	0.126	0.142
B	0.380	0.570	0.015	0.022
B1	1.524 (BSC)		0.060 (BSC)	
C	0.204	0.360	0.008	0.014
D	18.800	19.200	0.740	0.756
E	6.200	6.600	0.244	0.260
E1	7.320	7.920	0.288	0.312
e	2.540 (BSC)		0.100 (BSC)	
L	3.000	3.600	0.118	0.142
E2	8.400	9.000	0.331	0.354



5.2、SOP16

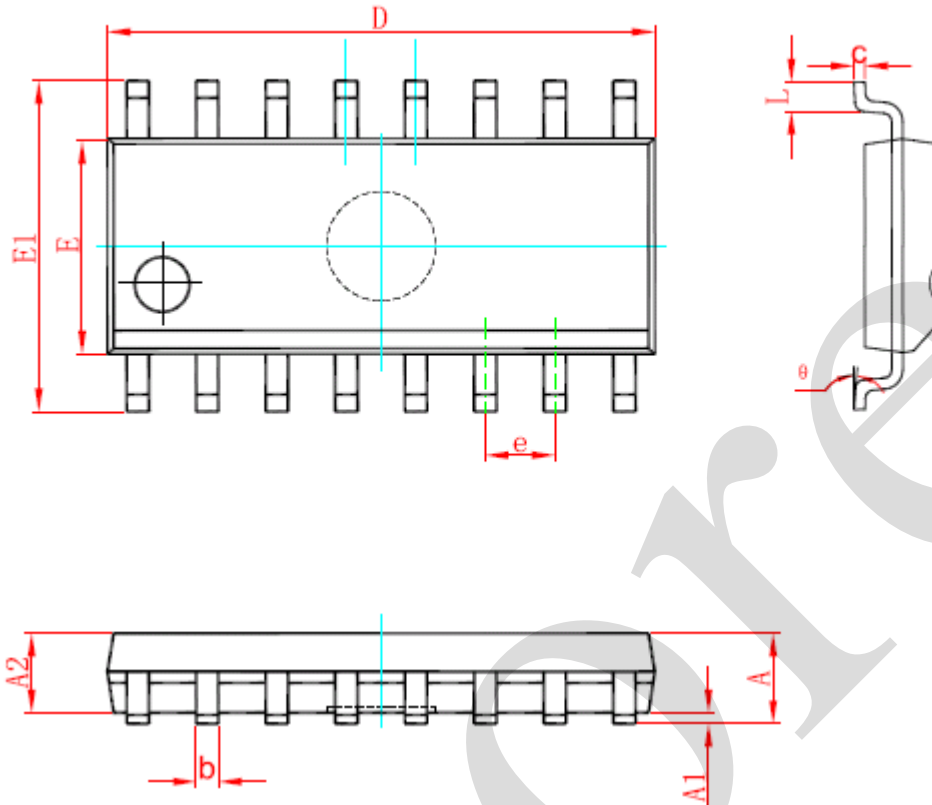

Symbol	Dimensions In Millimeters		Dimensions In Inches	
	Min	Max	Min	Max
A	1.350	1.750	0.053	0.069
A1	0.100	0.250	0.004	0.010
A2	1.350	1.550	0.053	0.061
b	0.330	0.510	0.013	0.020
c	0.170	0.250	0.007	0.010
D	9.800	10.200	0.386	0.402
E	3.800	4.000	0.150	0.157
E1	5.800	6.200	0.228	0.244
e	1.270 (BSC)		0.050 (BSC)	
L	0.400	1.270	0.016	0.050
θ	0°	8°	0°	8°



5.3、TSSOP16

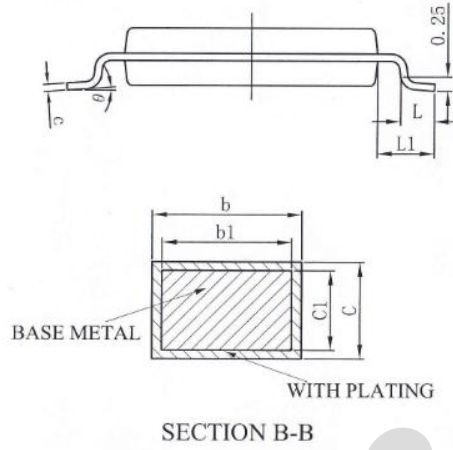
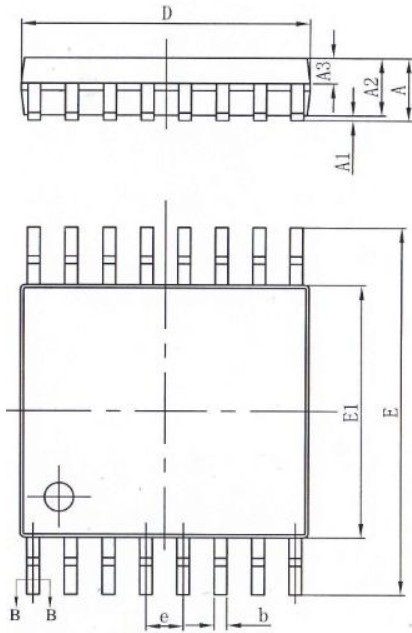

SYMBOL	MILLIMETER		
	MIN	NOM	MAX
A	—	—	1.20
A1	0.05	—	0.15
A2	0.90	1.00	1.05
A3	0.39	0.44	0.49
b	0.20	—	0.28
b1	0.19	0.22	0.25
c	0.13	—	0.17
c1	0.12	0.13	0.14
D	4.90	5.00	5.10
E	6.20	6.40	6.60
E1	4.30	4.40	4.50
e	0.65BSC		
L	0.45	0.60	0.75
L1	1.00BSC		
θ	0	—	8°



5.4. DHVQFN16

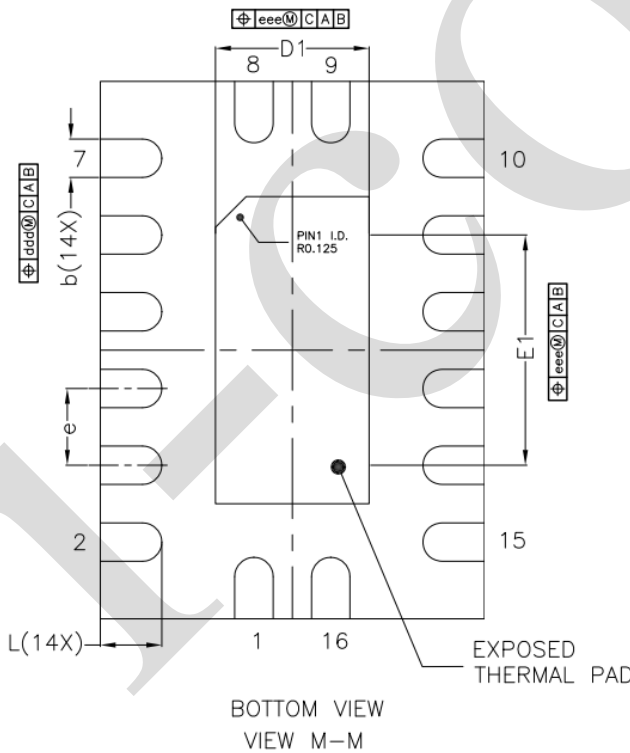
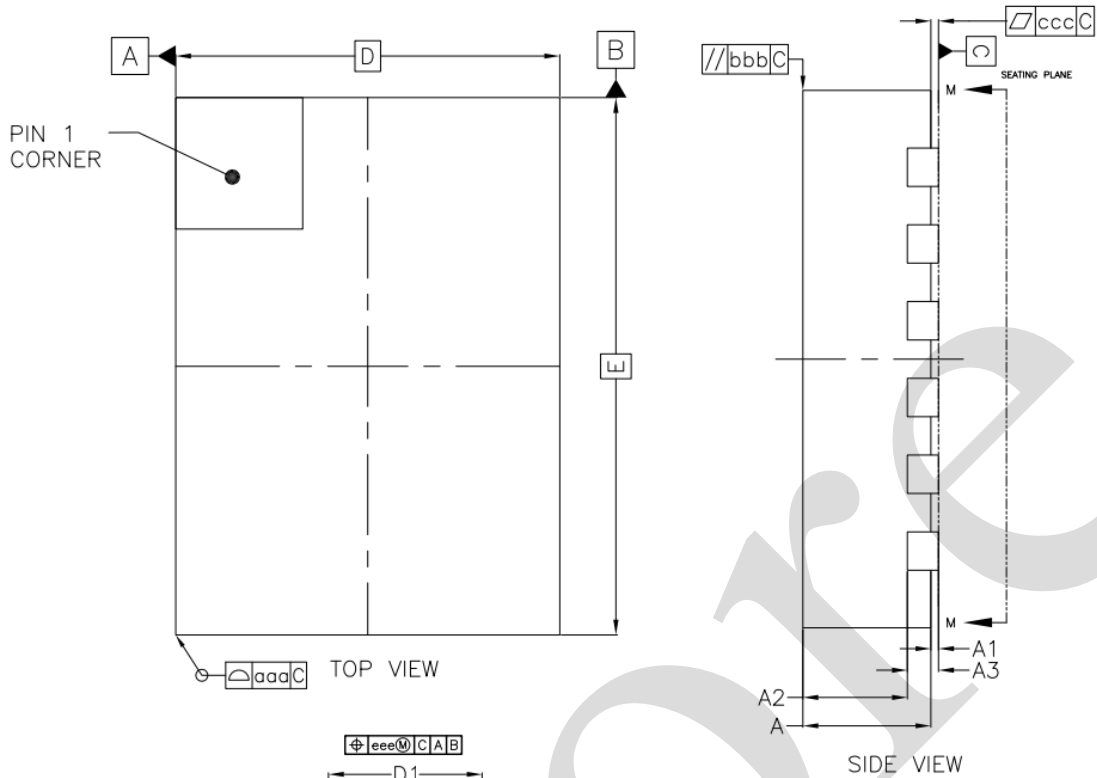

DESCRIPTION	SYMBOL	MILLIMETER			
		MIN	NOM	MAX	
TOTAL THICKNESS	A	0.80	0.85	1.00	
STAND OFF	A1	0.00	--	0.05	
MOLD THICKNESS	A2	0.60	0.65	0.70	
L/F THICKNESS	A3	0.203 REF			
BODY SIZE	X	D	2.40	2.50	2.60
	Y	E	3.40	3.50	3.60
LEAD PITCH	e	0.50 BSC			
LEAD WIDTH	b	0.18	0.25	0.30	
LEAD LENGTH	L	0.30	0.40	0.50	
EP SIZE	D1	0.85	1.00	1.15	
	E1	1.85	2.00	2.15	
Tolerance of form and position					
PKG EDGE TOLERANCE	aaa	0.1			
MOLD FLATNESS	bbb	0.1			
COPLANARITY	ccc	0.05			
LEAD OFFSET	ddd	0.1			
EXPOSED PAD OFFSET	eee	0.1			

NOTES
 1.0 COPLANARITY APPLIES TO LEADS, CORNER LEADS AND DIE ATTACH PAD.



6、 Statements And Notes

6.1、 The name and content of Hazardous substances or Elements in the product

Part name	Hazardous substances or Elements									
	Lead and lead compounds	Mercury and mercury compounds	Cadmium and cadmium compounds	Hexavalent chromium compounds	Polybrominated biphenyls	Polybrominated biphenyl ethers	Dibutyl phthalate	Butylbenzyl phthalate	Di-2-ethylhexyl phthalate	Diisobutyl phthalate
Lead frame	○	○	○	○	○	○	○	○	○	○
Plastic resin	○	○	○	○	○	○	○	○	○	○
Chip	○	○	○	○	○	○	○	○	○	○
The lead	○	○	○	○	○	○	○	○	○	○
Plastic sheet installed	○	○	○	○	○	○	○	○	○	○
explanation	○: Indicates that the content of hazardous substances or elements in the detection limit of the following the SJ/T11363-2006 standard ×: Indicates that the content of hazardous substances or elements exceeding the SJ/T11363-2006 Standard limit requirements.									

6.2、 Notion

Recommended carefully reading this information before the use of this product;

The information in this document are subject to change without notice;

This information is using to the reference only, the company is not responsible for any loss;

The company is not responsible for the any infringement of the third party patents or other rights of the responsibility.

X-ON Electronics

Largest Supplier of Electrical and Electronic Components

Click to view similar products for [Encoders, Decoders, Multiplexers & Demultiplexers](#) category:

Click to view products by [I-core](#) manufacturer:

Other Similar products are found below :

[MC74HC163ADTG](#) [74HC253N](#) [NLV74VHC1G01DFT1G](#) [NLVHCT4851ADTR2G](#) [NLV14028BDR2G](#) [COMX-CAR-210](#) [SN74LS148N](#)
[PI3B3251LE](#) [PI3B3251QE](#) [NLV74HC4851AMNTWG](#) [MC74LVX257DG](#) [M74HCT4851ADWR2G](#) [NL7SZ19DBVT1G](#) [PI5C3253LEX](#)
[MC74ACT138NG](#) [NB3L8533DTR2G](#) [NLV74AC157DR2G](#) [74HC138DT](#) [74HC153DT](#) [74HC238DT](#) [74HC151DT](#) [ADS131M02IRUKR](#)
[CBMG709ATS16](#) [74HC238N](#) [HT74HC154ARWZ](#) [RS2G139XS16-G](#) [74HCT251D](#) [74HC138T](#) [U74HC138G-S16-R](#) [AIP74HCT138SA.TB](#)
[XD74C922](#) [SN74LVC1G19DBVR\(UMW\)](#) [RS1G157XC6](#) [74HC151M/TR](#) [AiP74HC237TA16.TB](#) [AIP74HC138TA16.TB](#) [74HC138DRG](#)
[AiP74LVC138TA16.TB](#) [CD4511BDRG](#) [AiP74LVC157TA16.TB](#) [SN74HC42N\(LX\)](#) [SN74LS157N\(LX\)](#) [SN74LS42N](#) [QS3VH251QG8](#)
[MC74HC151ADTG](#) [MC74LVX257DTR2G](#) [74VHC238FT\(BJ\)](#) [74VHC4066AFT\(BJ\)](#) [74VHCT138AFT\(BJ\)](#) [NC7SZ157P6X](#)