



AiP74LVC/LVCH1T45

Dual Supply Translating Transceiver;

3-State

Product Specification

Specification Revision History:

Version	Date	Description
2017-04-A1	2017-04	New
2021-10-A2	2021-10	Modify ordering information
2021-12-A3	2021-12	Modify ordering information
2022-03-A4	2022-03	Modify ordering information note 1



1、 General Description

The AiP74LVC1T45; AiP74LVCH1T45 are single bit, dual supply transceivers with 3-state outputs that enable bidirectional level translation. They feature two 1-bit input-output ports (A and B), a direction control input (DIR) and dual supply pins ($V_{CC(A)}$ and $V_{CC(B)}$). Both $V_{CC(A)}$ and $V_{CC(B)}$ can be supplied at any voltage between 1.2 V and 5.5 V making the device suitable for translating between any of the low voltage nodes (1.2V, 1.5V, 1.8V, 2.5V, 3.3V and 5.0V). Pins A and DIR are referenced to $V_{CC(A)}$ and pin B is referenced to $V_{CC(B)}$. A HIGH on DIR allows transmission from A to B and a LOW on DIR allows transmission from B to A.

The devices are fully specified for partial power-down applications using I_{OFF} . The I_{OFF} circuitry disables the output, preventing any damaging backflow current through the device when it is powered down. In suspend mode when either $V_{CC(A)}$ or $V_{CC(B)}$ are at GND level, both A port and B port are in the high-impedance OFF-state.

Active bus hold circuitry in the AiP74LVCH1T45 holds unused or floating data inputs at a valid logic level.

Features:

- Wide supply voltage range:
 $V_{CC(A)}$: 1.2V to 5.5V
 $V_{CC(B)}$: 1.2V to 5.5V
- Maximum data rates:
420 Mbps (3.3V to 5.0V translation)
210 Mbps (translate to 3.3V)
140 Mbps (translate to 2.5V)
75 Mbps (translate to 1.8V)
60 Mbps (translate to 1.5V)
- Suspend mode
- $\pm 24\text{mA}$ output drive ($V_{CC}=3.0\text{V}$)
- Inputs accept voltages up to 5.5V
- Low power consumption: 16 μA maximum I_{CC}
- I_{OFF} circuitry provides partial Power-down mode operation
- Specified from -40°C to $+105^{\circ}\text{C}$
- Packaging information: SOT23-6/SOT363

**Ordering Information:****Reel packing specifications:**

Part number	Packaging form	Marking code	Reel quantity	Boxed reel quantity	Notes
AiP74LVC1T45GB236.TR	SOT23-6	CXXX	3000 PCS/reel	30000 PCS/box	Dimensions of plastic enclosure: 2.9mm×1.6mm Pin spacing: 0.95mm
AiP74LVC1T45GC363.TR	SOT363	CXXX	3000 PCS/reel	30000 PCS/box	Dimensions of plastic enclosure: 2.1mm×1.3mm Pin spacing: 0.65mm
AiP74LVCH1T45GB236.TR	SOT23-6	CYXX	3000 PCS/reel	30000 PCS/box	Dimensions of plastic enclosure: 2.9mm×1.6mm Pin spacing: 0.95mm
AiP74LVCH1T45GC363.TR	SOT363	CYXX	3000 PCS/reel	30000 PCS/box	Dimensions of plastic enclosure: 2.1mm×1.3mm Pin spacing: 0.65mm

Note 1: "XX" refers to variable content, meaning year and package batch serial number.

Note 2: If the physical information is inconsistent with the ordering information, please refer to the actual product.



2、Block Diagram And Pin Description

2.1、Block Diagram

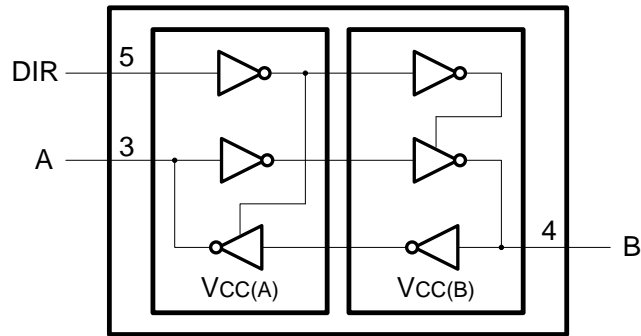

Figure 1. Logic symbol

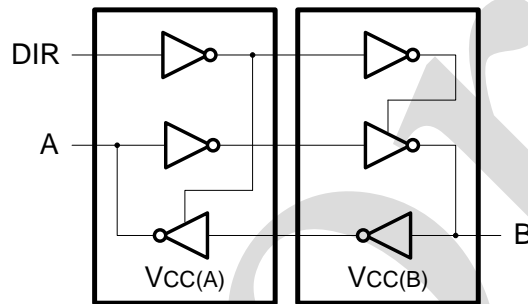
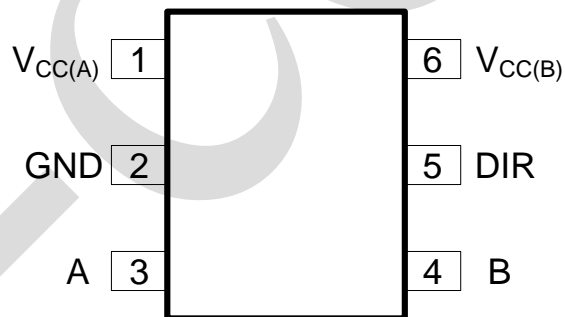

Figure 2. Logic diagram

2.2、Pin Configurations





2.3、Pin Description

Pin No.	Pin Name	Description
1	$V_{CC(A)}$	supply voltage A (port A and DIR)
2	GND	ground (0V)
3	A	data input or output
4	B	data input or output
5	DIR	direction control
6	$V_{CC(B)}$	supply voltage B (port B)

2.4、Function Table^[1]

Supply Voltage $V_{CC(A)}, V_{CC(B)}$	Input DIR	Input/output ^[2]	
		A	B
1.2V to 5.5V	L	A=B	input
1.2V to 5.5V	H	input	B=A
GND ^[3]	X	Z	Z

Note:

[1] H=HIGH voltage level; L=LOW voltage level; X=don't care; Z=high-impedance OFF-state.

[2] The input circuit of the data I/O is always active.

[3] When either $V_{CC(A)}$ or $V_{CC(B)}$ is at GND level, the device goes into suspend mode.

3、Electrical Parameter

3.1、Absolute Maximum Ratings

(Voltages are referenced to GND (ground=0V), unless otherwise specified)

Characteristic	Symbol	Conditions	Min.	Max.	Unit
supply voltage A	$V_{CC(A)}$	-	-0.5	+6.5	V
supply voltage B	$V_{CC(B)}$	-	-0.5	+6.5	V
input clamping current	I_{IK}	$V_I < 0V$	-50	-	mA
input voltage	V_I	- ^[1]	-0.5	+6.5	V
output clamping current	I_{OK}	$V_O < 0V$	-50	-	mA
output voltage	V_O	Active mode ^{[1][2][3]}	-0.5	$V_{CCO}+0.5$	V
		Suspend or 3-state mode ^[1]	-0.5	+6.5	V
output current	I_O	$V_O=0V$ to V_{CCO} ^[2]	-	± 50	mA
supply current	I_{CC}	$I_{CC(A)}$ or $I_{CC(B)}$	-	100	mA
ground current	I_{GND}	-	-100	-	mA
storage temperature	T_{stg}	-	-65	+150	°C
total power dissipation	P_{tot}	$T_{amb}=-40^{\circ}C$ to $+105^{\circ}C$	-	250	mW
soldering temperature	T_L	10s	-	250	°C

Note:

[1] The minimum input voltage ratings and output voltage ratings may be exceeded if the input and output current ratings are observed.

[2] V_{CCO} is the supply voltage associated with the output port.

[3] $V_{CCO}+0.5V$ should not exceed 6.5V.



3.2、Recommended Operating Conditions

Characteristic	Symbol	Conditions	Min.	Max.	Unit
supply voltage A	$V_{CC(A)}$	-	1.2	5.5	V
supply voltage B	$V_{CC(B)}$	-	1.2	5.5	V
input voltage	V_I	-	0	5.5	V
output voltage	V_O	Active mode ^[1]	0	V_{CCO}	V
		Suspend or 3-state mode	0	5.5	V
ambient temperature input transition rise and fall rate	T_{amb}	-	-40	+105	°C
	$\Delta t/\Delta V$	$V_{CCI}=1.2V^{[2]}$	-	20	ns/V
		$V_{CCI}=1.4V$ to $1.95V$	-	20	ns/V
		$V_{CCI}=2.3V$ to $2.7V$	-	20	ns/V
		$V_{CCI}=3V$ to $3.6V$	-	10	ns/V
		$V_{CCI}=4.5V$ to $5.5V$	-	5	ns/V

Note:

[1] V_{CCO} is the supply voltage associated with the output port.

[2] V_{CCI} is the supply voltage associated with the input port.

3.3、Electrical Characteristics

3.3.1、DC Characteristics 1

($T_{amb}=25^{\circ}C$, voltages are referenced to GND (ground=0V), unless otherwise specified)

Parameter	Symbol	Conditions	Min.	Typ.	Max.	Unit
HIGH-level output voltage	V_{OH}	$V_I=V_{IH}$ or V_{IL} ; $I_O=-3mA$; $V_{CCO}=1.2V^{[1]}$	-	1.09	-	V
LOW-level output voltage	V_{OL}	$V_I=V_{IH}$ or V_{IL} ; $I_O=3mA$; $V_{CCO}=1.2V^{[1]}$	-	0.07	-	V
input leakage current	I_I	DIR input; $V_I=0V$ to $5.5V$; $V_{CCI}=1.2V$ to $5.5V^{[2]}$	-	-	± 1	μA
bus hold LOW current	I_{BHL}	A or B port; $V_I=0.42V$; $V_{CCI}=1.2V^{[2]}$	-	19	-	μA
bus hold HIGH current	I_{BHH}	A or B port; $V_I=0.78V$; $V_{CCI}=1.2V^{[2]}$	-	-19	-	μA
bus hold LOW overdrive current	I_{BHLO}	A or B port; $V_{CCI}=1.2V^{[2][3]}$	-	19	-	μA
bus hold HIGH overdrive current	I_{BHHO}	A or B port; $V_{CCI}=1.2V^{[2][3]}$	-	-19	-	μA
OFF-state output current	I_{OZ}	A or B port; $V_O=0V$ or V_{CCO} ; $V_{CCO}=1.2V$ to $5.5V^{[1]}$	-	-	± 1	μA
power-off leakage current	I_{OFF}	A port; V_I or $V_O=0V$ to $5.5V$; $V_{CC(A)}=0V$; $V_{CC(B)}=1.2V$ to $5.5V$	-	-	± 1	μA
		B port; V_I or $V_O=0V$ to $5.5V$; $V_{CC(B)}=0V$; $V_{CC(A)}=1.2V$ to $5.5V$	-	-	± 1	μA
input capacitance	C_I	DIR input; $V_I=0V$ or $3.3V$; $V_{CC(A)}=V_{CC(B)}=3.3V$	-	2.2	-	pF
input/output capacitance	$C_{I/O}$	A and B port; suspend mode; $V_O=3.3V$ or $0V$; $V_{CC(A)}=V_{CC(B)}=3.3V$	-	6.0	-	pF



Note:

[1] V_{CCO} is the supply voltage associated with the output port.

[2] V_{CCI} is the supply voltage associated with the data input port.

[3] To guarantee the node switches, an external driver must source/sink at least I_{BHLO}/I_{BHHO} when the input is in the range V_{IL} to V_{IH} .

3.3.2、DC Characteristics 2

($T_{amb}=-40^{\circ}C$ to $+85^{\circ}C$, voltages are referenced to GND (ground=0V), unless otherwise specified)

Parameter	Symbol	Conditions	Min.	Typ.	Max.	Unit	
HIGH-level input voltage	V_{IH}	data input ^[1]	$V_{CCI}=1.2V$	$0.8V_{CCI}$	-	-	V
			$V_{CCI}=1.4V$ to $1.95V$	$0.65V_{CCI}$	-	-	V
			$V_{CCI}=2.3V$ to $2.7V$	1.7	-	-	V
			$V_{CCI}=3.0V$ to $3.6V$	2.0	-	-	V
			$V_{CCI}=4.5V$ to $5.5V$	$0.7V_{CCI}$	-	-	V
		DIR input	$V_{CCI}=1.2V$	$0.8V_{CC(A)}$	-	-	V
			$V_{CCI}=1.4V$ to $1.95V$	$0.65V_{CC(A)}$	-	-	V
			$V_{CCI}=2.3V$ to $2.7V$	1.7	-	-	V
			$V_{CCI}=3.0V$ to $3.6V$	2.0	-	-	V
			$V_{CCI}=4.5V$ to $5.5V$	$0.7V_{CC(A)}$	-	-	V
LOW-level input voltage	V_{IL}	data input ^[1]	$V_{CCI}=1.2V$	-	-	$0.2V_{CCI}$	V
			$V_{CCI}=1.4V$ to $1.95V$	-	-	$0.35V_{CCI}$	V
			$V_{CCI}=2.3V$ to $2.7V$	-	-	0.7	V
			$V_{CCI}=3.0V$ to $3.6V$	-	-	0.8	V
			$V_{CCI}=4.5V$ to $5.5V$	-	-	$0.3V_{CCI}$	V
		DIR input	$V_{CCI}=1.2V$	-	-	$0.2V_{CC(A)}$	V
			$V_{CCI}=1.4V$ to $1.95V$	-	-	$0.35V_{CC(A)}$	V
			$V_{CCI}=2.3V$ to $2.7V$	-	-	0.7	V
			$V_{CCI}=3.0V$ to $3.6V$	-	-	0.8	V
			$V_{CCI}=4.5V$ to $5.5V$	-	-	$0.3V_{CC(A)}$	V
HIGH-level output voltage	V_{OH}	$V_I=V_{IH}$	$I_O=-100\mu A$; $V_{CCO}=1.2V$ to $4.5V$ ^[2]	$V_{CCO}-0.1$	-	-	V
			$I_O=-6mA$; $V_{CCO}=1.4V$	1.0	-	-	V
			$I_O=-8mA$; $V_{CCO}=1.65V$	1.2	-	-	V
			$I_O=-12mA$; $V_{CCO}=2.3V$	1.9	-	-	V
			$I_O=-24mA$; $V_{CCO}=3.0V$	2.4	-	-	V
			$I_O=-32mA$; $V_{CCO}=4.5V$	3.8	-	-	V
LOW-level output voltage	V_{OL}	$V_I=V_{IH}$ ^[2]	$I_O=100\mu A$; $V_{CCO}=1.2V$ to $4.5V$	-	-	0.1	V
			$I_O=6mA$; $V_{CCO}=1.4V$	-	-	0.3	V
			$I_O=8mA$; $V_{CCO}=1.65V$	-	-	0.45	V
			$I_O=12mA$; $V_{CCO}=2.3V$	-	-	0.3	V
			$I_O=24mA$; $V_{CCO}=3.0V$	-	-	0.55	V
$I_O=32mA$; $V_{CCO}=4.5V$	-	-	0.55	V			
input leakage current	I_I	DIR input; $V_I=0V$ to $5.5V$; $V_{CCI}=1.2V$ to $5.5V$	-	-	± 2	μA	



Wuxi I-CORE Electronics Co., Ltd.

Tab: 835-12

rev:B3

Number: AiP74LVC/LVCH1T45-AX-LJ-B087EN

bus hold LOW current	I_{BHL}	A or B port ^[1]	$V_I=0.49V; V_{CCI}=1.4V$	15	-	-	uA
			$V_I=0.58V; V_{CCI}=1.65V$	25	-	-	uA
			$V_I=0.70V; V_{CCI}=2.3V$	45	-	-	uA
			$V_I=0.80V; V_{CCI}=3.0V$	100	-	-	uA
			$V_I=1.35V; V_{CCI}=4.5V$	100	-	-	uA
bus hold HIGH current	I_{BHH}	A or B port ^[1]	$V_I=0.91V; V_{CCI}=1.4V$	-15	-	-	uA
			$V_I=1.07V; V_{CCI}=1.65V$	-25	-	-	uA
			$V_I=1.60V; V_{CCI}=2.3V$	-45	-	-	uA
			$V_I=2.00V; V_{CCI}=3.0V$	-100	-	-	uA
			$V_I=3.15V; V_{CCI}=4.5V$	-100	-	-	uA
bus hold LOW overdrive current	I_{BHLO}	A or B port ^{[1][3]}	$V_{CCI}=1.6V$	125	-	-	uA
			$V_{CCI}=1.95V$	200	-	-	uA
			$V_{CCI}=2.7V$	300	-	-	uA
			$V_{CCI}=3.6V$	500	-	-	uA
			$V_{CCI}=5.5V$	900	-	-	uA
bus hold HIGH overdrive current	I_{BHHO}	A or B port ^{[1][3]}	$V_{CCI}=1.6V$	-125	-	-	uA
			$V_{CCI}=1.95V$	-200	-	-	uA
			$V_{CCI}=2.7V$	-300	-	-	uA
			$V_{CCI}=3.6V$	-500	-	-	uA
			$V_{CCI}=5.5V$	-900	-	-	uA
OFF-state output	I_{OZ}	A or B port; $V_O=0V$ or V_{CCO} ; $V_{CCO}=1.2V$ to $5.5V$ ^[2]		-	-	± 2	uA
power-off leakage current	I_{OFF}	A port; V_I or $V_O=0V$ to $5.5V$; $V_{CC(A)}=0V$; $V_{CC(B)}=1.2V$ to $5.5V$		-	-	± 2	uA
		B port; V_I or $V_O=0V$ to $5.5V$; $V_{CC(B)}=0V$; $V_{CC(A)}=1.2V$ to $5.5V$		-	-	± 2	uA
supply current	I_{CC}	A port; $V_I=0V$ or V_{CCI} ; $I_O=0A$ ^[1]	$V_{CC(A)}, V_{CC(B)}=1.2V$ to $5.5V$	-	-	8	uA
			$V_{CC(A)}, V_{CC(B)}=1.65V$ to $5.5V$	-	-	3	uA
			$V_{CC(A)}=5.5V$; $V_{CC(B)}=0V$	-	-	2	uA
			$V_{CC(A)}=0V$; $V_{CC(B)}=5.5V$	-2	-	-	uA
		B port; $V_I=0V$ or V_{CCI} ; $I_O=0A$	$V_{CC(A)}, V_{CC(B)}=1.2V$ to $5.5V$	-	-	8	uA
			$V_{CC(A)}, V_{CC(B)}=1.65V$ to $5.5V$	-	-	3	uA
			$V_{CC(B)}=0V$; $V_{CC(A)}=5.5V$	-2	-	-	uA
			$V_{CC(B)}=5.5V$; $V_{CC(A)}=0V$	-	-	2	uA
		A plus B port ($I_{CC(A)}+I_{CC(B)}$); $I_O=0A$; $V_I=0V$ or V_{CCI}	$V_{CC(A)}, V_{CC(B)}=1.2V$ to $5.5V$	-	-	16	uA
			$V_{CC(A)}, V_{CC(B)}=1.65V$ to $5.5V$	-	-	4	uA
additional supply current	ΔI_{CC}	per input; $V_{CC(A)}, V_{CC(B)}=$ $3.0V$ to $5.5V$	A port; A port at $V_{CC(A)}-0.6V$; DIR at $V_{CC(A)}$; B port=open ^[4]	-	-	50	uA
			DIR input; DIR at $V_{CC(A)}-0.6V$; A port at $V_{CC(A)}$ or GND; B port=open	-	-	50	uA
			B port; B port at $V_{CC(B)}-0.6V$; DIR at GND; A port=open ^[4]	-	-	50	uA



Note:

[1] V_{CCI} is the supply voltage associated with the data input port.

[2] V_{CCO} is the supply voltage associated with the output port.

[3] To guarantee the node switches, an external driver must source/sink at least I_{BHLO}/I_{BHHO} when the input is in the range V_{IL} to V_{IH} .

[4] For non bus hold parts only (AiP74LVC1T45).

3.3.3、DC Characteristics 3

($T_{amb}=-40^{\circ}\text{C}$ to $+105^{\circ}\text{C}$, voltages are referenced to GND (ground=0V), unless otherwise specified)

Parameter	Symbol	Conditions	Min.	Typ.	Max.	Unit	
HIGH-level input voltage	V_{IH}	data input ^[1]	$V_{CCI}=1.2\text{V}$	$0.8V_{CCI}$	-	-	V
			$V_{CCI}=1.4\text{V}$ to 1.95V	$0.65V_{CCI}$	-	-	V
			$V_{CCI}=2.3\text{V}$ to 2.7V	1.7	-	-	V
			$V_{CCI}=3.0\text{V}$ to 3.6V	2.0	-	-	V
			$V_{CCI}=4.5\text{V}$ to 5.5V	$0.7V_{CCI}$	-	-	V
		DIR input	$V_{CCI}=1.2\text{V}$	$0.8V_{CC(A)}$	-	-	V
			$V_{CCI}=1.4\text{V}$ to 1.95V	$0.65V_{CC(A)}$	-	-	V
			$V_{CCI}=2.3\text{V}$ to 2.7V	1.7	-	-	V
			$V_{CCI}=3.0\text{V}$ to 3.6V	2.0	-	-	V
			$V_{CCI}=4.5\text{V}$ to 5.5V	$0.7V_{CC(A)}$	-	-	V
LOW-level input voltage	V_{IL}	data input ^[1]	$V_{CCI}=1.2\text{V}$	-	-	$0.2V_{CCI}$	V
			$V_{CCI}=1.4\text{V}$ to 1.95V	-	-	$0.35V_{CCI}$	V
			$V_{CCI}=2.3\text{V}$ to 2.7V	-	-	0.7	V
			$V_{CCI}=3.0\text{V}$ to 3.6V	-	-	0.8	V
			$V_{CCI}=4.5\text{V}$ to 5.5V	-	-	$0.3V_{CCI}$	V
		DIR input	$V_{CCI}=1.2\text{V}$	-	-	$0.2V_{CC(A)}$	V
			$V_{CCI}=1.4\text{V}$ to 1.95V	-	-	$0.35V_{CC(A)}$	V
			$V_{CCI}=2.3\text{V}$ to 2.7V	-	-	0.7	V
			$V_{CCI}=3.0\text{V}$ to 3.6V	-	-	0.8	V
			$V_{CCI}=4.5\text{V}$ to 5.5V	-	-	$0.3V_{CC(A)}$	V
HIGH-level output voltage	V_{OH}	$V_I=V_{IH}$	$I_O=-100\mu\text{A}; V_{CCO}=1.2\text{V}$ to $4.5\text{V}^{[2]}$	$V_{CCO}-0.1$	-	-	V
			$I_O=-6\text{mA}; V_{CCO}=1.4\text{V}$	1.0	-	-	V
			$I_O=-8\text{mA}; V_{CCO}=1.65\text{V}$	1.2	-	-	V
			$I_O=-12\text{mA}; V_{CCO}=2.3\text{V}$	1.9	-	-	V
			$I_O=-24\text{mA}; V_{CCO}=3.0\text{V}$	2.4	-	-	V
			$I_O=-32\text{mA}; V_{CCO}=4.5\text{V}$	3.8	-	-	V
LOW-level output voltage	V_{OL}	$V_I=V_{IH}^{[2]}$	$I_O=100\mu\text{A}; V_{CCO}=1.2\text{V}$ to 4.5V	-	-	0.1	V
			$I_O=6\text{mA}; V_{CCO}=1.4\text{V}$	-	-	0.3	V
			$I_O=8\text{mA}; V_{CCO}=1.65\text{V}$	-	-	0.45	V
			$I_O=12\text{mA}; V_{CCO}=2.3\text{V}$	-	-	0.3	V
			$I_O=24\text{mA}; V_{CCO}=3.0\text{V}$	-	-	0.55	V
			$I_O=32\text{mA}; V_{CCO}=4.5\text{V}$	-	-	0.55	V



input leakage current	I_I	DIR input; $V_I=0V$ to 5.5V; $V_{CCI}=1.2V$ to 5.5V		-	-	± 2	μA
bus hold LOW current	I_{BHL}	A or B port ^[1]	$V_I=0.49V$; $V_{CCI}=1.4V$	15	-	-	μA
			$V_I=0.58V$; $V_{CCI}=1.65V$	20	-	-	μA
			$V_I=0.70V$; $V_{CCI}=2.3V$	45	-	-	μA
			$V_I=0.80V$; $V_{CCI}=3.0V$	80	-	-	μA
			$V_I=1.35V$; $V_{CCI}=4.5V$	100	-	-	μA
bus hold HIGH current	I_{BHH}	A or B port ^[1]	$V_I=0.91V$; $V_{CCI}=1.4V$	-10	-	-	μA
			$V_I=1.07V$; $V_{CCI}=1.65V$	-20	-	-	μA
			$V_I=1.60V$; $V_{CCI}=2.3V$	-45	-	-	μA
			$V_I=2.00V$; $V_{CCI}=3.0V$	-80	-	-	μA
			$V_I=3.15V$; $V_{CCI}=4.5V$	-100	-	-	μA
bus hold LOW overdrive current	I_{BHLO}	A or B port ^{[1][3]}	$V_{CCI}=1.6V$	125	-	-	μA
			$V_{CCI}=1.95V$	200	-	-	μA
			$V_{CCI}=2.7V$	300	-	-	μA
			$V_{CCI}=3.6V$	500	-	-	μA
			$V_{CCI}=5.5V$	900	-	-	μA
bus hold HIGH overdrive current	I_{BHHO}	A or B port ^{[1][3]}	$V_{CCI}=1.6V$	-125	-	-	μA
			$V_{CCI}=1.95V$	-200	-	-	μA
			$V_{CCI}=2.7V$	-300	-	-	μA
			$V_{CCI}=3.6V$	-500	-	-	μA
			$V_{CCI}=5.5V$	-900	-	-	μA
OFF-state output	I_{OZ}	A or B port; $V_O=0V$ or V_{CCO} ; $V_{CCO}=1.2V$ to 5.5V ^[2]		-	-	± 10	μA
power-off leakage current	I_{OFF}	A port; V_I or $V_O=0V$ to 5.5V; $V_{CC(A)}=0V$; $V_{CC(B)}=1.2V$ to 5.5V		-	-	± 10	μA
		B port; V_I or $V_O=0V$ to 5.5V; $V_{CC(B)}=0V$; $V_{CC(A)}=1.2V$ to 5.5V		-	-	± 10	μA
supply current	I_{CC}	A port; $V_I=0V$ or V_{CCI} ; $I_O=0A$ ^[1]	$V_{CC(A)}, V_{CC(B)}=1.2V$ to 5.5V	-	-	8	μA
			$V_{CC(A)}, V_{CC(B)}=1.65V$ to 5.5V	-	-	3	μA
			$V_{CC(A)}=5.5V$; $V_{CC(B)}=0V$	-	-	2	μA
			$V_{CC(A)}=0V$; $V_{CC(B)}=5.5V$	-2	-	-	μA
		B port; $V_I=0V$ or V_{CCI} ; $I_O=0A$	$V_{CC(A)}, V_{CC(B)}=1.2V$ to 5.5V	-	-	8	μA
			$V_{CC(A)}, V_{CC(B)}=1.65V$ to 5.5V	-	-	3	μA
			$V_{CC(B)}=0V$; $V_{CC(A)}=5.5V$	-2	-	-	μA
			$V_{CC(B)}=5.5V$; $V_{CC(A)}=0V$	-	-	2	μA
		A plus B port ($I_{CC(A)}+I_{CC(B)}$); $I_O=0A$; $V_I=0V$ or V_{CCI}	$V_{CC(A)}, V_{CC(B)}=1.2V$ to 5.5V	-	-	16	μA
			$V_{CC(A)}, V_{CC(B)}=1.65V$ to 5.5V	-	-	4	μA
additional supply current	ΔI_{CC}	per input; $V_{CC(A)}, V_{CC(B)}=3.0V$ to 5.5V	A port; A port at $V_{CC(A)}-0.6V$; DIR at $V_{CC(A)}$; B port=open ^[4]	-	-	75	μA
			DIR input; DIR at $V_{CC(A)}-0.6V$; A port at $V_{CC(A)}$ or GND; B port=open	-	-	75	μA



			B port; B port at $V_{CC(B)}-0.6V$; DIR at GND; A port=open ^[4]	-	-	75	uA
--	--	--	--	---	---	----	----

Note:

[1] V_{CCI} is the supply voltage associated with the data input port.

[2] V_{CCO} is the supply voltage associated with the output port.

[3] To guarantee the node switches, an external driver must source/sink at least I_{BHLO}/I_{BHHO} when the input is in the range V_{IL} to V_{IH} .

[4] For non bus hold parts only (AiP74LVC1T45).

3.3.4、AC Characteristics 1

($T_{amb}=25^{\circ}C$, $V_{CC(A)}=1.2V$, voltages are referenced to GND (ground=0V), unless otherwise specified)

Parameter	Symbol	Conditions	$V_{CC(B)}$						Unit
			1.2V	1.5V	1.8V	2.5V	3.3V	5.0V	
LOW to HIGH propagation delay	t_{PLH}	A to B	10.6	8.1	7.0	5.8	5.3	5.1	ns
		B to A	10.6	9.5	9.0	8.5	8.3	8.2	ns
HIGH to LOW propagation delay	t_{PHL}	A to B	10.1	7.1	6.0	5.3	5.2	5.4	ns
		B to A	10.1	8.6	8.1	7.8	7.6	7.6	ns
HIGH to OFF-state propagation delay	t_{PHZ}	DIR to A	9.4	9.4	9.4	9.4	9.4	9.4	ns
		DIR to B	12.0	9.4	9.0	7.8	8.4	7.9	ns
LOW to OFF-state propagation delay	t_{PLZ}	DIR to A	7.1	7.1	7.1	7.1	7.1	7.1	ns
		DIR to B	9.5	7.8	7.7	6.9	7.6	7.0	ns
OFF-state to HIGH propagation delay	t_{PZH}	DIR to A ^[1]	20.1	17.3	16.7	15.4	15.9	15.2	ns
		DIR to B ^[1]	17.7	15.2	14.1	12.9	12.4	12.2	ns
OFF-state to LOW propagation delay	t_{PZL}	DIR to A ^[1]	22.1	18.0	17.1	15.6	16.0	15.5	ns
		DIR to B ^[1]	19.5	16.5	15.4	14.7	14.6	14.8	ns

Note:

[1] t_{PZH} and t_{PZL} are calculated values using the formula shown in Section 6.4.

3.3.5、AC Characteristics 2

($T_{amb}=25^{\circ}C$, $V_{CC(B)}=1.2V$, voltages are referenced to GND (ground=0V), unless otherwise specified)

Parameter	Symbol	Conditions	$V_{CC(A)}$						Unit
			1.2V	1.5V	1.8V	2.5V	3.3V	5.0V	
LOW to HIGH propagation delay	t_{PLH}	A to B	10.6	9.5	9.0	8.5	8.3	8.2	ns
		B to A	10.6	8.1	7.0	5.8	5.3	5.1	ns
HIGH to LOW propagation delay	t_{PHL}	A to B	10.1	8.6	8.1	7.8	7.6	7.6	ns
		B to A	10.1	7.1	6.0	5.3	5.2	5.4	ns
HIGH to OFF-state propagation delay	t_{PHZ}	DIR to A	9.4	6.5	5.7	4.1	4.1	3.0	ns
		DIR to B	12.0	6.1	5.4	4.6	4.3	4.0	ns
LOW to OFF-state propagation delay	t_{PLZ}	DIR to A	7.1	4.9	4.5	3.2	3.4	2.5	ns
		DIR to B	9.5	7.3	6.6	5.9	5.7	5.6	ns
OFF-state to HIGH propagation delay	t_{PZH}	DIR to A ^[1]	20.1	15.4	13.6	11.7	11.0	10.7	ns
		DIR to B ^[1]	17.7	14.4	13.5	11.7	11.7	10.7	ns
OFF-state to LOW propagation delay	t_{PZL}	DIR to A ^[1]	22.1	13.2	11.4	9.9	9.5	9.4	ns
		DIR to B ^[1]	19.5	15.1	13.8	11.9	11.7	10.6	ns

Note:



[1] t_{PZH} and t_{PZL} are calculated values using the formula shown in Section 6.4.

3.3.6、AC Characteristics 3

($T_{amb}=25^{\circ}\text{C}$, $V_{CC(A)}=V_{CC(B)}$, voltages are referenced to GND (ground=0V), unless otherwise specified)

Parameter	Symbol	Conditions	$V_{CC(A)}$ and $V_{CC(B)}$				Unit
			1.8V	2.5V	3.3V	5.0V	
power dissipation capacitance ^{[1][2]}	C_{PD}	A port: (direction A to B); B port: (direction B to A)	2	3	3	4	pF
		A port: (direction A to B); B port: (direction B to A)	15	16	16	18	pF

Note:

[1] C_{PD} is used to determine the dynamic power dissipation (P_D in uW).

$$P_D = C_{PD} \times V_{CC}^2 \times f_i \times N + \Sigma(C_L \times V_{CC}^2 \times f_o) \text{ where:}$$

f_i =input frequency in MHz;

f_o =output frequency in MHz;

C_L =load capacitance in pF;

V_{CC} =supply voltage in V;

N =number of inputs switching;

$\Sigma(C_L \times V_{CC}^2 \times f_o)$ =sum of the outputs.

[2] $f_i=10\text{MHz}$; $V_I=\text{GND to } V_{CC}$; $t_r=t_f=1\text{ns}$; $C_L=0\text{pF}$; $R_L=\infty\Omega$.

3.3.7、AC Characteristics 4

($T_{amb}=-40^{\circ}\text{C}$ to $+85^{\circ}\text{C}$, voltages are referenced to GND (ground=0V), unless otherwise specified)

Parameter	Symbol	Conditions	$V_{CC(B)}$										Unit
			1.5V±0.1V		1.8V±0.15V		2.5V±0.2V		3.3V±0.3V		5.0V±0.5V		
			Min.	Max.	Min.	Max.	Min.	Max.	Min.	Max.	Min.	Max.	
$V_{CC(A)}=1.4\text{V to }1.6\text{V}$													
LOW to HIGH propagation delay	t_{PLH}	A to B	2.8	21.3	2.4	17.6	2.0	13.5	1.7	11.8	1.6	10.5	ns
		B to A	2.8	21.3	2.6	19.1	2.3	14.9	2.3	12.4	2.2	12.0	ns
HIGH to LOW propagation delay	t_{PHL}	A to B	2.6	19.3	2.2	15.3	1.8	11.8	1.7	10.9	1.7	10.8	ns
		B to A	2.6	19.3	2.4	17.3	2.3	13.2	2.2	11.3	2.3	11.0	ns
HIGH to OFF-state propagation delay	t_{PHZ}	DIR to A	3.0	18.7	3.0	18.7	3.0	18.7	3.0	18.7	3.0	18.7	ns
		DIR to B	3.5	24.8	3.5	23.6	3.0	11.0	3.3	11.3	2.8	10.3	ns
LOW to OFF-state propagation delay	t_{PLZ}	DIR to A	2.4	11.4	2.4	11.4	2.4	11.4	2.4	11.4	2.4	11.4	ns
		DIR to B	2.8	18.3	3.0	17.2	2.5	9.4	3.0	10.1	2.5	9.4	ns
OFF-state to HIGH propagation delay	t_{PZH}	DIR to A ^[1]	-	39.6	-	36.3	-	24.3	-	22.5	-	21.4	ns
		DIR to B ^[1]	-	32.7	-	29.0	-	24.9	-	23.2	-	21.9	ns



Wuxi I-CORE Electronics Co., Ltd.

Tab: 835-12

rev:B3

Number: AiP74LVC/LVCH1T45-AX-LJ-B087EN

OFF-state to LOW propagation delay	t_{PZL}	DIR to A ^[1]	-	44.1	-	40.9	-	24.2	-	22.6	-	21.3	ns
		DIR to B ^[1]	-	38.0	-	34.0	-	30.5	-	29.6	-	29.5	ns
$V_{CC(A)}=1.65V$ to $1.95V$													
LOW to HIGH propagation delay	t_{PLH}	A to B	2.6	19.1	2.2	17.7	2.2	9.3	1.7	7.2	1.4	6.8	ns
		B to A	2.4	17.6	2.2	17.7	2.3	16.0	2.1	15.5	1.9	15.1	ns
HIGH to LOW propagation delay	t_{PHL}	A to B	2.4	17.3	2.0	14.3	1.6	8.5	1.8	7.1	1.7	7.0	ns
		B to A	2.2	15.3	2.0	14.3	2.1	12.9	2.0	12.6	1.8	12.2	ns
HIGH to OFF-state propagation delay	t_{PHZ}	DIR to A	2.9	17.1	2.9	17.1	2.9	17.1	2.9	17.1	2.9	17.1	ns
		DIR to B	3.2	24.1	3.2	21.9	2.7	11.5	3.0	10.3	2.5	8.2	ns
LOW to OFF-state propagation delay	t_{PLZ}	DIR to A	2.4	10.5	2.4	10.5	2.4	10.5	2.4	10.5	2.4	10.5	ns
		DIR to B	2.5	17.6	2.6	16.0	2.2	9.2	2.7	8.4	2.4	6.4	ns
OFF-state to HIGH propagation delay	t_{PZH}	DIR to A ^[1]	-	35.2	-	33.7	-	25.2	-	23.9	-	21.8	ns
		DIR to B ^[1]	-	29.6	-	28.2	-	19.8	-	17.7	-	17.3	ns
OFF-state to LOW propagation delay	t_{PZL}	DIR to A ^[1]	-	39.4	-	36.2	-	24.4	-	22.9	-	20.4	ns
		DIR to B ^[1]	-	34.4	-	31.4	-	25.6	-	24.2	-	24.1	ns
$V_{CC(A)}=2.3V$ to $2.7V$													
LOW to HIGH propagation delay	t_{PLH}	A to B	2.3	17.9	2.3	16.0	1.5	8.5	1.3	6.2	1.1	4.8	ns
		B to A	2.0	13.5	2.2	9.3	1.5	8.5	1.4	8.0	1.0	7.5	ns
HIGH to LOW propagation delay	t_{PHL}	A to B	2.3	15.8	2.1	12.9	1.4	7.5	1.3	5.4	0.9	4.6	ns
		B to A	1.8	11.8	1.9	8.5	1.4	7.5	1.3	7.0	0.9	6.2	ns
HIGH to OFF-state propagation delay	t_{PHZ}	DIR to A	2.1	8.1	2.1	8.1	2.1	8.1	2.1	8.1	2.1	8.1	ns
		DIR to B	3.0	22.5	3.0	21.4	2.5	11.0	2.8	9.3	2.3	6.9	ns
LOW to OFF-state propagation delay	t_{PLZ}	DIR to A	1.7	5.8	1.7	5.8	1.7	5.8	1.7	5.8	1.7	5.8	ns
		DIR to B	2.3	14.6	2.5	13.2	2.0	9.0	2.5	8.4	1.8	5.3	ns
OFF-state to HIGH propagation delay	t_{PZH}	DIR to A ^[1]	-	28.1	-	22.5	-	17.5	-	16.4	-	12.8	ns
		DIR to B ^[1]	-	23.7	-	21.8	-	14.3	-	12.0	-	10.6	ns
OFF-state to LOW propagation delay	t_{PZL}	DIR to A ^[1]	-	34.3	-	29.9	-	18.5	-	16.3	-	13.1	ns
		DIR to B ^[1]	-	23.9	-	21.0	-	15.6	-	13.5	-	12.7	ns



Wuxi I-CORE Electronics Co., Ltd.

Tab: 835-12

rev:B3

Number: AiP74LVC/LVCH1T45-AX-LJ-B087EN

V _{CC(A)} =3.0V to 3.6V													
LOW to HIGH propagation delay	t _{PLH}	A to B	2.3	17.1	2.1	15.5	1.4	8.0	0.8	5.6	0.7	4.4	ns
		B to A	1.7	11.8	1.7	7.2	1.3	6.2	0.7	5.6	0.6	5.4	ns
HIGH to LOW propagation delay	t _{PHL}	A to B	2.2	15.6	2.0	12.6	1.3	7.0	0.8	5.0	0.7	4.0	ns
		B to A	1.7	10.9	1.8	7.1	1.3	5.4	0.8	5.0	0.7	4.5	ns
HIGH to OFF-state propagation delay	t _{PHZ}	DIR to A	2.3	7.3	2.3	7.3	2.3	7.3	2.3	7.3	2.7	7.3	ns
		DIR to B	2.9	18.0	2.9	16.5	2.3	10.1	2.7	8.6	2.2	6.3	ns
LOW to OFF-state propagation delay	t _{PLZ}	DIR to A	2.0	5.6	2.0	5.6	2.0	5.6	2.0	5.6	2.0	5.6	ns
		DIR to B	2.3	13.6	2.4	12.5	1.9	7.8	2.3	7.1	1.7	4.9	ns
OFF-state to HIGH propagation delay	t _{PZH}	DIR to A ^[1]	-	25.4	-	19.7	-	14.0	-	12.7	-	10.3	ns
		DIR to B ^[1]	-	22.7	-	21.1	-	13.6	-	11.2	-	10.0	ns
OFF-state to LOW propagation delay	t _{PZL}	DIR to A ^[1]	-	28.9	-	23.6	-	15.5	-	13.6	-	10.8	ns
		DIR to B ^[1]	-	22.9	-	19.9	-	14.3	-	12.3	-	11.3	ns
V _{CC(A)} =4.5V to 5.5V													
LOW to HIGH propagation delay	t _{PLH}	A to B	2.2	16.6	1.9	15.1	1.0	7.5	0.7	5.4	0.5	3.9	ns
		B to A	1.6	10.5	1.4	6.8	1.0	4.8	0.7	4.4	0.5	3.9	ns
HIGH to LOW propagation delay	t _{PHL}	A to B	2.3	15.3	1.8	12.2	1.0	6.2	0.7	4.5	0.5	3.5	ns
		B to A	1.7	10.8	1.7	7.0	0.9	4.6	0.7	4.0	0.5	3.5	ns
HIGH to OFF-state propagation delay	t _{PHZ}	DIR to A	1.7	5.4	1.7	5.4	1.7	5.4	1.7	5.4	1.7	5.4	ns
		DIR to B	2.9	17.3	2.9	16.1	2.3	9.7	2.7	8.0	2.5	5.7	ns
LOW to OFF-state propagation delay	t _{PLZ}	DIR to A	1.4	3.7	1.4	3.7	1.3	3.7	1.0	3.7	0.9	3.7	ns
		DIR to B	2.3	13.1	2.4	12.1	1.9	7.4	2.3	7.0	1.8	4.5	ns
OFF-state to HIGH propagation delay	t _{PZH}	DIR to A ^[1]	-	23.6	-	18.9	-	12.2	-	11.4	-	8.4	ns
		DIR to B ^[1]	-	20.3	-	18.8	-	11.2	-	9.1	-	7.6	ns
OFF-state to LOW propagation delay	t _{PZL}	DIR to A ^[1]	-	28.1	-	23.1	-	14.3	-	12.0	-	9.2	ns
		DIR to B ^[1]	-	20.7	-	17.6	-	11.6	-	9.9	-	8.9	ns

Note: [1] t_{PZH} and t_{PZL} are calculated values using the formula shown in Section 6.4.



3.3.8、AC Characteristics 5

($T_{amb}=-40^{\circ}\text{C}$ to $+105^{\circ}\text{C}$, voltages are referenced to GND (ground=0V), unless otherwise specified)

Parameter	Symbol	Conditions	$V_{CC(B)}$										Unit
			1.5V±0.1V		1.8V±0.15V		2.5V±0.2V		3.3V±0.3V		5.0V±0.5V		
			Min.	Max.	Min.	Max.	Min.	Max.	Min.	Max.	Min.	Max.	
$V_{CC(A)}=1.4\text{V to }1.6\text{V}$													
LOW to HIGH propagation delay	t_{PLH}	A to B	2.5	23.5	2.1	19.4	1.8	14.9	1.5	13.0	1.4	11.6	ns
		B to A	2.5	23.5	2.3	21.1	2.0	16.4	2.0	13.7	1.9	13.2	ns
HIGH to LOW propagation delay	t_{PHL}	A to B	2.3	21.3	1.9	16.9	1.6	13.0	1.5	12.0	1.5	11.9	ns
		B to A	2.3	21.3	2.1	19.1	2.0	14.6	1.9	12.5	2.0	12.1	ns
HIGH to OFF-state propagation delay	t_{PHZ}	DIR to A	2.7	20.6	2.7	20.6	2.7	20.6	2.7	20.6	2.7	20.6	ns
		DIR to B	3.1	27.3	3.1	26.0	2.7	12.1	2.9	12.5	2.5	11.4	ns
LOW to OFF-state propagation delay	t_{PLZ}	DIR to A	2.1	12.6	2.1	12.6	2.1	12.6	2.1	12.6	2.1	12.6	ns
		DIR to B	2.5	20.2	2.7	19.0	2.2	10.4	2.7	11.2	2.2	10.4	ns
OFF-state to HIGH propagation delay	t_{PZH}	DIR to A ^[1]	-	43.7	-	40.1	-	26.8	-	24.9	-	23.6	ns
		DIR to B ^[1]	-	36.1	-	32.0	-	27.5	-	25.6	-	24.2	ns
OFF-state to LOW propagation delay	t_{PZL}	DIR to A ^[1]	-	48.6	-	45.1	-	26.7	-	25.0	-	23.5	ns
		DIR to B ^[1]	-	41.9	-	37.5	-	33.6	-	32.6	-	32.5	ns
$V_{CC(A)}=1.65\text{V to }1.95\text{V}$													
LOW to HIGH propagation delay	t_{PLH}	A to B	2.3	21.1	1.9	19.5	1.9	10.3	1.5	8.0	1.2	7.5	ns
		B to A	2.1	19.4	1.9	19.5	2.0	17.6	1.8	17.1	1.7	16.7	ns
HIGH to LOW propagation delay	t_{PHL}	A to B	2.1	19.1	1.8	15.8	1.4	9.4	1.6	7.9	1.5	7.7	ns
		B to A	1.9	16.9	1.8	15.8	1.8	14.2	1.8	13.9	1.6	13.5	ns
HIGH to OFF-state propagation delay	t_{PHZ}	DIR to A	2.6	18.9	2.6	18.9	2.6	18.9	2.6	18.9	2.6	18.9	ns
		DIR to B	2.8	26.6	2.8	24.1	2.4	12.7	2.7	11.4	2.2	9.1	ns
LOW to OFF-state propagation delay	t_{PLZ}	DIR to A	2.1	11.6	2.1	11.6	2.1	11.6	2.1	11.6	2.1	11.6	ns
		DIR to B	2.2	19.4	2.3	17.6	1.9	10.2	2.4	9.3	2.1	7.4	ns
OFF-state to HIGH propagation delay	t_{PZH}	DIR to A ^[1]	-	38.8	-	37.1	-	27.8	-	26.4	-	24.1	ns
		DIR to B ^[1]	-	32.7	-	31.1	-	21.9	-	19.6	-	19.1	ns
OFF-state to	t_{PZL}	DIR to A ^[1]	-	43.5	-	39.9	-	26.9	-	25.3	-	22.6	ns



Wuxi I-CORE Electronics Co., Ltd.

Tab: 835-12

rev:B3

Number: AiP74LVC/LVCH1T45-AX-LJ-B087EN

LOW propagation delay		DIR to B ^[1]	-	38.0	-	34.7	-	28.3	-	26.8	-	26.6	ns
V_{CC(A)}=2.3V to 2.7V													
LOW to HIGH propagation delay	t _{PLH}	A to B	2.0	19.7	2.0	17.6	1.3	9.4	1.1	6.9	0.9	5.3	ns
		B to A	1.8	14.9	1.9	10.3	1.3	9.4	1.2	8.8	0.9	8.3	ns
HIGH to LOW propagation delay	t _{PHL}	A to B	2.0	17.4	1.8	14.2	1.2	8.3	1.1	6.0	0.8	5.1	ns
		B to A	1.6	13.0	1.7	9.4	1.2	8.3	1.1	7.7	0.8	6.9	ns
HIGH to OFF-state propagation delay	t _{PHZ}	DIR to A	1.8	9.0	1.8	9.0	1.8	9.0	1.8	9.0	1.8	9.0	ns
		DIR to B	2.7	24.8	2.7	23.6	2.2	12.1	2.5	10.3	2.0	7.6	ns
LOW to OFF-state propagation delay	t _{PLZ}	DIR to A	1.5	6.4	1.5	6.4	1.5	6.4	1.5	6.4	1.5	6.4	ns
		DIR to B	2.0	16.1	2.5	14.6	1.8	9.9	2.2	9.3	1.6	5.9	ns
OFF-state to HIGH propagation delay	t _{PZH}	DIR to A ^[1]	-	31.0	-	24.9	-	19.3	-	18.1	-	14.2	ns
		DIR to B ^[1]	-	26.1	-	24.0	-	15.8	-	13.3	-	11.7	ns
OFF-state to LOW propagation delay	t _{PZL}	DIR to A ^[1]	-	37.8	-	33.0	-	20.4	-	18.0	-	14.5	ns
		DIR to B ^[1]	-	26.4	-	23.2	-	17.3	-	15.0	-	14.1	ns
V_{CC(A)}=3.0V to 3.6V													
LOW to HIGH propagation delay	t _{PLH}	A to B	2.0	18.9	1.8	17.1	1.2	8.8	0.7	6.2	0.6	4.9	ns
		B to A	1.5	13.0	1.5	8.0	1.1	6.9	0.6	6.2	0.5	6.0	ns
HIGH to LOW propagation delay	t _{PHL}	A to B	1.9	17.2	1.8	13.9	1.1	7.7	0.7	5.5	0.6	4.4	ns
		B to A	1.5	12.0	1.6	7.9	1.1	6.0	0.7	5.5	0.6	5.0	ns
HIGH to OFF-state propagation delay	t _{PHZ}	DIR to A	2.0	8.1	2.0	8.1	2.0	8.1	2.0	8.1	2.4	8.1	ns
		DIR to B	2.6	19.8	2.6	18.2	2.0	11.2	2.4	9.5	1.9	7.0	ns
LOW to OFF-state propagation delay	t _{PLZ}	DIR to A	1.8	6.2	1.8	6.2	1.8	6.2	1.8	6.2	1.8	6.2	ns
		DIR to B	2.0	15.0	2.1	13.8	1.7	8.6	2.0	7.9	1.5	5.4	ns
OFF-state to HIGH propagation delay	t _{PZH}	DIR to A ^[1]	-	28.0	-	21.8	-	15.5	-	14.1	-	11.4	ns
		DIR to B ^[1]	-	25.1	-	23.3	-	15.0	-	12.4	-	11.1	ns
OFF-state to LOW propagation delay	t _{PZL}	DIR to A ^[1]	-	31.8	-	26.1	-	17.2	-	15.0	-	12.0	ns
		DIR to B ^[1]	-	25.3	-	22.0	-	15.8	-	13.6	-	12.5	ns
V_{CC(A)}=4.5V to 5.5V													



LOW to HIGH propagation delay	t_{PLH}	A to B	1.9	18.3	1.7	16.7	0.9	8.3	0.6	6.0	0.4	4.3	ns
		B to A	1.4	11.6	1.2	7.5	0.9	5.3	0.6	4.9	0.4	4.3	ns
HIGH to LOW propagation delay	t_{PHL}	A to B	2.0	16.9	1.6	13.5	0.9	6.9	0.6	5.0	0.4	3.9	ns
		B to A	1.5	11.9	1.5	7.7	0.8	5.1	0.6	4.4	0.4	3.9	ns
HIGH to OFF-state propagation delay	t_{PHZ}	DIR to A	1.5	6.0	1.5	6.0	1.5	6.0	1.5	6.0	1.5	6.0	ns
		DIR to B	2.6	19.1	2.6	17.8	2.0	10.7	2.4	8.8	2.2	6.3	ns
LOW to OFF-state propagation delay	t_{PLZ}	DIR to A	1.2	4.1	1.2	4.1	1.1	4.1	0.9	4.1	0.8	4.1	ns
		DIR to B	2.0	14.5	2.1	13.4	1.7	8.2	2.0	7.7	1.6	5.0	ns
OFF-state to HIGH propagation delay	t_{PZH}	DIR to A ^[1]	-	26.1	-	20.9	-	13.5	-	12.6	-	9.3	ns
		DIR to B ^[1]	-	22.4	-	20.8	-	12.4	-	10.1	-	8.4	ns
OFF-state to LOW propagation delay	t_{PZL}	DIR to A ^[1]	-	31.0	-	25.5	-	15.8	-	13.2	-	10.2	ns
		DIR to B ^[1]	-	22.9	-	19.5	-	12.9	-	11.0	-	9.9	ns

Note: [1] t_{PZH} and t_{PZL} are calculated values using the formula shown in Section 6.4.

4、Testing Circuit

4.1、AC Testing Circuit

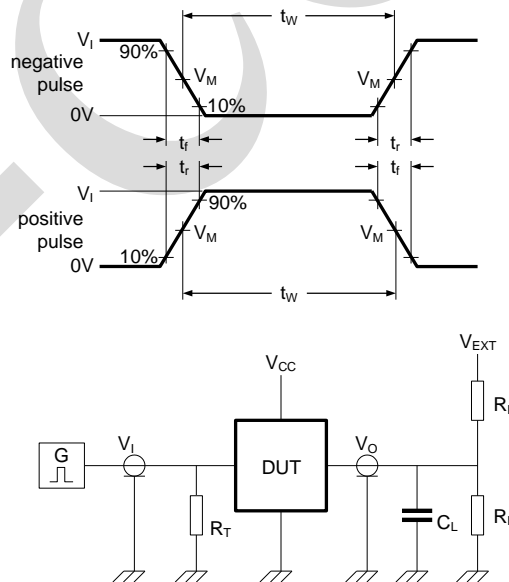

R_L =Load resistance.

C_L =Load capacitance including jig and probe capacitance.

R_T =Termination resistance.

V_{EXT} =External voltage for measuring switching times.

Figure 3. Test circuit for measuring switching times



4.2、 Test Data

Supply voltage	Input		Load		V_{EXT}		
$V_{CC(A)}, V_{CC(B)}$	$V_I^{[1]}$	$\Delta t/\Delta V^{[2]}$	C_L	R_L	t_{PLH}, t_{PHL}	t_{PZH}, t_{PHZ}	$t_{PZL}, t_{PLZ}^{[3]}$
1.2V to 5.5V	V_{CCI}	$\leq 1.0\text{ns/V}$	15pF	2k Ω	open	GND	$2V_{CCO}$

Note:

[1] V_{CCI} is the supply voltage associated with the data input port.

[2] $dV/dt \geq 1.0\text{V/ns}$.

[3] V_{CCO} is the supply voltage associated with the output port.

4.3、 AC Testing Waveforms

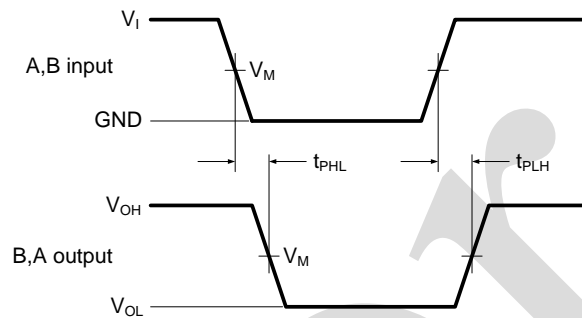

V_{OL} and V_{OH} are typical output voltage levels that occur with the output load.

Figure 4. The data input (A, B) to output (B, A) propagation delay times

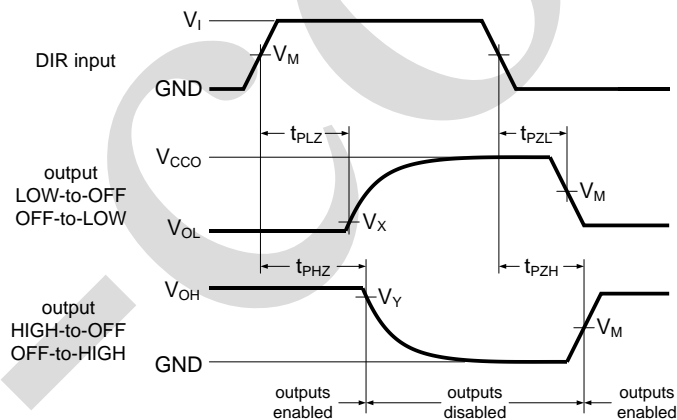

V_{OL} and V_{OH} are typical output voltage levels that occur with the output load.

Figure 5. Enable and disable times

4.4、 Measurement Points

Supply voltage	Input ^[1]	Output ^[2]		
$V_{CC(A)}, V_{CC(B)}$	V_M	V_M	V_X	V_Y
1.2V to 1.6V	$0.5V_{CCI}$	$0.5V_{CCO}$	$V_{OL}+0.1\text{V}$	$V_{OH}-0.1\text{V}$
1.65V to 2.7V	$0.5V_{CCI}$	$0.5V_{CCO}$	$V_{OL}+0.15\text{V}$	$V_{OH}-0.15\text{V}$
3.0V to 5.5V	$0.5V_{CCI}$	$0.5V_{CCO}$	$V_{OL}+0.3\text{V}$	$V_{OH}-0.3\text{V}$

Note:

[1] V_{CCI} is the supply voltage associated with the data input port.

[2] V_{CCO} is the supply voltage associated with the output port.



5、Characteristic Curve

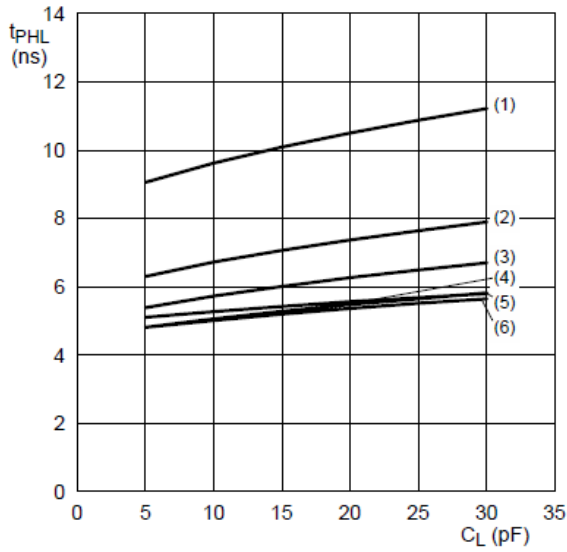

a. HIGH to LOW propagation delay (A to B)

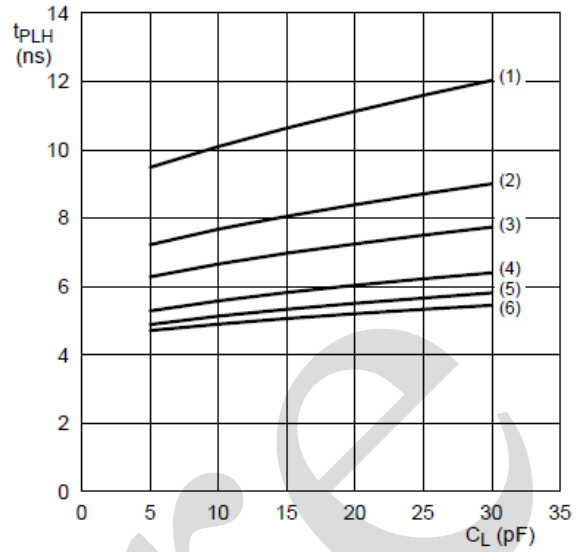

b. LOW to HIGH propagation delay (A to B)

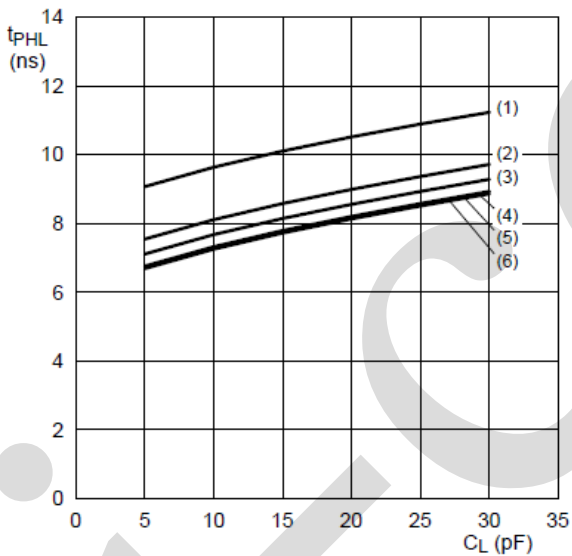

c. HIGH to LOW propagation delay (B to A)

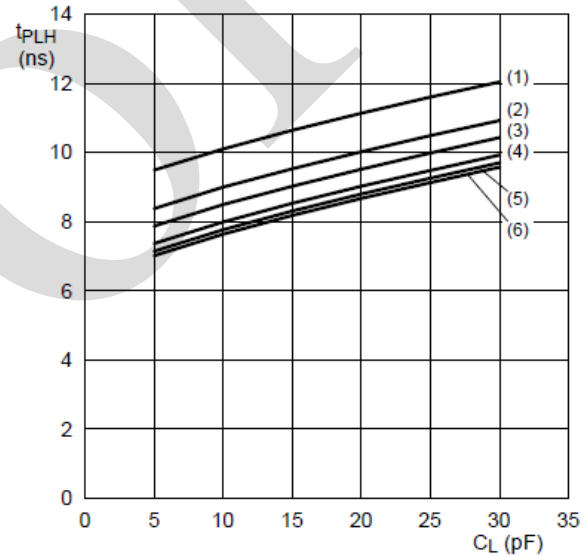

d. LOW to HIGH propagation delay (B to A)

- (1) $V_{CC(B)}=1.2V$.
- (2) $V_{CC(B)}=1.5V$.
- (3) $V_{CC(B)}=1.8V$.
- (4) $V_{CC(B)}=2.5V$.
- (5) $V_{CC(B)}=3.3V$.
- (6) $V_{CC(B)}=5.0V$.

Figure 6. Typical propagation delay versus load capacitance; $T_{amb}=25^{\circ}C$; $V_{CC(A)}=1.2V$

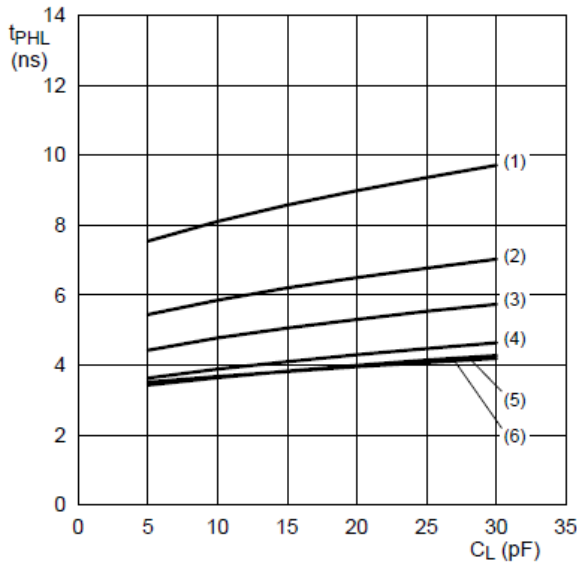

a. HIGH to LOW propagation delay (A to B)

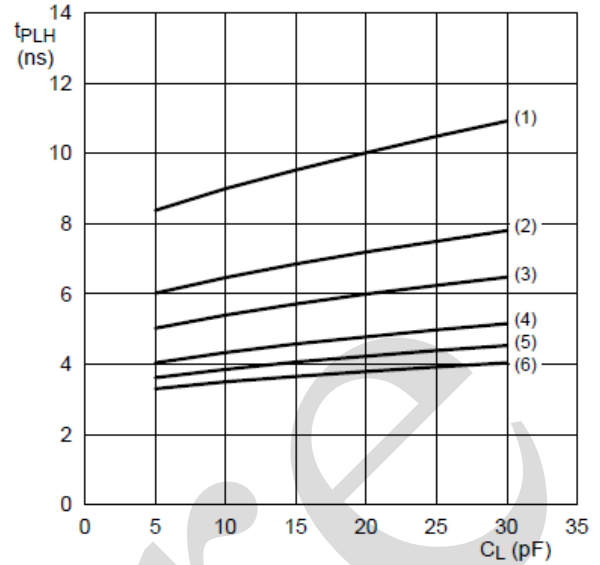

b. LOW to HIGH propagation delay (A to B)

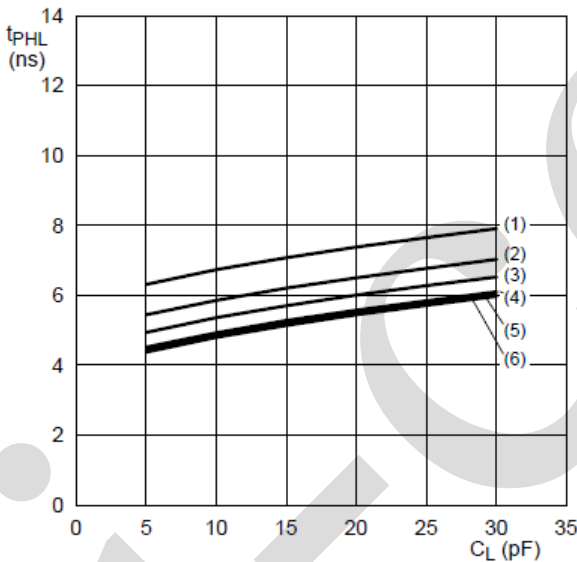

c. HIGH to LOW propagation delay (B to A)

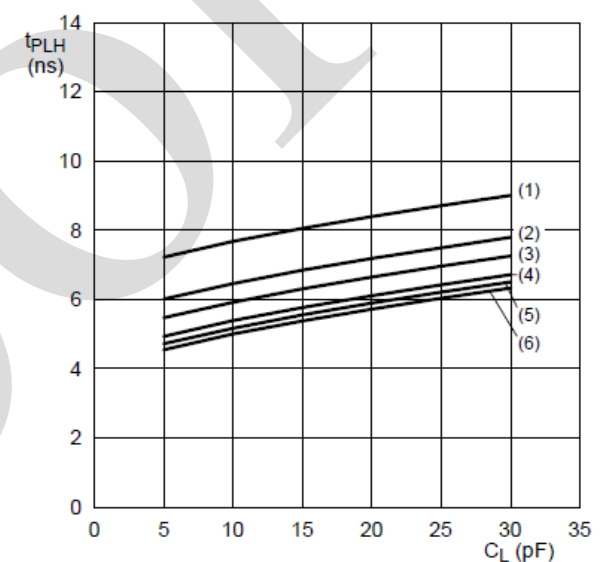

d. LOW to HIGH propagation delay (B to A)

- (1) $V_{CC(B)}=1.2V$.
- (2) $V_{CC(B)}=1.5V$.
- (3) $V_{CC(B)}=1.8V$.
- (4) $V_{CC(B)}=2.5V$.
- (5) $V_{CC(B)}=3.3V$.
- (6) $V_{CC(B)}=5.0V$.

Figure 7. Typical propagation delay versus load capacitance; $T_{amb}=25^{\circ}C$; $V_{CC(A)}=1.5V$

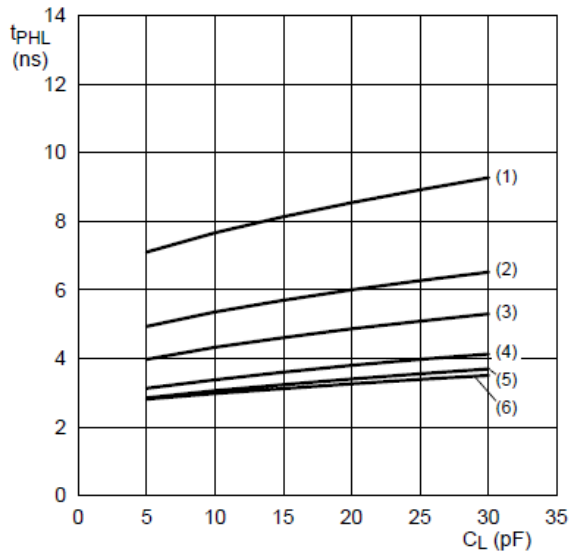

a. HIGH to LOW propagation delay (A to B)

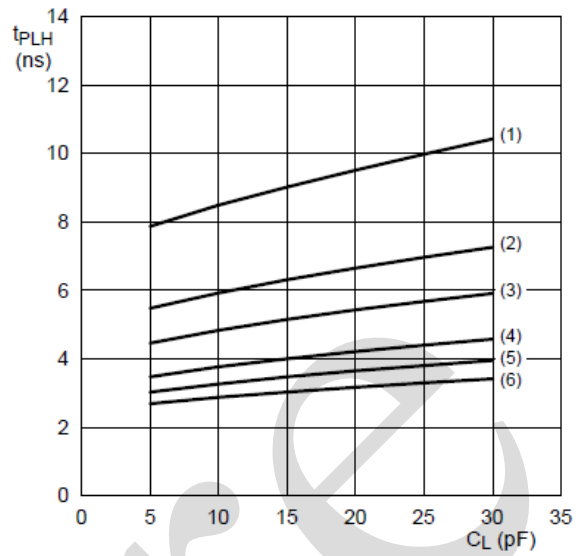

b. LOW to HIGH propagation delay (A to B)

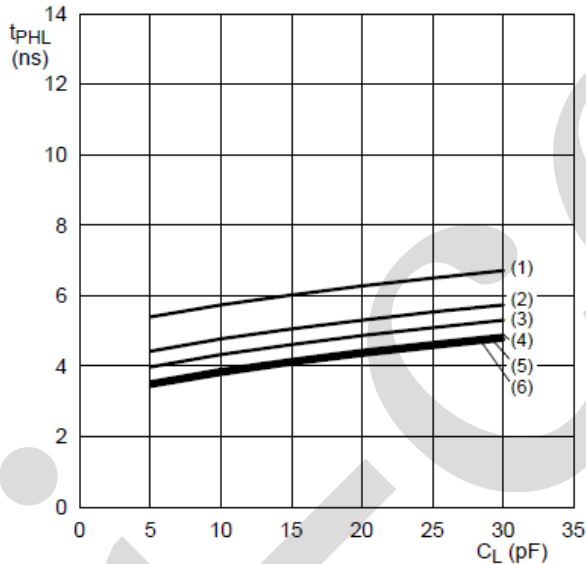

c. HIGH to LOW propagation delay (B to A)

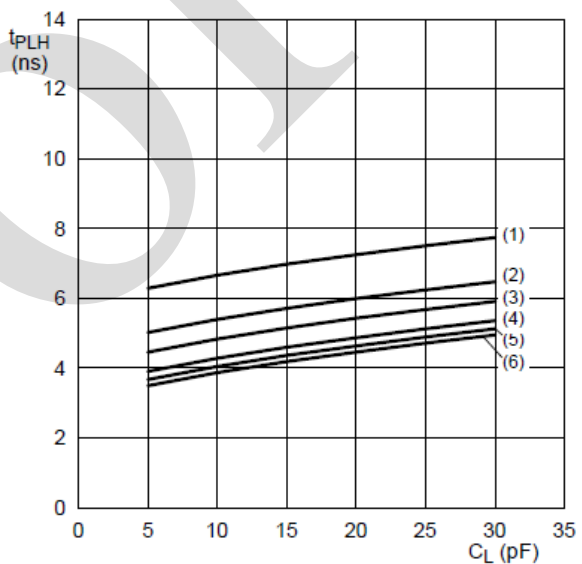

d. LOW to HIGH propagation delay (B to A)

- (1) $V_{CC(B)}=1.2V$.
- (2) $V_{CC(B)}=1.5V$.
- (3) $V_{CC(B)}=1.8V$.
- (4) $V_{CC(B)}=2.5V$.
- (5) $V_{CC(B)}=3.3V$.
- (6) $V_{CC(B)}=5.0V$.

Figure 8. Typical propagation delay versus load capacitance; $T_{amb}=25^{\circ}C$; $V_{CC(A)}=1.8V$

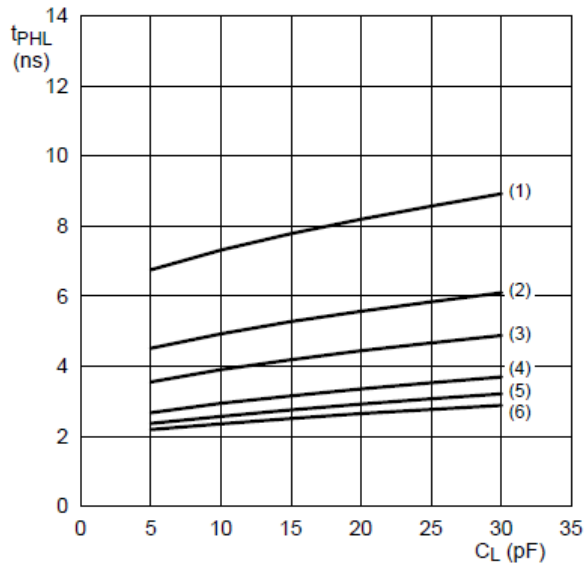

a. HIGH to LOW propagation delay (A to B)

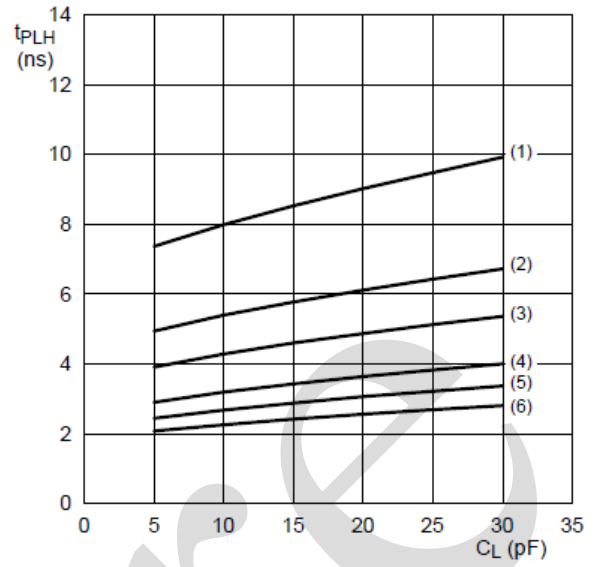

b. LOW to HIGH propagation delay (A to B)

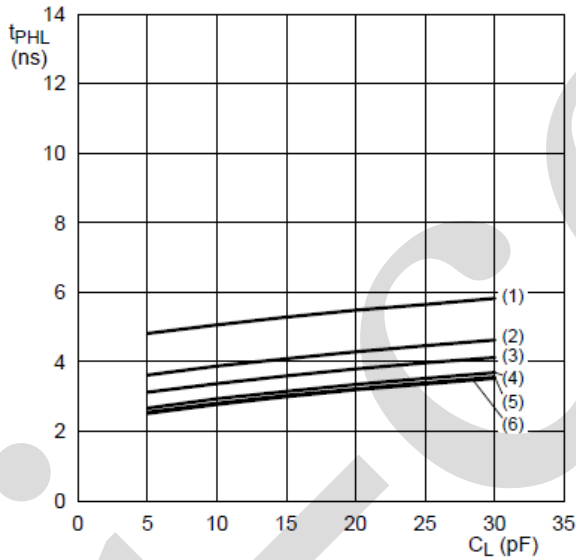

c. HIGH to LOW propagation delay (B to A)

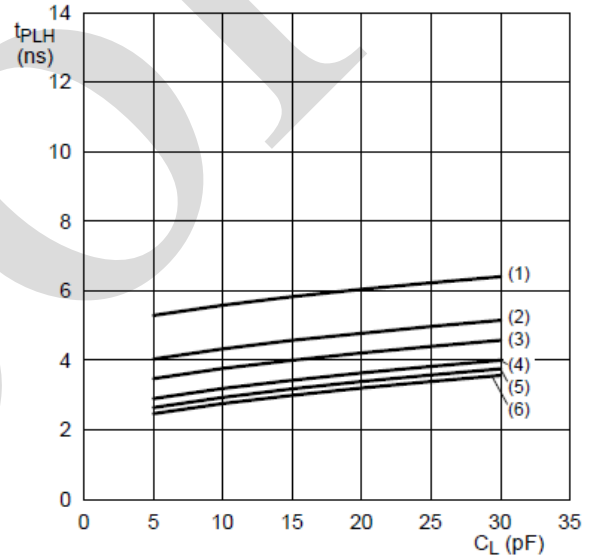

d. LOW to HIGH propagation delay (B to A)

- (1) $V_{CC(B)}=1.2V$.
- (2) $V_{CC(B)}=1.5V$.
- (3) $V_{CC(B)}=1.8V$.
- (4) $V_{CC(B)}=2.5V$.
- (5) $V_{CC(B)}=3.3V$.
- (6) $V_{CC(B)}=5.0V$.

Figure 9. Typical propagation delay versus load capacitance; $T_{amb}=25^{\circ}C$; $V_{CC(A)}=2.5V$

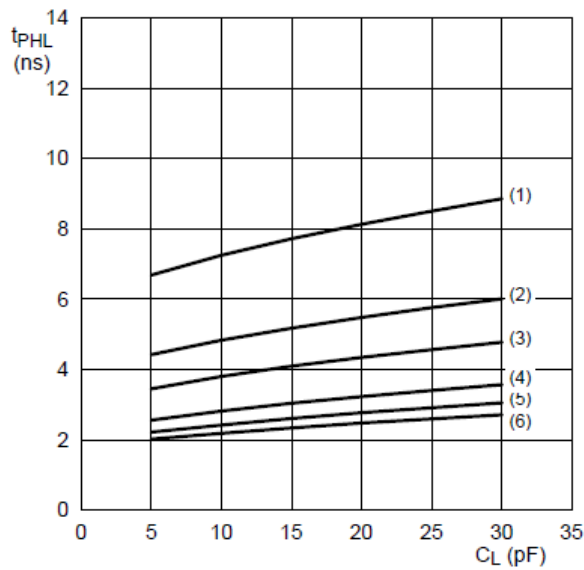

a. HIGH to LOW propagation delay (A to B)

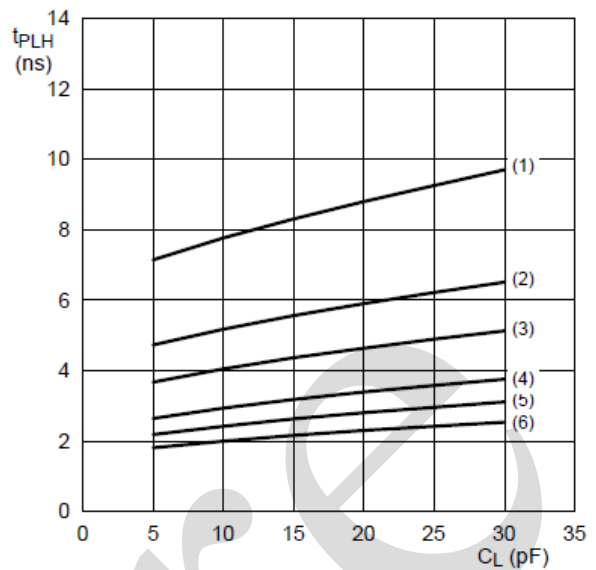

b. LOW to HIGH propagation delay (A to B)

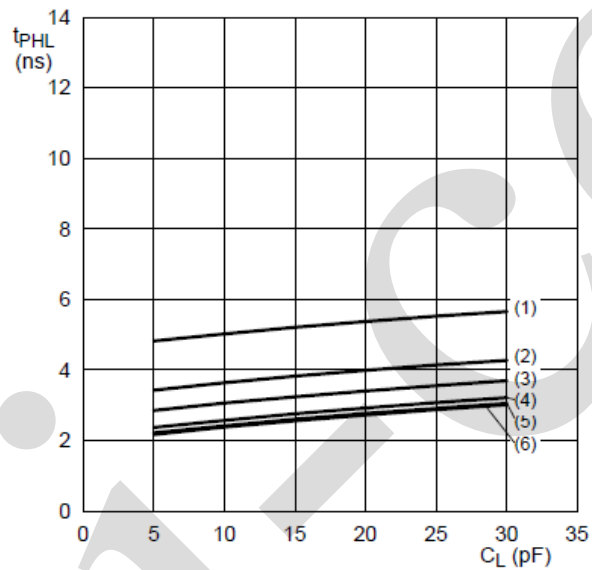

c. HIGH to LOW propagation delay (B to A)

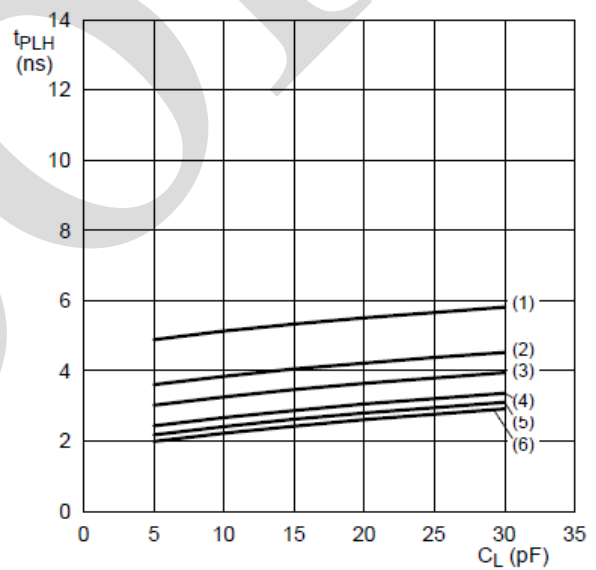

d. LOW to HIGH propagation delay (B to A)

- (1) $V_{CC(B)}=1.2V$.
- (2) $V_{CC(B)}=1.5V$.
- (3) $V_{CC(B)}=1.8V$.
- (4) $V_{CC(B)}=2.5V$.
- (5) $V_{CC(B)}=3.3V$.
- (6) $V_{CC(B)}=5.0V$.

Figure 10. Typical propagation delay versus load capacitance; $T_{amb}=25^{\circ}C$; $V_{CC(A)}=3.3V$

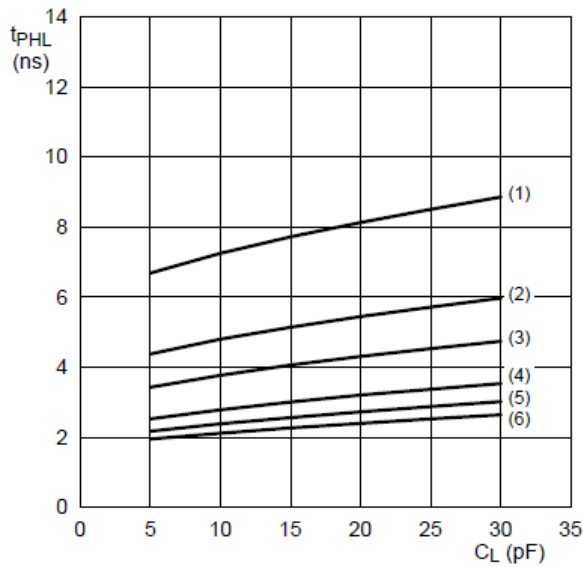

a. HIGH to LOW propagation delay (A to B)

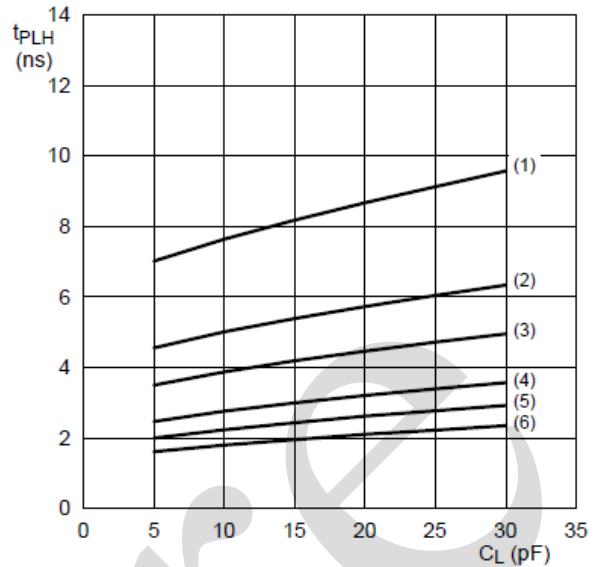

b. LOW to HIGH propagation delay (A to B)

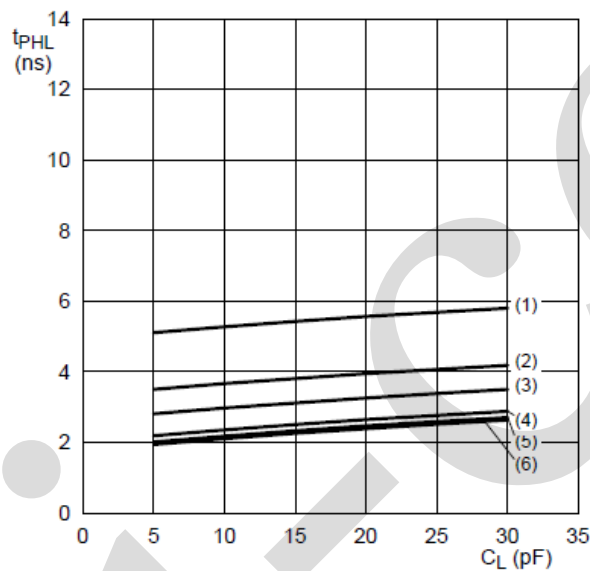

c. HIGH to LOW propagation delay (B to A)

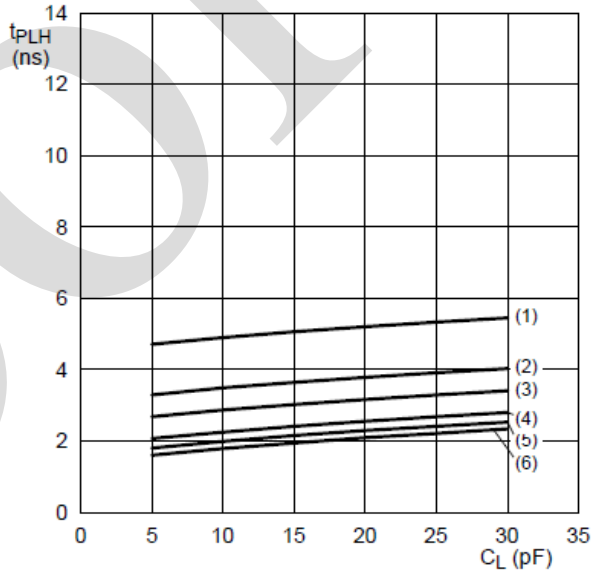

d. LOW to HIGH propagation delay (B to A)

- (1) $V_{CC(B)}=1.2V$.
- (2) $V_{CC(B)}=1.5V$.
- (3) $V_{CC(B)}=1.8V$.
- (4) $V_{CC(B)}=2.5V$.
- (5) $V_{CC(B)}=3.3V$.
- (6) $V_{CC(B)}=5.0V$.

Figure 11. Typical propagation delay versus load capacitance; $T_{amb}=25^{\circ}C$; $V_{CC(A)}=5.0V$



6、Typical Application Circuit And Application Note

6.1、Unidirectional Logic Level-shifting Application

The circuit given in Figure 12 is an example of the AiP74LVC1T45; AiP74LVCH1T45 being used in a unidirectional logic level-shifting application.

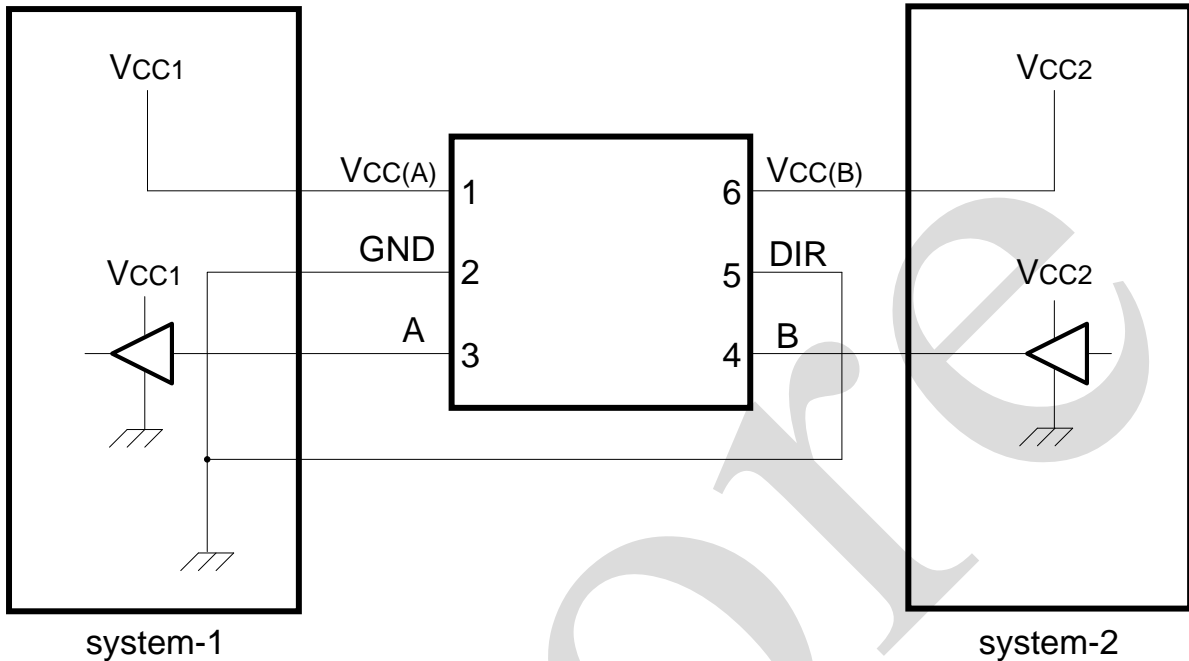

Figure 12. Unidirectional logic level-shifting application

Table 1. Description of unidirectional logic level-shifting application

Pin	Name	Function	Description
1	V _{CC(A)}	V _{CC1}	supply voltage of system-1 (1.2V to 5.5V)
2	GND	GND	device GND
3	A	OUT	output level depends on V _{CC1} voltage
4	B	IN	input threshold value depends on V _{CC2} voltage
5	DIR	DIR	the GND (LOW level) determines B port to A port direction
6	V _{CC(B)}	V _{CC2}	supply voltage of system-2 (1.2V to 5.5V)



6.2、 Bidirectional Logic Level-shifting Application

Figure 13 shows the AiP74LVC1T45; AiP74LVCH1T45 being used in a bidirectional logic level-shifting application. Since the device does not have an output enable pin, the system designer should take precautions to avoid bus contention between system-1 and system-2 when changing directions.

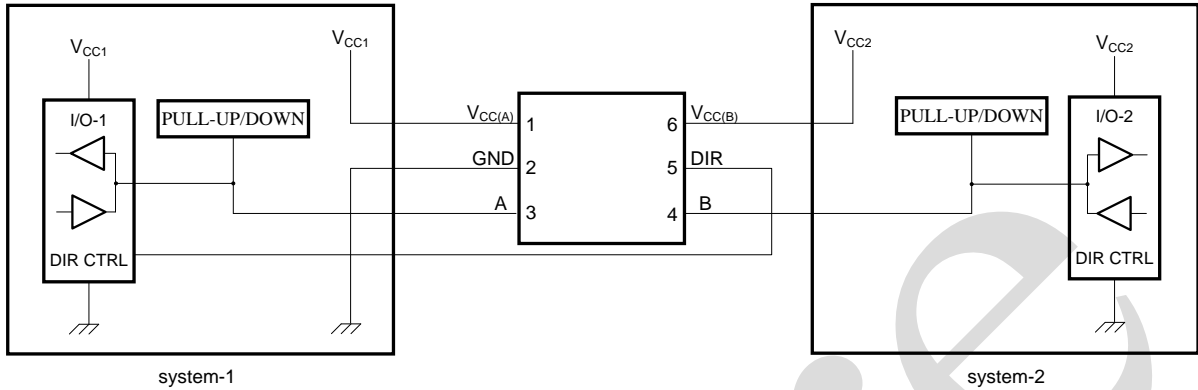

Pull-up or pull-down only needed for AiP74LVC1T45.

Figure 13. Bidirectional logic level-shifting application

Table 2 gives a sequence that will illustrate data transmission from system-1 to system-2 and then from system-2 to system-1.

Table 2. Description of bidirectional logic level-shifting application

State	DIR CTRL	I/O-1	I/O-2	Description
1	H	output	input	system-1 data to system-2
2	H	Z	Z	system-2 is getting ready to send data to system-1. I/O-1 and I/O-2 are disabled. The bus-line state depends on bus hold.
3	L	Z	Z	DIR bit is set LOW. I/O-1 and I/O-2 still are disabled. The bus-line state depends on bus hold.
4	L	input	output	system-2 data to system-1

Note:

H=HIGH voltage level;

L=LOW voltage level;

Z=high-impedance OFF-state.



6.3. Power-up Considerations

The device is designed such that no special power-up sequence is required other than GND being applied first.

Table 3. Typical total supply current ($I_{CC(A)}+I_{CC(B)}$)

$V_{CC(A)}$	$V_{CC(B)}$					Unit
	0V	0.8V	2.5V	3.3V	5.0V	
0V	0	<1	<1	<1	<1	uA
1.8V	<1	<2	<2	<2	2	uA
2.5V	<1	<2	<2	<2	<2	uA
3.3V	<1	<2	<2	<2	<2	uA
5.0V	<1	2	<2	<2	<2	uA

6.4. Enable Times

Calculate the enable times for the AiP74LVC2T45; AiP74LVCH2T45 using the following formulas:

- $t_{PZH}(\text{DIR to A})=t_{PLZ}(\text{DIR to B})+t_{PLH}(\text{B to A})$
- $t_{PZL}(\text{DIR to A})=t_{PHZ}(\text{DIR to B})+t_{PHL}(\text{B to A})$
- $t_{PZH}(\text{DIR to B})=t_{PLZ}(\text{DIR to A})+t_{PLH}(\text{A to B})$
- $t_{PZL}(\text{DIR to B})=t_{PHZ}(\text{DIR to A})+t_{PHL}(\text{A to B})$

In a bidirectional application, these enable times provide the maximum delay from the time the DIR bit is switched until an output is expected. For example, if the AiP74LVC1T45; AiP74LVCH1T45 initially is transmitting from A to B, then the DIR bit is switched, the B port of the device must be disabled before presenting it with an input. After the B port has been disabled, an input signal applied to it appears on the corresponding A port after the specified propagation delay.



7、Package Information

7.1、SOT23-6

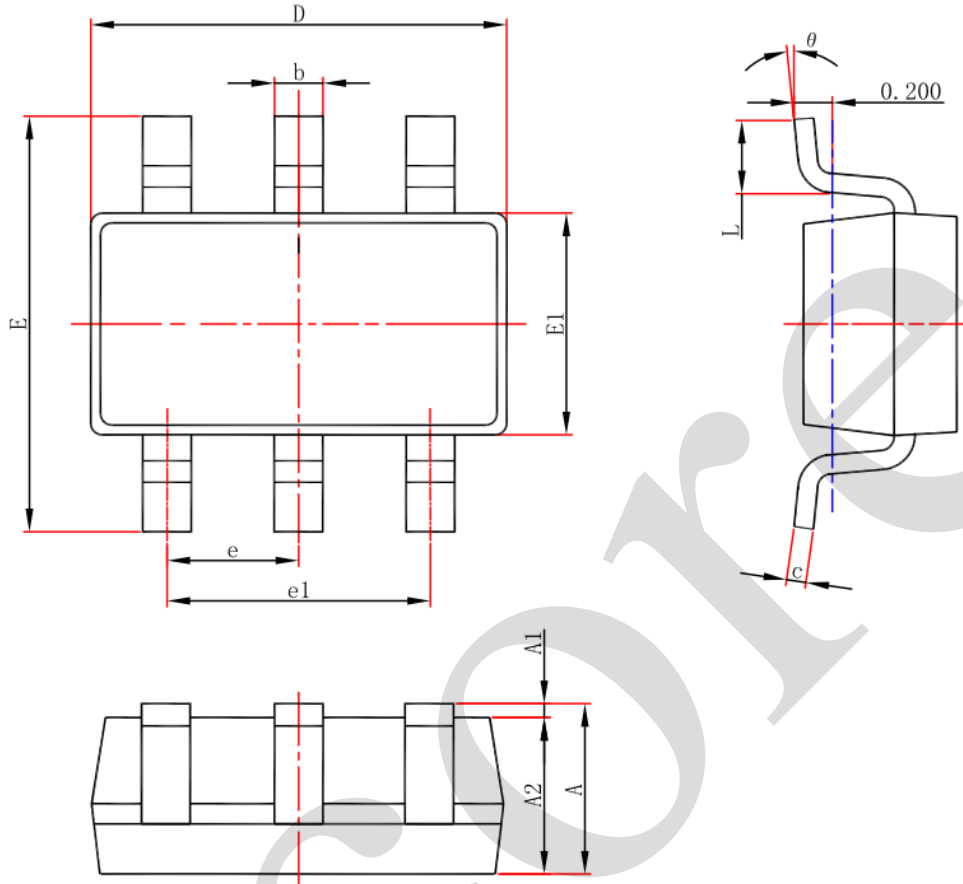

Symbol	Dimensions In Millimeters		Dimensions In Inches	
	Min.	Max.	Min.	Max.
A	1.050	1.250	0.041	0.049
A1	0.000	0.100	0.000	0.004
A2	1.050	1.150	0.041	0.045
b	0.300	0.500	0.012	0.020
c	0.100	0.200	0.004	0.008
D	2.820	3.020	0.111	0.119
E1	1.500	1.700	0.059	0.067
E	2.650	2.950	0.104	0.116
e	0.950(BSC)		0.037(BSC)	
e1	1.800	2.000	0.071	0.079
L	0.300	0.600	0.012	0.024
θ	0°	8°	0°	8°



7.2、SOT363

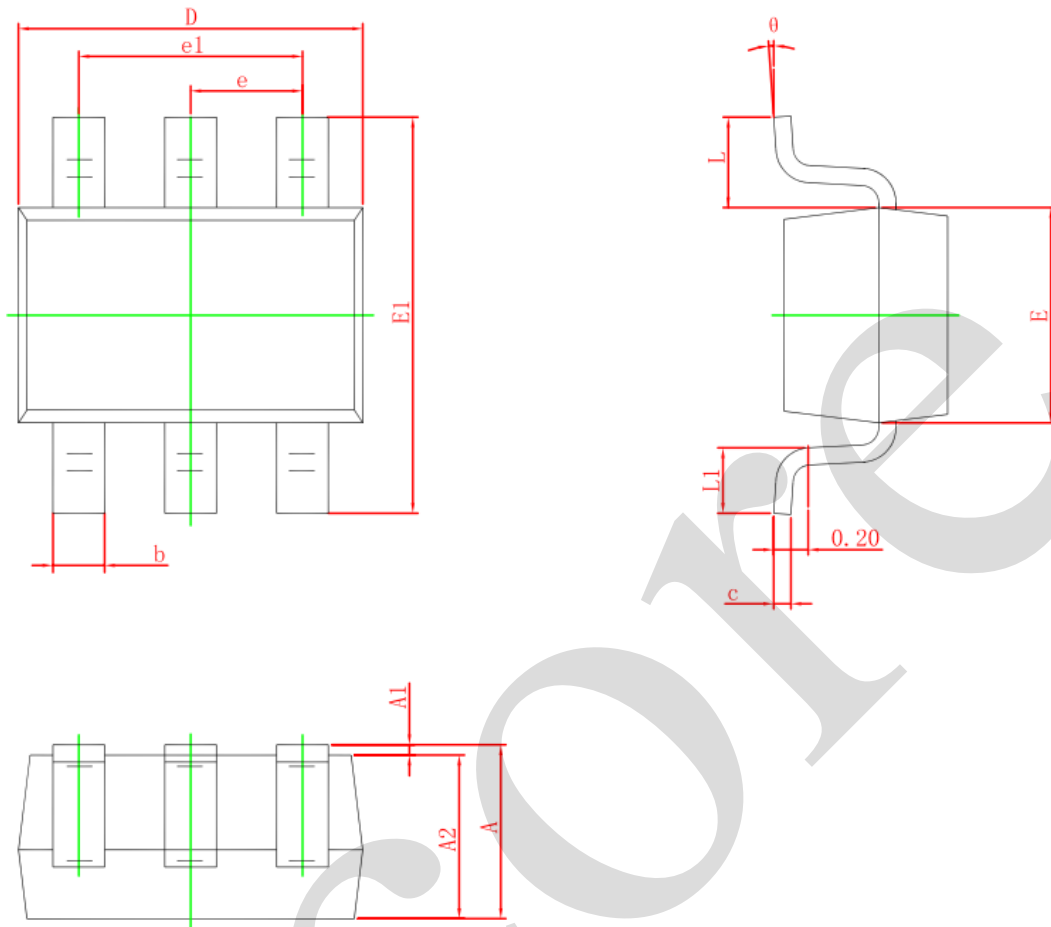

Symbol	Dimensions In Millimeters		Dimensions In Inches	
	Min.	Max.	Min.	Max.
A	0.900	1.100	0.035	0.043
A1	0.000	0.100	0.000	0.004
A2	0.900	1.000	0.035	0.039
b	0.150	0.350	0.006	0.014
c	0.080	0.150	0.003	0.006
D	2.000	2.200	0.079	0.087
E	1.150	1.350	0.045	0.053
E1	2.150	2.450	0.085	0.096
e	0.650 TYP.		0.026 TYP.	
e1	1.200	1.400	0.047	0.055
L	0.525 REF.		0.021 REF.	
L1	0.260	0.460	0.010	0.018
θ	0°	8°	0°	8°



8、 Statements And Notes

8.1、 The name and content of Hazardous substances or Elements in the product

Part name	Hazardous substances or Elements									
	Lead and lead compounds	Mercury and mercury compounds	Cadmium and cadmium compounds	Hexavalent chromium compounds	Polybrominated biphenyls	Polybrominated biphenyl ethers	Dibutyl phthalate	Butylbenzyl phthalate	Di-2-ethylhexyl phthalate	Diisobutyl phthalate
Lead frame	○	○	○	○	○	○	○	○	○	○
Plastic resin	○	○	○	○	○	○	○	○	○	○
Chip	○	○	○	○	○	○	○	○	○	○
The lead	○	○	○	○	○	○	○	○	○	○
Plastic sheet installed	○	○	○	○	○	○	○	○	○	○
explanation	<p>○: Indicates that the content of hazardous substances or elements in the detection limit of the following the SJ/T11363-2006 standard.</p> <p>×: Indicates that the content of hazardous substances or elements exceeding the SJ/T11363-2006 Standard limit requirements.</p>									

8.2、 Notion

Recommended carefully reading this information before the use of this product;

The information in this document are subject to change without notice;

This information is using to the reference only, the company is not responsible for any loss;

The company is not responsible for the any infringement of the third party patents or other rights of the responsibility.

X-ON Electronics

Largest Supplier of Electrical and Electronic Components

Click to view similar products for [Buffers & Line Drivers](#) category:

Click to view products by [I-core](#) manufacturer:

Other Similar products are found below :

[LXV200-024SW](#) [74AUP2G34FW3-7](#) [HEF4043BP](#) [NL17SG125DFT2G](#) [NLU1GT126CMUTCG](#) [CD4041UBE](#) [54FCT240CTDB](#)
[74HCT540N](#) [DS14C88N](#) [070519XB](#) [NL17SZ07P5T5G](#) [74LVC2G17FW4-7](#) [CD4502BE](#) [5962-8982101PA](#) [61446R00](#) [NL17SH17P5T5G](#)
[NLV37WZ17USG](#) [74HCT126T14-13](#) [74VHC9126FT\(BJ\)](#) [RHRXH162244K1](#) [74AUP1G34FW5-7](#) [74AUP1G07FW5-7](#) [74LVC1G126FW4-7](#)
[74LVC2G126RA3-7](#) [74LVCE1G125FZ4-7](#) [54FCT240TLB](#) [NLX3G16DMUTCG](#) [NLX2G06AMUTCG](#) [LE87100NQCT](#) [LE87285NQC](#)
[LE87290YQC](#) [LE87290YQCT](#) [74AUP1G125FW5-7](#) [NLU2G16CMUTCG](#) [MC74LCX244MN2TWG](#) [NL17SG17P5T5G](#)
[NLV74HC125ADR2G](#) [NLVHCT245ADTR2G](#) [NLVVHC1G126DFT2G](#) [EL5623IRZ](#) [ISL15102AIRZ-T13](#) [ISL1539IRZ-T13](#)
[MC100EP17MNG](#) [MC74HCT365ADR2G](#) [MC74LCX244ADTR2G](#) [NL27WZ126US](#) [NL37WZ16US](#) [NLU1G07MUTCG](#) [NLU2G07MUTCG](#)
[NLX3G17BMX1TCG](#)