



AiP74LVC2G74

Single D-type flip-flop with set and reset; positive edge trigger

Product Specification

Specification Revision History:

Version	Date	Description
2017-05-A1	2017-05	New
2021-12-A2	2021-12	Modify ordering information
2022-02-A3	2022-02	Modify ambient temperature to $-40^{\circ}\text{C}\sim+105^{\circ}\text{C}$ and add electrical characteristics of $-40^{\circ}\text{C}\sim+105^{\circ}\text{C}$
2022-03-A4	2022-03	Modify ordering information note 1



1、 General Description

The AiP74LVC2G74 is a single positive-edge triggered D-type flip-flop with individual data (D) inputs, clock (CP) inputs, set ($\bar{S}D$) and reset ($\bar{R}D$) inputs, and complementary Q and \bar{Q} outputs.

This device is fully specified for partial power-down applications using I_{OFF} . The I_{OFF} circuitry disables the output, preventing damaging backflow current through the device when it is powered down.

The set and reset are asynchronous active LOW inputs and operate independently of the clock input. Information on the data input is transferred to the Q output on the LOW-to-HIGH transition of the clock pulse. The D inputs must be stable, one set-up time prior to the LOW-to-HIGH clock transition for predictable operation.

Features:

- Wide supply voltage range from 1.65V to 5.5V
- 5 V tolerant outputs for interfacing with 5 V logic
- ± 24 mA output drive ($V_{CC}=3.0V$)
- CMOS low power consumption
- Latch-up performance exceeds 250mA
- Direct interface with TTL levels
- Inputs accept voltages up to 5V
- Specified from $-40^{\circ}C$ to $+105^{\circ}C$
- Packaging information: TSSOP8/VSSOP8

Ordering Information:

Reel packing specifications:

Part number	Packaging form	Marking code	Reel quantity	Boxed reel quantity	Notes
AiP74LVC2G74TA8.TR	TSSOP8	ARXX	3000 PCS/reel	3000 PCS/box	Dimensions of plastic enclosure: 3.0mm×3.0mm Pin spacing: 0.65mm
AiP74LVC2G74YA8.TR	VSSOP8	ARXX	3000 PCS/reel	3000 PCS/box	Dimensions of plastic enclosure: 2.0mm×2.3mm Pin spacing:0.50mm

Note 1: "XX" refers to variable content, meaning year and package batch serial number.

Note 2: If the physical information is inconsistent with the ordering information, please refer to the actual product.



2、Block Diagram And Pin Description

2.1、Block Diagram

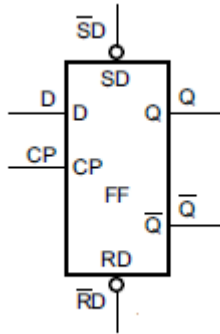

Figure 1. Logic symbol

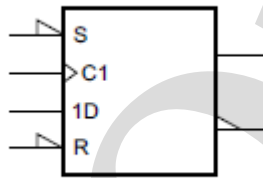

Figure 2. IEC logic symbol

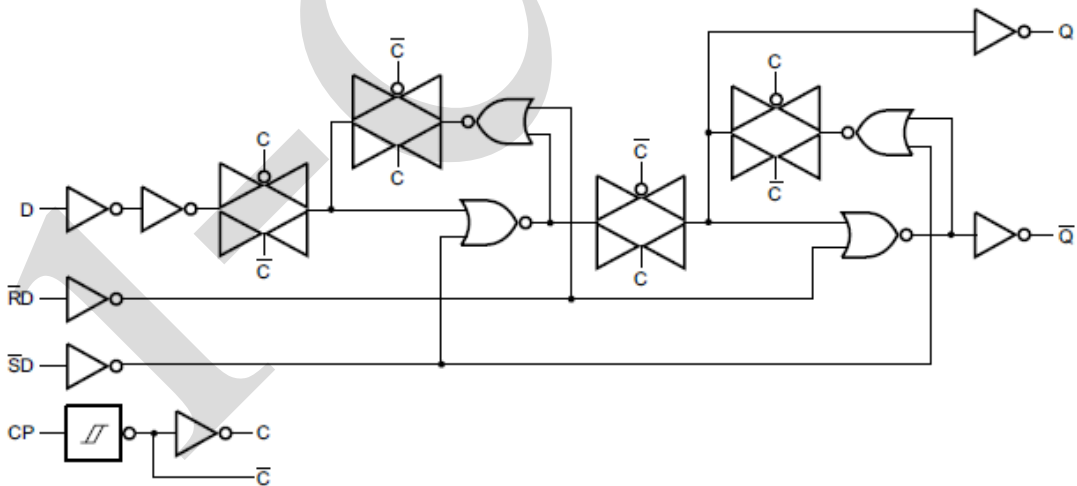
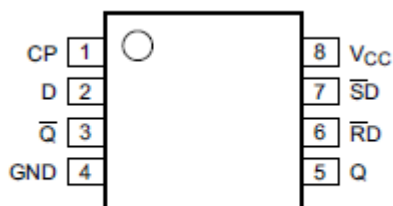

Figure 3. Logic diagram



2.2、Pin Configurations



2.3、Pin Description

Pin No.	Pin Name	Description
1	CP	clock input (LOW-to-HIGH, edge-triggered)
2	D	data input
3	\bar{Q}	complement output
4	GND	ground (0V)
5	Q	true output
6	\bar{RD}	asynchronous reset-direct input (active LOW)
7	\bar{SD}	asynchronous set-direct input (active LOW)
8	V _{CC}	supply voltage

2.4、Function Table

Function table for asynchronous operation

Input				Output	
\bar{SD}	\bar{RD}	CP	D	Q	\bar{Q}
L	H	X	X	H	L
H	L	X	X	L	H
L	L	X	X	H	H

Note: H=HIGH voltage level; L=LOW voltage level; X=don't care.

Function table for synchronous operation

Input				Output	
\bar{SD}	\bar{RD}	CP	D	Q _{n+1}	\bar{Q}_{n+1}
H	H	↑	L	L	H
H	H	↑	H	H	L

Note: H=HIGH voltage level; L=LOW voltage level; ↑=LOW-to-HIGH CP transition;
Q_{n+1}=state after the next LOW-to-HIGH CP transition.



3、Electrical Parameter

3.1、Absolute Maximum Ratings

(Voltages are referenced to GND(ground=0V), unless otherwise specified.)

Parameter	Symbol	Conditions	Min.	Max.	Unit
supply voltage	V_{CC}	-	-0.5	+6.5	V
input clamping current	I_{IK}	$V_I < 0V$	-50	-	mA
input voltage	V_I	-	-0.5	+6.5	V
output clamping current	I_{OK}	$V_O > V_{CC}$ or $V_O < 0V$	-	± 50	mA
output voltage	V_O	Active mode	-0.5	$V_{CC}+0.5$	V
		Power-down mode; $V_{CC}=0V$	-0.5	+6.5	V
output current	I_O	$V_O=0V$ to V_{CC}	-	± 50	mA
supply current	I_{CC}	-	-	100	mA
ground current	I_{GND}	-	-100	-	mA
total power dissipation	P_{tot}	-	-	300	mW
storage temperature	T_{stg}	-	-65	+150	°C
Soldering temperature	T_L	10s		250	°C

Note:

[1] For TSSOP8 package: above 55°C the value of P_{tot} derates linearly with 2.5mW/K.

[2] For VSSOP8 package: above 110°C the value of P_{tot} derates linearly at 8mW/K.

3.2、Recommended Operating Conditions

Parameter	Symbol	Conditions	Min.	Typ.	Max.	Unit
supply voltage	V_{CC}	-	1.65	-	5.5	V
input voltage	V_I	-	0	-	5.5	V
output voltage	V_O	Active mode	0	-	V_{CC}	V
		Power-down mode; $V_{CC}=0V$	0	-	5.5	V
ambient temperature	T_{amb}	-	-40	-	+105	°C
input transition rise and fall rate	$\Delta t/\Delta V$	$V_{CC}=1.65V$ to $2.7V$	-	-	20	ns/V
		$V_{CC}=2.7V$ to $5.5V$	-	-	10	ns/V



3.3. Electrical Characteristics

3.3.1. DC Characteristics 1

($T_{amb} = -40^{\circ}\text{C}$ to $+85^{\circ}\text{C}$, voltages are referenced to GND (ground=0V), unless otherwise specified.)

Parameter	Symbol	Conditions	Min.	Typ.	Max.	Unit	
HIGH-level input voltage	V_{IH}	$V_{CC}=1.65\text{V}$ to 1.95V	$0.65 \times V_{CC}$	-	-	V	
		$V_{CC}=2.3\text{V}$ to 2.7V	1.7	-	-	V	
		$V_{CC}=2.7\text{V}$ to 3.6V	2.0	-	-	V	
		$V_{CC}=4.5\text{V}$ to 5.5V	$0.7 \times V_{CC}$	-	-	V	
LOW-level input voltage	V_{IL}	$V_{CC}=1.65\text{V}$ to 1.95V	-	-	$0.35 \times V_{CC}$	V	
		$V_{CC}=2.3\text{V}$ to 2.7V	-	-	0.7	V	
		$V_{CC}=2.7\text{V}$ to 3.6V	-	-	0.8	V	
		$V_{CC}=4.5\text{V}$ to 5.5V	-	-	$0.3 \times V_{CC}$	V	
HIGH-level output voltage	V_{OH}	$V_I = V_{IH}$ or V_{IL}	$I_O = -100\mu\text{A}$; $V_{CC}=1.65\text{V}$ to 5.5V	$V_{CC} - 0.1$	-	-	V
			$I_O = -4\text{mA}$; $V_{CC}=1.65\text{V}$	1.2	1.54	-	V
			$I_O = -8\text{mA}$; $V_{CC}=2.3\text{V}$	1.9	2.15	-	V
			$I_O = -12\text{mA}$; $V_{CC}=2.7\text{V}$	2.2	2.50	-	V
			$I_O = -24\text{mA}$; $V_{CC}=3.0\text{V}$	2.3	2.62	-	V
			$I_O = -32\text{mA}$; $V_{CC}=4.5\text{V}$	3.8	4.11	-	V
LOW-level output voltage	V_{OL}	$V_I = V_{IH}$ or V_{IL}	$I_O = 100\mu\text{A}$; $V_{CC}=1.65\text{V}$ to 5.5V	-	-	0.10	V
			$I_O = 4\text{mA}$; $V_{CC}=1.65\text{V}$	-	0.07	0.45	V
			$I_O = 8\text{mA}$; $V_{CC}=2.3\text{V}$	-	0.12	0.30	V
			$I_O = 12\text{mA}$; $V_{CC}=2.7\text{V}$	-	0.17	0.40	V
			$I_O = 24\text{mA}$; $V_{CC}=3.0\text{V}$	-	0.33	0.55	V
			$I_O = 32\text{mA}$; $V_{CC}=4.5\text{V}$	-	0.39	0.55	V
input leakage current	I_I	$V_I = 5.5\text{V}$ or GND; $V_{CC} = 0\text{V}$ to 5.5V	-	± 0.1	± 1	μA	
power-off leakage current	I_{OFF}	V_I or $V_O = 5.5\text{V}$; $V_{CC} = 0\text{V}$	-	± 0.1	± 2	μA	
supply current	I_{CC}	$V_I = 5.5\text{V}$ or GND; $I_O = 0\text{A}$; $V_{CC} = 1.65\text{V}$ to 5.5V	-	0.1	4	μA	
additional supply current	ΔI_{CC}	per pin; $V_I = V_{CC} - 0.6\text{V}$; $I_O = 0\text{A}$; $V_{CC} = 2.3\text{V}$ to 5.5V	-	5	500	μA	
input capacitance	C_I	-	-	4.0	-	pF	

Note: All typical values are measured at $T_{amb} = 25^{\circ}\text{C}$.



3.3.2、DC Characteristics 2

($T_{amb} = -40^{\circ}\text{C}$ to $+105^{\circ}\text{C}$, voltages are referenced to GND (ground=0V), unless otherwise specified.)

Parameter	Symbol	Conditions	Min.	Typ.	Max.	Unit	
HIGH-level input voltage	V_{IH}	$V_{CC}=1.65\text{V to }1.95\text{V}$	$0.65 \times V_{CC}$	-	-	V	
		$V_{CC}=2.3\text{V to }2.7\text{V}$	1.7	-	-	V	
		$V_{CC}=2.7\text{V to }3.6\text{V}$	2.0	-	-	V	
		$V_{CC}=4.5\text{V to }5.5\text{V}$	$0.7 \times V_{CC}$	-	-	V	
LOW-level input voltage	V_{IL}	$V_{CC}=1.65\text{V to }1.95\text{V}$	-	-	$0.35 \times V_{CC}$	V	
		$V_{CC}=2.3\text{V to }2.7\text{V}$	-	-	0.7	V	
		$V_{CC}=2.7\text{V to }3.6\text{V}$	-	-	0.8	V	
		$V_{CC}=4.5\text{V to }5.5\text{V}$	-	-	$0.3 \times V_{CC}$	V	
HIGH-level output voltage	V_{OH}	$V_I = V_{IH} \text{ or } V_{IL}$	$I_O = -100\mu\text{A}; V_{CC}=1.65\text{V to }5.5\text{V}$	$V_{CC}-0.1$	-	-	V
			$I_O = -4\text{mA}; V_{CC}=1.65\text{V}$	0.95	-	-	V
			$I_O = -8\text{mA}; V_{CC}=2.3\text{V}$	1.7	-	-	V
			$I_O = -12\text{mA}; V_{CC}=2.7\text{V}$	1.9	-	-	V
			$I_O = -24\text{mA}; V_{CC}=3.0\text{V}$	2.0	-	-	V
			$I_O = -32\text{mA}; V_{CC}=4.5\text{V}$	3.4	-	-	V
LOW-level output voltage	V_{OL}	$V_I = V_{IH} \text{ or } V_{IL}$	$I_O = 100\mu\text{A}; V_{CC}=1.65\text{V to }5.5\text{V}$	-	-	0.10	V
			$I_O = 4\text{mA}; V_{CC}=1.65\text{V}$	-	-	0.70	V
			$I_O = 8\text{mA}; V_{CC}=2.3\text{V}$	-	-	0.45	V
			$I_O = 12\text{mA}; V_{CC}=2.7\text{V}$	-	-	0.60	V
			$I_O = 24\text{mA}; V_{CC}=3.0\text{V}$	-	-	0.80	V
			$I_O = 32\text{mA}; V_{CC}=4.5\text{V}$	-	-	0.80	V
input leakage current	I_I	$V_I = 5.5\text{V or GND}; V_{CC} = 0\text{V to }5.5\text{V}$	-	-	± 1	μA	
power-off leakage current	I_{OFF}	$V_I \text{ or } V_O = 5.5\text{V}; V_{CC} = 0\text{V}$	-	-	± 2	μA	
supply current	I_{CC}	$V_I = 5.5\text{V or GND}; I_O = 0\text{A}; V_{CC} = 1.65\text{V to }5.5\text{V}$	-	-	4	μA	
additional supply current	ΔI_{CC}	per pin; $V_I = V_{CC} - 0.6\text{V}; I_O = 0\text{A}; V_{CC} = 2.3\text{V to }5.5\text{V}$	-	-	500	μA	

Note: All typical values are measured at $T_{amb} = 25^{\circ}\text{C}$.



3.3.3. AC Characteristics 1

($T_{amb} = -40^{\circ}\text{C}$ to $+85^{\circ}\text{C}$, voltages are referenced to GND (ground=0V), unless otherwise specified.)

Parameter	Symbol	Conditions	Min.	Typ.	Max.	Unit	
propagation delay	t_{pd}	CP to Q, \bar{Q} ; see Figure 5	$V_{CC}=1.65\text{V}$ to 1.95V	1.5	6.0	13.4	ns
			$V_{CC}=2.3\text{V}$ to 2.7V	1.0	3.5	7.1	ns
			$V_{CC}=2.7\text{V}$	1.0	3.5	7.1	ns
			$V_{CC}=3.0\text{V}$ to 3.6V	1.0	3.5	5.9	ns
			$V_{CC}=4.5\text{V}$ to 5.5V	1.0	2.5	4.1	ns
		\bar{SD} to Q, \bar{Q} ; see Figure 6	$V_{CC}=1.65\text{V}$ to 1.95V	1.5	6.0	12.9	ns
			$V_{CC}=2.3\text{V}$ to 2.7V	1.0	3.5	7.0	ns
			$V_{CC}=2.7\text{V}$	1.0	3.5	7.0	ns
			$V_{CC}=3.0\text{V}$ to 3.6V	1.0	3.0	5.9	ns
			$V_{CC}=4.5\text{V}$ to 5.5V	1.0	2.5	4.1	ns
		\bar{RD} to Q, \bar{Q} ; see Figure 6	$V_{CC}=1.65\text{V}$ to 1.95V	1.5	5.0	12.9	ns
			$V_{CC}=2.3\text{V}$ to 2.7V	1.0	3.5	7.0	ns
			$V_{CC}=2.7\text{V}$	1.0	3.5	7.0	ns
			$V_{CC}=3.0\text{V}$ to 3.6V	1.0	3.0	5.9	ns
			$V_{CC}=4.5\text{V}$ to 5.5V	1.0	2.5	4.1	ns
pulse width	t_w	CP HIGH or LOW; see Figure 5	$V_{CC}=1.65\text{V}$ to 1.95V	6.2	-	-	ns
			$V_{CC}=2.3\text{V}$ to 2.7V	2.7	-	-	ns
			$V_{CC}=2.7\text{V}$	2.7	-	-	ns
			$V_{CC}=3.0\text{V}$ to 3.6V	2.7	1.3	-	ns
			$V_{CC}=4.5\text{V}$ to 5.5V	2.0	-	-	ns
		\bar{SD} and \bar{RD} LOW; see Figure 6	$V_{CC}=1.65\text{V}$ to 1.95V	6.2	-	-	ns
			$V_{CC}=2.3\text{V}$ to 2.7V	2.7	-	-	ns
			$V_{CC}=2.7\text{V}$	2.7	-	-	ns
			$V_{CC}=3.0\text{V}$ to 3.6V	2.7	1.6	-	ns
			$V_{CC}=4.5\text{V}$ to 5.5V	2.0	-	-	ns
recovery time	t_{rec}	\bar{SD} or \bar{RD} ; see Figure 6	$V_{CC}=1.65\text{V}$ to 1.95V	1.9	-	-	ns
			$V_{CC}=2.3\text{V}$ to 2.7V	1.4	-	-	ns
			$V_{CC}=2.7\text{V}$	1.3	-	-	ns
			$V_{CC}=3.0\text{V}$ to 3.6V	+1.2	-3.0	-	ns
			$V_{CC}=4.5\text{V}$ to 5.5V	1.0	-	-	ns
set-up time	t_{su}	D to CP; see Figure 5	$V_{CC}=1.65\text{V}$ to 1.95V	2.9	-	-	ns
			$V_{CC}=2.3\text{V}$ to 2.7V	1.7	-	-	ns
			$V_{CC}=2.7\text{V}$	1.7	-	-	ns
			$V_{CC}=3.0\text{V}$ to 3.6V	1.3	0.5	-	ns
			$V_{CC}=4.5\text{V}$ to 5.5V	1.1	-	-	ns
hold time	t_h	D to CP; see Figure 5	$V_{CC}=1.65\text{V}$ to 1.95V	1.5	-	-	ns
			$V_{CC}=2.3\text{V}$ to 2.7V	1.0	-	-	ns
			$V_{CC}=2.7\text{V}$	1.0	-	-	ns
			$V_{CC}=3.0\text{V}$ to 3.6V	1.0	0.6	-	ns
			$V_{CC}=4.5\text{V}$ to 5.5V	1.0	-	-	ns
maximum frequency	f_{max}	CP; see Figure 5	$V_{CC}=1.65\text{V}$ to 1.95V	80	-	-	MHz
			$V_{CC}=2.3\text{V}$ to 2.7V	175	-	-	MHz



			V _{CC} =2.7V	175	-	-	MHz
			V _{CC} =3.0V to 3.6V	175	280	-	MHz
			V _{CC} =4.5V to 5.5V	200	-	-	MHz
Power dissipation capacitance	C _{PD}	V _{CC} =3.3V; V _I =GND to V _{CC}		-	15	-	pF

Note:

[1] Typical values are measured at T_{amb}=25°C and V_{CC}=1.8V, 2.5V, 2.7V, 3.3V and 5.0V respectively.

[2] t_{pd} is the same as t_{PLH} and t_{PHL}.

[3] C_{PD} is used to determine the dynamic power dissipation (P_D in uW).

$$P_D = (C_{PD} \times V_{CC}^2 \times f_i \times N) + \sum (C_L \times V_{CC}^2 \times f_o) \text{ where:}$$

f_i=input frequency in MHz;

f_o=output frequency in MHz;

C_L=output load capacitance in pF;

V_{CC}=supply voltage in V;

N=number of inputs switching;

$\sum (C_L \times V_{CC}^2 \times f_o)$ =sum of outputs.

3.3.4. AC Characteristics 2

(T_{amb}=-40°C to +105°C, voltages are referenced to GND (ground=0V), unless otherwise specified.)

Parameter	Symbol	Conditions	Min.	Typ.	Max.	Unit	
propagation delay	t _{pd}	CP to Q, \bar{Q} ; see Figure 5	V _{CC} =1.65V to 1.95V	1.5	-	13.4	ns
			V _{CC} =2.3V to 2.7V	1.0	-	7.1	ns
			V _{CC} =2.7V	1.0	-	7.1	ns
			V _{CC} =3.0V to 3.6V	1.0	-	5.9	ns
			V _{CC} =4.5V to 5.5V	1.0	-	4.1	ns
		$\bar{S}D$ to Q, \bar{Q} ; see Figure 6	V _{CC} =1.65V to 1.95V	1.5	-	12.9	ns
			V _{CC} =2.3V to 2.7V	1.0	-	7.0	ns
			V _{CC} =2.7V	1.0	-	7.0	ns
			V _{CC} =3.0V to 3.6V	1.0	-	5.9	ns
		$\bar{R}D$ to Q, \bar{Q} ; see Figure 6	V _{CC} =4.5V to 5.5V	1.0	-	4.1	ns
			V _{CC} =1.65V to 1.95V	1.5	-	12.9	ns
			V _{CC} =2.3V to 2.7V	1.0	-	7.0	ns
V _{CC} =2.7V	1.0		-	7.0	ns		
pulse width	t _w	CP HIGH or LOW; see Figure 5	V _{CC} =1.65V to 1.95V	6.2	-	-	ns
			V _{CC} =2.3V to 2.7V	2.7	-	-	ns
			V _{CC} =2.7V	2.7	-	-	ns
			V _{CC} =3.0V to 3.6V	2.7	-	-	ns
			V _{CC} =4.5V to 5.5V	2.0	-	-	ns
		$\bar{S}D$ and $\bar{R}D$ LOW; see Figure 6	V _{CC} =1.65V to 1.95V	6.2	-	-	ns
			V _{CC} =2.3V to 2.7V	2.7	-	-	ns
			V _{CC} =2.7V	2.7	-	-	ns
		V _{CC} =3.0V to 3.6V	2.7	-	-	ns	



recovery time	t_{rec}	\overline{SD} or \overline{RD} ; see Figure 6	$V_{CC}=4.5V$ to $5.5V$	2.0	-	-	ns
			$V_{CC}=1.65V$ to $1.95V$	1.9	-	-	ns
			$V_{CC}=2.3V$ to $2.7V$	1.4	-	-	ns
			$V_{CC}=2.7V$	1.3	-	-	ns
			$V_{CC}=3.0V$ to $3.6V$	+1.2	-	-	ns
			$V_{CC}=4.5V$ to $5.5V$	1.0	-	-	ns
set-up time	t_{su}	D to CP; see Figure 5	$V_{CC}=1.65V$ to $1.95V$	2.9	-	-	ns
			$V_{CC}=2.3V$ to $2.7V$	1.7	-	-	ns
			$V_{CC}=2.7V$	1.7	-	-	ns
			$V_{CC}=3.0V$ to $3.6V$	1.3	-	-	ns
			$V_{CC}=4.5V$ to $5.5V$	1.1	-	-	ns
hold time	t_h	D to CP; see Figure 5	$V_{CC}=1.65V$ to $1.95V$	1.5	-	-	ns
			$V_{CC}=2.3V$ to $2.7V$	1.0	-	-	ns
			$V_{CC}=2.7V$	1.0	-	-	ns
			$V_{CC}=3.0V$ to $3.6V$	1.0	-	-	ns
			$V_{CC}=4.5V$ to $5.5V$	1.0	-	-	ns
maximum frequency	f_{max}	CP; see Figure 5	$V_{CC}=1.65V$ to $1.95V$	80	-	-	MHz
			$V_{CC}=2.3V$ to $2.7V$	175	-	-	MHz
			$V_{CC}=2.7V$	175	-	-	MHz
			$V_{CC}=3.0V$ to $3.6V$	175	-	-	MHz
			$V_{CC}=4.5V$ to $5.5V$	200	-	-	MHz

Note:

[1] Typical values are measured at $T_{amb}=25^{\circ}C$ and $V_{CC}=1.8V, 2.5V, 2.7V, 3.3V$ and $5.0V$ respectively.

[2] t_{pd} is the same as t_{PLH} and t_{PHL} .

4、Testing Circuit

4.1、AC Testing Circuit

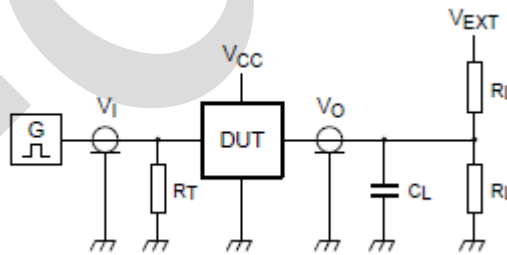

Figure 4. Test circuit for measuring switching times

Definitions for test circuit:

R_L =Load resistance.

C_L =Load capacitance including jig and probe capacitance.

R_T =Termination resistance; should be equal to the output impedance Z_o of the pulse generator.

V_{EXT} =External voltage for measuring switching times.



4.2、 AC Testing Waveforms

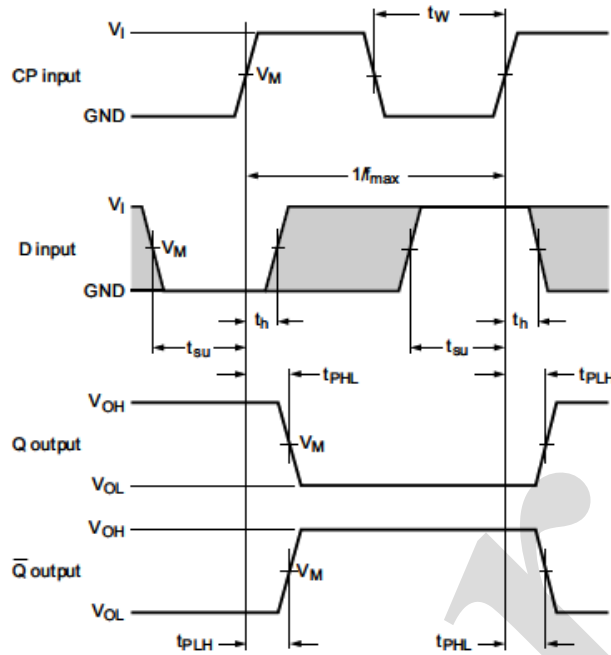

Figure 5. The clock input (CP) to output (Q, \bar{Q}) propagation delays, the clock pulse width, the D to CP set-up, the CP to D hold times and the maximum frequency

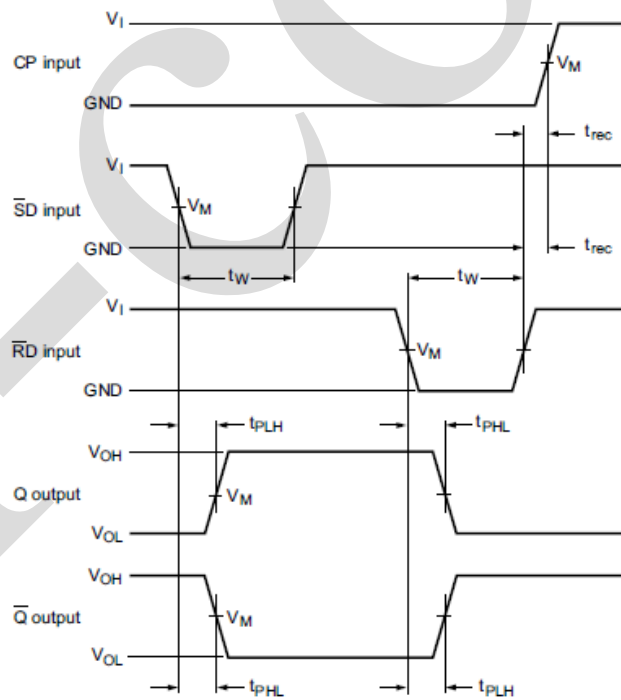

Figure 6. The set (\bar{SD}) and reset (\bar{RD}) input to output (Q, \bar{Q}) propagation delays, the set and reset pulse widths and the \bar{RD} to CP recovery time



4.3、Measurement Points

Supply voltage	Input	Output
V_{CC}	V_M	V_M
1.65V to 1.95V	$0.5 \times V_{CC}$	$0.5 \times V_{CC}$
2.3V to 2.7V	$0.5 \times V_{CC}$	$0.5 \times V_{CC}$
2.7V	1.5V	1.5V
3.0V to 3.6V	1.5V	1.5V
4.5V to 5.5V	$0.5 \times V_{CC}$	$0.5 \times V_{CC}$

4.4、Test Data

Supply voltage	Input		Load		V_{EXT}		
	V_I	$t_r = t_f$	C_L	R_L	t_{PLH}, t_{PHL}	t_{PZH}, t_{PHZ}	t_{PZL}, t_{PLZ}
1.65V to 1.95V	V_{CC}	$\leq 2.0ns$	30pF	1k Ω	open	GND	$2 \times V_{CC}$
2.3V to 2.7V	V_{CC}	$\leq 2.0ns$	30pF	500 Ω	open	GND	$2 \times V_{CC}$
2.7V	2.7V	$\leq 2.5ns$	50pF	500 Ω	open	GND	6V
3.0V to 3.6V	2.7V	$\leq 2.5ns$	50pF	500 Ω	open	GND	6V
4.5V to 5.5V	V_{CC}	$\leq 2.5ns$	50pF	500 Ω	open	GND	$2 \times V_{CC}$



5、 Package Information

5.1、 TSSOP8

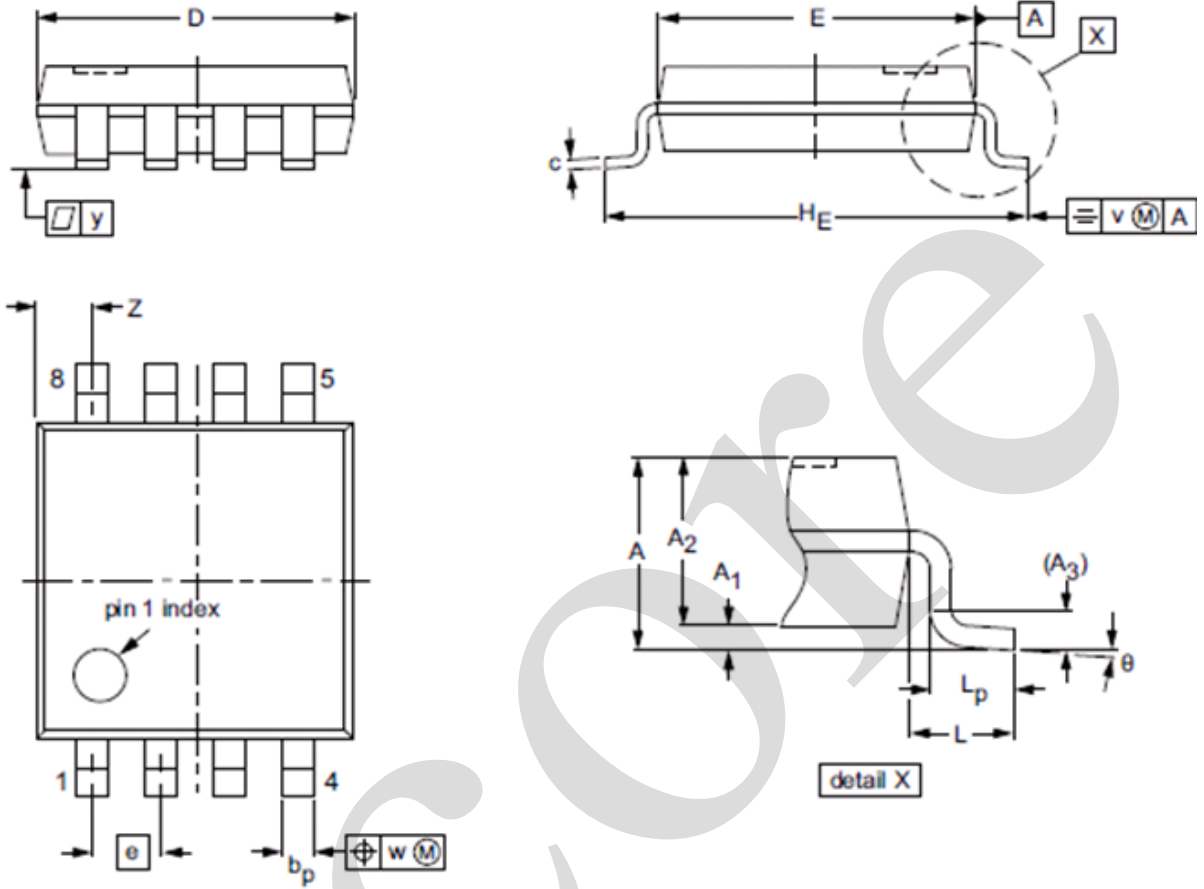

UNIT	A max.	A ₁	A ₂	A ₃	b _p	c	D ⁽¹⁾	E ⁽¹⁾	e	H _E	L	L _p	v	w	y	Z ⁽¹⁾	θ
mm	1.1	0.15 0.00	0.95 0.75	0.25	0.38 0.22	0.18 0.08	3.1 2.9	3.1 2.9	0.65	4.1 3.9	0.5	0.47 0.33	0.2	0.13	0.1	0.70 0.35	8° 0°



5.2. VSSOP8

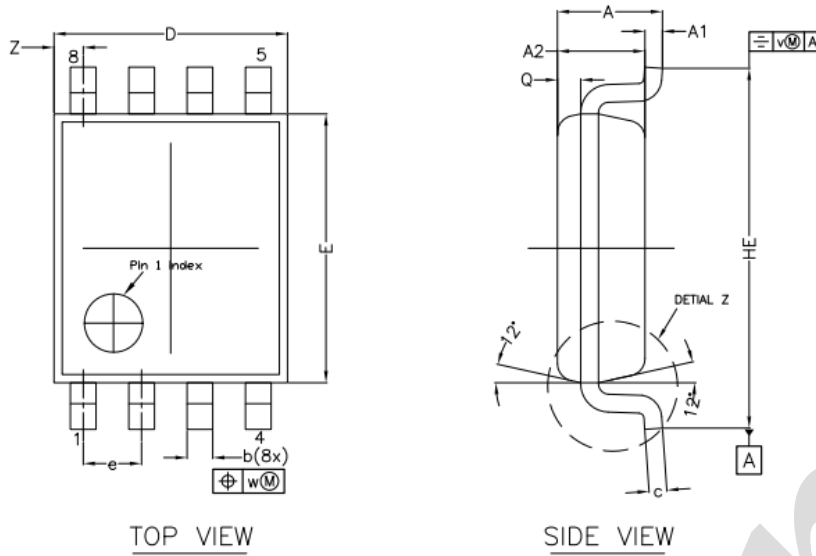

* CONTROLLING DIMENSION : MM

SYMBOL	MILLIMETER		
	MIN.	NOM.	MAX.
A	---	---	1.00
A1	0.00	---	0.15
A2	0.60	0.75	0.85
A3	---	0.12	---
Q	0.19	0.20	0.21
b	0.17	0.22	0.27
c	0.08	---	0.23
D	1.90	2.00	2.10
E	2.20	2.30	2.40
HE	3.00	3.10	3.20
e	0.50 bsc		
L	0.40 bsc		
L1	0.15	---	0.40
Y	---	0.10	---
v	---	0.20	---
w	---	0.08	---
Z	0.10	---	0.40
θ	0°	---	8°

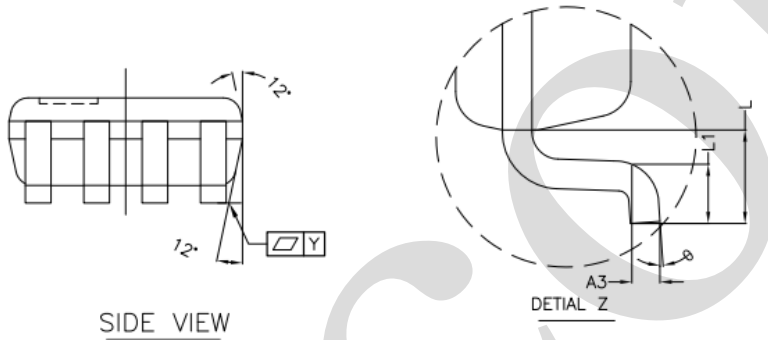

NOTES

1.0 COPLANARITY APPLIES TO LEADS, CORNER LEADS AND DIE ATTACH PAD.



6、 Statements And Notes

6.1、 The name and content of Hazardous substances or Elements in the product

Part name	Hazardous substances or Elements									
	Lead and lead compounds	Mercury and mercury compounds	Cadmium and cadmium compounds	Hexavalent chromium compounds	Polybrominated biphenyls	Polybrominated biphenyl ethers	Dibutyl phthalate	Butylbenzyl phthalate	Di-2-ethylhexyl phthalate	Diisobutyl phthalate
Lead frame	○	○	○	○	○	○	○	○	○	○
Plastic resin	○	○	○	○	○	○	○	○	○	○
Chip	○	○	○	○	○	○	○	○	○	○
The lead	○	○	○	○	○	○	○	○	○	○
Plastic sheet installed	○	○	○	○	○	○	○	○	○	○
explanation	○: Indicates that the content of hazardous substances or elements in the detection limit of the following the SJ/T11363-2006 standard. ×: Indicates that the content of hazardous substances or elements exceeding the SJ/T11363-2006 Standard limit requirements.									

6.2、 Notion

Recommended carefully reading this information before the use of this product;

The information in this document are subject to change without notice;

This information is using to the reference only, the company is not responsible for any loss;

The company is not responsible for the any infringement of the third party patents or other rights of the responsibility.

X-ON Electronics

Largest Supplier of Electrical and Electronic Components

Click to view similar products for [Flip-Flops](#) category:

Click to view products by [I-core](#) manufacturer:

Other Similar products are found below :

[NLV14027BDG](#) [703557B](#) [TC7W74FUTE12LF](#) [5962-9221804MRA](#) [NLV74HC74ADR2G](#) [74LVC74APW-Q100J](#) [74HC273M/TR](#)
[74HC32M/TR](#) [AIP74HC74SA.TR](#) [AIP74LVC2G14GC363.TR](#) [AIP74LVC2G74YA8.TR](#) [AIP74HC574TA.TR](#) [MC74HC73ADG](#)
[74LCX16374MTDX](#) [74LVT74D,118](#) [74VHCT9273FT\(BJ\)](#) [JM38510/37202BEA](#) [MM74HC374WM](#) [MM74HC74AMX](#)
[74ALVCH162374PAG](#) [74LVC1G175GS,132](#) [74LVX74MTCX](#) [TC7WZ74FK,LJ\(CT\)](#) [JM38510/30106BEA](#) [JM38510/00204BEA](#)
[CD54HC74F3A](#) [CD40174BF3A](#) [5962-8681501RA](#) [MM74HCT273WM](#) [SN74LVC74APW](#) [SN74LVC74AD](#) [MC74HC11ADG](#)
[M74HC377RM13TR](#) [M74HC374RM13TR](#) [M74HC175B1R](#) [M74HC174RM13TR](#) [74ALVTH16374ZQLR](#) [74ALVTH32374ZKER](#)
[74AUP1G74DC,125](#) [74VHC374FT\(BJ\)](#) [74VHCV374FT\(BJ\)](#) [74VHCV574FT\(BJ\)](#) [SN74LVC74ADR](#) [SN74HC574PWR](#) [SN74HC374AN](#)
[SN74AS574DWR](#) [SN74ALS175NSR](#) [SN74HC175D](#) [SN74AC74D](#) [74AHC1G79GV.125](#)