



AiP74LVC/LVCH2T45

2-bit Dual Supply Translating Transceiver; 3-State

Product Specification

Specification Revision History:

Version	Date	Description
2017-05-A1	2017-05	New
2021-04-A2	2021-04	Add TSSOP8 Package Form
2021-12-A3	2021-12	Modify ordering information; Modify ambient temperature to -40°C ~+105°C and add electrical characteristics of -40°C~+105°C
2022-03-A4	2022-03	Modify ordering information note 1



1、 General Description

The AiP74LVC2T45; AiP74LVCH2T45 are dual bit, dual supply translating transceivers with 3-state outputs that enable bidirectional level translation. They feature two 2-bits input-output ports(nA and nB), a direction control input (DIR) and dual supply pins ($V_{CC(A)}$ and $V_{CC(B)}$). Both $V_{CC(A)}$ and $V_{CC(B)}$ can be supplied at any voltage between 1.2V and 5.5V making the device suitable for translating between any of the low voltage nodes (1.2V, 1.5V, 1.8V, 2.5V, 3.3V and 5.0V). Pins nA and DIR are referenced to $V_{CC(A)}$ and pins nB are referenced to $V_{CC(B)}$. A HIGH on DIR allows transmission from nA to nB and a LOW on DIR allows transmission from nB to nA.

The devices are fully specified for partial power-down applications using I_{OFF} . The I_{OFF} circuitry disables the output, preventing any damaging backflow current through the device when it is powered down. In suspend mode when either $V_{CC(A)}$ or $V_{CC(B)}$ are at GND level, both A port and B port are in the high-impedance OFF-state.

Active bus hold circuitry in the AiP74LVCH2T45 holds unused or floating data inputs at a valid logic level.

Features:

- Wide supply voltage range:
 $V_{CC(A)}$: 1.2V to 5.5V
 $V_{CC(B)}$: 1.2V to 5.5V
- Maximum data rates:
420 Mbps (3.3V to 5.0V translation)
210 Mbps (translate to 3.3V)
140 Mbps (translate to 2.5V)
75 Mbps (translate to 1.8V)
60 Mbps (translate to 1.5V)
- Suspend mode
- $\pm 24\text{mA}$ output drive ($V_{CC}=3.0\text{V}$)
- Inputs accept voltages up to 5.5V
- Low power consumption: 16 μA maximum I_{CC}
- I_{OFF} circuitry provides partial Power-down mode operation
- Specified from -40°C to $+105^{\circ}\text{C}$
- Packaging information:VSSOP8/TSSOP8

**Ordering Information:****Tube packing specifications:**

Part number	Packaging form	Marking code	Tube quantity	Boxed tube quantity	Boxed quantity	Notes
AiP74LVC2T45TA8.TR	TSSOP8	CIXX	96 PCS/tube	140 tube/box	13440 PCS/box	Dimensions of plastic enclosure: 3.0mm×3.0mm Pin spacing: 0.65mm
AiP74LVCH2T45TA8.TR	TSSOP8	CRXX	96 PCS/tube	140 tube/box	13440 PCS/box	Dimensions of plastic enclosure: 3.0mm×3.0mm Pin spacing: 0.65mm

Reel packing specifications:

Part number	Packaging form	Marking code	Reel quantity	Boxed reel quantity	Notes
AiP74LVC2T45YA8.TR	VSSOP8	CIXX	3000 PCS/reel	3000 PCS/box	Dimensions of plastic enclosure: 2.0mm×2.3mm Pin spacing:0.50mm
AiP74LVC2T45TA8.TR	TSSOP8(1)	CIXX	3000 PCS/reel	6000 PCS/box	Dimensions of plastic enclosure: 3.0mm×3.0mm Pin spacing:0.65mm
AiP74LVC2T45TA8.TR	TSSOP8(2)	CIXX	3000 PCS/reel	3000 PCS/box	Dimensions of plastic enclosure: 3.0mm×3.0mm Pin spacing:0.65mm
AiP74LVCH2T45YA8.TR	VSSOP8	CRXX	3000 PCS/reel	3000 PCS/box	Dimensions of plastic enclosure: 2.0mm×2.3mm Pin spacing:0.50mm
AiP74LVCH2T45TA8.TR	TSSOP8(1)	CRXX	3000 PCS/reel	6000 PCS/box	Dimensions of plastic enclosure: 3.0mm×3.0mm Pin spacing:0.65mm
AiP74LVCH2T45TA8.TR	TSSOP8(2)	CRXX	3000 PCS/reel	3000 PCS/box	Dimensions of plastic enclosure: 3.0mm×3.0mm Pin spacing:0.65mm

Note 1: "XX" refers to variable content, meaning year and package batch serial number.

Note 2: If the physical information is inconsistent with the ordering information, please refer to the actual product.



2、Block Diagram And Pin Description

2.1、Block Diagram

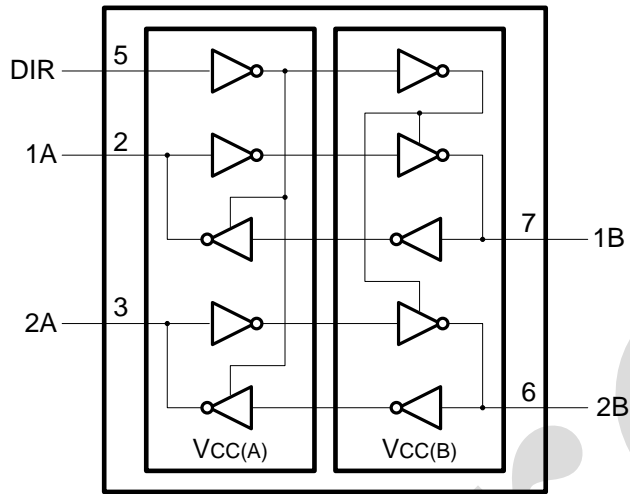

Figure 1. Logic symbol

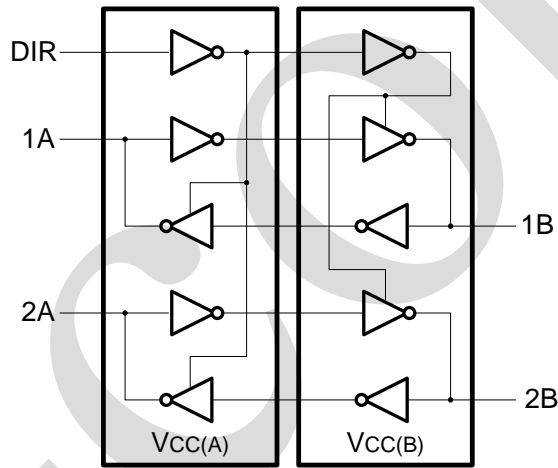
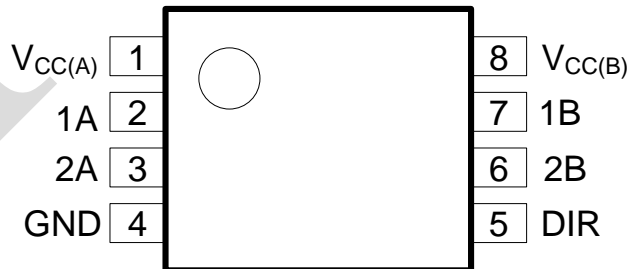

Figure 2. Logic diagram

2.2、Pin Configurations





2.3、Pin Description

Pin No.	Pin Name	Description
1	V _{CC(A)}	supply voltage A (port A and DIR)
2	1A	data input or output
3	2A	data input or output
4	GND	ground (0V)
5	DIR	direction control
6	2B	data input or output
7	1B	data input or output
8	V _{CC(B)}	supply voltage B (port B)

2.4、Function Table

H=HIGH voltage level; L=LOW voltage level; X=don't care; Z=high-impedance OFF-state.

Supply Voltage	Input	Input/output ^[1]	
		nA	nB
V _{CC(A)} , V _{CC(B)}	DIR	nA=nB	nB
1.2V to 5.5V	L	input	nB=nA
1.2V to 5.5V	H	input	nB=nA
GND ^[2]	X	Z	Z

Note:

[1] The input circuit of the data I/O is always active.

[2] When either V_{CC(A)} or V_{CC(B)} is at GND level, the device goes into suspend mode.

3、Electrical Parameter

3.1、Absolute Maximum Ratings

(Voltages are referenced to GND (ground=0V), unless otherwise specified)

Characteristic	Symbol	Conditions	Min.	Max.	Unit
supply voltage A	V _{CC(A)}	-	-0.5	+6.5	V
supply voltage B	V _{CC(B)}	-	-0.5	+6.5	V
input clamping current	V _{IK}	V _I <0V	-50	-	mA
input voltage	V _I	^[1]	-0.5	+6.5	V
output clamping current	I _{OK}	V _O <0V	-50	-	mA
output voltage	V _O	Active mode ^{[1][2][3]}	-0.5	V _{CCO} +0.5	V
		Suspend or 3-state mode ^[1]	-0.5	+6.5	V
output current	I _O	V _O =0V to V _{CCO} ^[2]	-	±50	mA
supply current	I _{CC}	I _{CC(A)} or I _{CC(B)}	-	100	mA
ground current	I _{GND}	-	-100	-	mA
storage temperature	T _{stg}	-	-65	+150	°C
total power dissipation	P _{tot}	T _{amb} =-40°C to +105°C ^[4]	-	250	mW
soldering temperature	T _L	10s	-	250	°C

Note:

[1] The minimum input voltage ratings and output voltage ratings may be exceeded if the input and output current ratings are observed.

[2] V_{CCO} is the supply voltage associated with the output port.

[3] V_{CCO}+0.5V should not exceed 6.5V.

[4] For VSSOP8 packages: above 110°C the value of P_{tot} derates linearly with 8.0mW/K.



3.2、Recommended Operating Conditions

Characteristic	Symbol	Conditions	Min.	Max.	Unit
supply voltage A	$V_{CC(A)}$	-	1.2	5.5	V
supply voltage B	$V_{CC(B)}$	-	1.2	5.5	V
input voltage	V_I	-	0	5.5	V
output voltage	V_O	Active mode ^[1]	0	V_{CCO}	V
		Suspend or 3-state mode	0	5.5	V
ambient temperature input transition rise and fall rate	T_{amb}	-	-40	+105	°C
	$\Delta t/\Delta V$	$V_{CCI}=1.2V^{[2]}$	-	20	ns/V
		$V_{CCI}=1.4V$ to $1.95V$	-	20	ns/V
		$V_{CCI}=2.3V$ to $2.7V$	-	20	ns/V
		$V_{CCI}=3V$ to $3.6V$	-	10	ns/V
		$V_{CCI}=4.5V$ to $5.5V$	-	5	ns/V

Note:

[1] V_{CCO} is the supply voltage associated with the output port.

[2] V_{CCI} is the supply voltage associated with the input port.

3.3、Electrical Characteristics

3.3.1、DC Characteristics 1

($T_{amb}=25^{\circ}C$, voltages are referenced to GND (ground=0V), unless otherwise specified)

Parameter	Symbol	Conditions	Min.	Typ.	Max.	Unit
HIGH-level output voltage	V_{OH}	$V_I=V_{IH}$ or V_{IL} ; $I_O=-3mA$; $V_{CCO}=1.2V^{[1]}$	-	1.09	-	V
LOW-level output voltage	V_{OL}	$V_I=V_{IH}$ or V_{IL} ; $I_O=3mA$; $V_{CCO}=1.2V^{[1]}$	-	0.07	-	V
input leakage current	I_I	DIR input; $V_I=0V$ to $5.5V$; $V_{CCI}=1.2V$ to $5.5V^{[2]}$	-	-	± 1	μA
bus hold LOW current	I_{BHL}	A or B port; $V_I=0.42V$; $V_{CCI}=1.2V^{[2]}$	-	19	-	μA
bus hold HIGH current	I_{BHH}	A or B port; $V_I=0.78V$; $V_{CCI}=1.2V^{[2]}$	-	-19	-	μA
bus hold LOW overdrive current	I_{BHLO}	A or B port; $V_{CCI}=1.2V^{[2][3]}$	-	19	-	μA
bus hold HIGH overdrive current	I_{BHHO}	A or B port; $V_{CCI}=1.2V^{[2][3]}$	-	-19	-	μA
OFF-state output current	I_{OZ}	A or B port; $V_O=0V$ or V_{CCO} ; $V_{CCO}=1.2V$ to $5.5V^{[1]}$	-	-	± 1	μA
power-off leakage current	I_{OFF}	A port; V_I or $V_O=0V$ to $5.5V$; $V_{CC(A)}=0V$; $V_{CC(B)}=1.2V$ to $5.5V$	-	-	± 1	μA
		B port; V_I or $V_O=0V$ to $5.5V$; $V_{CC(B)}=0V$; $V_{CC(A)}=1.2V$ to $5.5V$	-	-	± 1	μA
input capacitance	C_I	DIR input; $V_I=0V$ or $3.3V$; $V_{CC(A)}=V_{CC(B)}=3.3V$	-	2.2	-	pF
input/output capacitance	$C_{I/O}$	A and B port; suspend mode; $V_O=3.3V$ or $0V$; $V_{CC(A)}=V_{CC(B)}=3.3V$	-	6.0	-	pF



Note:

[1] V_{CCO} is the supply voltage associated with the output port.

[2] V_{CCI} is the supply voltage associated with the data input port.

[3] To guarantee the node switches, an external driver must source/sink at least I_{BHLO}/I_{BHHO} when the input is in the range V_{IL} to V_{IH} .

3.3.2、DC Characteristics 2

($T_{amb}=-40^{\circ}\text{C}$ to $+85^{\circ}\text{C}$, voltages are referenced to GND (ground=0V), unless otherwise specified)

Parameter	Symbol	Conditions	Min.	Typ.	Max.	Unit	
HIGH-level input voltage	V_{IH}	data input ^[1]	$V_{CCI}=1.2\text{V}$	$0.8V_{CCI}$	-	-	V
			$V_{CCI}=1.4\text{V}$ to 1.95V	$0.65V_{CCI}$	-	-	V
			$V_{CCI}=2.3\text{V}$ to 2.7V	1.7	-	-	V
			$V_{CCI}=3.0\text{V}$ to 3.6V	2.0	-	-	V
			$V_{CCI}=4.5\text{V}$ to 5.5V	$0.7V_{CCI}$	-	-	V
		DIR input	$V_{CCI}=1.2\text{V}$	$0.8V_{CC(A)}$	-	-	V
			$V_{CCI}=1.4\text{V}$ to 1.95V	$0.65V_{CC(A)}$	-	-	V
			$V_{CCI}=2.3\text{V}$ to 2.7V	1.7	-	-	V
			$V_{CCI}=3.0\text{V}$ to 3.6V	2.0	-	-	V
			$V_{CCI}=4.5\text{V}$ to 5.5V	$0.7V_{CC(A)}$	-	-	V
LOW-level input voltage	V_{IL}	data input ^[1]	$V_{CCI}=1.2\text{V}$	-	-	$0.2V_{CCI}$	V
			$V_{CCI}=1.4\text{V}$ to 1.95V	-	-	$0.35V_{CCI}$	V
			$V_{CCI}=2.3\text{V}$ to 2.7V	-	-	0.7	V
			$V_{CCI}=3.0\text{V}$ to 3.6V	-	-	0.8	V
			$V_{CCI}=4.5\text{V}$ to 5.5V	-	-	$0.3V_{CCI}$	V
		DIR input	$V_{CCI}=1.2\text{V}$	-	-	$0.2V_{CC(A)}$	V
			$V_{CCI}=1.4\text{V}$ to 1.95V	-	-	$0.35V_{CC(A)}$	V
			$V_{CCI}=2.3\text{V}$ to 2.7V	-	-	0.7	V
			$V_{CCI}=3.0\text{V}$ to 3.6V	-	-	0.8	V
			$V_{CCI}=4.5\text{V}$ to 5.5V	-	-	$0.3V_{CC(A)}$	V
HIGH-level output voltage	V_{OH}	$V_I=V_{IH}$	$I_O=-100\mu\text{A}; V_{CCO}=1.2\text{V}$ to $4.5\text{V}^{[2]}$	$V_{CCO}-0.1$	-	-	V
			$I_O=-6\text{mA}; V_{CCO}=1.4\text{V}$	1.0	-	-	V
			$I_O=-8\text{mA}; V_{CCO}=1.65\text{V}$	1.2	-	-	V
			$I_O=-12\text{mA}; V_{CCO}=2.3\text{V}$	1.9	-	-	V
			$I_O=-24\text{mA}; V_{CCO}=3.0\text{V}$	2.4	-	-	V
			$I_O=-32\text{mA}; V_{CCO}=4.5\text{V}$	3.8	-	-	V
LOW-level output voltage	V_{OL}	$V_I=V_{IH}^{[2]}$	$I_O=100\mu\text{A}; V_{CCO}=1.2\text{V}$ to 4.5V	-	-	0.1	V
			$I_O=6\text{mA}; V_{CCO}=1.4\text{V}$	-	-	0.3	V
			$I_O=8\text{mA}; V_{CCO}=1.65\text{V}$	-	-	0.45	V
			$I_O=12\text{mA}; V_{CCO}=2.3\text{V}$	-	-	0.3	V
			$I_O=24\text{mA}; V_{CCO}=3.0\text{V}$	-	-	0.55	V
$I_O=32\text{mA}; V_{CCO}=4.5\text{V}$	-	-	0.55	V			
input leakage current	I_I	DIR input; $V_I=0\text{V}$ to $5.5\text{V}; V_{CCI}=1.2\text{V}$ to 5.5V	-	-	± 2	μA	



Wuxi I-CORE Electronics Co., Ltd.

Tab: 835-12

rev:B3

Number: AiP74LVC/LVCH2T45-AX-LJ-B082EN

bus hold LOW current	I_{BHL}	A or B port ^[1]	$V_I=0.49V; V_{CCI}=1.4V$	15	-	-	uA
			$V_I=0.58V; V_{CCI}=1.65V$	25	-	-	uA
			$V_I=0.70V; V_{CCI}=2.3V$	45	-	-	uA
			$V_I=0.80V; V_{CCI}=3.0V$	100	-	-	uA
			$V_I=1.35V; V_{CCI}=4.5V$	100	-	-	uA
bus hold HIGH current	I_{BHH}	A or B port ^[1]	$V_I=0.91V; V_{CCI}=1.4V$	-15	-	-	uA
			$V_I=1.07V; V_{CCI}=1.65V$	-25	-	-	uA
			$V_I=1.60V; V_{CCI}=2.3V$	-45	-	-	uA
			$V_I=2.00V; V_{CCI}=3.0V$	-100	-	-	uA
			$V_I=3.15V; V_{CCI}=4.5V$	-100	-	-	uA
bus hold LOW overdrive current	I_{BHLO}	A or B port ^{[1][3]}	$V_{CCI}=1.6V$	125	-	-	uA
			$V_{CCI}=1.95V$	200	-	-	uA
			$V_{CCI}=2.7V$	300	-	-	uA
			$V_{CCI}=3.6V$	500	-	-	uA
			$V_{CCI}=5.5V$	900	-	-	uA
bus hold HIGH overdrive current	I_{BHHO}	A or B port ^{[1][3]}	$V_{CCI}=1.6V$	-125	-	-	uA
			$V_{CCI}=1.95V$	-200	-	-	uA
			$V_{CCI}=2.7V$	-300	-	-	uA
			$V_{CCI}=3.6V$	-500	-	-	uA
			$V_{CCI}=5.5V$	-900	-	-	uA
OFF-state output	I_{OZ}	A or B port; $V_O=0V$ or V_{CCO} ; $V_{CCO}=1.2V$ to $5.5V$ ^[2]		-	-	± 2	uA
power-off leakage current	I_{OFF}	A port; V_I or $V_O=0V$ to $5.5V$; $V_{CC(A)}=0V$; $V_{CC(B)}=1.2V$ to $5.5V$		-	-	± 2	uA
		B port; V_I or $V_O=0V$ to $5.5V$; $V_{CC(B)}=0V$; $V_{CC(A)}=1.2V$ to $5.5V$		-	-	± 2	uA
supply current	I_{CC}	A port; $V_I=0V$ or V_{CCI} ; $I_O=0A$ ^[1]	$V_{CC(A)}, V_{CC(B)}=1.2V$ to $5.5V$	-	-	8	uA
			$V_{CC(A)}, V_{CC(B)}=1.65V$ to $5.5V$	-	-	3	uA
			$V_{CC(A)}=5.5V$; $V_{CC(B)}=0V$	-	-	2	uA
			$V_{CC(A)}=0V$; $V_{CC(B)}=5.5V$	-2	-	-	uA
		B port; $V_I=0V$ or V_{CCI} ; $I_O=0A$	$V_{CC(A)}, V_{CC(B)}=1.2V$ to $5.5V$	-	-	8	uA
			$V_{CC(A)}, V_{CC(B)}=1.65V$ to $5.5V$	-	-	3	uA
			$V_{CC(B)}=0V$; $V_{CC(A)}=5.5V$	-2	-	-	uA
			$V_{CC(B)}=5.5V$; $V_{CC(A)}=0V$	-	-	2	uA
		A plus B port ($I_{CC(A)}+I_{CC(B)}$); $I_O=0A$; $V_I=0V$ or V_{CCI}	$V_{CC(A)}, V_{CC(B)}=1.2V$ to $5.5V$	-	-	16	uA
			$V_{CC(A)}, V_{CC(B)}=1.65V$ to $5.5V$	-	-	4	uA
additional supply current	ΔI_{CC}	per input; $V_{CC(A)}, V_{CC(B)}=$ $3.0V$ to $5.5V$	A port; A port at $V_{CC(A)}-0.6V$; DIR at $V_{CC(A)}$; B port=open ^[4]	-	-	50	uA
			DIR input; DIR at $V_{CC(A)}-0.6V$; A port at $V_{CC(A)}$ or GND; B port=open	-	-	50	uA
			B port; B port at $V_{CC(B)}-0.6V$; DIR at GND; A port=open ^[4]	-	-	50	uA



Note:

- [1] V_{CCI} is the supply voltage associated with the data input port.
- [2] V_{CCO} is the supply voltage associated with the output port.
- [3] To guarantee the node switches, an external driver must source/sink at least I_{BHLO}/I_{BHHO} when the input is in the range V_{IL} to V_{IH} .
- [4] For non bus hold parts only (AiP74LVC2T45).

3.3.3、DC Characteristics 3

($T_{amb}=-40^{\circ}\text{C}$ to $+105^{\circ}\text{C}$, voltages are referenced to GND (ground=0V), unless otherwise specified)

Parameter	Symbol	Conditions	Min.	Typ.	Max.	Unit	
HIGH-level input voltage	V_{IH}	data input ^[1]	$V_{CCI}=1.2\text{V}$	$0.8V_{CCI}$	-	-	V
			$V_{CCI}=1.4\text{V}$ to 1.95V	$0.65V_{CCI}$	-	-	V
			$V_{CCI}=2.3\text{V}$ to 2.7V	1.7	-	-	V
			$V_{CCI}=3.0\text{V}$ to 3.6V	2.0	-	-	V
			$V_{CCI}=4.5\text{V}$ to 5.5V	$0.7V_{CCI}$	-	-	V
		DIR input	$V_{CCI}=1.2\text{V}$	$0.8V_{CC(A)}$	-	-	V
			$V_{CCI}=1.4\text{V}$ to 1.95V	$0.65V_{CC(A)}$	-	-	V
			$V_{CCI}=2.3\text{V}$ to 2.7V	1.7	-	-	V
			$V_{CCI}=3.0\text{V}$ to 3.6V	2.0	-	-	V
			$V_{CCI}=4.5\text{V}$ to 5.5V	$0.7V_{CC(A)}$	-	-	V
LOW-level input voltage	V_{IL}	data input ^[1]	$V_{CCI}=1.2\text{V}$	-	-	$0.2V_{CCI}$	V
			$V_{CCI}=1.4\text{V}$ to 1.95V	-	-	$0.35V_{CCI}$	V
			$V_{CCI}=2.3\text{V}$ to 2.7V	-	-	0.7	V
			$V_{CCI}=3.0\text{V}$ to 3.6V	-	-	0.8	V
			$V_{CCI}=4.5\text{V}$ to 5.5V	-	-	$0.3V_{CCI}$	V
		DIR input	$V_{CCI}=1.2\text{V}$	-	-	$0.2V_{CC(A)}$	V
			$V_{CCI}=1.4\text{V}$ to 1.95V	-	-	$0.35V_{CC(A)}$	V
			$V_{CCI}=2.3\text{V}$ to 2.7V	-	-	0.7	V
			$V_{CCI}=3.0\text{V}$ to 3.6V	-	-	0.8	V
			$V_{CCI}=4.5\text{V}$ to 5.5V	-	-	$0.3V_{CC(A)}$	V
HIGH-level output voltage	V_{OH}	$V_I=V_{IH}$	$I_O=-100\mu\text{A}; V_{CCO}=1.2\text{V}$ to $4.5\text{V}^{[2]}$	$V_{CCO}-0.1$	-	-	V
			$I_O=-6\text{mA}; V_{CCO}=1.4\text{V}$	1.0	-	-	V
			$I_O=-8\text{mA}; V_{CCO}=1.65\text{V}$	1.2	-	-	V
			$I_O=-12\text{mA}; V_{CCO}=2.3\text{V}$	1.9	-	-	V
			$I_O=-24\text{mA}; V_{CCO}=3.0\text{V}$	2.4	-	-	V
			$I_O=-32\text{mA}; V_{CCO}=4.5\text{V}$	3.8	-	-	V
LOW-level output voltage	V_{OL}	$V_I=V_{IH}^{[2]}$	$I_O=100\mu\text{A}; V_{CCO}=1.2\text{V}$ to 4.5V	-	-	0.1	V
			$I_O=6\text{mA}; V_{CCO}=1.4\text{V}$	-	-	0.3	V
			$I_O=8\text{mA}; V_{CCO}=1.65\text{V}$	-	-	0.45	V
			$I_O=12\text{mA}; V_{CCO}=2.3\text{V}$	-	-	0.3	V
			$I_O=24\text{mA}; V_{CCO}=3.0\text{V}$	-	-	0.55	V
			$I_O=32\text{mA}; V_{CCO}=4.5\text{V}$	-	-	0.55	V



Wuxi I-CORE Electronics Co., Ltd.

Tab: 835-12

rev:B3

Number: AiP74LVCLVCH2T45-AX-LJ-B082EN

input leakage current	I_I	DIR input; $V_I=0V$ to 5.5V; $V_{CCI}=1.2V$ to 5.5V		-	-	± 10	μA
bus hold LOW current	I_{BHL}	A or B port ^[1]	$V_I=0.49V$; $V_{CCI}=1.4V$	10	-	-	μA
			$V_I=0.58V$; $V_{CCI}=1.65V$	20	-	-	μA
			$V_I=0.70V$; $V_{CCI}=2.3V$	45	-	-	μA
			$V_I=0.80V$; $V_{CCI}=3.0V$	80	-	-	μA
			$V_I=1.35V$; $V_{CCI}=4.5V$	100	-	-	μA
bus hold HIGH current	I_{BHH}	A or B port ^[1]	$V_I=0.91V$; $V_{CCI}=1.4V$	-10	-	-	μA
			$V_I=1.07V$; $V_{CCI}=1.65V$	-20	-	-	μA
			$V_I=1.60V$; $V_{CCI}=2.3V$	-45	-	-	μA
			$V_I=2.00V$; $V_{CCI}=3.0V$	-80	-	-	μA
			$V_I=3.15V$; $V_{CCI}=4.5V$	-100	-	-	μA
bus hold LOW overdrive current	I_{BHLO}	A or B port ^{[1][3]}	$V_{CCI}=1.6V$	125	-	-	μA
			$V_{CCI}=1.95V$	200	-	-	μA
			$V_{CCI}=2.7V$	300	-	-	μA
			$V_{CCI}=3.6V$	500	-	-	μA
			$V_{CCI}=5.5V$	900	-	-	μA
bus hold HIGH overdrive current	I_{BHHO}	A or B port ^{[1][3]}	$V_{CCI}=1.6V$	-125	-	-	μA
			$V_{CCI}=1.95V$	-200	-	-	μA
			$V_{CCI}=2.7V$	-300	-	-	μA
			$V_{CCI}=3.6V$	-500	-	-	μA
			$V_{CCI}=5.5V$	-900	-	-	μA
OFF-state output	I_{OZ}	A or B port; $V_O=0V$ or V_{CCO} ; $V_{CCO}=1.2V$ to 5.5V ^[2]		-	-	± 10	μA
power-off leakage current	I_{OFF}	A port; V_I or $V_O=0V$ to 5.5V; $V_{CC(A)}=0V$; $V_{CC(B)}=1.2V$ to 5.5V		-	-	± 10	μA
		B port; V_I or $V_O=0V$ to 5.5V; $V_{CC(B)}=0V$; $V_{CC(A)}=1.2V$ to 5.5V		-	-	± 10	μA
supply current	I_{CC}	A port; $V_I=0V$ or V_{CCI} ; $I_O=0A$ ^[1]	$V_{CC(A)}, V_{CC(B)}=1.2V$ to 5.5V	-	-	8	μA
			$V_{CC(A)}, V_{CC(B)}=1.65V$ to 5.5V	-	-	3	μA
			$V_{CC(A)}=5.5V$; $V_{CC(B)}=0V$	-	-	2	μA
			$V_{CC(A)}=0V$; $V_{CC(B)}=5.5V$	-2	-	-	μA
		B port; $V_I=0V$ or V_{CCI} ; $I_O=0A$	$V_{CC(A)}, V_{CC(B)}=1.2V$ to 5.5V	-	-	8	μA
			$V_{CC(A)}, V_{CC(B)}=1.65V$ to 5.5V	-	-	3	μA
			$V_{CC(B)}=0V$; $V_{CC(A)}=5.5V$	-2	-	-	μA
			$V_{CC(B)}=5.5V$; $V_{CC(A)}=0V$	-	-	2	μA
		A plus B port ($I_{CC(A)}+I_{CC(B)}$); $I_O=0A$; $V_I=0V$ or V_{CCI}	$V_{CC(A)}, V_{CC(B)}=1.2V$ to 5.5V	-	-	16	μA
			$V_{CC(A)}, V_{CC(B)}=1.65V$ to 5.5V	-	-	4	μA
additional supply current	ΔI_{CC}	per input; $V_{CC(A)}, V_{CC(B)}=3.0V$ to 5.5V	A port; A port at $V_{CC(A)}-0.6V$; DIR at $V_{CC(A)}$; B port=open ^[4]	-	-	75	μA
			DIR input; DIR at $V_{CC(A)}-0.6V$; A port at $V_{CC(A)}$ or GND; B port=open	-	-	75	μA



			B port; B port at $V_{CC(B)}-0.6V$; DIR at GND; A port=open ^[4]	-	-	75	uA
--	--	--	--	---	---	----	----

Note:

[1] V_{CCI} is the supply voltage associated with the data input port.

[2] V_{CCO} is the supply voltage associated with the output port.

[3] To guarantee the node switches, an external driver must source/sink at least I_{BHLO}/I_{BHHO} when the input is in the range V_{IL} to V_{IH} .

[4] For non bus hold parts only (AiP74LVC2T45).

3.3.4、AC Characteristics 1

($T_{amb}=25^{\circ}C$, $V_{CC(A)}=1.2V$, voltages are referenced to GND (ground=0V), unless otherwise specified)

Parameter	Symbol	Conditions	$V_{CC(B)}$						Unit
			1.2V	1.5V	1.8V	2.5V	3.3V	5.0V	
LOW to HIGH propagation delay	t_{PLH}	A to B	10.6	8.1	7.0	5.8	5.3	5.1	ns
		B to A	10.6	9.5	9.0	8.5	8.3	8.2	ns
HIGH to LOW propagation delay	t_{PHL}	A to B	10.1	7.1	6.0	5.3	5.2	5.4	ns
		B to A	10.1	8.6	8.1	7.8	7.6	7.6	ns
HIGH to OFF-state propagation delay	t_{PHZ}	DIR to A	9.4	9.4	9.4	9.4	9.4	9.4	ns
		DIR to B	12.0	9.4	9.0	7.8	8.4	7.9	ns
LOW to OFF-state propagation delay	t_{PLZ}	DIR to A	7.1	7.1	7.1	7.1	7.1	7.1	ns
		DIR to B	9.5	7.8	7.7	6.9	7.6	7.0	ns
OFF-state to HIGH propagation delay	t_{PZH}	DIR to A ^[1]	20.1	17.3	16.7	15.4	15.9	15.2	ns
		DIR to B ^[1]	17.7	15.2	14.1	12.9	12.4	12.2	ns
OFF-state to LOW propagation delay	t_{PZL}	DIR to A ^[1]	22.1	18.0	17.1	15.6	16.0	15.5	ns
		DIR to B ^[1]	19.5	16.5	15.4	14.7	14.6	14.8	ns

Note:

[1] t_{PZH} and t_{PZL} are calculated values using the formula shown in Section 6.4.

3.3.5、AC Characteristics 2

($T_{amb}=25^{\circ}C$, $V_{CC(B)}=1.2V$, voltages are referenced to GND (ground=0V), unless otherwise specified)

Parameter	Symbol	Conditions	$V_{CC(A)}$						Unit
			1.2V	1.5V	1.8V	2.5V	3.3V	5.0V	
LOW to HIGH propagation delay	t_{PLH}	A to B	10.6	9.5	9.0	8.5	8.3	8.2	ns
		B to A	10.6	8.1	7.0	5.8	5.3	5.1	ns
HIGH to LOW propagation delay	t_{PHL}	A to B	10.1	8.6	8.1	7.8	7.6	7.6	ns
		B to A	10.1	7.1	6.0	5.3	5.2	5.4	ns
HIGH to OFF-state propagation delay	t_{PHZ}	DIR to A	9.4	6.5	5.7	4.1	4.1	3.0	ns
		DIR to B	12.0	6.1	5.4	4.6	4.3	4.0	ns
LOW to OFF-state propagation delay	t_{PLZ}	DIR to A	7.1	4.9	4.5	3.2	3.4	2.5	ns
		DIR to B	9.5	7.3	6.6	5.9	5.7	5.6	ns
OFF-state to HIGH propagation delay	t_{PZH}	DIR to A ^[1]	20.1	15.4	13.6	11.7	11.0	10.7	ns
		DIR to B ^[1]	17.7	14.4	13.5	11.7	11.7	10.7	ns
OFF-state to LOW propagation delay	t_{PZL}	DIR to A ^[1]	22.1	13.2	11.4	9.9	9.5	9.4	ns
		DIR to B ^[1]	19.5	15.1	13.8	11.9	11.7	10.6	ns



Note:

[1] t_{PZH} and t_{PZL} are calculated values using the formula shown in Section 6.4.

3.3.6、AC Characteristics 3

(T_{amb}=25°C, V_{CC(A)}= V_{CC(B)}, voltages are referenced to GND (ground=0V), unless otherwise specified)

Parameter	Symbol	Conditions	V _{CC(A)} and V _{CC(B)}				Unit
			1.8V	2.5V	3.3V	5.0V	
power dissipation capacitance ^{[1][2]}	C _{PD}	A port: (direction A to B); B port: (direction B to A)	2	3	3	4	pF
		A port: (direction A to B); B port: (direction B to A)	15	16	16	18	pF

Note:

[1] C_{PD} is used to determine the dynamic power dissipation (P_D in uW). $P_D = C_{PD} \times V_{CC}^2 \times f_i \times N + \Sigma(C_L \times V_{CC}^2 \times f_o)$ where:f_i=input frequency in MHz;f_o=output frequency in MHz;C_L=load capacitance in pF;V_{CC}=supply voltage in V;

N=number of inputs switching;

 $\Sigma(C_L \times V_{CC}^2 \times f_o)$ =sum of the outputs.[2] f_i=10MHz; V_I=GND to V_{CC}; t_r=t_f=1ns; C_L=0pF; R_L=∞Ω.

3.3.7、AC Characteristics 4

(T_{amb}=-40°C to +85°C, voltages are referenced to GND (ground=0V), unless otherwise specified)

Parameter	Symbol	Conditions	V _{CC(B)}										Unit
			1.5V±0.1V		1.8V±0.15V		2.5V±0.2V		3.3V±0.3V		5.0V±0.5V		
			Min.	Max.	Min.	Max.	Min.	Max.	Min.	Max.	Min.	Max.	
V _{CC(A)} =1.4V to 1.6V													
LOW to HIGH propagation delay	t _{PLH}	A to B	2.8	21.3	2.4	17.6	2.0	13.5	1.7	11.8	1.6	10.5	ns
		B to A	2.8	21.3	2.6	19.1	2.3	14.9	2.3	12.4	2.2	12.0	ns
HIGH to LOW propagation delay	t _{PHL}	A to B	2.6	19.3	2.2	15.3	1.8	11.8	1.7	10.9	1.7	10.8	ns
		B to A	2.6	19.3	2.4	17.3	2.3	13.2	2.2	11.3	2.3	11.0	ns
HIGH to OFF-state propagation delay	t _{PHZ}	DIR to A	3.0	18.7	3.0	18.7	3.0	18.7	3.0	18.7	3.0	18.7	ns
		DIR to B	3.5	24.8	3.5	23.6	3.0	11.0	3.3	11.3	2.8	10.3	ns
LOW to OFF-state propagation delay	t _{PLZ}	DIR to A	2.4	11.4	2.4	11.4	2.4	11.4	2.4	11.4	2.4	11.4	ns
		DIR to B	2.8	18.3	3.0	17.2	2.5	9.4	3.0	10.1	2.5	9.4	ns
OFF-state to HIGH propagation delay	t _{PZH}	DIR to A ^[1]	-	39.6	-	36.3	-	24.3	-	22.5	-	21.4	ns
		DIR to B ^[1]	-	32.7	-	29.0	-	24.9	-	23.2	-	21.9	ns



Wuxi I-CORE Electronics Co., Ltd.

Tab: 835-12

rev:B3

Number: AiP74LVC/LVCH2T45-AX-LJ-B082EN

OFF-state to LOW propagation delay	t_{PZL}	DIR to A ^[1]	-	44.1	-	40.9	-	24.2	-	22.6	-	21.3	ns
		DIR to B ^[1]	-	38.0	-	34.0	-	30.5	-	29.6	-	29.5	ns
$V_{CC(A)}=1.65V$ to $1.95V$													
LOW to HIGH propagation delay	t_{PLH}	A to B	2.6	19.1	2.2	17.7	2.2	9.3	1.7	7.2	1.4	6.8	ns
		B to A	2.4	17.6	2.2	17.7	2.3	16.0	2.1	15.5	1.9	15.1	ns
HIGH to LOW propagation delay	t_{PHL}	A to B	2.4	17.3	2.0	14.3	1.6	8.5	1.8	7.1	1.7	7.0	ns
		B to A	2.2	15.3	2.0	14.3	2.1	12.9	2.0	12.6	1.8	12.2	ns
HIGH to OFF-state propagation delay	t_{PHZ}	DIR to A	2.9	17.1	2.9	17.1	2.9	17.1	2.9	17.1	2.9	17.1	ns
		DIR to B	3.2	24.1	3.2	21.9	2.7	11.5	3.0	10.3	2.5	8.2	ns
LOW to OFF-state propagation delay	t_{PLZ}	DIR to A	2.4	10.5	2.4	10.5	2.4	10.5	2.4	10.5	2.4	10.5	ns
		DIR to B	2.5	17.6	2.6	16.0	2.2	9.2	2.7	8.4	2.4	7.1	ns
OFF-state to HIGH propagation delay	t_{PZH}	DIR to A ^[1]	-	35.2	-	33.7	-	25.2	-	23.9	-	22.2	ns
		DIR to B ^[1]	-	29.6	-	28.2	-	19.8	-	17.7	-	17.3	ns
OFF-state to LOW propagation delay	t_{PZL}	DIR to A ^[1]	-	39.4	-	36.2	-	24.4	-	22.9	-	20.4	ns
		DIR to B ^[1]	-	34.4	-	31.4	-	25.6	-	24.2	-	24.1	ns
$V_{CC(A)}=2.3V$ to $2.7V$													
LOW to HIGH propagation delay	t_{PLH}	A to B	2.3	17.9	2.3	16.0	1.5	8.5	1.3	6.2	1.1	4.8	ns
		B to A	2.0	13.5	2.2	9.3	1.5	8.5	1.4	8.0	1.0	7.5	ns
HIGH to LOW propagation delay	t_{PHL}	A to B	2.3	15.8	2.1	12.9	1.4	7.5	1.3	5.4	0.9	4.6	ns
		B to A	1.8	11.8	1.9	8.5	1.4	7.5	1.3	7.0	0.9	6.2	ns
HIGH to OFF-state propagation delay	t_{PHZ}	DIR to A	2.1	8.1	2.1	8.1	2.1	8.1	2.1	8.1	2.1	8.1	ns
		DIR to B	3.0	22.5	3.0	21.4	2.5	11.0	2.8	9.3	2.3	6.9	ns
LOW to OFF-state propagation delay	t_{PLZ}	DIR to A	1.7	5.8	1.7	5.8	1.7	5.8	1.7	5.8	1.7	5.8	ns
		DIR to B	2.3	14.6	2.5	13.2	2.0	9.0	2.5	8.4	1.8	5.8	ns
OFF-state to HIGH propagation delay	t_{PZH}	DIR to A ^[1]	-	28.1	-	22.5	-	17.5	-	16.4	-	13.3	ns
		DIR to B ^[1]	-	23.7	-	21.8	-	14.3	-	12.0	-	10.6	ns
OFF-state to LOW propagation delay	t_{PZL}	DIR to A ^[1]	-	34.3	-	29.9	-	18.5	-	16.3	-	13.1	ns
		DIR to B ^[1]	-	23.9	-	21.0	-	15.6	-	13.5	-	12.7	ns



Wuxi I-CORE Electronics Co., Ltd.

Tab: 835-12

rev:B3

Number: AiP74LVC/LVCH2T45-AX-LJ-B082EN

V _{CC(A)} =3.0V to 3.6V													
LOW to HIGH propagation delay	t _{PLH}	A to B	2.3	17.1	2.1	15.5	1.4	8.0	0.8	5.6	0.7	4.4	ns
		B to A	1.7	11.8	1.7	7.2	1.3	6.2	0.7	5.6	0.6	5.4	ns
HIGH to LOW propagation delay	t _{PHL}	A to B	2.2	15.6	2.0	12.6	1.3	7.0	0.8	5.0	0.7	4.0	ns
		B to A	1.7	10.9	1.8	7.1	1.3	5.4	0.8	5.0	0.7	4.5	ns
HIGH to OFF-state propagation delay	t _{PHZ}	DIR to A	2.3	7.3	2.3	7.3	2.3	7.3	2.3	7.3	2.7	7.3	ns
		DIR to B	2.9	18.0	2.9	16.5	2.3	10.1	2.7	8.6	2.2	6.3	ns
LOW to OFF-state propagation delay	t _{PLZ}	DIR to A	2.0	5.6	2.0	5.6	2.0	5.6	2.0	5.6	2.0	5.6	ns
		DIR to B	2.3	13.6	2.4	12.5	1.9	7.8	2.3	7.1	1.7	4.9	ns
OFF-state to HIGH propagation delay	t _{PZH}	DIR to A ^[1]	-	25.4	-	19.7	-	14.0	-	12.7	-	10.3	ns
		DIR to B ^[1]	-	22.7	-	21.1	-	13.6	-	11.2	-	10.0	ns
OFF-state to LOW propagation delay	t _{PZL}	DIR to A ^[1]	-	28.9	-	23.6	-	15.5	-	13.6	-	10.8	ns
		DIR to B ^[1]	-	22.9	-	19.9	-	14.3	-	12.3	-	11.3	ns
V _{CC(A)} =4.5V to 5.5V													
LOW to HIGH propagation delay	t _{PLH}	A to B	2.2	16.6	1.9	15.1	1.0	7.5	0.7	5.4	0.5	3.9	ns
		B to A	1.6	10.5	1.4	6.8	1.0	4.8	0.7	4.4	0.5	3.9	ns
HIGH to LOW propagation delay	t _{PHL}	A to B	2.3	15.3	1.8	12.2	1.0	6.2	0.7	4.5	0.5	3.5	ns
		B to A	1.7	10.8	1.7	7.0	0.9	4.6	0.7	4.0	0.5	3.5	ns
HIGH to OFF-state propagation delay	t _{PHZ}	DIR to A	1.7	5.4	1.7	5.4	1.7	5.4	1.7	5.4	1.7	5.4	ns
		DIR to B	2.9	17.3	2.9	16.1	2.3	9.7	2.7	8.0	2.5	5.7	ns
LOW to OFF-state propagation delay	t _{PLZ}	DIR to A	1.4	3.7	1.4	3.7	1.3	3.7	1.0	3.7	0.9	3.7	ns
		DIR to B	2.3	13.1	2.4	12.1	1.9	7.4	2.3	7.0	1.8	4.5	ns
OFF-state to HIGH propagation delay	t _{PZH}	DIR to A ^[1]	-	23.6	-	18.9	-	12.2	-	11.4	-	8.4	ns
		DIR to B ^[1]	-	20.3	-	18.8	-	11.2	-	9.1	-	7.6	ns
OFF-state to LOW propagation delay	t _{PZL}	DIR to A ^[1]	-	28.1	-	23.1	-	14.3	-	12.0	-	9.2	ns
		DIR to B ^[1]	-	20.7	-	17.6	-	11.6	-	9.9	-	8.9	ns

Note: [1] t_{PZH} and t_{PZL} are calculated values using the formula shown in Section 6.4.



3.3.8. AC Characteristics 5

($T_{amb} = -40^{\circ}\text{C}$ to $+105^{\circ}\text{C}$, voltages are referenced to GND (ground=0V), unless otherwise specified)

Parameter	Symbol	Conditions	$V_{CC(B)}$										Unit
			1.5V±0.1V		1.8V±0.15V		2.5V±0.2V		3.3V±0.3V		5.0V±0.5V		
			Min.	Max.	Min.	Max.	Min.	Max.	Min.	Max.	Min.	Max.	
$V_{CC(A)} = 1.4\text{V to } 1.6\text{V}$													
LOW to HIGH propagation delay	t_{PLH}	A to B	2.5	23.5	2.1	19.4	1.8	14.9	1.5	13.0	1.4	11.6	ns
		B to A	2.5	23.5	2.3	21.1	2.0	16.4	2.0	13.7	1.9	13.2	ns
HIGH to LOW propagation delay	t_{PHL}	A to B	2.3	21.3	1.9	16.9	1.6	13.0	1.5	12.0	1.5	11.9	ns
		B to A	2.3	21.3	2.1	19.1	2.0	14.6	1.9	12.5	2.0	12.1	ns
HIGH to OFF-state propagation delay	t_{PHZ}	DIR to A	2.7	20.6	2.7	20.6	2.7	20.6	2.7	20.6	2.7	20.6	ns
		DIR to B	3.1	27.3	3.1	26.0	2.7	12.1	2.9	12.5	2.5	11.4	ns
LOW to OFF-state propagation delay	t_{PLZ}	DIR to A	2.1	12.6	2.1	12.6	2.1	12.6	2.1	12.6	2.1	12.6	ns
		DIR to B	2.5	20.2	2.7	19.0	2.2	10.4	2.7	11.2	2.2	10.4	ns
OFF-state to HIGH propagation delay	t_{PZH}	DIR to A ^[1]	-	43.7	-	40.1	-	26.8	-	24.9	-	23.6	ns
		DIR to B ^[1]	-	36.1	-	32.0	-	27.5	-	25.6	-	24.2	ns
OFF-state to LOW propagation delay	t_{PZL}	DIR to A ^[1]	-	48.6	-	45.1	-	26.7	-	25.0	-	23.5	ns
		DIR to B ^[1]	-	41.9	-	37.5	-	33.6	-	32.6	-	32.5	ns
$V_{CC(A)} = 1.65\text{V to } 1.95\text{V}$													
LOW to HIGH propagation delay	t_{PLH}	A to B	2.3	21.1	1.9	19.5	1.9	10.3	1.5	8.0	1.2	7.5	ns
		B to A	2.1	19.4	1.9	19.5	2.0	17.6	1.8	17.1	1.7	16.7	ns
HIGH to LOW propagation delay	t_{PHL}	A to B	2.1	19.1	1.8	15.8	1.4	9.4	1.6	7.9	1.5	7.7	ns
		B to A	1.9	16.9	1.8	15.8	1.8	14.2	1.8	13.9	1.6	13.5	ns
HIGH to OFF-state propagation delay	t_{PHZ}	DIR to A	2.6	18.9	2.6	18.9	2.6	18.9	2.6	18.9	2.6	18.9	ns
		DIR to B	2.8	26.6	2.8	24.1	2.4	12.7	2.7	11.4	2.2	9.1	ns
LOW to OFF-state propagation delay	t_{PLZ}	DIR to A	2.1	11.6	2.1	11.6	2.1	11.6	2.1	11.6	2.1	11.6	ns
		DIR to B	2.2	19.4	2.3	17.6	1.9	10.2	2.4	9.3	2.1	7.9	ns
OFF-state to HIGH propagation delay	t_{PZH}	DIR to A ^[1]	-	38.8	-	37.1	-	27.8	-	26.4	-	24.6	ns
		DIR to B ^[1]	-	32.7	-	31.1	-	21.9	-	19.6	-	19.1	ns
OFF-state to	t_{PZL}	DIR to A ^[1]	-	43.5	-	39.9	-	26.9	-	25.3	-	22.6	ns



Wuxi I-CORE Electronics Co., Ltd.

Tab: 835-12

rev:B3

Number: AiP74LVC/LVCH2T45-AX-LJ-B082EN

LOW propagation delay		DIR to B ^[1]	-	38.0	-	34.7	-	28.3	-	26.8	-	26.6	ns
V_{CC(A)}=2.3V to 2.7V													
LOW to HIGH propagation delay	t _{PLH}	A to B	2.0	19.7	2.0	17.6	1.3	9.4	1.1	6.9	0.9	5.3	ns
		B to A	1.8	14.9	1.9	10.3	1.3	9.4	1.2	8.8	0.9	8.3	ns
HIGH to LOW propagation delay	t _{PHL}	A to B	2.0	17.4	1.8	14.2	1.2	8.3	1.1	6.0	0.8	5.1	ns
		B to A	1.6	13.0	1.7	9.4	1.2	8.3	1.1	7.7	0.8	6.9	ns
HIGH to OFF-state propagation delay	t _{PHZ}	DIR to A	1.8	9.0	1.8	9.0	1.8	9.0	1.8	9.0	1.8	9.0	ns
		DIR to B	2.7	24.8	2.7	23.6	2.2	12.1	2.5	10.3	2.0	7.6	ns
LOW to OFF-state propagation delay	t _{PLZ}	DIR to A	1.5	6.4	1.5	6.4	1.5	6.4	1.5	6.4	1.5	6.4	ns
		DIR to B	2.0	16.1	2.2	14.6	1.8	9.9	2.2	9.3	1.6	6.4	ns
OFF-state to HIGH propagation delay	t _{PZH}	DIR to A ^[1]	-	31.0	-	24.9	-	19.3	-	18.1	-	14.7	ns
		DIR to B ^[1]	-	26.1	-	24.0	-	15.8	-	13.3	-	11.7	ns
OFF-state to LOW propagation delay	t _{PZL}	DIR to A ^[1]	-	37.8	-	33.0	-	20.4	-	18.0	-	14.5	ns
		DIR to B ^[1]	-	26.4	-	23.2	-	17.3	-	15.0	-	14.1	ns
V_{CC(A)}=3.0V to 3.6V													
LOW to HIGH propagation delay	t _{PLH}	A to B	2.0	18.9	1.8	17.1	1.2	8.8	0.7	6.2	0.6	4.9	ns
		B to A	1.5	13.0	1.5	8.0	1.1	6.9	0.6	6.2	0.5	6.0	ns
HIGH to LOW propagation delay	t _{PHL}	A to B	1.9	17.2	1.8	13.9	1.1	7.7	0.7	5.5	0.6	4.4	ns
		B to A	1.5	12.0	1.6	7.9	1.1	6.0	0.7	5.5	0.6	5.0	ns
HIGH to OFF-state propagation delay	t _{PHZ}	DIR to A	2.0	8.1	2.0	8.1	2.0	8.1	2.0	8.1	2.4	8.1	ns
		DIR to B	2.6	19.8	2.6	18.2	2.0	11.2	2.4	9.5	1.9	7.0	ns
LOW to OFF-state propagation delay	t _{PLZ}	DIR to A	1.8	6.2	1.8	6.2	1.8	6.2	1.8	6.2	1.8	6.2	ns
		DIR to B	2.0	15.0	2.1	13.8	1.7	8.6	2.0	7.9	1.5	5.4	ns
OFF-state to HIGH propagation delay	t _{PZH}	DIR to A ^[1]	-	28.0	-	21.8	-	15.5	-	14.1	-	11.4	ns
		DIR to B ^[1]	-	25.1	-	23.3	-	15.0	-	12.4	-	11.1	ns
OFF-state to LOW propagation delay	t _{PZL}	DIR to A ^[1]	-	31.8	-	26.1	-	17.2	-	15.0	-	12.0	ns
		DIR to B ^[1]	-	25.3	-	22.0	-	15.8	-	13.6	-	12.5	ns
V_{CC(A)}=4.5V to 5.5V													



LOW to HIGH propagation delay	t_{PLH}	A to B	1.9	18.3	1.7	16.7	0.9	8.3	0.6	6.0	0.4	4.3	ns
		B to A	1.4	11.6	1.2	7.5	0.9	5.3	0.6	4.9	0.4	4.3	ns
HIGH to LOW propagation delay	t_{PHL}	A to B	2.0	16.9	1.6	13.5	0.9	6.9	0.6	5.0	0.4	3.9	ns
		B to A	1.5	11.9	1.5	7.7	0.8	5.1	0.6	4.4	0.4	3.9	ns
HIGH to OFF-state propagation delay	t_{PHZ}	DIR to A	1.5	6.0	1.5	6.0	1.5	6.0	1.5	6.0	1.5	6.0	ns
		DIR to B	2.6	19.1	2.6	17.8	2.0	10.7	2.4	8.8	2.2	6.3	ns
LOW to OFF-state propagation delay	t_{PLZ}	DIR to A	1.2	4.1	1.2	4.1	1.1	4.1	0.9	4.1	0.8	4.1	ns
		DIR to B	2.0	14.5	2.1	13.4	1.7	8.2	2.0	7.7	1.6	5.0	ns
OFF-state to HIGH propagation delay	t_{PZH}	DIR to A ^[1]	-	26.1	-	20.9	-	13.5	-	12.6	-	9.3	ns
		DIR to B ^[1]	-	22.4	-	20.8	-	12.4	-	10.1	-	8.4	ns
OFF-state to LOW propagation delay	t_{PZL}	DIR to A ^[1]	-	31.0	-	25.5	-	15.8	-	13.2	-	10.2	ns
		DIR to B ^[1]	-	22.9	-	19.5	-	12.9	-	11.0	-	9.9	ns

Note: [1] t_{PZH} and t_{PZL} are calculated values using the formula shown in Section 6.4.

4. Testing Circuit

4.1. AC Testing Circuit

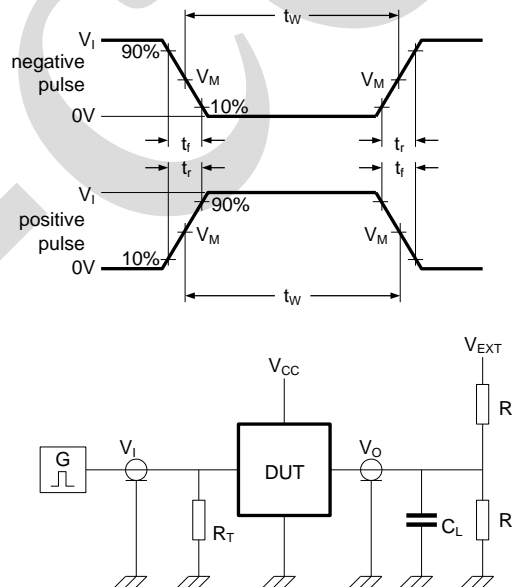

R_L =Load resistance.

C_L =Load capacitance including jig and probe capacitance.

R_T =Termination resistance.

V_{EXT} =External voltage for measuring switching times.

Figure 3. Test circuit for measuring switching times



4.2、 Test Data

Supply voltage	Input		Load		V_{EXT}		
$V_{CC(A)}, V_{CC(B)}$	$V_I^{[1]}$	$\Delta t/\Delta V^{[2]}$	C_L	R_L	t_{PLH}, t_{PHL}	t_{PZH}, t_{PHZ}	$t_{PZL}, t_{PLZ}^{[3]}$
1.2V to 5.5V	V_{CCI}	$\leq 1.0\text{ns/V}$	15pF	2k Ω	open	GND	$2V_{CCO}$

Note:

[1] V_{CCI} is the supply voltage associated with the data input port.

[2] $dV/dt \geq 1.0\text{V/ns}$.

[3] V_{CCO} is the supply voltage associated with the output port.

4.3、 AC Testing Waveforms

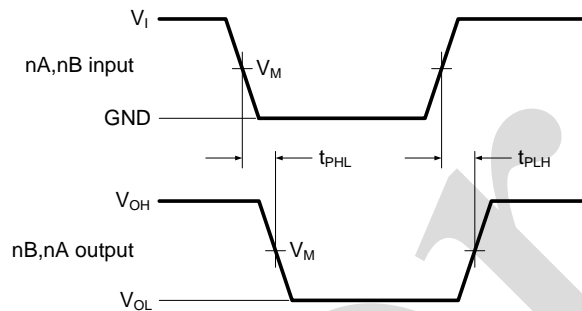

Figure 4. The data input (A, B) to output (B, A) propagation delay times

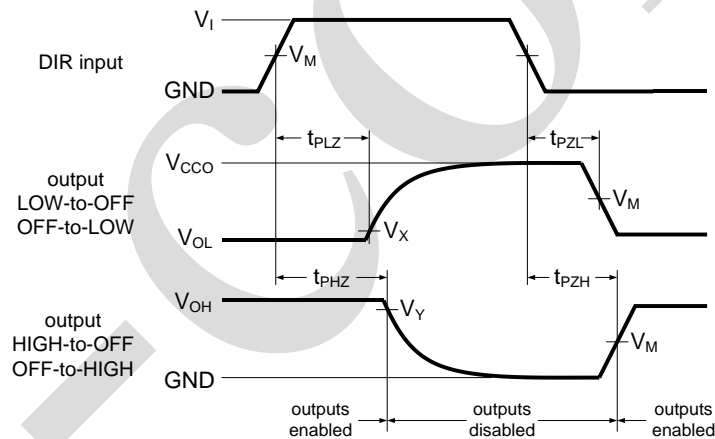

Figure 5. Enable and disable times

4.4、 Measurement Points

Supply voltage	Input ^[1]	Output ^[2]		
$V_{CC(A)}, V_{CC(B)}$	V_M	V_M	V_X	V_Y
1.2V to 1.6V	$0.5V_{CCI}$	$0.5V_{CCO}$	$V_{OL}+0.1\text{V}$	$V_{OH}-0.1\text{V}$
1.65V to 2.7V	$0.5V_{CCI}$	$0.5V_{CCO}$	$V_{OL}+0.15\text{V}$	$V_{OH}-0.15\text{V}$
3.0V to 5.5V	$0.5V_{CCI}$	$0.5V_{CCO}$	$V_{OL}+0.3\text{V}$	$V_{OH}-0.3\text{V}$

Note:

[1] V_{CCI} is the supply voltage associated with the data input port.

[2] V_{CCO} is the supply voltage associated with the output port.



5、Characteristic Curve

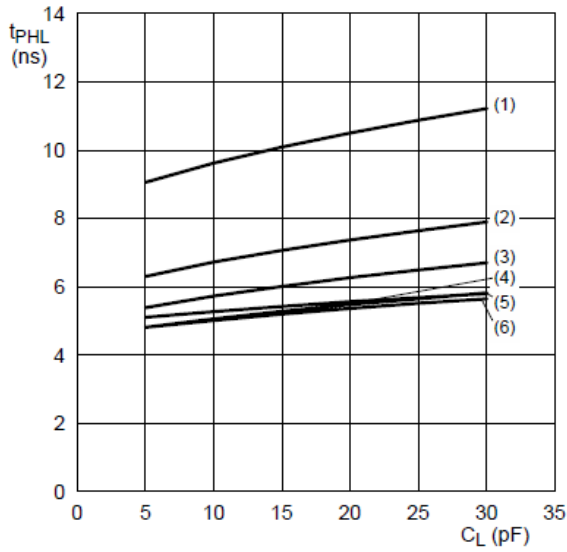

a. HIGH to LOW propagation delay (A to B)

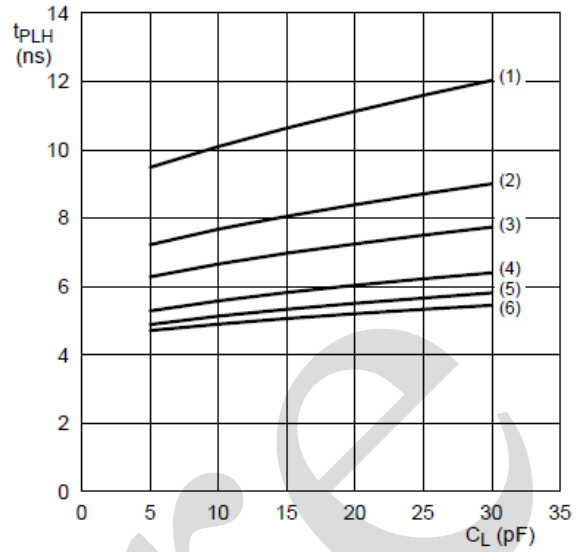

b. LOW to HIGH propagation delay (A to B)

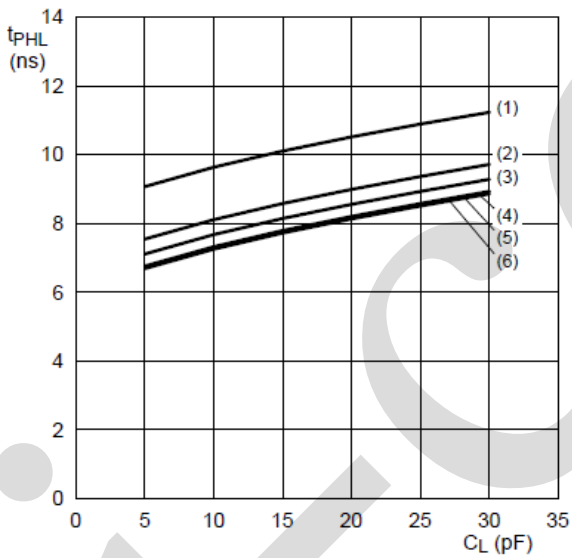

c. HIGH to LOW propagation delay (B to A)

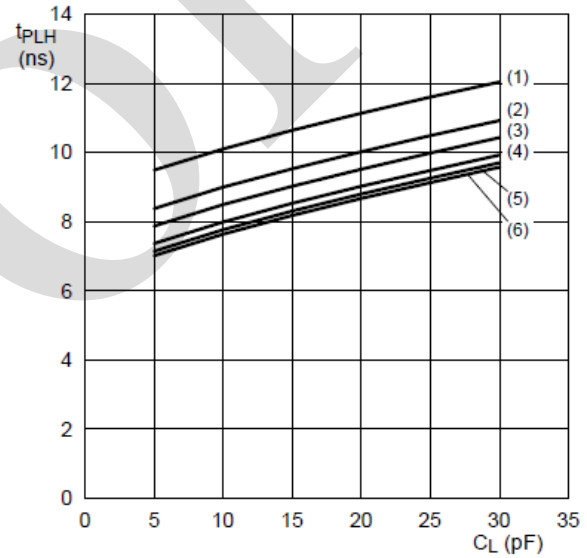

d. LOW to HIGH propagation delay (B to A)

- (1) $V_{CC(B)}=1.2V$.
- (2) $V_{CC(B)}=1.5V$.
- (3) $V_{CC(B)}=1.8V$.
- (4) $V_{CC(B)}=2.5V$.
- (5) $V_{CC(B)}=3.3V$.
- (6) $V_{CC(B)}=5.0V$.

Figure 6. Typical propagation delay versus load capacitance; $T_{amb}=25^{\circ}C$; $V_{CC(A)}=1.2V$

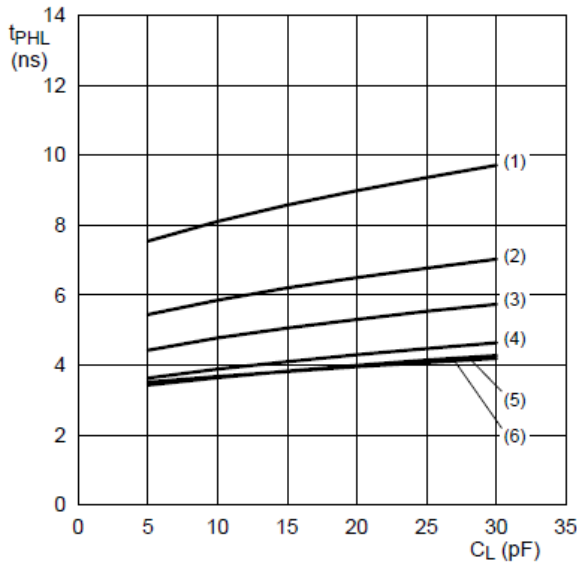

a. HIGH to LOW propagation delay (A to B)

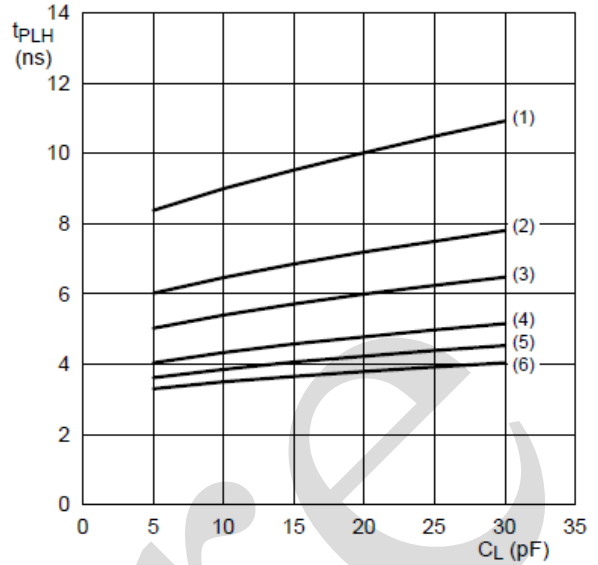

b. LOW to HIGH propagation delay (A to B)

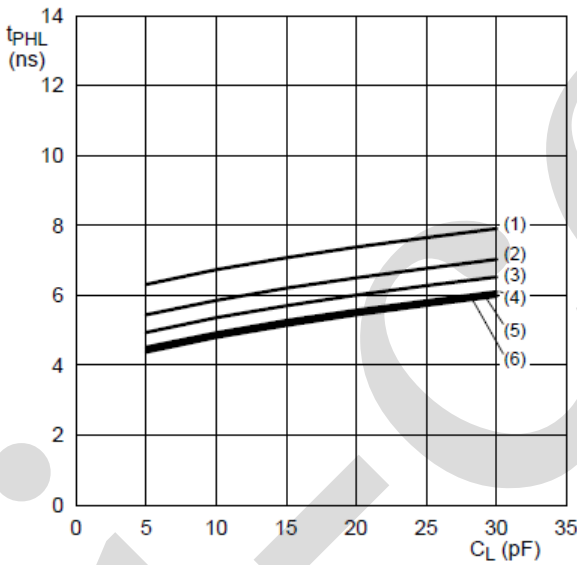

c. HIGH to LOW propagation delay (B to A)

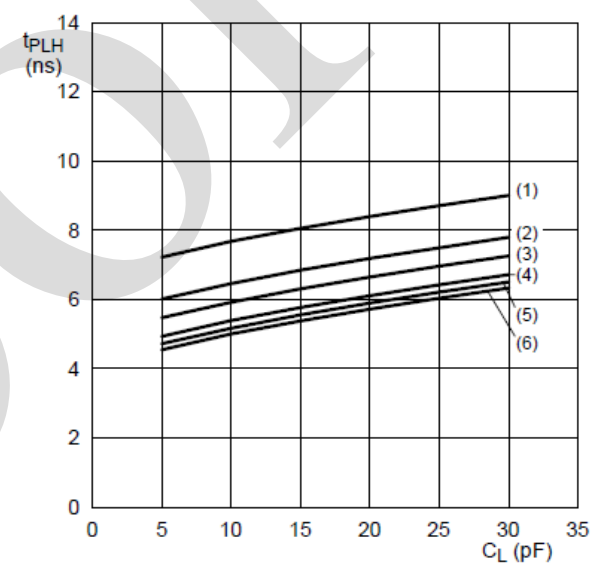

d. LOW to HIGH propagation delay (B to A)

- (1) $V_{CC(B)}=1.2V$.
- (2) $V_{CC(B)}=1.5V$.
- (3) $V_{CC(B)}=1.8V$.
- (4) $V_{CC(B)}=2.5V$.
- (5) $V_{CC(B)}=3.3V$.
- (6) $V_{CC(B)}=5.0V$.

Figure 7. Typical propagation delay versus load capacitance; $T_{amb}=25^{\circ}C$; $V_{CC(A)}=1.5V$

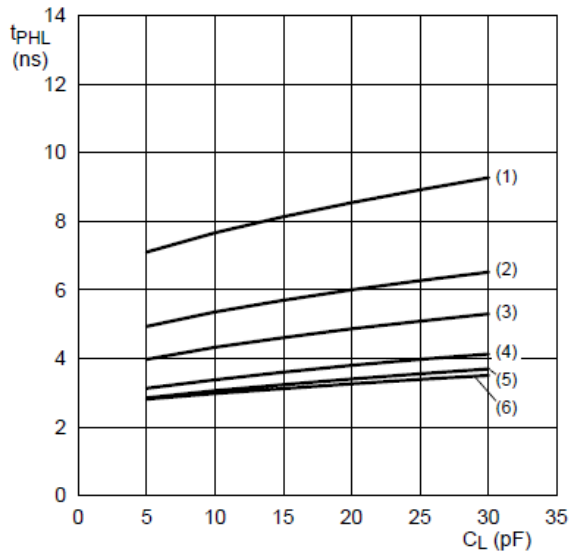

a. HIGH to LOW propagation delay (A to B)

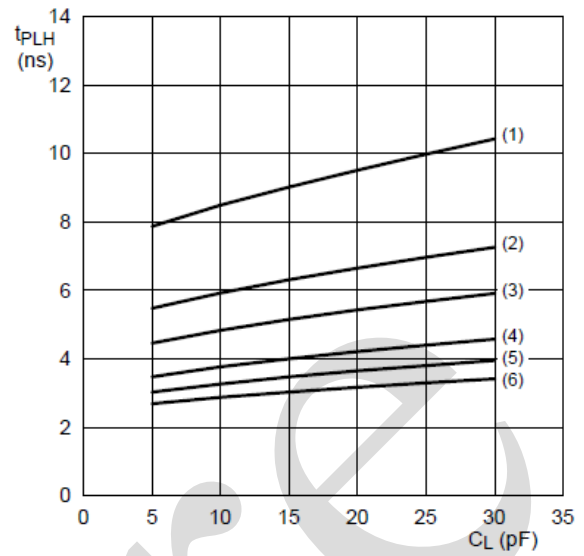

b. LOW to HIGH propagation delay (A to B)

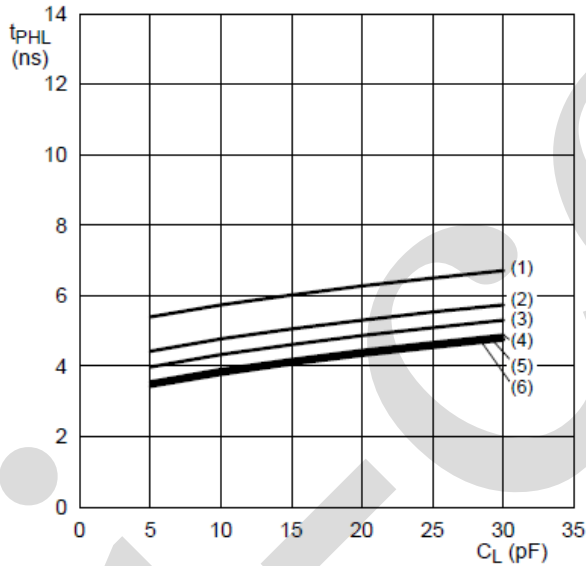

c. HIGH to LOW propagation delay (B to A)

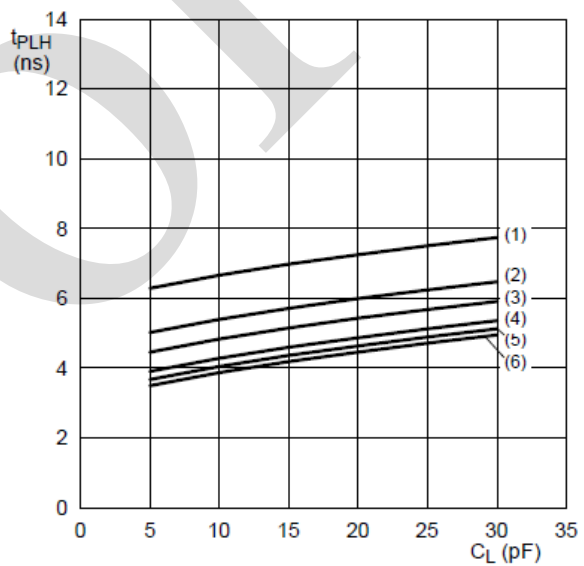

d. LOW to HIGH propagation delay (B to A)

- (1) $V_{CC(B)}=1.2V$.
- (2) $V_{CC(B)}=1.5V$.
- (3) $V_{CC(B)}=1.8V$.
- (4) $V_{CC(B)}=2.5V$.
- (5) $V_{CC(B)}=3.3V$.
- (6) $V_{CC(B)}=5.0V$.

Figure 8. Typical propagation delay versus load capacitance; $T_{amb}=25^{\circ}C$; $V_{CC(A)}=1.8V$

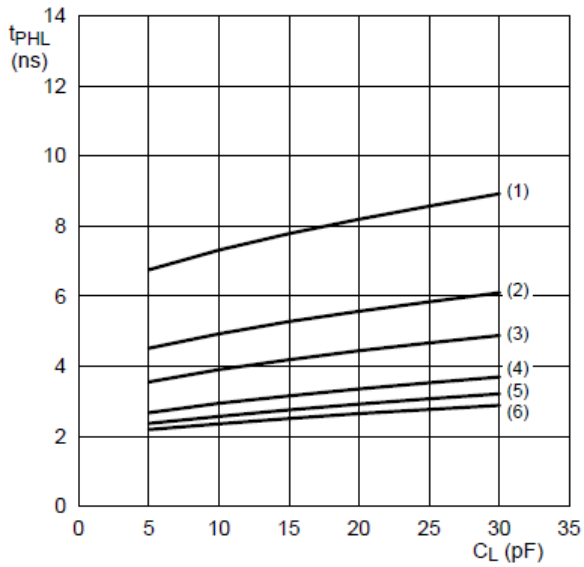

a. HIGH to LOW propagation delay (A to B)

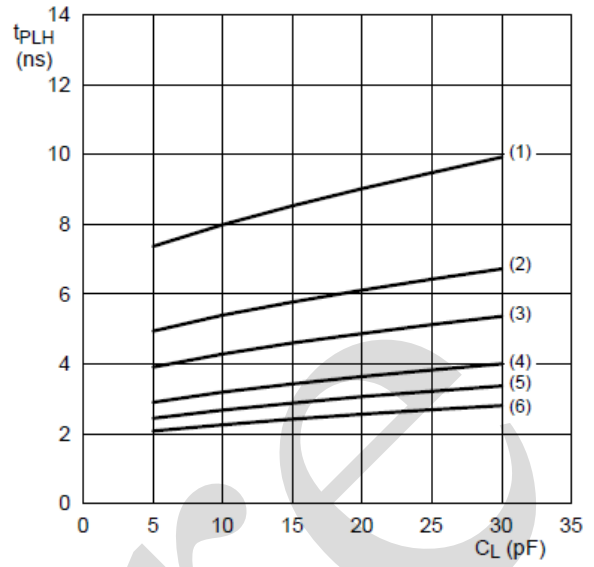

b. LOW to HIGH propagation delay (A to B)

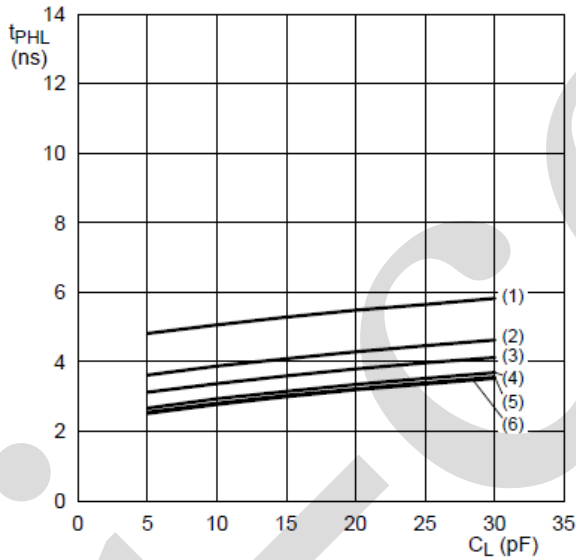

c. HIGH to LOW propagation delay (B to A)

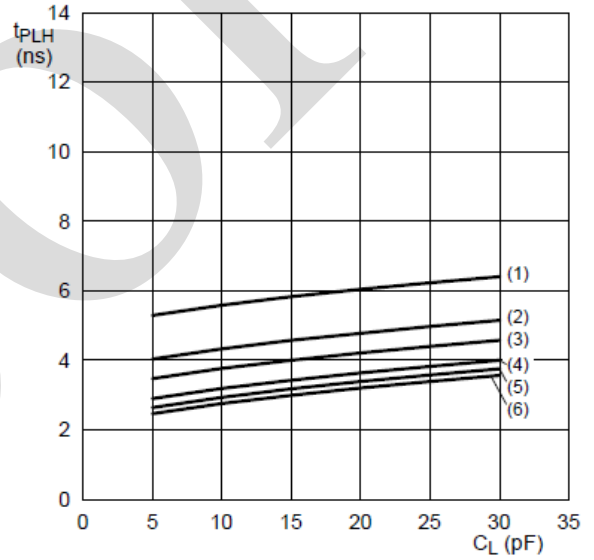

d. LOW to HIGH propagation delay (B to A)

- (1) $V_{CC(B)}=1.2V$.
- (2) $V_{CC(B)}=1.5V$.
- (3) $V_{CC(B)}=1.8V$.
- (4) $V_{CC(B)}=2.5V$.
- (5) $V_{CC(B)}=3.3V$.
- (6) $V_{CC(B)}=5.0V$.

Figure 9. Typical propagation delay versus load capacitance; $T_{amb}=25^{\circ}C$; $V_{CC(A)}=2.5V$

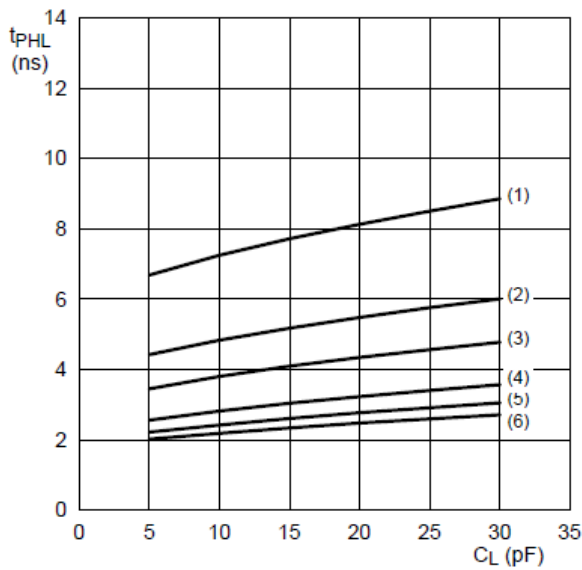

a. HIGH to LOW propagation delay (A to B)

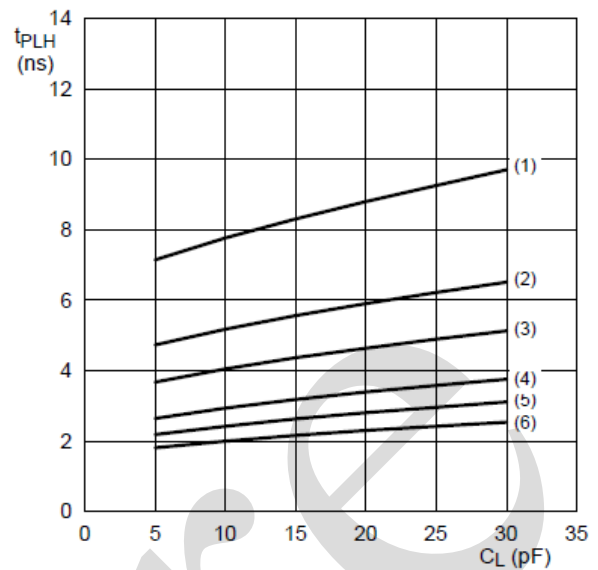

b. LOW to HIGH propagation delay (A to B)

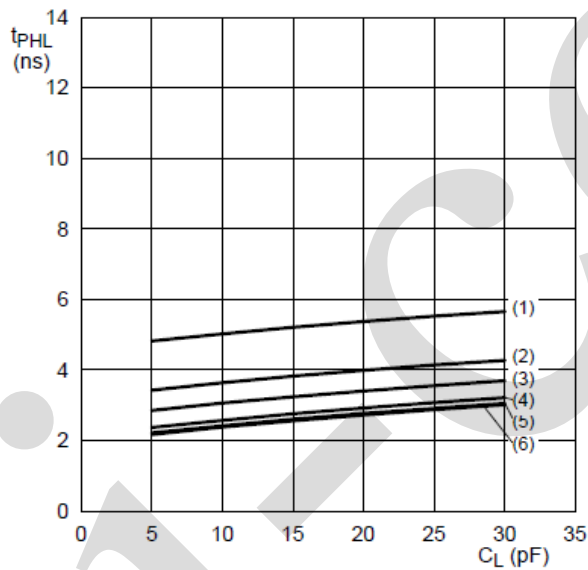

c. HIGH to LOW propagation delay (B to A)

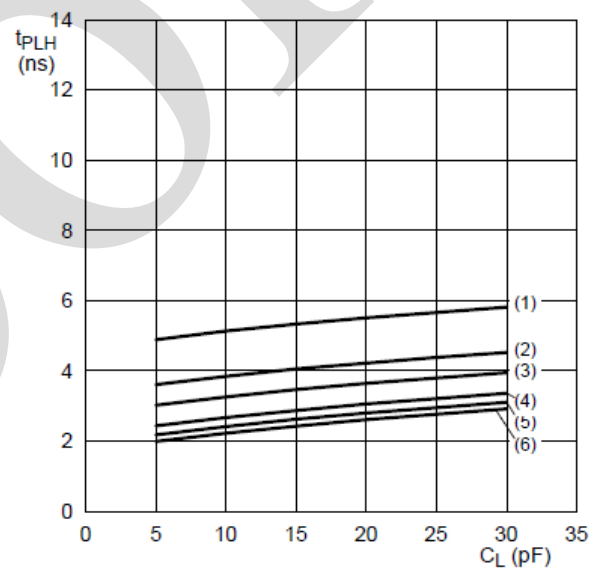

d. LOW to HIGH propagation delay (B to A)

(1) $V_{CC(B)}=1.2V$.

(2) $V_{CC(B)}=1.5V$.

(3) $V_{CC(B)}=1.8V$.

(4) $V_{CC(B)}=2.5V$.

(5) $V_{CC(B)}=3.3V$.

(6) $V_{CC(B)}=5.0V$.

Figure 10. Typical propagation delay versus load capacitance; $T_{amb}=25^{\circ}C$; $V_{CC(A)}=3.3V$

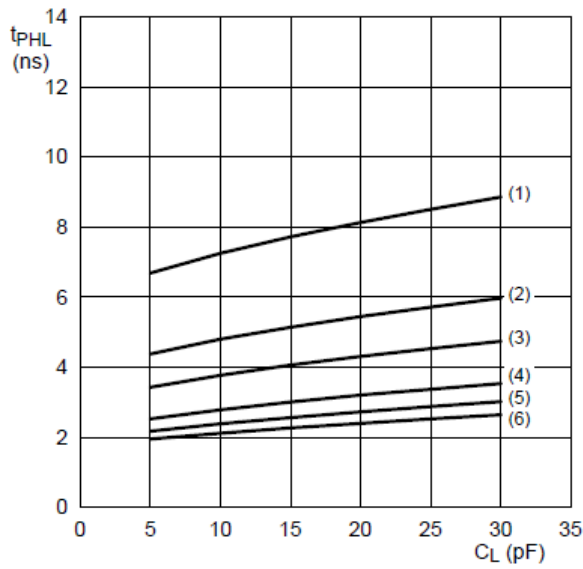

a. HIGH to LOW propagation delay (A to B)

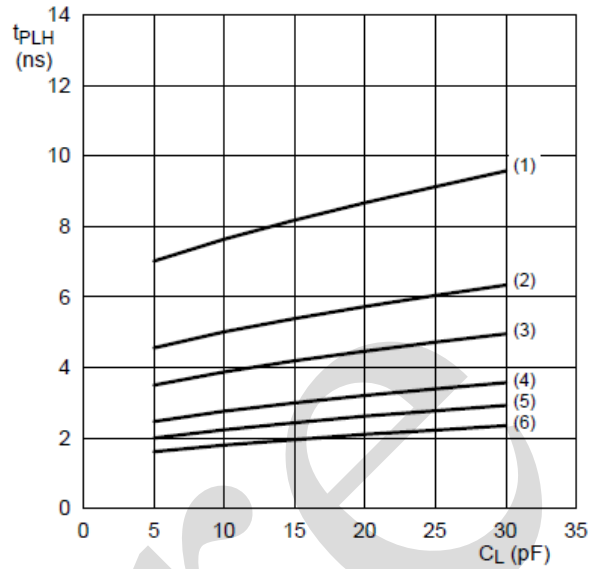

b. LOW to HIGH propagation delay (A to B)

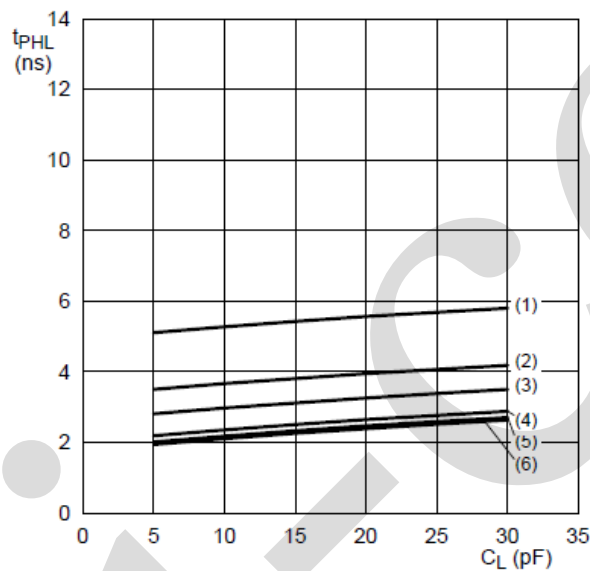

c. HIGH to LOW propagation delay (B to A)

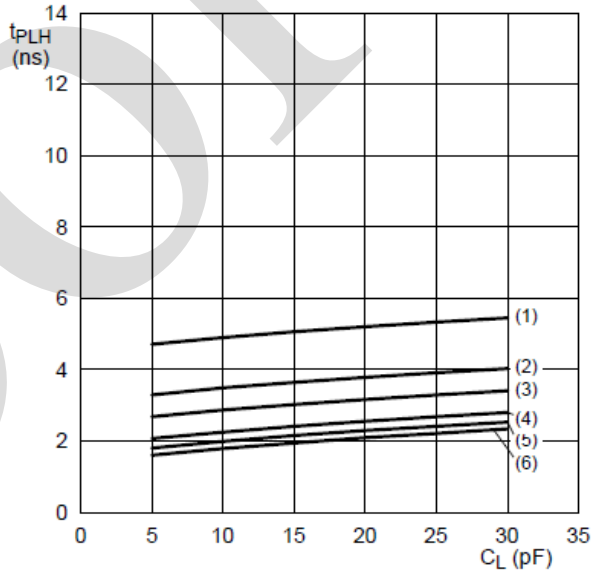

d. LOW to HIGH propagation delay (B to A)

- (1) $V_{CC(B)}=1.2V$.
- (2) $V_{CC(B)}=1.5V$.
- (3) $V_{CC(B)}=1.8V$.
- (4) $V_{CC(B)}=2.5V$.
- (5) $V_{CC(B)}=3.3V$.
- (6) $V_{CC(B)}=5.0V$.

Figure 11. Typical propagation delay versus load capacitance; $T_{amb}=25^{\circ}C$; $V_{CC(A)}=5.0V$



6、 Typical Application Circuit And Application Note

6.1、 Unidirectional Logic Level-shifting Application

The circuit given in Figure 12 is an example of the AiP74LVC2T45; AiP74LVCH2T45 being used in a unidirectional logic level-shifting application.

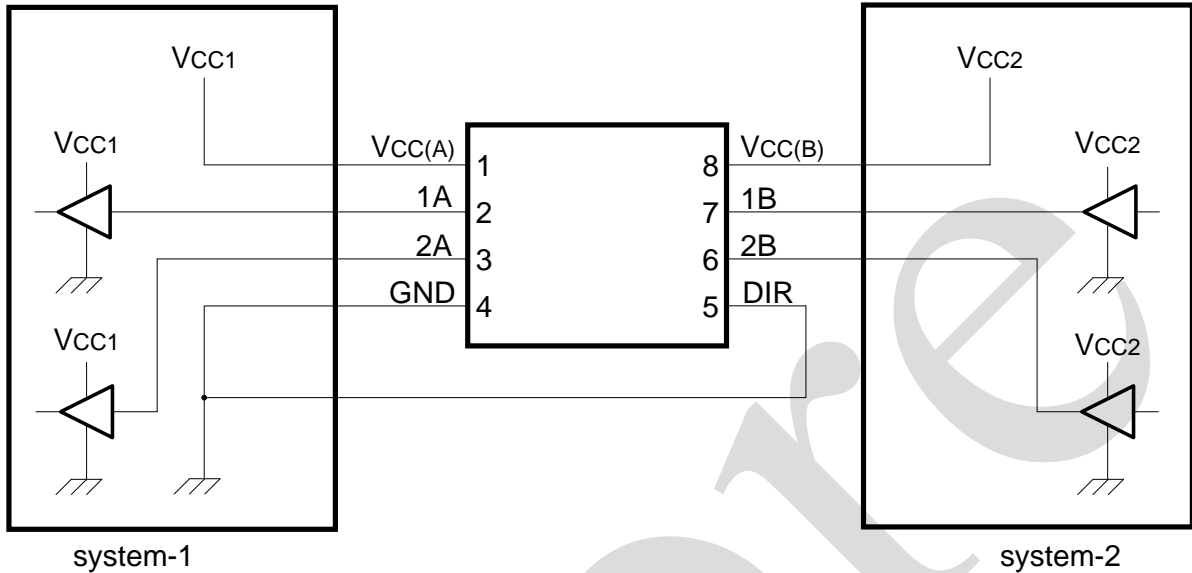

Figure 12. Unidirectional logic level-shifting application

Table 1. Description of unidirectional logic level-shifting application

Pin	Name	Function	Description
1	V _{CC(A)}	V _{CC1}	supply voltage of system-1 (1.2V to 5.5V)
2	1A	OUT	output level depends on V _{CC1} voltage
3	2A	OUT	output level depends on V _{CC1} voltage
4	GND	GND	device GND
5	DIR	DIR	the GND (LOW level) determines B port to A port direction
6	2B	IN	input threshold value depends on V _{CC2} voltage
7	1B	IN	input threshold value depends on V _{CC2} voltage
8	V _{CC(B)}	V _{CC2}	supply voltage of system-2 (1.2V to 5.5V)



6.2、 Bidirectional Logic Level-shifting Application

Figure 13 shows the AiP74LVC2T45; AiP74LVCH2T45 being used in a bidirectional logic level-shifting application. Since the device does not have an output enable pin, the system designer should take precautions to avoid bus contention between system-1 and system-2 when changing directions.

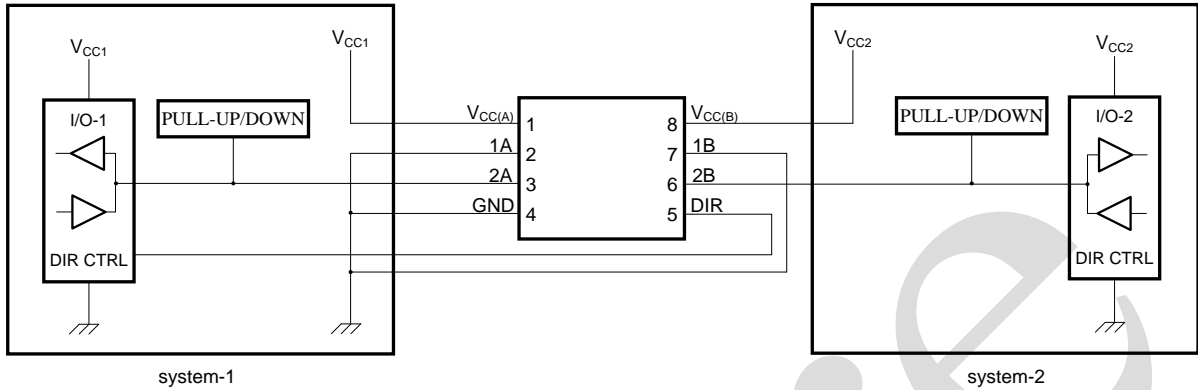

Pull-up or pull-down only needed for AiP74LVC2T45.

Figure 13. Bidirectional logic level-shifting application

Table 2 gives a sequence that will illustrate data transmission from system-1 to system-2 and then from system-2 to system-1.

Table 2. Description of bidirectional logic level-shifting application

State	DIR CTRL	I/O-1	I/O-2	Description
1	H	output	input	system-1 data to system-2
2	H	Z	Z	system-2 is getting ready to send data to system-1. I/O-1 and I/O-2 are disabled. The bus-line state depends on bus hold.
3	L	Z	Z	DIR bit is set LOW. I/O-1 and I/O-2 still are disabled. The bus-line state depends on bus hold.
4	L	input	output	system-2 data to system-1

Note:

H=HIGH voltage level;

L=LOW voltage level;

Z=high-impedance OFF-state.



6.3、Power-up Considerations

The device is designed such that no special power-up sequence is required other than GND being applied first.

Table 3. Typical total supply current ($I_{CC(A)}+I_{CC(B)}$)

$V_{CC(A)}$	$V_{CC(B)}$					Unit
	0V	0.8V	2.5V	3.3V	5.0V	
0V	0	<1	<1	<1	<1	uA
1.8V	<1	<2	<2	<2	2	uA
2.5V	<1	<2	<2	<2	<2	uA
3.3V	<1	<2	<2	<2	<2	uA
5.0V	<1	2	<2	<2	<2	uA

6.4、Enable Times

Calculate the enable times for the AiP74LVC2T45; AiP74LVCH2T45 using the following formulas:

- $t_{PZH}(\text{DIR to A})=t_{PLZ}(\text{DIR to B})+t_{PLH}(\text{B to A})$
- $t_{PZL}(\text{DIR to A})=t_{PHZ}(\text{DIR to B})+t_{PHL}(\text{B to A})$
- $t_{PZH}(\text{DIR to B})=t_{PLZ}(\text{DIR to A})+t_{PLH}(\text{A to B})$
- $t_{PZL}(\text{DIR to B})=t_{PHZ}(\text{DIR to A})+t_{PHL}(\text{A to B})$

In a bidirectional application, these enable times provide the maximum delay from the time the DIR bit is switched until an output is expected. For example, if the AiP74LVC2T45; AiP74LVCH2T45 initially is transmitting from A to B, then the DIR bit is switched, the B port of the device must be disabled before presenting it with an input. After the B port has been disabled, an input signal applied to it appears on the corresponding A port after the specified propagation delay.



7、Package Information

7.1、VSSOP8

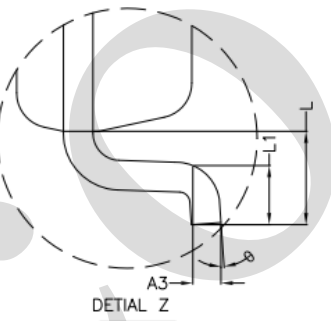
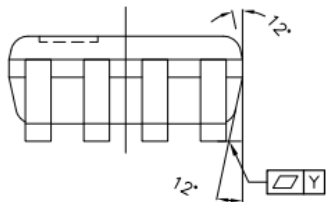
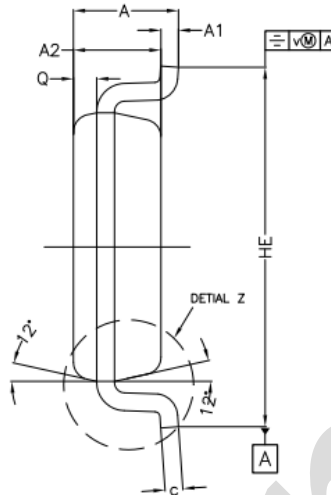
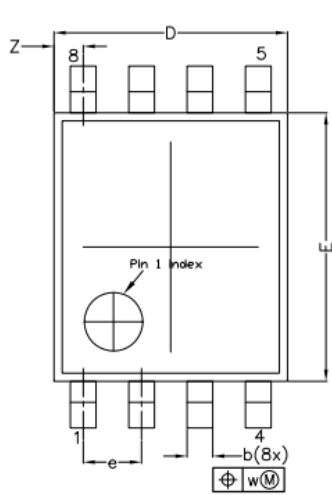

* CONTROLLING DIMENSION : MM

SYMBOL	MILLIMETER		
	MIN.	NOM.	MAX.
A	---	---	1.00
A1	0.00	---	0.15
A2	0.60	0.75	0.85
A3	---	0.12	---
Q	0.19	0.20	0.21
b	0.17	0.22	0.27
c	0.08	---	0.23
D	1.90	2.00	2.10
E	2.20	2.30	2.40
HE	3.00	3.10	3.20
e	0.50 bsc		
L	0.40 bsc		
L1	0.15	---	0.40
Y	---	0.10	---
v	---	0.20	---
w	---	0.08	---
Z	0.10	---	0.40
θ	0°	---	8°

NOTES

1.0 COPLANARITY APPLIES TO LEADS, CORNER LEADS AND DIE ATTACH PAD.



7.2、TSSOP8

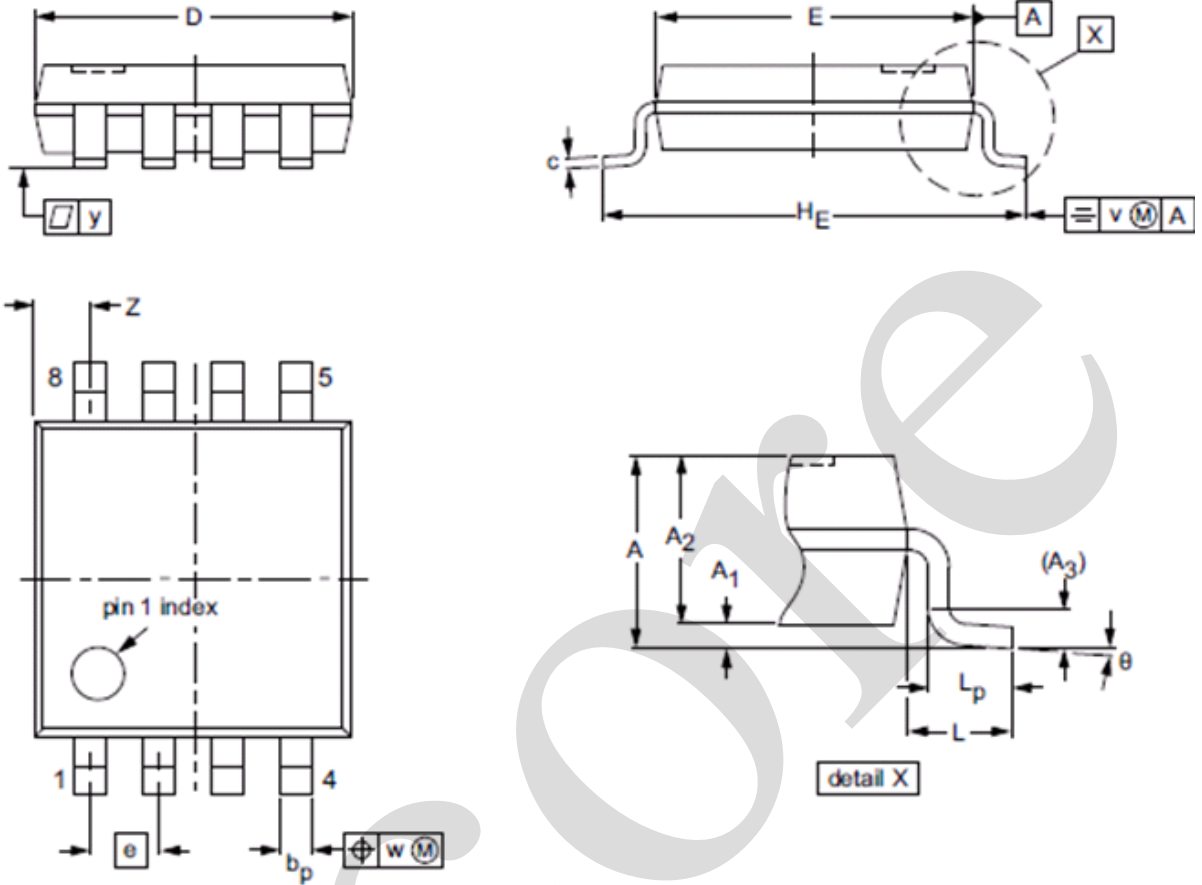

UNIT	A max.	A ₁	A ₂	A ₃	b _p	c	D ⁽¹⁾	E ⁽¹⁾	e	H _E	L	L _p	v	w	y	Z ⁽¹⁾	θ
mm	1.1	0.15 0.00	0.95 0.75	0.25	0.38 0.22	0.18 0.08	3.1 2.9	3.1 2.9	0.65	4.1 3.9	0.5	0.47 0.33	0.2	0.13	0.1	0.70 0.35	8° 0°



8、 Statements And Notes

8.1、 The name and content of Hazardous substances or Elements in the product

Part name	Hazardous substances or Elements									
	Lead and lead compounds	Mercury and mercury compounds	Cadmium and cadmium compounds	Hexavalent chromium compounds	Polybrominated biphenyls	Polybrominated biphenyl ethers	Dibutyl phthalate	Butylbenzyl phthalate	Di-2-ethylhexyl phthalate	Diisobutyl phthalate
Lead frame	○	○	○	○	○	○	○	○	○	○
Plastic resin	○	○	○	○	○	○	○	○	○	○
Chip	○	○	○	○	○	○	○	○	○	○
The lead	○	○	○	○	○	○	○	○	○	○
Plastic sheet installed	○	○	○	○	○	○	○	○	○	○
explanation	○: Indicates that the content of hazardous substances or elements in the detection limit of the following the SJ/T11363-2006 standard. ×: Indicates that the content of hazardous substances or elements exceeding the SJ/T11363-2006 Standard limit requirements.									

8.2、 Notion

Recommended carefully reading this information before the use of this product;

The information in this document are subject to change without notice;

This information is using to the reference only, the company is not responsible for any loss;

The company is not responsible for the any infringement of the third party patents or other rights of the responsibility.

X-ON Electronics

Largest Supplier of Electrical and Electronic Components

Click to view similar products for [Buffers & Line Drivers](#) category:

Click to view products by [I-core](#) manufacturer:

Other Similar products are found below :

[LXV200-024SW](#) [74AUP2G34FW3-7](#) [HEF4043BP](#) [NL17SG125DFT2G](#) [NLU1GT126CMUTCG](#) [CD4041UBE](#) [54FCT240CTDB](#)
[74HCT540N](#) [DS14C88N](#) [070519XB](#) [NL17SZ07P5T5G](#) [74LVC2G17FW4-7](#) [CD4502BE](#) [5962-8982101PA](#) [61446R00](#) [NL17SH17P5T5G](#)
[NLV37WZ17USG](#) [74HCT126T14-13](#) [74VHC9126FT\(BJ\)](#) [RHRXH162244K1](#) [74AUP1G34FW5-7](#) [74AUP1G07FW5-7](#) [74LVC1G126FW4-7](#)
[74LVC2G126RA3-7](#) [74LVCE1G125FZ4-7](#) [54FCT240TLB](#) [NLX3G16DMUTCG](#) [NLX2G06AMUTCG](#) [LE87100NQCT](#) [LE87285NQC](#)
[LE87290YQC](#) [LE87290YQCT](#) [74AUP1G125FW5-7](#) [NLU2G16CMUTCG](#) [MC74LCX244MN2TWG](#) [NL17SG17P5T5G](#)
[NLV74HC125ADR2G](#) [NLVHCT245ADTR2G](#) [NLVVHC1G126DFT2G](#) [EL5623IRZ](#) [ISL15102AIRZ-T13](#) [ISL1539IRZ-T13](#)
[MC100EP17MNG](#) [MC74HCT365ADR2G](#) [MC74LCX244ADTR2G](#) [NL27WZ126US](#) [NL37WZ16US](#) [NLU1G07MUTCG](#) [NLU2G07MUTCG](#)
[NLX3G17BMX1TCG](#)