



# **CD4528**

## **Dual Monostable Multivibrator**

### **Product Specification**

**Specification Revision History:**

<b>Version</b>	<b>Date</b>	<b>Description</b>
2019-06-A1	2019-06	New
2021-12-A2	2021-12	Modify Ordering Information



## 1、 General Description

The CD4528 is a dual retriggerable-resettable monostable multivibrator. Each multivibrator has an active LOW input ( $\bar{nA}$ ), and active HIGH input ( $nB$ ), an active LOW clear direct input ( $\bar{nCD}$ ), an output ( $nQ$ ) and its complement ( $\bar{nQ}$ ), and two external timing component connecting pins ( $nCEXT$ , always connected to ground, and  $nREXT/CEXT$ ).

An external timing capacitor ( $C_{EXT}$ ) must be connected between  $nCEXT$  and  $nREXT/CEXT$  and an external resistor ( $R_{EXT}$ ) must be connected between  $nREXT/CEXT$  and  $V_{DD}$ . The output pulse duration is determined by the external timing components  $C_{EXT}$  and  $R_{EXT}$ . A HIGH-to-LOW transition on  $\bar{nA}$  when  $nB$  is LOW or a LOW-to-HIGH transition on  $nB$  when  $\bar{nA}$  is HIGH produces a positive pulse (LOW-HIGH-LOW) on  $nQ$  and a negative pulse (HIGH-LOW-HIGH) on  $\bar{nQ}$  if the  $\bar{nCD}$  is HIGH. A LOW on  $\bar{nCD}$  forces  $nQ$  LOW,  $\bar{nQ}$  HIGH and inhibits any further pulses until  $\bar{nCD}$  is HIGH. It operates over a recommended  $V_{DD}$  power supply range of 3V to 12V referenced to  $V_{SS}$  (usually ground). Unused inputs must be connected to  $V_{DD}$ ,  $V_{SS}$ , or another input.

### Features:

- Wide supply voltage range from 3V to 12V
- Fully static operation
- 5V and 10V parametric ratings
- Standardized symmetrical output characteristics
- Specified from  $-40^{\circ}\text{C}$  to  $+85^{\circ}\text{C}$
- Packaging information: DIP16/SOP16/TSSOP16

**Ordering Information:****Tube packing specifications:**

Part number	Packaging form	Marking code	Tube quantity	Boxed tube quantity	Boxed quantity	Notes
CD4528DA16.TB	DIP16	CD4528	25 PCS/tube	40 tube/box	1000 PCS/box	Dimensions of plastic enclosure: 19.0mm×6.4mm Pin spacing: 2.54mm
CD4528SA16.TB	SOP16	CD4528	50 PCS/tube	200 tube/box	10000 PCS/box	Dimensions of plastic enclosure: 10.0mm×3.9mm Pin spacing: 1.27mm
CD4528TA16.TB	TSSOP16	CD4528	96 PCS/tube	200 tube/box	19200 PCS/box	Dimensions of plastic enclosure: 5.0mm×4.4mm Pin spacing: 0.65mm

**Reel packing specifications:**

Part number	Packaging form	Marking code	Reel quantity	Boxed reel quantity	Notes
CD4528SA16.TR	SOP16	CD4528	4000 PCS/reel	8000 PCS/box	Dimensions of plastic enclosure: 10.0mm×3.9mm Pin spacing:1.27mm
CD4528TA16.TR	TSSOP16	CD4528	5000 PCS/reel	10000 PCS/box	Dimensions of plastic enclosure: 5.0mm×4.4mm Pin spacing:0.65mm

Note: If the physical information is inconsistent with the ordering information, please refer to the actual product.



## 2、Block Diagram And Pin Description

### 2.1、Block Diagram

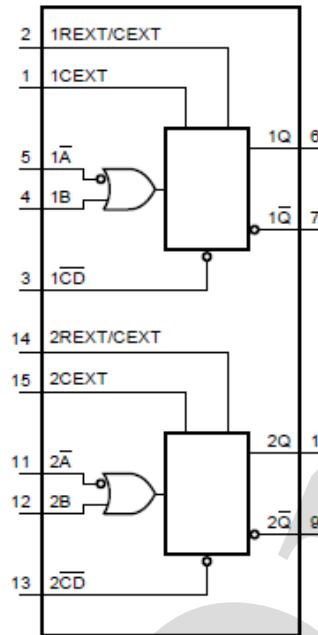

Figure 1. Functional diagram

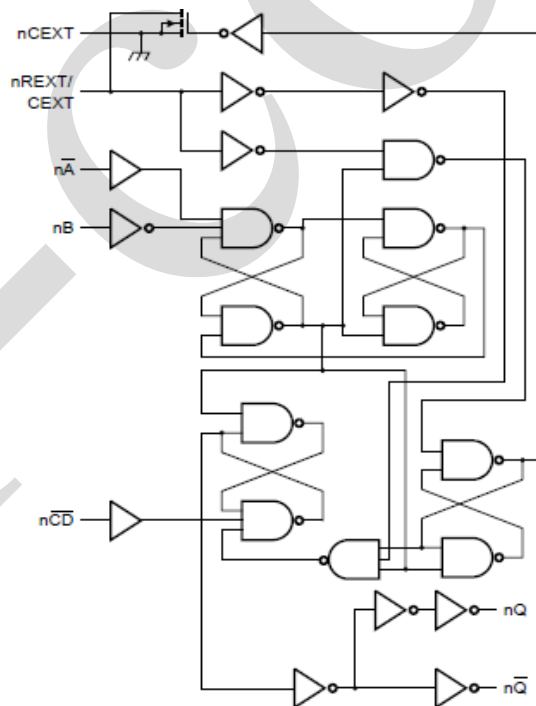
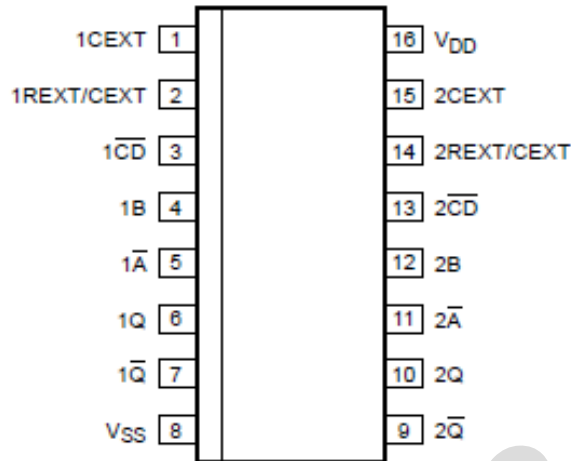

Figure 2. Logic diagram for one monostable multivibrator



## 2.2、Pin Configurations







## 2.3、Pin Description

Pin No.	Pin Name	Description
1	1CEXT	external capacitor connection (always connected to ground)
2	1REXT/CEXT	external capacitor/resistor connection
3	1 $\overline{CD}$	clear direct input (active LOW)
4	1B	input (LOW-to-HIGH triggered)
5	1 $\overline{A}$	input (HIGH-to-LOW triggered)
6	1Q	output
7	1 $\overline{Q}$	complementary output (active LOW)
8	V <sub>SS</sub>	ground (0V)
9	2 $\overline{Q}$	complementary output (active LOW)
10	2Q	output
11	2 $\overline{A}$	input (HIGH-to-LOW triggered)
12	2B	input (LOW-to-HIGH triggered)
13	2 $\overline{CD}$	clear direct input (active LOW)
14	2REXT/CEXT	external capacitor/resistor connection
15	2CEXT	external capacitor connection (always connected to ground)
16	V <sub>DD</sub>	supply voltage



## 2.4、Function Table

Input			Output	
$\bar{nA}$	nB	$n\bar{CD}$	nQ	$n\bar{Q}$
↓	L	H		
H	↑	H		
X	X	L	L	H

Note:

[1] H=HIGH voltage level; L=LOW voltage level; X=don't care;

[2] ↑=positive-going clock transition; ↓=negative-going transition;

[3]  =one HIGH level output pulse, with the pulse width determined by  $C_{EXT}$  and  $R_{EXT}$ ;

[4]  =one LOW level output pulse, with the pulse width determined by  $C_{EXT}$  and  $R_{EXT}$ .

## 3、Electrical Parameter

### 3.1、Absolute Maximum Ratings

(Voltages are referenced to  $V_{SS}$  (ground=0V), unless otherwise specified.)

Parameter	Symbol	Conditions	Min.	Max.	Unit
supply voltage	$V_{DD}$	-	-0.5	+14	V
DC input current	$I_{IK}$	any one input	-	±10	mA
input voltage	$V_I$	all inputs	-0.5	$V_{DD}+0.5$	V
storage temperature	$T_{stg}$	-	-65	+150	°C
total power dissipation	$P_{tot}$	-	-	500	mW
device dissipation	P	per output transistor	-	100	mW
Soldering temperature	$T_L$	10s	DIP	245	°C
			SOP	250	

Note:

[1] For DIP16 packages: above 70°C the value of  $P_{tot}$  derates linearly with 12mW/K.

[2] For SOP16 packages: above 70°C the value of  $P_{tot}$  derates linearly with 8mW/K.

[3] For (T)SSOP16 packages: above 60°C the value of  $P_{tot}$  derates linearly with 5.5mW/K.

### 3.2、Recommended Operating Conditions

Parameter	Symbol	Conditions	Min.	Typ.	Max.	Unit
supply voltage	$V_{DD}$	-	3	-	12	V
ambient temperature	$T_{amb}$	in free air	-40	-	+85	°C



### 3.3、Electrical Characteristics

#### 3.3.1、DC Characteristics 1

( $T_{amb}=25^{\circ}\text{C}$ , voltages are referenced to  $V_{SS}$  (ground=0V), unless otherwise specified.)

Parameter	Symbol	Conditions			$T_{amb}=25^{\circ}\text{C}$			Unit
		$ I_O (\mu\text{A})$	$V_O(\text{V})$	$V_{DD}(\text{V})$	Min.	Typ.	Max.	
supply current	$I_{DD}$	0	-	5	-	-	20	$\mu\text{A}$
		0	-	10	-	-	40	$\mu\text{A}$
LOW-level output current	$I_{OL}$	-	0.4	5	0.44	-	-	$\text{mA}$
		-	0.5	10	1.1	-	-	$\text{mA}$
HIGH-level output current	$I_{OH}$	-	2.5	5	-	-	-1.4	$\text{mA}$
		-	4.6	5	-	-	-0.44	$\text{mA}$
		-	9.5	10	-	-	-1.1	$\text{mA}$
LOW-level output voltage	$V_{OL}$	<1	-	5	-	-	0.05	V
		<1	-	10	-	-	0.05	V
HIGH-level output voltage	$V_{OH}$	<1	-	5	4.95	-	-	V
		<1	-	10	9.95	-	-	V
LOW-level input voltage	$V_{IL}$	<1	-	5	-	-	1.5	V
		<1	-	10	-	-	3	V
HIGH-level input voltage	$V_{IH}$	<1	-	5	3.5	-	-	V
		<1	-	10	7	-	-	V
input leakage current	$I_I$	-	-	12	-	-	$\pm 0.3$	$\mu\text{A}$

#### 3.3.2、DC Characteristics 2

( $T_{amb}=-40^{\circ}\text{C}$  to  $+85^{\circ}\text{C}$ , voltages are referenced to  $V_{SS}$  (ground=0V), unless otherwise specified.)

Parameter	Symbol	Conditions			$T_{amb}=-40^{\circ}\text{C}$		$T_{amb}=+85^{\circ}\text{C}$		Unit
		$ I_O (\mu\text{A})$	$V_O(\text{V})$	$V_{DD}(\text{V})$	Min.	Max.	Min.	Max.	
supply current	$I_{DD}$	0	-	5	-	20	-	150	$\mu\text{A}$
		0	-	10	-	40	-	300	$\mu\text{A}$
LOW-level output current	$I_{OL}$	-	0.4	5	0.52	-	0.36	-	$\text{mA}$
		-	0.5	10	1.3	-	0.9	-	$\text{mA}$
HIGH-level output current	$I_{OH}$	-	2.5	5	-	-1.7	-	-1.1	$\text{mA}$
		-	4.6	5	-	-0.52	-	-0.36	$\text{mA}$
		-	9.5	10	-	-1.3	-	-0.9	$\text{mA}$
LOW-level output voltage	$V_{OL}$	<1	-	5	-	0.05	-	0.05	V
		<1	-	10	-	0.05	-	0.05	V
HIGH-level output voltage	$V_{OH}$	<1	-	5	4.95	-	4.95	-	V
		<1	-	10	9.95	-	9.95	-	V
LOW-level input voltage	$V_{IL}$	<1	-	5	-	1.5	-	1.5	V
		<1	-	10	-	3	-	3	V
HIGH-level input voltage	$V_{IH}$	<1	-	5	3.5	-	3.5	-	V
		<1	-	10	7	-	7	-	V
input leakage current	$I_I$	-	-	12	-	$\pm 0.3$	-	$\pm 1.0$	$\mu\text{A}$



### 3.3.3. AC Characteristics

( $T_{amb}=25^{\circ}C$ ,  $V_{SS}=0V$ , unless otherwise specified.)

Parameter	Symbol	Conditions	Min.	Typ.	Max.	Unit	
HIGH to LOW propagation delay	$t_{PHL}$	$\bar{n}A$ or $\bar{n}B$ to $\bar{n}Q$ ; see Figure 5	$V_{DD}=5V$	-	140	280	ns
			$V_{DD}=10V$	-	50	100	ns
		$\bar{n}CD$ to $\bar{n}Q$ ; see Figure 5	$V_{DD}=5V$	-	105	210	ns
			$V_{DD}=10V$	-	40	85	ns
LOW to HIGH propagation delay	$t_{PLH}$	$\bar{n}A$ or $\bar{n}B$ to $\bar{n}Q$ ; see Figure 5	$V_{DD}=5V$	-	155	305	ns
			$V_{DD}=10V$	-	60	115	ns
		$\bar{n}CD$ to $\bar{n}Q$ ; see Figure 5	$V_{DD}=5V$	-	120	240	ns
			$V_{DD}=10V$	-	50	105	ns
transition time	$t_t$	$\bar{n}Q$ , $\bar{n}Q$ ; see Figure 5	$V_{DD}=5V$	-	60	120	ns
			$V_{DD}=10V$	-	30	60	ns
recovery time	$t_{rec}$	$\bar{n}CD$ to $\bar{n}A$ or $\bar{n}B$ ; see Figure 6	$V_{DD}=5V$	0	-75	-	ns
			$V_{DD}=10V$	0	-30	-	ns
set-up time	$t_{su}$	$\bar{n}CD$ to $\bar{n}A$ or $\bar{n}B$ ; see Figure 6	$V_{DD}=5V$	0	-105	-	ns
			$V_{DD}=10V$	0	-40	-	ns
pulse width	$t_w$	$\bar{n}A$ LOW; minimum width; see Figure 6	$V_{DD}=5V$	50	25	-	ns
			$V_{DD}=10V$	30	15	-	ns
		$\bar{n}B$ HIGH; minimum width; see Figure 6	$V_{DD}=5V$	50	25	-	ns
			$V_{DD}=10V$	30	15	-	ns
		$\bar{n}CD$ LOW; minimum width; see Figure 6	$V_{DD}=5V$	60	30	-	ns
			$V_{DD}=10V$	35	15	-	ns
		$\bar{n}Q$ or $\bar{n}Q$ ; $R_{EXT}=5k\Omega$ ; $C_{EXT}=15pF$ ; see Figure 6	$V_{DD}=5V$	-	235	-	ns
			$V_{DD}=10V$	-	155	-	ns
$\bar{n}Q$ or $\bar{n}Q$ ; $R_{EXT}=10k\Omega$ ; $C_{EXT}=1nF$ ; see Figure 6	$V_{DD}=5V$	-	5.45	-	us		
	$V_{DD}=10V$	-	4.95	-	us		
pulse width variation	$\Delta t_w$	nQ output variation over temperature range	$V_{DD}=5V$	-	$\pm 3$	-	%
			$V_{DD}=10V$	-	$\pm 2$	-	%
		nQ output variation over voltage range $V_{DD} \pm 5\%$	$V_{DD}=5V$	-	$\pm 2$	-	%
			$V_{DD}=10V$	-	$\pm 1$	-	%
external timing resistor	$R_{EXT}$	see Figure 4	$V_{DD}=5V$	5	-	2	M $\Omega$
			$V_{DD}=10V$	5	-	2	M $\Omega$
external timing capacitor	$C_{EXT}$	see Figure 4	$V_{DD}=5V$	no limits		-	
			$V_{DD}=10V$	no limits		-	
input capacitance	$C_i$	-	-	-	7.5	pF	

Note:

[1]  $t_t$  is the same as  $t_{TLH}$  and  $t_{THL}$ .

[2] For other  $R_{EXT}$ ,  $C_{EXT}$  combinations and  $C_{EXT}<0.01\mu F$ , see Figure 4.

[3] For other  $R_{EXT}$ ,  $C_{EXT}$  combinations and  $C_{EXT}>0.01\mu F$ , use formula  $t_w=K \times R_{EXT} \times C_{EXT}$ .





where:  $t_w$ =output pulse width (s);

$R_{EXT}$ =external timing resistor ( $\Omega$ );

$C_{EXT}$ =external timing capacitor (F);

$K=0.42$  for  $V_{DD}=5V$ ;

$K=0.32$  for  $V_{DD}=10V$ ;

$K=0.30$  for  $V_{DD}=15V$ .

[4]  $T_{amb}=-40^{\circ}C$  to  $+85^{\circ}C$ ;  $\Delta t_w$  is referenced to  $t_w$  at  $T_{amb}=25^{\circ}C$ .

## 4、 Testing Circuit

### 4.1、 AC Testing Circuit

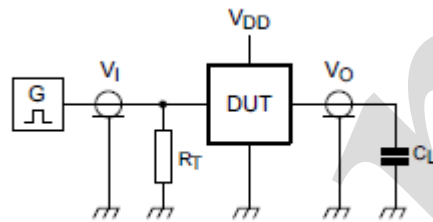

Figure 3. Test circuit for switching times

Definitions for test circuit:

DUT=Device Under Test.

$C_L$ =Load capacitance including jig and probe capacitance.

$R_T$ =Termination resistance should be equal to the output impedance  $Z_o$  of the pulse generator.

### 4.2、 AC Testing Waveforms

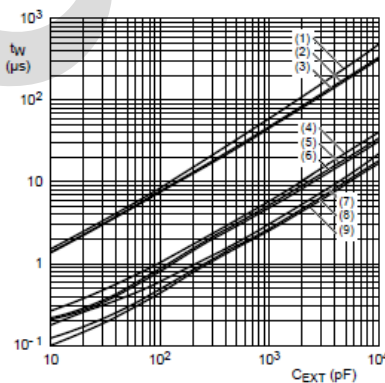

- (1)  $R_{EXT} = 100\text{ k}\Omega$ ,  $V_{DD} = 5\text{ V}$ .
- (2)  $R_{EXT} = 100\text{ k}\Omega$ ,  $V_{DD} = 10\text{ V}$ .
- (3)  $R_{EXT} = 100\text{ k}\Omega$ ,  $V_{DD} = 15\text{ V}$ .
- (4)  $R_{EXT} = 10\text{ k}\Omega$ ,  $V_{DD} = 5\text{ V}$ .
- (5)  $R_{EXT} = 10\text{ k}\Omega$ ,  $V_{DD} = 10\text{ V}$ .
- (6)  $R_{EXT} = 10\text{ k}\Omega$ ,  $V_{DD} = 15\text{ V}$ .
- (7)  $R_{EXT} = 5\text{ k}\Omega$ ,  $V_{DD} = 5\text{ V}$ .
- (8)  $R_{EXT} = 5\text{ k}\Omega$ ,  $V_{DD} = 10\text{ V}$ .
- (9)  $R_{EXT} = 5\text{ k}\Omega$ ,  $V_{DD} = 15\text{ V}$ .

Figure 4. Output pulse width ( $t_w$ ) as a function of external timing capacitor ( $C_{EXT}$ )

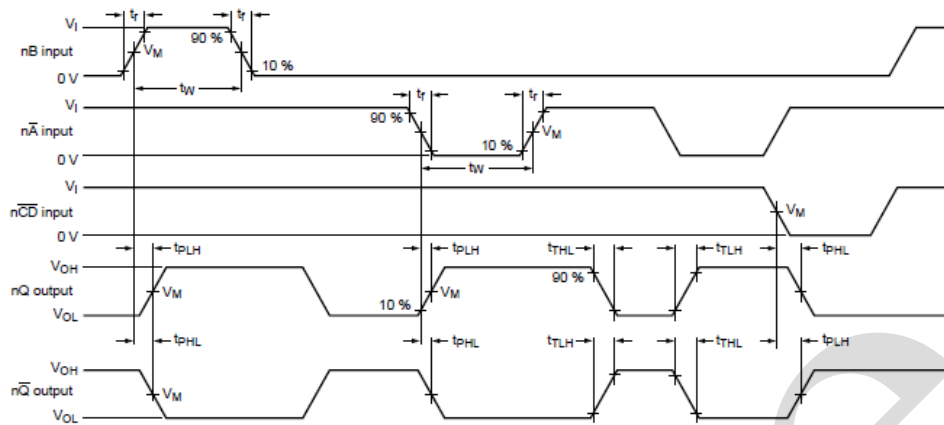

Figure 5. Waveforms showing propagation delays and transition times

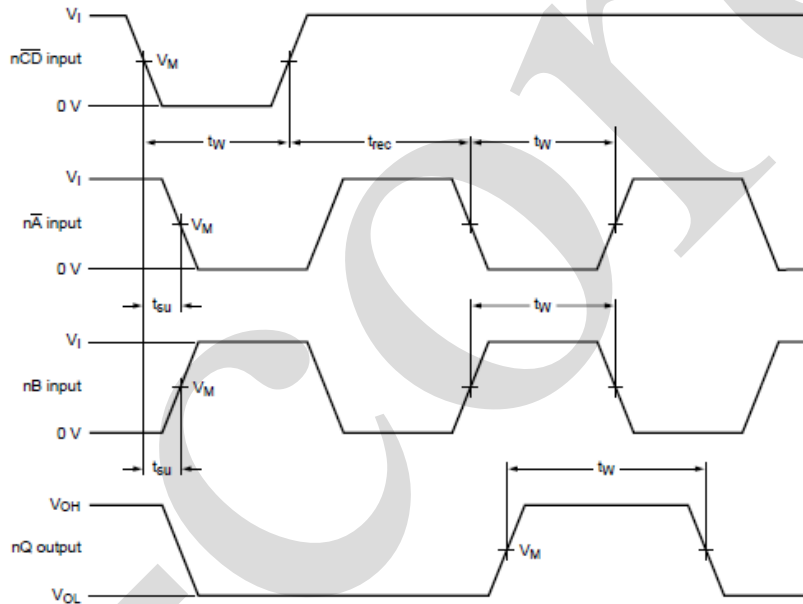

Figure 6. Waveforms showing minimum nA, nB, and nQ pulse widths and set-up and recovery times

4.3、 Measurement Points

Supply voltage	Input	Output
$V_{DD}$	$V_M$	$V_M$
5V to 12V	$0.5 \times V_{DD}$	$0.5 \times V_{DD}$

4.4、 Test Data

Supply voltage	Input		Load
$V_{DD}$	$V_I$	$t_r, t_f$	$C_L$
5V to 12V	$V_{SS}$ or $V_{DD}$	$\leq 20ns$	50pF



## 5、 Package Information

### 5.1、 DIP16

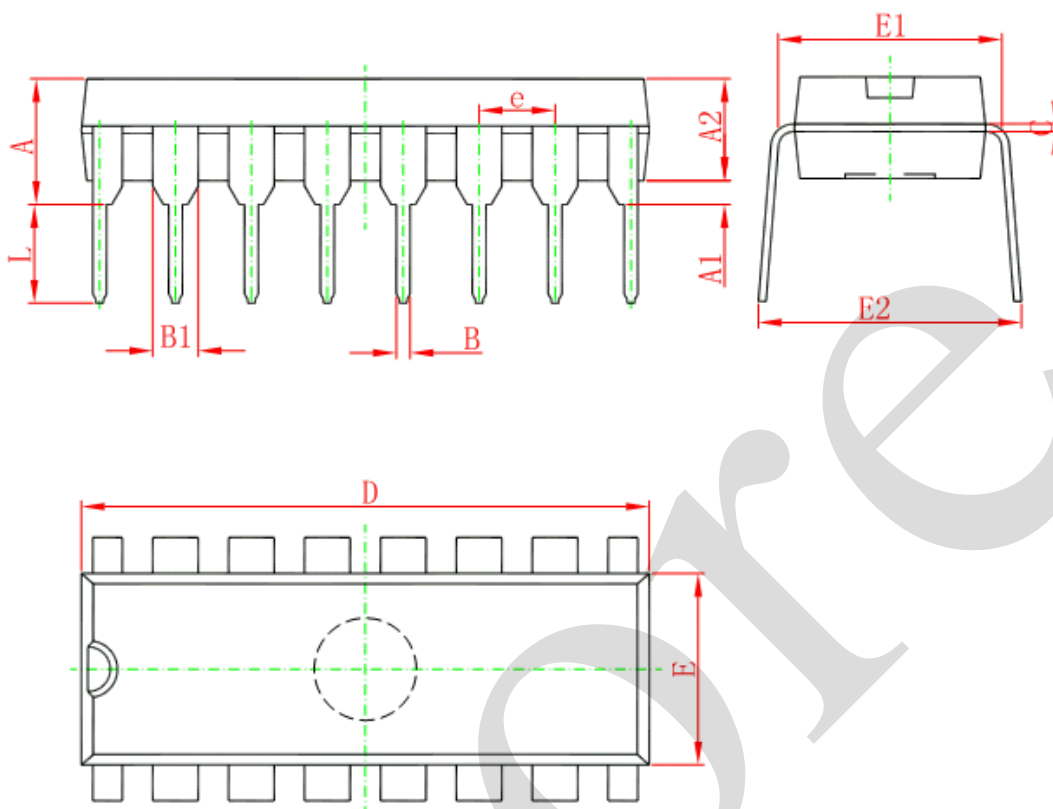

Symbol	Dimensions In Millimeters		Dimensions In Inches	
	Min	Max	Min	Max
A	3.710	4.310	0.146	0.170
A1	0.510		0.020	
A2	3.200	3.600	0.126	0.142
B	0.380	0.570	0.015	0.022
B1	1.524 (BSC)		0.060 (BSC)	
C	0.204	0.360	0.008	0.014
D	18.800	19.200	0.740	0.756
E	6.200	6.600	0.244	0.260
E1	7.320	7.920	0.288	0.312
e	2.540 (BSC)		0.100 (BSC)	
L	3.000	3.600	0.118	0.142
E2	8.400	9.000	0.331	0.354



## 5.2、SOP16

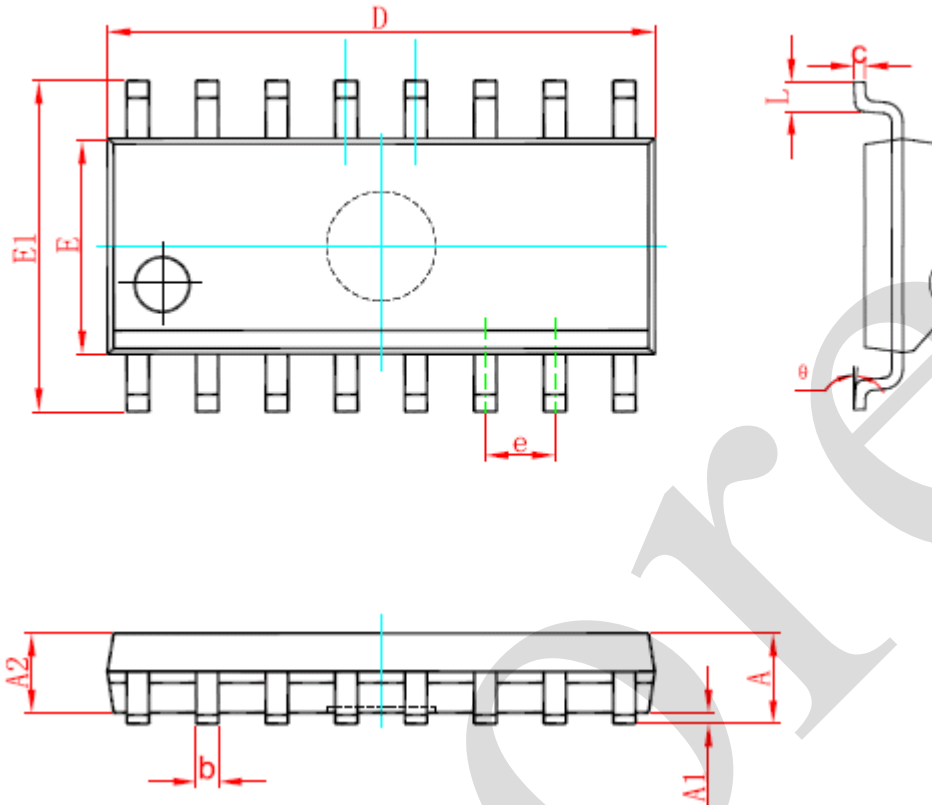

Symbol	Dimensions In Millimeters		Dimensions In Inches	
	Min	Max	Min	Max
A	1.350	1.750	0.053	0.069
A1	0.100	0.250	0.004	0.010
A2	1.350	1.550	0.053	0.061
b	0.330	0.510	0.013	0.020
c	0.170	0.250	0.007	0.010
D	9.800	10.200	0.386	0.402
E	3.800	4.000	0.150	0.157
E1	5.800	6.200	0.228	0.244
e	1.270 (BSC)		0.050 (BSC)	
L	0.400	1.270	0.016	0.050
θ	0°	8°	0°	8°



## 5.3、TSSOP16

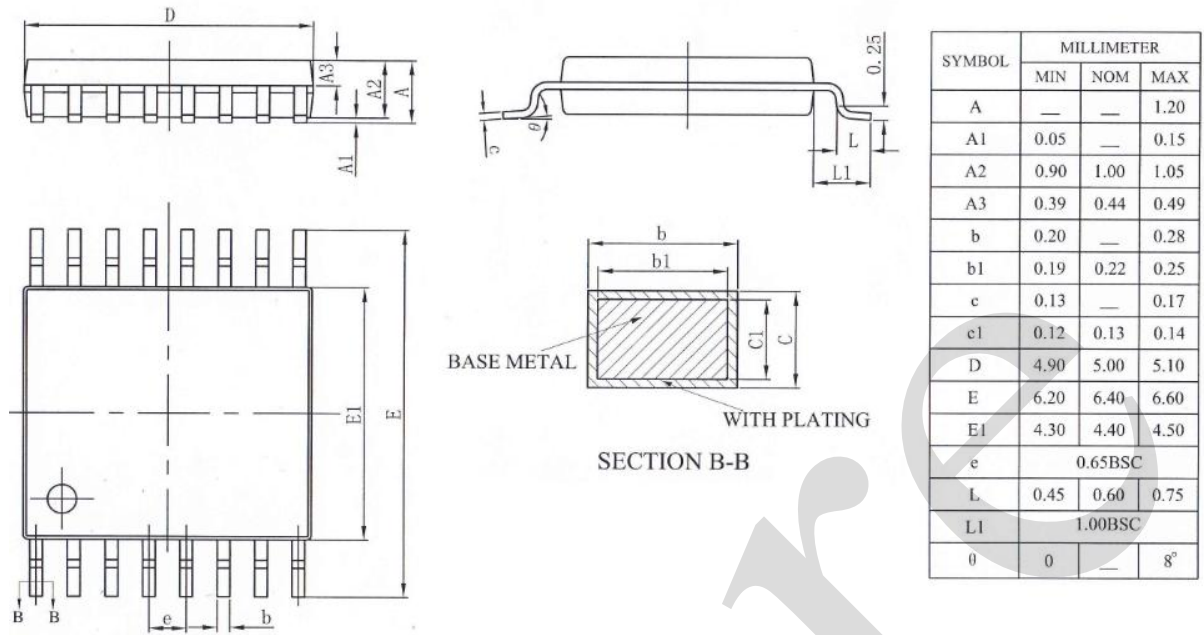



## 6、 Statements And Notes

### 6.1、 The name and content of Hazardous substances or Elements in the product

Part name	Hazardous substances or Elements									
	Lead and lead compounds	Mercury and mercury compounds	Cadmium and cadmium compounds	Hexavalent chromium compounds	Polybrominated biphenyls	Polybrominated biphenyl ethers	Dibutyl phthalate	Butylbenzyl phthalate	Di-2-ethylhexyl phthalate	Diisobutyl phthalate
Lead frame	○	○	○	○	○	○	○	○	○	○
Plastic resin	○	○	○	○	○	○	○	○	○	○
Chip	○	○	○	○	○	○	○	○	○	○
The lead	○	○	○	○	○	○	○	○	○	○
Plastic sheet installed	○	○	○	○	○	○	○	○	○	○
explanation	○: Indicates that the content of hazardous substances or elements in the detection limit of the following the SJ/T11363-2006 standard. ×: Indicates that the content of hazardous substances or elements exceeding the SJ/T11363-2006 Standard limit requirements.									

### 6.2、 Notion

Recommended carefully reading this information before the use of this product;

The information in this document are subject to change without notice;

This information is using to the reference only, the company is not responsible for any loss;

The company is not responsible for the any infringement of the third party patents or other rights of the responsibility.

## X-ON Electronics

Largest Supplier of Electrical and Electronic Components

*Click to view similar products for [Flip-Flops category](#):*

*Click to view products by [I-core manufacturer](#):*

Other Similar products are found below :

[NLV74HC74ADTR2G](#) [74F574SC](#) [TC7W74FUTE12LF](#) [NLV14013BDR2G](#) [NLV74HC74ADR2G](#) [MC10EP131MNG](#) [MC74AC74DTR2](#)  
[74VHC574FT\(BJ\)](#) [HT4093ARZ](#) [SN74HC374ANSR](#) [CD4528BE](#) [CD4027BE](#) [RS74HC74XQ](#) [RS574XTSS20](#) [74HCT273PW-Q100J](#)  
[SN74ABT273PWRE4](#) [CLVC2G74QDCURG4Q1](#) [CD4067TA24.TB](#) [CD4013SA.TR](#) [AIP74HCT14TA14.TB](#) [HSN74LVC1G14DBVR](#)  
[CD4013BPWRG](#) [AiP74LVC74TA14.TB](#) [CD4013BDRG](#) [CD4528SA16.TR](#) [AIP74HC273SA.TB](#) [SN74HCS74QDYRQ1](#) [CD4013TA14.TB](#)  
[SN74LS107N](#) [SN74LS374DWR](#) [SN74LVC2G14DC\(LX\)](#) [MC74HC73ADG](#) [MC74HC73ADR2G](#) [74LCX16374MTDX](#) [74LVT74D,118](#)  
[74VHCT9273FT\(BJ\)](#) [MM74HC374WM](#) [MM74HC74AMX](#) [74ALVCH162374PAG](#) [74LVC1G175GS,132](#) [74LVX74MTCX](#)  
[TC7WZ74FK,LJ\(CT\)](#) [MM74HCT273WM](#) [SN74LVC74AD](#) [SN74HC273DWR](#) [M74HC374RM13TR](#) [M74HC175B1R](#) [M74HC174RM13TR](#)  
[74ALVTH32374ZKER](#) [74AUP1G74DC,125](#)