

这些比较器设计用于电平检测、低电平传感和在消费汽车领域的存储应用和工业中的电子应用

- 单电源或分电源操作
- 低输入偏置电流 25 nA (Typ)
- 低输入失调电流 ± 5.0 nA (Typ)
- 低输入失调电压 ± 1.0 mV (Typ)
- 共模输入电压范围至接地
- 低输出饱和电压 130 mV (Typ) @ 4.0 mA
- TTL and CMOS 兼容
- 输入端上的 ESD 箝位提高了可靠性，而不影响器件操作

极限值

评级	符号	数值	单位
电源供电电压	V_{CC}	+36 or ± 18 +30 or ± 15	Vdc
输入差分电压范围	V_{IDR}	36 30	Vdc
输入共模电压范围	V_{ICMR}	-0.3 to V_{CC}	Vdc
输出对地短路 (Note 1)	I_{SC}	Continuous	
功耗 @ $T_A = 25^\circ\text{C}$ 塑料封装 Derate above 25°C	P_D	1.0 8.0	W mW/ $^\circ\text{C}$
结温	T_J	150	$^\circ\text{C}$
操作温度范围 LM239, A MC3302 LM2901 LM2901V LM339, A	T_A	-25 to +85 -40 to +85 -40 to +105 -40 to +125 0 to +70	$^\circ\text{C}$
存储温度范围	T_{stg}	-65 to +150	$^\circ\text{C}$

NOTE: 1. 最大输出电流可高达 20 毫安，与 V_{CC} 的大小无关
输出短路到 V_{CC} 可能会导致过度加热和最终破坏

图 1 电路原理图

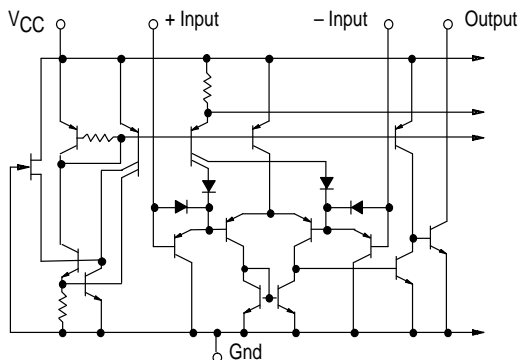

NOTE: 图示为 1 个比较器

实物图

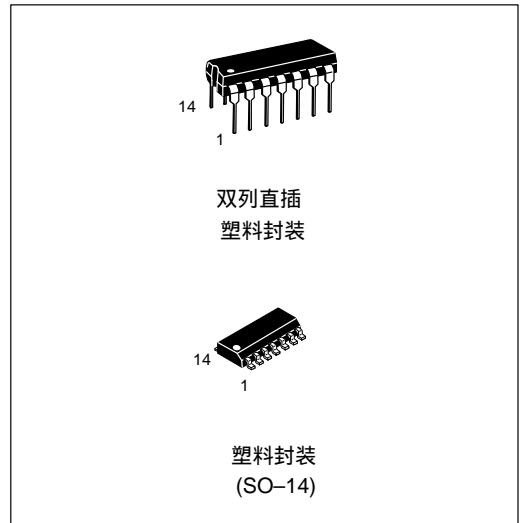

引脚连线

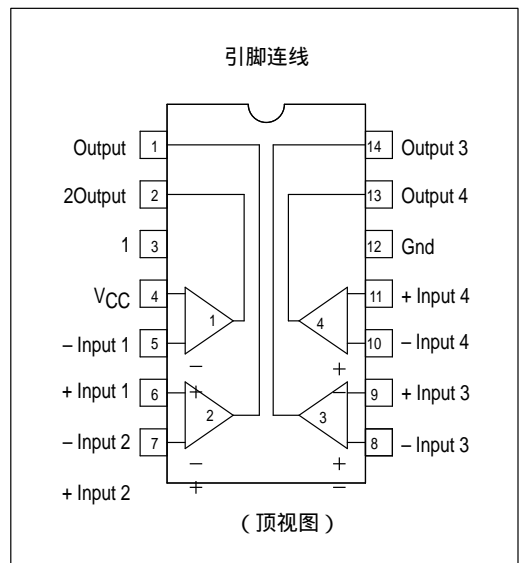

订购须知

器件	操作温度范围	封装
LM239D, AD LM239N, AN	$T_A = 25^\circ$ to $+85^\circ\text{C}$	SO-14 Plastic DIP
LM339D, AD LM339N, AN	$T_A = 0^\circ$ to $+70^\circ\text{C}$	SO-14 Plastic DIP
LM2901D LM2901N	$T_A = -40^\circ$ to $+105^\circ\text{C}$	SO-14 Plastic DIP
LM2901VD LM2901VN	$T_A = -40^\circ$ to $+125^\circ\text{C}$	SO-14 Plastic DIP
MC3302P	$T_A = -40^\circ$ to $+85^\circ\text{C}$	Plastic DIP

LM339S

四路单电源比较器

 电气特性 ($V_{CC} = +5.0 \text{ Vdc}$, $T_A = +25^\circ\text{C}$, 除非另有说明)

特性	字符	LM239A/339A			LM239/339			LM2901/2901V			MC3302			单位
		Min	Typ	Max	Min	Typ	Max	Min	Typ	Max	Min	Typ	Max	
输入失调电压 (Note 4)	V_{IO}	-	± 1.0	± 2.0	-	± 2.0	± 5.0	-	± 2.0	± 7.0	-	± 3.0	± 20	mVdc
输入偏执电压 (Notes 4, 5) (模拟范围输出)	I_{IB}	-	25	250	-	25	250	-	25	250	-	25	500	nA
输入失调电流 (Note 4)	I_{IO}	-	± 5.0	± 50	-	± 5.0	± 50	-	± 5.0	± 50	-	± 3.0	± 100	nA
输入共模电压范围	V_{ICMR}	0	-	$V_{CC} - 1.5$	0	-	$V_{CC} - 1.5$	0	-	$V_{CC} - 1.5$	0	-	$V_{CC} - 1.5$	V
供电电流 $R_L = \infty$ (For All Comparators) $R_L = \infty$, $V_{CC} = 30 \text{ Vdc}$	I_{CC}	-	0.8	2.0	-	0.8	2.0	-	0.8	2.0	-	0.8	2.0	mA
		-	1.0	2.5	-	1.0	2.5	-	1.0	2.5	-	1.0	2.5	
电压增益 $R_L \geq 15 \text{ k}\Omega$, $V_{CC} = 15 \text{ Vdc}$	A_{VOL}	50	200	-	50	200	-	25	100	-	25	100	-	V/mV
大信号响应时间 $V_I = \text{TTL Logic Swing}$, $V_{ref} = 1.4 \text{ Vdc}$, $V_{RL} = 5.0 \text{ Vdc}$, $R_L = 5.1 \text{ k}\Omega$	-	-	300	-	-	300	-	-	300	-	-	300	-	ns
响应时间 (Note 6) $V_{RL} = 5.0 \text{ Vdc}$, $R_L = 5.1 \text{ k}\Omega$	-	-	1.3	-	-	1.3	-	-	1.3	-	-	1.3	-	μs
输出吸收电流 $V_I(-) \geq +1.0 \text{ Vdc}$, $V_I(+)=0$, $V_O \leq 1.5 \text{ Vdc}$	I_{Sink}	6.0	16	-	6.0	16	-	6.0	16	-	6.0	16	-	mA
饱和电压 $V_I(-) \geq +1.0 \text{ Vdc}$, $V_I(+)=0$, $I_{sink} \leq 4.0 \text{ mA}$	V_{sat}	-	130	400	-	130	400	-	130	400	-	130	500	mV
输出漏电流 $V_I(+)\geq +1.0 \text{ Vdc}$, $V_I(-)=0$, $V_O = +5.0 \text{ Vdc}$	I_{OL}	-	0.1	-	-	0.1	-	-	0.1	-	-	0.1	-	nA

 运行特性 ($V_{CC} = +5.0 \text{ Vdc}$, $T_A = T_{low}$ to T_{high} [Note 3])

特性	字符	LM239A/339A			LM239/339			LM2901/2901V			MC3302			Unit
		Min	Typ	Max	Min	Typ	Max	Min	Typ	Max	Min	Typ	Max	
输入失调电压 (Note 4)	V_{IO}	-	-	± 4.0	-	-	± 9.0	-	-	± 15	-	-	± 40	mVdc
输入偏执电压 (Notes 4, 5) (模拟输出范围)	I_{IB}	-	-	400	-	-	400	-	-	500	-	-	1000	nA
输入失调电流 (Note 4)	I_{IO}	-	-	± 150	-	-	± 150	-	-	± 200	-	-	± 300	nA
输入共模电压范围	V_{ICMR}	0	-	$V_{CC} - 2.0$	0	-	$V_{CC} - 2.0$	0	-	$V_{CC} - 2.0$	0	-	$V_{CC} - 2.0$	V
饱和电压 $V_I(-) \geq +1.0 \text{ Vdc}$, $V_I(+)=0$, $I_{sink} \leq 4.0 \text{ mA}$	V_{sat}	-	-	700	-	-	700	-	-	700	-	-	700	mV
输出漏电流 $V_I(+)\geq +1.0 \text{ Vdc}$, $V_I(-)=0$, $V_O = 30 \text{ Vdc}$	I_{OL}	-	-	1.0	-	-	1.0	-	-	1.0	-	-	1.0	μA
差分输入电压 All $V_I \geq 0 \text{ Vdc}$	V_{ID}	-	-	V_{CC}	-	-	V_{CC}	-	-	V_{CC}	-	-	V_{CC}	Vdc

NOTES: 3. (LM239/239A) $T_{low} = -25^\circ\text{C}$, $T_{high} = +85^\circ\text{C}$
 (LM339/339A) $T_{low} = 0^\circ\text{C}$, $T_{high} = +70^\circ\text{C}$
 (MC3302) $T_{low} = -40^\circ\text{C}$, $T_{high} = +85^\circ\text{C}$
 (LM2901) $T_{low} = -40^\circ\text{C}$, $T_{high} = +105^\circ\text{C}$
 (LM2901V) $T_{low} = -40^\circ\text{C}$, $T_{high} = +125^\circ\text{C}$

4. 在输出开关点 $V_O = 1.4 \text{ Vdc}$, $R_S \leq 100 \Omega$, $5.0 \text{ Vdc} \leq V_{CC} \leq 30 \text{ Vdc}$, with the inputs over the full common mode range (0 Vdc to $V_{CC} - 1.5 \text{ Vdc}$).

5. 偏置电流由于 PNP 输入级而流出输入。该电流实际上是恒定的, 与输出状态无关

6. 指定的响应时间用于具有 5 . 0 mV 过驱动的 1 0 0 mV 输入步骤。对于较大的信号, 典型的是 3 0 0 n s

图2 .反相滞后比较器

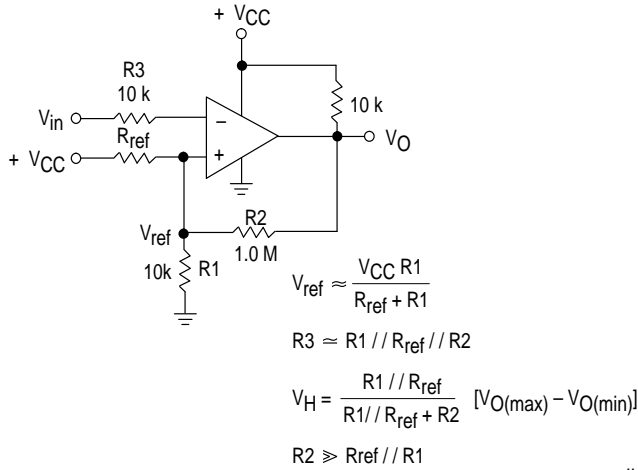

典型特征

(V_{CC} = 15 Vdc, T_A = +25°C (each comparator) unless otherwise noted.)

图3 .同相滞后比较器



图4 .归一化的输入失调电压



图5 . 输入偏执电流

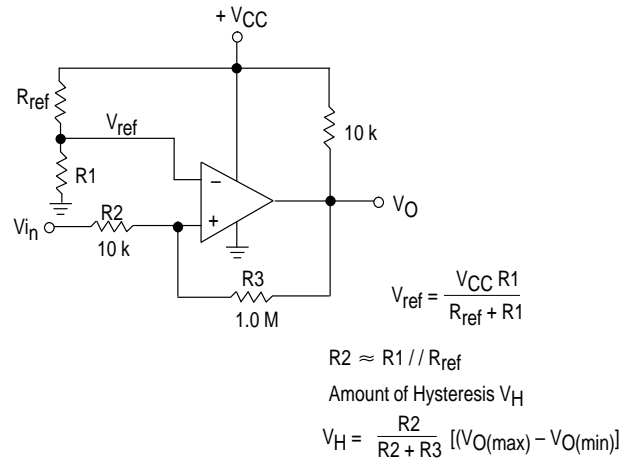

图6 . 输出吸收电流
输出饱和电压

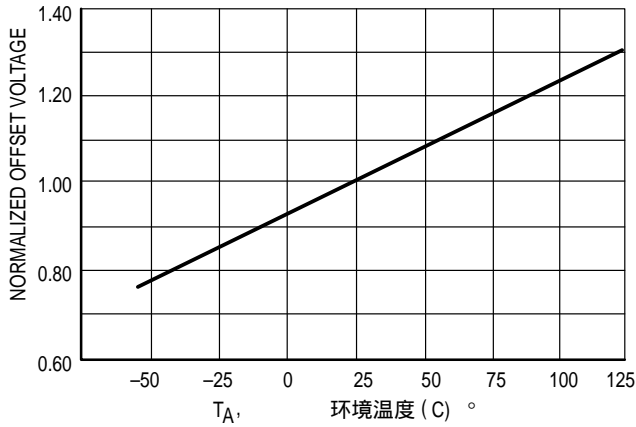

图 6 : 驱动逻辑

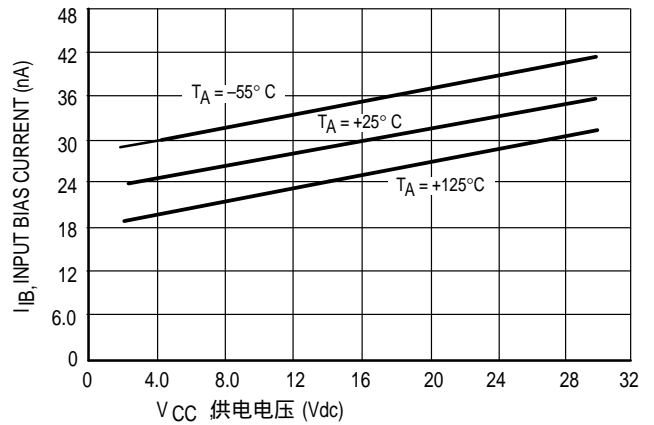

R_S = Source Resistance
 $R_1 \approx R_S$

Logic	Device	VCC (V)	RL kΩ
CMOS	1/4 MC14001	+15	100
TTL	1/4 MC7400	+5.0	10

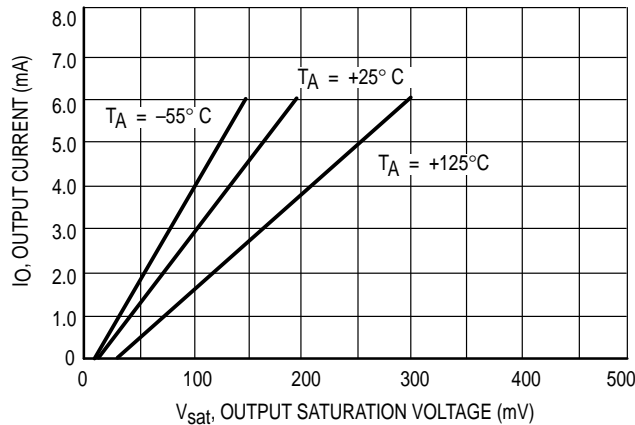
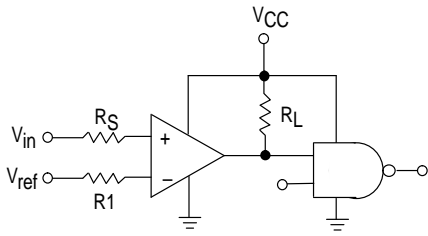
These quad comparators feature high gain, wide bandwidth characteristics. This gives the device oscillation tendencies if the outputs are capacitively coupled to the inputs via stray capacitance. This oscillation manifests itself during output transitions (V_{OL} to V_{OH}). To alleviate this situation input resistors $< 10\text{ k}\Omega$ should be used. The addition

图 7 : 方波振荡器

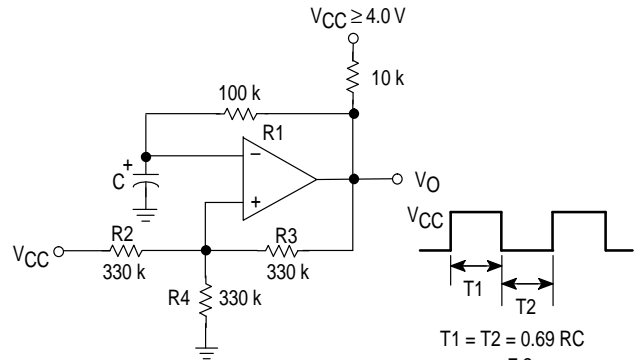

$T_1 = T_2 = 0.69 RC$

$f \approx \frac{7.2}{C(\mu F)}$

$R_2 = R_3 = R_4$

$R_1 \approx R_2 // R_3 // R_4$

应用信息

of positive feedback ($< 10\text{ mV}$) is also recommended. It is good design practice to ground all unused input pins.

Differential input voltages may be larger than supply voltages without damaging the comparator's inputs. Voltages more negative than -300 mV should not be used.

图 9 : 过零检测器 (Single Supply)

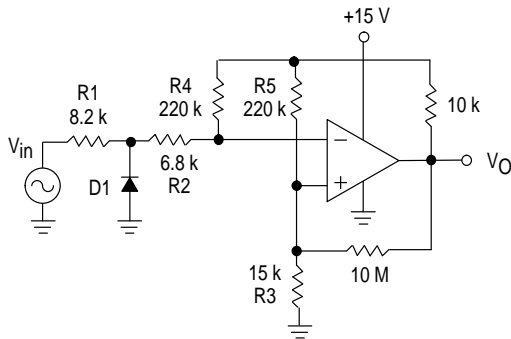

D1 prevents input from going negative by more than 0.6 V.

$R_1 + R_2 = R_3$

$R_3 \leq \frac{R_5}{10}$ for small error in zero crossing

图 10 : 过零检测器 (Split Supplies)

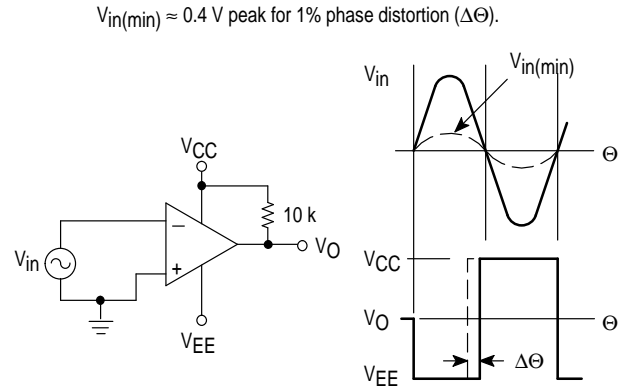

$V_{in(min)} \approx 0.4\text{ V peak for } 1\% \text{ phase distortion } (\Delta\Theta).$

外形尺寸：

N, P SUFFIX
PLASTIC PACKAGE
CASE 646-06
ISSUE L

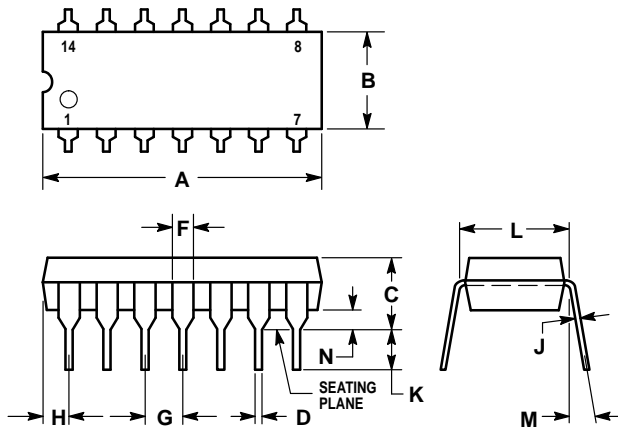

NOTES:

- LEADS WITHIN 0.13 (0.005) RADIUS OF TRUE POSITION AT SEATING PLANE AT MAXIMUM MATERIAL CONDITION.
- DIMENSION L TO CENTER OF LEADS WHEN FORMED PARALLEL.
- DIMENSION B DOES NOT INCLUDE MOLD FLASH.
- ROUNDED CORNERS OPTIONAL.

DIM	INCHES		MILLIMETERS	
	MIN	MAX	MIN	MAX
A	0.715	0.770	18.16	19.56
B	0.240	0.260	6.10	6.60
C	0.145	0.185	3.69	4.69
D	0.015	0.021	0.38	0.53
F	0.040	0.070	1.02	1.78
G	0.100 BSC		2.54 BSC	
H	0.052	0.095	1.32	2.41
J	0.008	0.015	0.20	0.38
K	0.115	0.135	2.92	3.43
L	0.300 BSC		7.62 BSC	
M	0°	10°	0°	10°
N	0.015	0.039	0.39	1.01

D SUFFIX
PLASTIC PACKAGE
CASE 751A-03
(SO-14)
ISSUE F

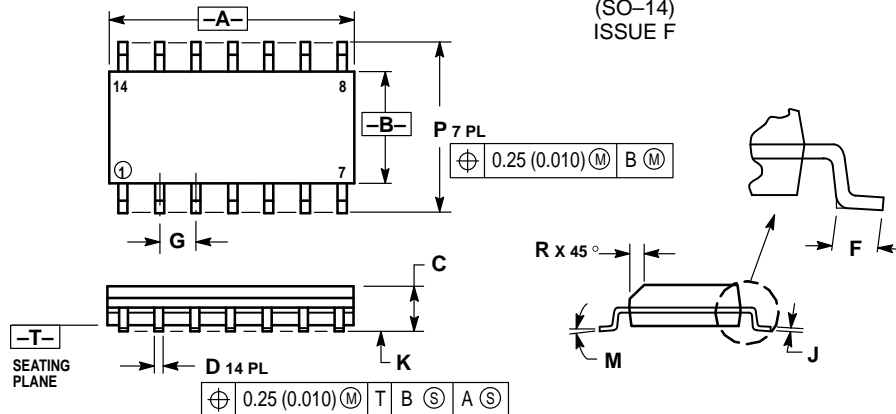

NOTES:

- DIMENSIONING AND TOLERANCING PER ANSI Y14.5M, 1982.
- CONTROLLING DIMENSION: MILLIMETER.
- DIMENSIONS A AND B DO NOT INCLUDE MOLD PROTRUSION.
- MAXIMUM MOLD PROTRUSION 0.15 (0.006) PER SIDE.
- DIMENSION D DOES NOT INCLUDE DAMBAR PROTRUSION. ALLOWABLE DAMBAR PROTRUSION SHALL BE 0.127 (0.005) TOTAL IN EXCESS OF THE D DIMENSION AT MAXIMUM MATERIAL CONDITION.

DIM	MILLIMETERS		INCHES	
	MIN	MAX	MIN	MAX
A	8.55	8.75	0.337	0.344
B	3.80	4.00	0.150	0.157
C	1.35	1.75	0.054	0.068
D	0.35	0.49	0.014	0.019
F	0.40	1.25	0.016	0.049
G	1.27 BSC		0.050 BSC	
J	0.19	0.25	0.008	0.009
K	0.10	0.25	0.004	0.009
M	0°	7°	0°	7°
P	5.80	6.20	0.228	0.244
R	0.25	0.50	0.010	0.019

X-ON Electronics

Largest Supplier of Electrical and Electronic Components

Click to view similar products for [Operational Amplifiers - Op Amps](#) category:

Click to view products by [IDCHIP](#) manufacturer:

Other Similar products are found below :

[430227FB](#) [UPC451G2-A](#) [UPC824G2-A](#) [LT1678IS8](#) [UPC258G2-A](#) [NCV33202DMR2G](#) [NJM324E](#) [NTE925](#) [AZV358MTR-G1](#)
[AP4310AUMTR-AG1](#) [AZV358MMTR-G1](#) [SCY33178DR2G](#) [NCV5652MUTWG](#) [NCV20034DR2G](#) [NTE778S](#) [NTE871](#) [NTE937](#)
[MCP6V16UT-E/OT](#) [SCY6358ADR2G](#) [UPC4570G2-E1-A](#) [NCS20282FCTTAG](#) [UPC834G2-E1-A](#) [UPC1458G2-E2-A](#) [UPC813G2-E2-A](#)
[UPC458G2-E1-A](#) [UPC824G2-E2-A](#) [UPC4574G2-E2-A](#) [UPC4558G2-E2-A](#) [UPC4560G2-E1-A](#) [UPC258G2-E1-A](#) [UPC4742GR-9LG-E1-A](#)
[UPC4742G2-E1-A](#) [UPC832G2-E2-A](#) [UPC842G2-E1-A](#) [UPC802G2-E1-A](#) [UPC4741G2-E2-A](#) [UPC4572G2-E2-A](#) [UPC844GR-9LG-E2-A](#)
[UPC259G2-E1-A](#) [UPC4741G2-E1-A](#) [UPC4558G2-E1-A](#) [UPC1251GR-9LG-E1-A](#) [UPC4744G2-E1-A](#) [UPC4092G2-E1-A](#) [UPC4574G2-E1-A](#)
[UPC4062G2-E2-A](#) [UPC451G2-E2-A](#) [UPC832G2-E1-A](#) [UPC844GR-9LG-E1-A](#) [UPC4744G2-E2-A](#)