



PLC High Density Analog I/O Module

- Features**
- 8-pt (0-10V DC / 4-20mA) input module
 - 2-pt (-10 to +10VDC / 4-20mA) output module
 - 16-bit Resolution
 - Fast Conversion Times
 - Configure up to 56 analog I/Os



Specifications

General Specifications		
Part Number	FC4A-J8C1	FC4A-K2C1
Rated Power Voltage	24V DC	
Allowable Voltage Range	20.4 to 28.8V DC	
Terminal Arrangement	See Analog I/O Module User's Manual -pages 2-8 to 2-11	
Connector on Mother Board	MC1.5/10-G-3.81BK (Phoenix Contact)	
Connector Insertion/Removal Durability	100 times minimum	
Internal Current Draw	40mA (5V DC)	60mA (5V DC)
	0mA (24V DC)	0mA (24V DC)
External Current Draw (Note)	50mA (24V DC)	85mA (24V DC)
Weight	140g	110g

Analog Input Specifications		
Part Number	FC4A-J8C1	
Analog Input Signal Type	Voltage Input	Current Input
Input Range	0 to 10V DC	4 to 20mA
Input Impedance	1 MΩ	100Ω
AD Conversion	Sample Duration Time	2ms maximum
	Sample Repetition Time	2ms maximum
	Total Input System Transfer Time ^{Note 1}	8ms x channels + 1 scan time
	Type of Input	Single-ended input
	Operating Mode	Self-scan
Input Error	Conversion Method	Successive approximation register method
	Maximum Error at 25°C	±0.2% of full scale
	Temperature Coefficient	±0.005% of full scale / °C
	Repeatability after Stabilization Time	±0.5% of full scale
	Non-linearity	±0.04% of full scale
	Maximum Error	±1% of full scale



For more information on these and other IDEC PLCs, visit:

www.idec.com/PLC

Analog Output Specifications			
Part Number	FC4A-K2C1		
Output Range	Voltage	-10 to +10V DC	
	Current	4 to 20mA DC	
Load	Load Impedance	2 kΩ minimum (voltage), 300Ω maximum (current)	
	Applicable Load Type	Resistive load	
DA Conversion	Settling Time	1ms / ch	
	Total Output System Transfer Time	1ms x channels + 1 scan time	
Output Error	Maximum Error at 25°C	±0.2% of full scale	
	Temperature Coefficient	±0.005% of full scale/°C	
	Repeatability after Stabilization Time	±0.5% of full scale	
	Output Voltage Drop	±1% of full scale	
	Non-linearity	±0.2% of full scale	
	Output Ripple	±0.1% of full scale	
	Overshoot	0%	
Data	Total Error	±1% of full scale	
	Digital Resolution	50000 increments (16 bits)	
	Output Value of LSB	Voltage	0.4mV
		Current	0.32μA
	Data Type in Application Program	-25000 to 25000 (voltage) 0 to 50000 (current) Optional: -32768 to 32767 (selectable for each channel) ^{Note 2}	
	Monotonicity	Yes	

Specifications con't

Analog Input Specifications		
Data	Digital Resolution	50000 increments (16 bits)
	Input Value of LSB	0.2mV 0.32μA
	Data Type in Application Program	Default: 0 to 50000
	Monotonicity	Optional: -32768 to 32767 (selectable for each channel) ^{Note 2}
	Input Data Out of Range	Detectable ^{Note 3}
Noise Resistance	Maximum Temporary Deviation during Electrical Noise Tests ^{Note 4}	±3% maximum
	Input Filter	Software
	Recommended Cable for Noise Immunity	Twisted pair cable
	Crosstalk	2 LSB maximum
Isolation		Isolated between input and power circuit
		Photocoupler-isolated between input and internal circuit
Effect of Improper Input Connection	No damage	
Maximum Permanent Allowed Overload (No Damage)	11V DC	22 mA DC
Selection of Analog Input Signal Type	Using software programming	

Analog Output Specifications		
Current Loop Open		Not detectable
Noise Resistance	Maximum Temporary Deviation during Electrical Noise Tests ^{Note 4}	±3% maximum
	Recommended Cable for Noise Immunity	Twisted pair cable
	Crosstalk	2 LSB maximum
Isolation		Isolated between output and power circuit
		Photocoupler-isolated between output and internal circuit
Effect of Improper Output Connection	No damage	
Selection of Analog Output Signal Type	Using software programming	

Mounting Hole Layout (mm)

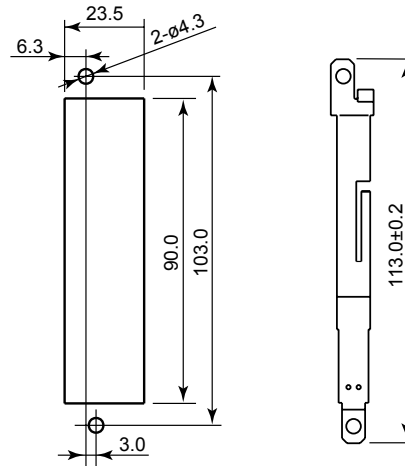

Notes:

1. Total input system transfer time = Sample repetition time + Internal processing time. The total input system transfer time increases in proportion to the number of channels used.
2. The data processed in the analog I/O module can be linear-converted to a value between -32768 and 32767. The optional range designation, and analog I/O data minimum and maximum values can be selected using data registers allocated to analog I/O modules.
3. When an error is detected, a corresponding error code is stored to a data register allocated to analog I/O operating status.
4. The value is measured when a 500V clamp voltage is applied to the power supply and I/O lines.

Dimensions (mm)

FC4A-K2C1

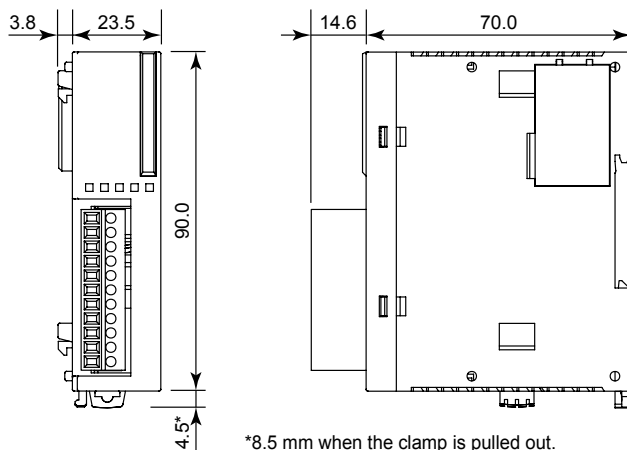

FC4A-J8C1

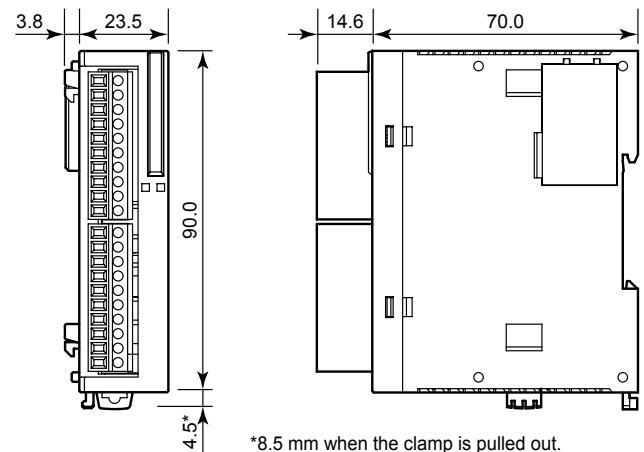

X-ON Electronics

Largest Supplier of Electrical and Electronic Components

Click to view similar products for [I/O Modules](#) category:

Click to view products by [Idec](#) manufacturer:

Other Similar products are found below :

[70L-IDC5S](#) [70L-OAC-L](#) [70Z3289-4](#) [G21960000700](#) [G21960002700](#) [G34960002700](#) [G88104401](#) [GUR02](#) [OACU](#) [C4SWOUT](#) [PB16H](#) [SM-IDC15](#) [G34960001700](#) [G77-S](#) [G78-16-E](#) [GP34829091724](#) [JQP4](#) [ODC-24A](#) [IDC5P](#) [FC6A-N16B1](#) [6421](#) [FC6A-N32B3](#) [70MRCQ32-HL](#) [C200H-LK201-V1](#) [G3TA-OA202SZ-US](#) [DC12](#) [GT1-OD16](#) [GT1-AD04CST](#) [ADAM-5060-AE](#) [GT1-DA04](#) [B7AM-6BS](#) [GRT1-ML2](#) [GRT1-TS2P](#) [CRT1-ID16TAH-1](#) [70GRCQ24-HS](#) [CRT1-ID08](#) [G7TC-ID16](#) [DC24V](#) [CRT1-ID08-1](#) [84110210](#) [6422](#) [AIIS-DIO32-00A1E](#) [84110410](#) [GT1-OD16MX](#) [GRT1-PC8](#) [G7VC-OC16-B7](#) [G7TC-OC08-1](#) [DC24V](#) [G7TC-IA16](#) [AC200/220V](#) [G7TC-OC08](#) [DC24V](#) [70MRCK24-DIN](#) [2736505](#) [ODC5AQ](#)