

GT5P Series – ON Delay Timers

Key features:

- SPDT, 5A contacts
- 8-pin, octal base
- 9 time ranges
- Repeat error $\pm 0.2\%$ maximum
- Control settings by hand or screwdriver
- Power ON and timing out LED indicators
- Uses the same sockets and hold down clips as IDEC's RR2P 8-pin relays



Specifications

Rated Operating Voltage	100 to 120V AC (50/60Hz) 200 to 240V AC (50/60Hz) 24V AC/DC 12V DC
Voltage Tolerance	AC type: $\pm 15\%$ DC type: $\pm 10\%$ (ripple 10% maximum)
Contact Rating	Resistive load 120V AC/24V DC, 5A 240V AC, 3A
	Inductive load 240V AC, 0.8A 120V AC, 1.4A 24V DC, 1.7A
Allowable Contact Power (resistive load)	960VA AC 120W DC
Contact Form	SPDT
Voltage	250V AC, 150V DC
Repeat Error	$\pm 0.2\%$ $\pm 10\text{msec}$
Voltage Error	$\pm 0.5\%$ $\pm 10\text{msec}$
Temperature Error	$\pm 3\%$ maximum (over -10 to 50°C , reference temperature 20°C)
Setting Error	$\pm 10\%$ maximum
Reset Time	When turning power off after time up: 0.1 sec maximum When turning power off before time up: 1 sec maximum
Insulation Resistance	100M Ω minimum
Dielectric Strength	2000V AC, 1 minute (except between contacts of the same pole)
Vibration Resistance	100N (approximate 10G)
Shock Resistance	Operating extremes: 100N (approximate 10G) Damage limits: 500N (approximate 50G)
Power Consumption	100V AC type: 1.5VA (at 50Hz) 200V AC type: 1.6VA (at 50Hz) 24V DC type: 0.9W
Electrical Life	100,000 operations minimum (at rated load)
Mechanical Life	20,000,000 operations minimum
Operating Temperature	-10 to $+50^\circ\text{C}$
Operating Humidity	45 to 85% RH



1. Inductive load (reference), $\cos \theta = 0.3$ to 0.4 or $L/R = 15\text{msec}$.
2. Minimum applicable load: 5VDC/10mA (reference).

Part Numbering List

Mode of Operation	Contact	Output	Rated Voltage	Time Range	Complete Part No.	
ON-Delay	SPDT	24V DC/120V AC, 5A 240V AC, 3A	100 to 120V AC	1S	—	
				3S	GT5P-N3SA100	
				6S	—	
				10S	GT5P-N10SA100	
				30S	GT5P-N30SA100	
				60S	GT5P-N60SA100	
				3M	GT5P-N3MA100	
				6M	GT5P-N6MA100	
				10M	GT5P-N10MA100	
				200 to 240V AC	1S	GT5P-N1SA200
					3S	—
					6S	GT5P-N6SA200
			10S		GT5P-N10SA200	
			30S		GT5P-N30SA200	
			60S		GT5P-N60SA200	
			3M		GT5P-N3MA200	
			6M		GT5P-N6MA200	
			10M		GT5P-N10MA200	
			24V AC/DC		1S	GT5P-N1SAD24
					3S	—
					6S	GT5P-N6SAD24
				10S	GT5P-N10SAD24	
				30S	—	
				60S	GT5P-N60SAD24	
				3M	—	
				6M	GT5P-N6MAD24	
				10M	GT5P-N10MAD24	
				12V DC	1S	—
					3S	—
					6S	—
			10S		GT5P-N10SD12	
			30S		GT5P-N30SD12	
			60S		GT5P-N60SD12	
			3M		—	
			6M		—	
			10M		GT5P-N10MD12	



For sockets and accessories, see page 941.

Switches & Pilot Lights

Signaling Lights

Relays & Sockets

Timers

Contactors

Terminal Blocks

Circuit Breakers

Timing Diagram/Schematic/Electrical Life Curves

SPDT

Operation Mode

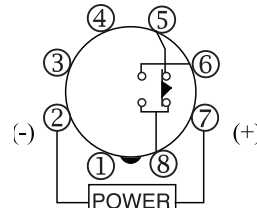

Do not apply voltage to terminals 1, 3, and 4.

ON-Delay

Item	Terminal Number	Operation
Set Time		← Operation →
Power	2 - 7 (8p)	[Green bar indicating power application]
Delayed Contact	5 - 8 (8p) (NC)	[Green bar indicating contact state]
	6 - 8 (8p) (NO)	[Green bar indicating contact state]
Indicator	POWER	[Green bar indicating power indicator]
	OUT	[Green bar indicating output indicator]

Electrical Life Curves

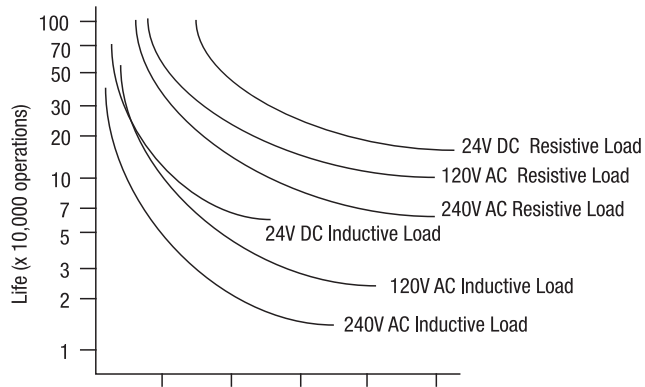

Switches & Pilot Lights

Signaling Lights

Relays & Sockets

Timers

Contactors

Terminal Blocks

Circuit Breakers

Accessories
Mounting

Mounting Accessories and Sockets					Applicable Hold-Down Springs	
Style	Appearance	Use with Timers	Part No.	Appearance	Part No.	
DIN Rail/ Surface Mounting Accessories	8-Pin Screw Terminal (dual tier)		GT5P	SR2P-05		SFA-203
	8-Pin Fingersafe Socket		GT5P	SR2P-05C		
	8-Pin Screw Terminal		GT5P	SR2P-06		SFA-202
	DIN Mounting Rail Length 1000mm		—	BNDN1000		
Part Numbers: Mounting Accessories and Sockets					Applicable Hold-Down Springs	
Mounting Accessories	8-Pin Solder Terminal			SR2P-51		SFA-402

Installation of Hold-Down Springs
DIN Rail Mount Socket

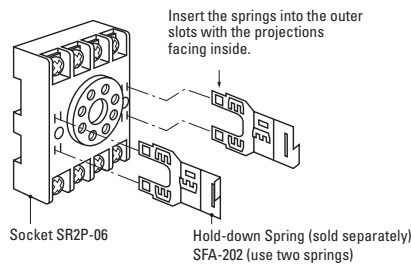
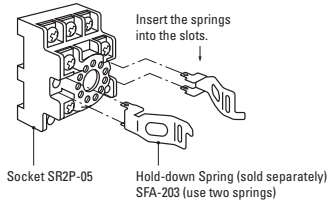

Panel Mount Socket

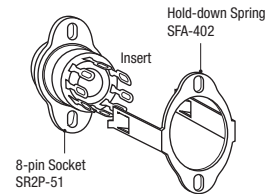

Dimensions

GT5P Timer, 8-Pin with SR2P-05
(When using DIN rail)
BAA, BAP: 102 max. (Note 2)
98 max. (Note 1)

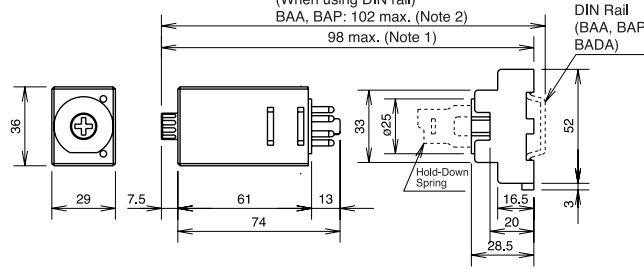

GT5P Timer, 8-Pin with SR2P-06
(When using DIN rail)
BAA, BAP: 95.5 max

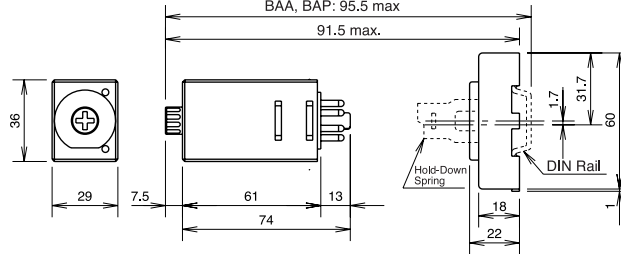

Switches & Pilot Lights

Signaling Lights

Relays & Sockets

Timers

Contactors

Terminal Blocks

Circuit Breakers

GT5Y Series – ON Delay Timers

Key features:

- 4PDT, 3A or DPDT, 5A contacts
- 4 time ranges
- Repeat error $\pm 0.2\%$ maximum
- Control settings by hand or screwdriver
- Power ON and timing out LED indicators
- Uses the same sockets and hold-down clips as IDEC's RY4S and RU series relays

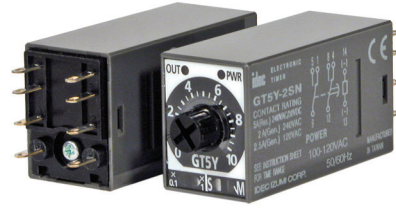

UL, c-UL Listed
File No. E55996

Specifications

		GT5Y-2	GT5Y-4
Rated Operating Voltage		100 to 120V AC (50/60Hz) 200 to 240V AC (50/60Hz) 24V DC 24V AC 12V DC	
Contact Form		DPDT	4PDT
Rated Load	Resistive Load	220V AC, 5A 30V DC, 5A	220V AC, 3A 30V DC, 3A
	Inductive Load	220V AC, 2A 30V DC, 2.5A	220V AC, 0.8A 30V DC, 1.5A
Allowable Contact Power	Resistive Load	1100VA AC 150W DC	660VA AC 90W DC
	Inductive Load Cos $\phi = 0.3$ L/R = 7msec	440VA AC 75W DC	176VA AC 45W DC
Allowable Voltage		250V AC, 125V DC	
Allowable Current		5A	3A
Temperature Error		$\pm 3\%$ maximum (over -10 to 50°C , reference temperature 20°C)	
Setting Error		$\pm 10\%$ maximum	
Reset Time		When turning power off after time up: 0.1 second maximum When turning power off before time up: 1 second maximum	
Insulation Resistance		100M Ω minimum	
Dielectric Strength		2,000V AC, 1 minute (except between contacts of the same pole)	
Vibration Resistance		100N (approximate 10G)	
Shock Resistance		Operating extremes: 100N (approximate 10G) Damage limits: 500N (approximate 50G)	
Power Consumption		100V AC type: 1.5VA (at 50Hz) 200V AC type: 1.6VA (at 50Hz) 24V DC type: 0.9W	
Electrical Life		500,000 operations minimum (220V AC, 5A)	200,000 operations minimum (110V AC, 3A)
Mechanical Life		50,000,000 operations minimum	
Operating Temperature		-10 to $+50^\circ\text{C}$	
Operating Humidity		45 to 85% RH	



1. Minimum applicable load: GT5Y-2: 5V DC, 20mA (reference value); GT5Y-4: 5V DC, 10mA (reference value).
2. Inductive load: cos $\phi = 0.3$, L/R=7msec.

Part Numbering List

Mode of Operation	Contact	Output	Rated Voltage	Time Range	Complete Part No.	
ON-Delay	DPDT	220V AC/ 30V DC, 5A	100 to 120V AC	1S/10S/1M/10M	GT5Y-2SN1A100	
				3S/30S/3M/30M	GT5Y-2SN3A100	
				6S/60S/6M/60M	GT5Y-2SN6A100	
			200 to 240V AC	1S/10S/1M/10M	GT5Y-2SN1A200	
				3S/30S/3M/30M	GT5Y-2SN3A200	
				6S/60S/6M/60M	GT5Y-2SN6A200	
			12V DC	1S/10S/1M/10M	GT5Y-2SN1D12	
				3S/30S/3M/30M	GT5Y-2SN3D12	
				6S/60S/6M/60M	GT5Y-2SN6D12	
	24V DC	1S/10S/1M/10M	GT5Y-2SN1D24			
		3S/30S/3M/30M	GT5Y-2SN3D24			
		6S/60S/6M/60M	GT5Y-2SN6D24			
	24V AC	1S/10S/1M/10M	GT5Y-2SN1A24			
		3S/30S/3M/30M	GT5Y-2SN3A24			
		6S/60S/6M/60M	GT5Y-2SN6A24			
	ON-Delay	4PDT	220V AC/30V DC, 3A	100 to 120V AC	1S/10S/1M/10M	GT5Y-4SN1A100
					3S/30S/3M/30M	GT5Y-4SN3A100
					6S/60S/6M/60M	GT5Y-4SN6A100
200 to 240V AC				1S/10S/1M/10M	GT5Y-4SN1A200	
				3S/30S/3M/30M	GT5Y-4SN3A200	
				6S/60S/6M/60M	GT5Y-4SN6A200	
12V DC		1S/10S/1M/10M	—			
		3S/30S/3M/30M	GT5Y-4SN3D12			
		6S/60S/6M/60M	—			
24V DC		1S/10S/1M/10M	GT5Y-4SN1D24			
		3S/30S/3M/30M	GT5Y-4SN3D24			
		6S/60S/6M/60M	GT5Y-4SN6D24			
24V AC	1S/10S/1M/10M	GT5Y-4SN1A24				
	3S/30S/3M/30M	GT5Y-4SN3A24				
	6S/60S/6M/60M	GT5Y-4SN6A24				

 For sockets and accessories, see page 941.

Timing Ranges

Code	Scale	Time Range Indication	Time Range
1S	0 to 10	x 0.1 S	0.1 second to 1 second
10S		x 1 S	0.2 second to 10 seconds
1M		x 0.1 M	1.2 seconds to 1 minute
10M		x 1 M	12 seconds to 10 minutes
3S	0 to 3	x 1 S	0.1 second to 3 seconds
30S		x 10 S	0.5 second to 30 seconds
3M		x 1 M	3 seconds to 3 minutes
30M		x 10 M	30 seconds to 30 minutes
6S	0 to 6	x 1 S	0.1 second to 6 seconds
60S		x 10 S	1 second to 60 seconds
6M		x 1 M	6 seconds to 6 minutes
60M		x 10 M	1 minute to 60 minutes

Switches & Pilot Lights

Signaling Lights

Relays & Sockets

Timers

Contactors

Terminal Blocks

Circuit Breakers

Timing Diagram/Schematics/Electrical Life Curves

Switches & Pilot Lights

Signaling Lights

Relays & Sockets

Internal Connections
(bottom view)

Operation Mode:
ON-Delay

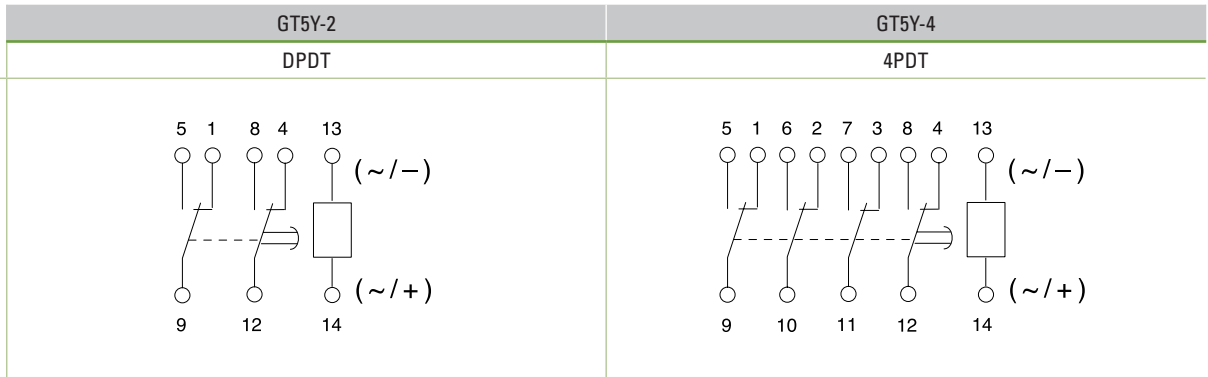

Item	Terminal Number	Operation
Set Time		
Power	13 - 14	
Delayed Contact	1 - 9, 2 - 10	(NC)
	3 - 11, 4 - 12	(NC)
	5 - 9, 6 - 10	(NO)
Indicator	POWER	
	OUT	

For an explanation of timing modes, see page 940.

Timers

Contactors

Terminal Blocks

Circuit Breakers

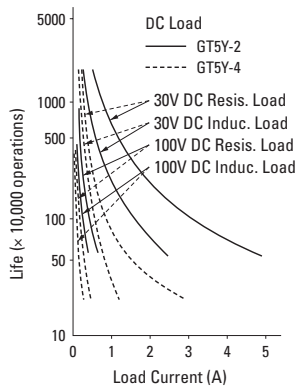
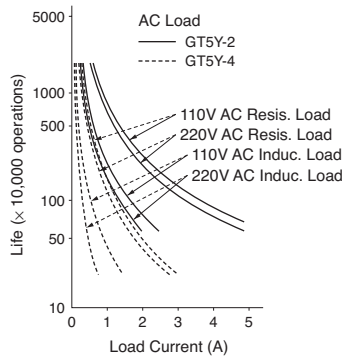

Electrical Life Curves



Accessories2

DIN Rail Mounting Accessories

DIN Rail/Surface Mount Sockets and Hold-Down Springs

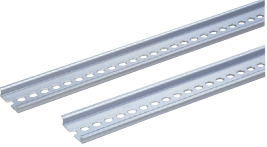
DIN Rail Mount Socket			Applicable Hold-Down Springs	
Style	Appearance	Part No.	Appearance	Part No.
14-Blade Screw Terminal		SY4S-05		SFA-202
14-Blade Screw Terminal (fingersafe)		SY4S-05C		
DIN Mounting Rail Length 1000mm		BNDN1000		



Panel Mounting Accessories

Part Numbers: Panel Mount Socket and Hold-Down Springs

Panel Mount Socket			Applicable Hold-Down Springs	
Style	Appearance	Part No.	Appearance	Part No.
14-Blade Solder Terminal		SY4S-51		SFA-302

PCB Mounting Accessories

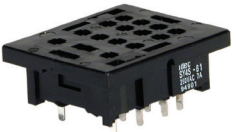
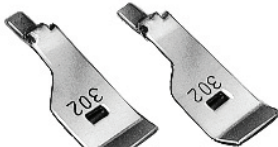
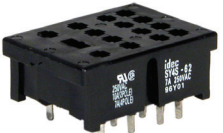
Part Numbers: PCB Mount Sockets with Applicable Hold-Down Springs

PCB Mount Socket			Applicable Hold-Down Springs	
Style	Appearance	Part No.	Appearance	Part No.
14 Blade, PCB Terminal		SY4S-61		SFA-302
14 Blade, PCB Terminal		SY4S-62		SY4S-02F1

Switches & Pilot Lights

Signaling Lights

Relays & Sockets

Timers

Contactors

Terminal Blocks

Circuit Breakers

X-ON Electronics

Largest Supplier of Electrical and Electronic Components

Click to view similar products for [Time Delay & Timing Relays](#) category:

Click to view products by [Idec](#) manufacturer:

Other Similar products are found below :

[7012GD](#) [7012L10BN](#) [7012L10DY1N](#) [7012L10FN](#) [7012L10HN](#) [7012L26K](#) [7012L8AI2LLSN](#) [7012L8BN](#) [7012L8KN](#) [7012OBILM](#)
[7012OIT](#) [7012PALL](#) [7012PDM](#) [7012PFX](#) [7022L10DN](#) [7022L8BN](#) [7022L8EN](#) [7022L8HN](#) [7022X3D](#) [7024NB](#) [7024SCT](#) [88256455](#) [H3BG-](#)
[N8H](#) [AC110V](#) [H3CRF8AC2448DC1248](#) [1423151-3](#) [1423154-8](#) [1423462-7](#) [1423618-6](#) [1423151-5](#) [1423156-7](#) [1423618-4](#) [2112AH1SDC947](#)
[2122DH1NJC467](#) [2122DH1PE](#) [2-1617805-2](#) [2-1617805-6](#) [K61C-08](#) [286XCXC-300-24D](#) [SCBRX022XXACXAC991](#) [SHS10S110A](#)
[SHS20M220A](#) [1755074-5](#) [SSC12AKA](#) [FAASPRING2](#) [2112DH3NDC50-13](#) [2122DH34NDC629](#) [2-1437479-8](#) [2-1617805-1](#) [2-1617805-3](#) [2-](#)
[1617805-7](#)