

# HS5B Miniature Safety Interlock Switches

Available with a robust and durable metal head.

Choice of three gland port sizes: G1/2, PG13.5, and M20

- Actuators are interchangeable with the HS5E safety door lock switches.
- Actuators with rubber bushings are ideal for rattling doors.
- RoHS directive compliant.
- Double insulation structure eliminates the need for grounding.
- The head orientation can be changed, allowing 8 different actuator entries.
- Degree of protection (contacts): IP67 (IEC60529)
- NC contacts are of direct opening action (IEC/EN60947-5-1).
- Proprietary actuators prevent unauthorized opening of the contacts (ISO14119, EN1088).
- Compact body: 30 × 30 × 91 mm



## Types

Contact Configuration	Gland Port Size	Type No. (Package quantity: 1)	
		Plastic Head Type	Metal Head Type
1NC-1NO 	G1/2	HS5B-11B	HS5B-11ZB
	PG13.5	HS5B-11NP	—
	M20	HS5B-11BM	HS5B-11ZBM
2NC 	G1/2	HS5B-02B	HS5B-02ZB
	PG13.5	HS5B-02NP	—
	M20	HS5B-02BM	HS5B-02ZBM

## Actuators

Description	Type No. (Package quantity: 1)
Straight	HS9Z-A51
Straight w/rubber bushing	HS9Z-A51A
L-shaped	HS9Z-A52
L-shaped w/rubber bushing	HS9Z-A52A
Angle Adjustable (for hinged doors)	HS9Z-A55

## Parts Description

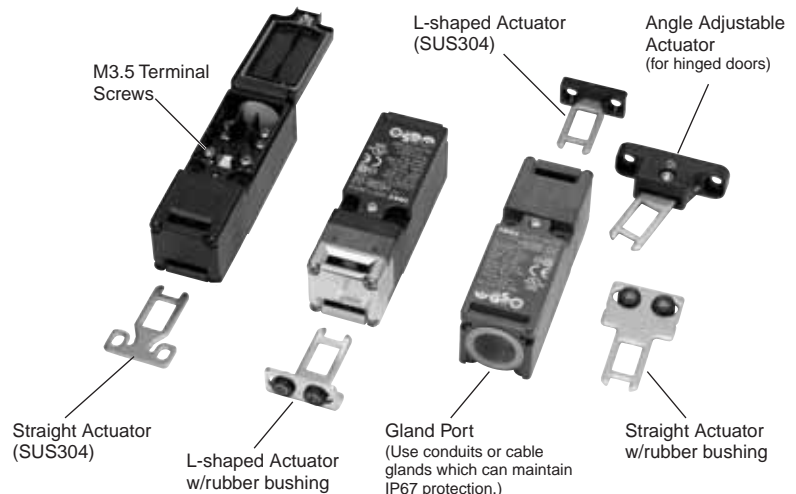

# HS5B Miniature Safety Interlock Switches

## Type No. Development

<b>HS5B - 11 Z BM</b>	
<b>Circuit Code</b>	<b>Head Housing Color / Gland Port</b>
11: 1NC-1NC	B: Black / G1/2
02: 2NC	BM: Black / M20
<b>Head Material</b>	NP: Gray / PG13.5
blank: Plastic	
Z: Metal	

## Contact Ratings

Rated Insulation Voltage (Ui)		300V			
Rated Current (Ith)		10A			
Rated Voltage (Ue) *		30V	125V	250V	
Rated Current (Ie) *	AC	Resistive load (AC-12)	10A	10A	6A
		Inductive Load (AC-15)	10A	5A	3A
	DC	Resistive load (DC-12)	8A	2.2A	1.1A
		Inductive Load (DC-13)	4A	1.1A	0.6A

• Minimum applicable load (reference): 3V AC/DC, 5mA

\* Ratings approved by safety agencies: A300 (UL/c-UL), AC-15 3A/250V (TÜV, BG)

## Specifications

Applicable Standards	ISO14119 EN1088 IEC60947-5-1 EN60947-5-1 (TÜV approval) GS-ET-15 (BG approval) UL508 (UL listed) CSA C22.2, No. 14 (c-UL listed)  IEC60204-1/EN60204-1 (applicable standards for use)
Applicable Directive	73/23/EEC (Low Voltage Directive)
Operating Temperature	-20 to +70°C (no freezing)
Relative Humidity	45 to 85% (no condensation)
Storage Temperature	-40 to +80°C (no freezing)
Pollution Degree	3
Impulse Withstand Voltage	4 kV
Insulation Resistance (500V DC megger)	Between live and dead metal parts: 100 MΩ minimum Between terminals of different poles: 100 MΩ minimum
Electric Shock Protection Class	Class II (IEC61140)
Degree of Protection	IP67 (IEC60529)
Shock Resistance	Damage limits: 1000 m/s <sup>2</sup> (approx. 100G)
Vibration Resistance	Operating extremes: 10 to 55 Hz, amplitude 0.5 mm minimum Damage limits: 30 Hz, amplitude 1.5 mm minimum
Actuator Operating Speed	0.05 to 1.0 m/s
Direct Opening Travel	8 mm minimum
Direct Opening Force	60N minimum
Operating Frequency	900 operations per hour
Mechanical Life	1,000,000 operations minimum (GS-ET-15)
Electrical Life	100,000 operations minimum (operating frequency 900 operations per hour, load AC-12, 250V, 6A)
Conditional Short-circuit Current	100A (250V) (Use 250V/10A fast acting type fuse for short circuit protection.)
Housing Color	Black (gland port: G1/2, M20) Gray (gland port: PG13.5)
Weight (approx.)	Plastic head: 80g Metal head: 110g

# HS5B Miniature Safety Interlock Switches

## Dimensions and Mounting Hole Layouts

### • Plastic Head

#### Using the HS9Z-A51 Straight Actuator

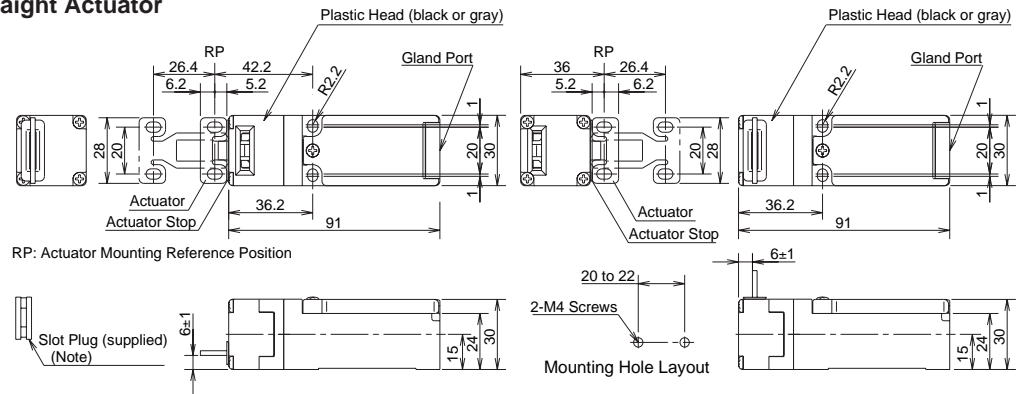

#### Using the HS9Z-A52 L-shaped Actuator

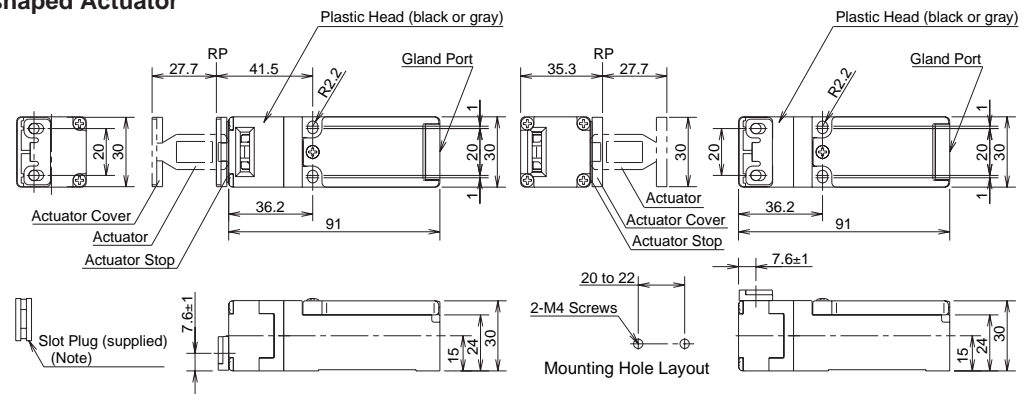

Note: Plug the unused actuator entry slot using the slot plug supplied with the safety interlock switch.

### • Metal Head

#### Using the HS9Z-A51 Straight Actuator

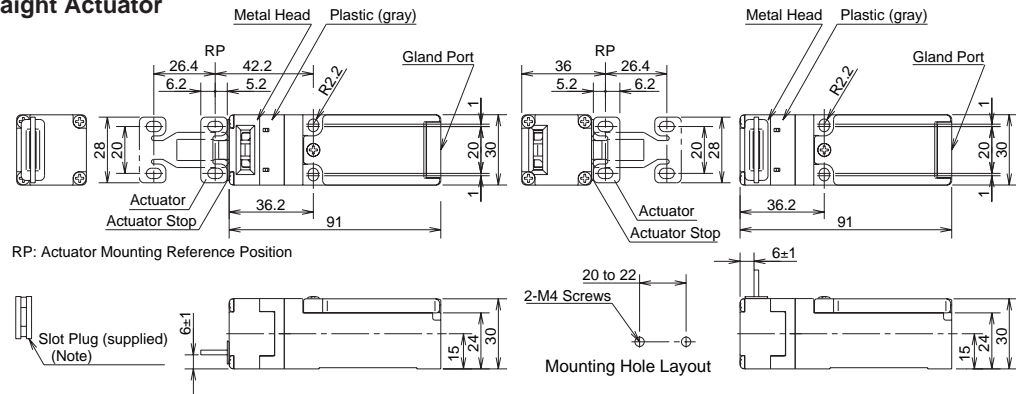

#### Using the HS9Z-A52 L-shaped Actuator

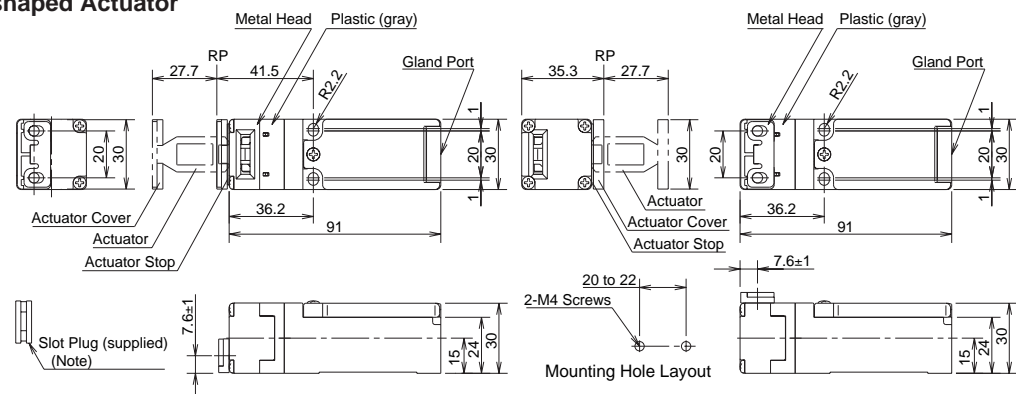

Note: Plug the unused actuator insertion slot using the slot plug supplied with the safety interlock switch.

All dimensions in mm.

# HS5B Miniature Safety Interlock Switches

## Actuator Dimensions

### Straight (HS9Z-A51)

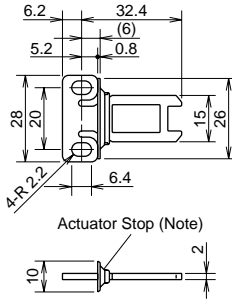

### L-shaped (HS9Z-A52)

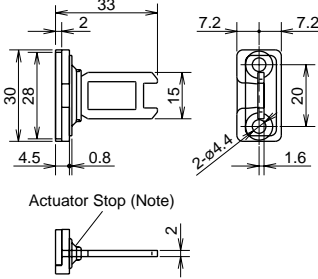

### Straight w/rubber bushing (HS9Z-A51A)

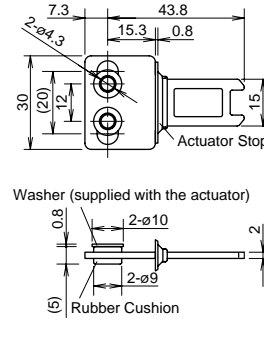

### L-shaped w/rubber bushing (HS9Z-A52A)

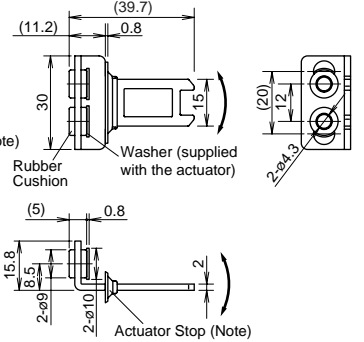

- Actuator Mounting Hole Layout (Straight, L-shaped)

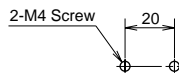

- The mounting center distance is set to 12 mm at factory. When 20-mm distance is required, adjust the distance by moving the rubber bushings.
- The actuator has flexibility to the directions indicated by the arrows. When 20-mm distance is selected, the actuator swings vertically.

- Actuator Mounting Hole Layout (Straight w/rubber cushion) (L-shaped w/rubber cushion)

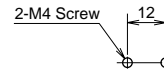

Mounting centers can be widened to 20 mm by moving the rubber cushions.

### Angle Adjustable (HS9Z-A55)

#### Horizontal Swing

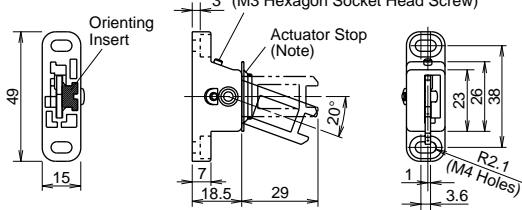

#### Vertical Swing

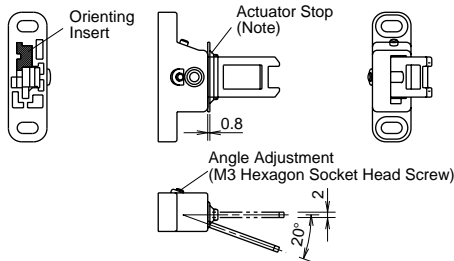

- Actuator Mounting Layout (horizontal/vertical swing)

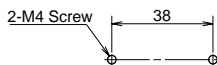

Note: The actuator stop is supplied with the actuator and used when adjusting the actuator position. Remove the actuator stop after the actuator position is determined.

- Actuator Orientation (Angle Adjustable)

The angle of actuator swing can be changed using the orienting insert (white plastic) installed on the back of the actuator. Do not lose the orienting insert, otherwise the actuator will not operate properly.

All dimensions in mm.

## Contact Configuration and Operation Chart

Type	Contact Configuration	Contact Operation Chart	Contact Status
HS5B-11	1NC-1NO 		
HS5B-02	2NC 		

# HS5B Miniature Safety Interlock Switches

## Safety Precautions

- In order to avoid electric shock or fire, turn the power off before installation, removal, wire connection, maintenance, or inspection of the switch.
- If relays are used in the circuit between the safety interlock switch and the load, use only safety relays, since welded or sticking contacts of standard relays may invalidate the functions of the safety interlock switch. Perform risk assessment and make up a safety circuit which satisfies the requirements of the safety category.
- Do not place a PLC in the circuit between the safety interlock

switch and the load. Safety security can be endangered in the event of a malfunction of the PLC.

- Do not disassemble or modify the safety interlock switch, otherwise a malfunction or an accident may occur.
- Do not install the actuator in the location where a human body may come in contact. Otherwise injury may occur.
- When the head is removed to change the head orientation, the NC contact is turned on (closed). Make sure that the head is secured in place before installing the safety interlock switch.

## Instructions

- Regardless of door types, do not use the safety interlock switch as a door stop. Install a mechanical door stop at the end of the door to protect the safety interlock switch against excessive force.
- Do not apply excessive shock to the safety interlock switch when opening or closing the door. A shock to the safety interlock switch exceeding  $1,000 \text{ m/s}^2$  may cause damage to the safety interlock switch.
- When wiring the terminals, open the hinged lid only. Do not open any other part of the safety interlock switch.
- While connecting a cable gland or wiring the terminals, prevent foreign objects from entering the safety interlock switch, such as dust and liquids.
- If the operating atmosphere is contaminated, use a protective cover to prevent the entry of foreign objects into the safety interlock switch through the actuator entry slots.
- Entry of a considerable amount of foreign objects into the safety interlock switch may affect the mechanism of the safety interlock switch and cause a malfunction.
- Plug the unused actuator entry slot using the slot plug supplied with the safety interlock switch.
- Do not store the safety interlock switches in a dusty, humid, or organic-gas atmosphere.
- Use proprietary actuators only. When other actuators are used, the safety interlock switch may be damaged.
- Although the HS9Z-A51A and HS9Z-A52A actuators (w/rubber bushings) alleviate shock when the actuator enters the slot in the safety interlock switch, make sure that excessive shocks are not applied. When the rubber bushings are deformed or cracked, replace with new ones.

## Minimum Radius of Hinged Door

- When using the safety interlock switch on hinged doors, refer to the minimum radius of doors shown below. When using on doors with small minimum radius, use the angle adjustable actuator (HS9Z-A55).

Note: Because deviation or dislocation of hinged doors may occur in actual applications, make sure of the correct operation before installation.

### When using the HS9Z-A52 Actuator

- When the center of the hinged door is on the extension line of the contact surface of actuator and safety interlock switch:

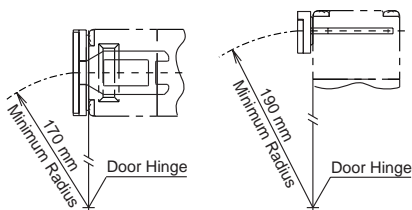

- When the center of the hinged door is on the extension line of the actuator mounting surface:

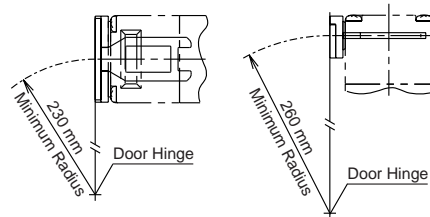

### When using the HS9Z-A55 Angle Adjustable Actuator

- When the center of the hinged door is on the extension line of the contact surface of actuator and safety interlock switch: 50 mm
- When the center of the hinged door is on the extension line of the actuator mounting surface: 70 mm

#### Horizontal Swing

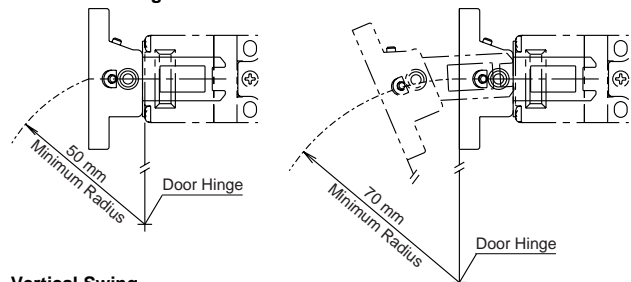

#### Vertical Swing

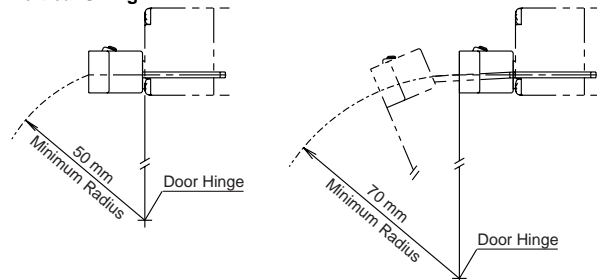

### Actuator Angle Adjustment for the HS9Z-A55

- Using the angle adjustment screw, the actuator angle can be adjusted (see figures on page 5).  
Adjustable angle: 0 to 20°
- The larger the adjusted angle of the actuator, the smaller the applicable radius of the door opening.
- After installing the actuator, open the door. Then adjust the actuator so that its edge can be inserted properly into the actuator entry slot of the safety interlock switch.
- After adjusting the actuator angle, apply Loctite to the adjustment screw so that the screw will not loosen.

# HS5B Miniature Safety Interlock Switches

## Mounting Examples

- Mount the safety interlock switch as shown in the examples below.

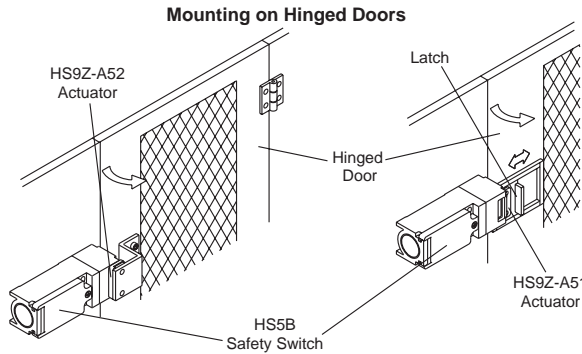
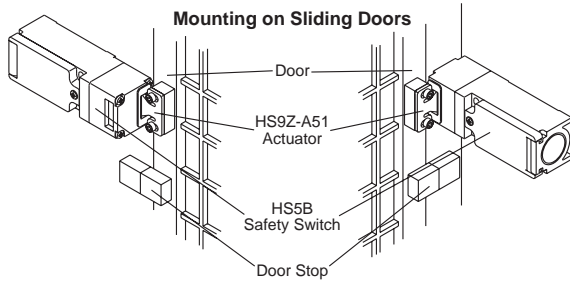

## Mounting the HS5B Head

- The metal head for the HS5E safety door lock switch cannot be used on the HS5B. Be sure to use the plastic head or metal head for the HS5B. Take care particularly when using both HS5B and HS5E together.

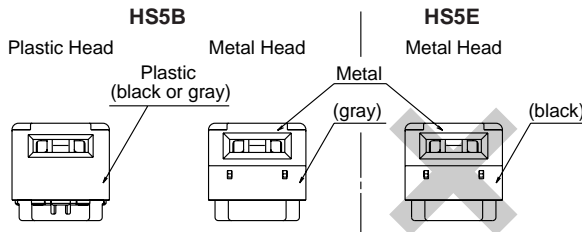

Note: Metal heads of the HS5B and HS5E have different plastic parts.

## Rotating the Head

- The head of the HS5B can be rotated by removing the four screws from the corners of the HS5B head and reinstalling the head in the desired orientation. When reinstalling the head, make sure that no foreign object enters the safety interlock switch. Tighten the screws tightly, because loose tightening may cause malfunction.
- Recommended screw tightening torque:  $1.0 \pm 0.1$  N·m

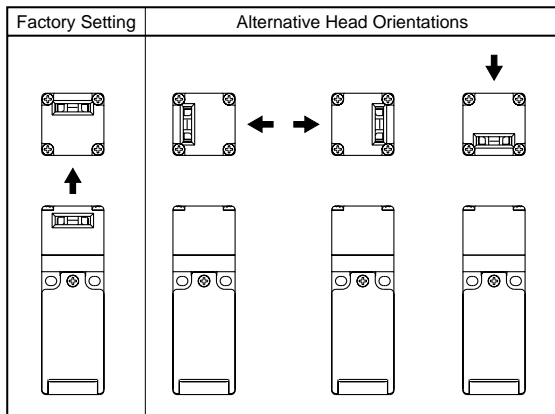

## Applicable Crimping Terminal

- When using crimping terminals, be sure to install insulation tubes on the crimping terminals to prevent electric shocks.

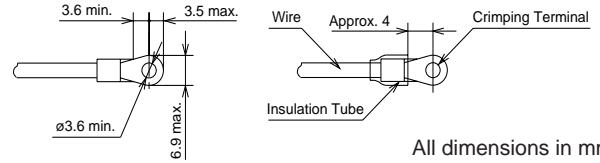

All dimensions in mm.

## Applicable Wire Size

- 0.5 to 1.25 mm<sup>2</sup> (AWG20 to AWG16)

## Recommended Tightening Torque of Mounting Screws

- Safety Interlock Switch:  $2.0 \pm 0.2$  N·m (two M4 screws) \*
- Actuators
  - HS9Z-A51:  $2.0 \pm 0.2$  N·m (two M4 screws) \*
  - HS9Z-A52:  $1.0 \pm 0.2$  N·m (two M4 Phillips screws)
  - HS9Z-A51A/A52A: 1.0 to 1.5 N·m (two M4 screws) \*
  - HS9Z-A55: 1.0 to 1.5 N·m (two M4 screws) \*

\* The above recommended tightening torques of the mounting screws are the values confirmed with hex socket head bolts. When other screws are used and tightened to a smaller torque, make sure that the screws do not come loose after mounting.

- Mounting bolts must be provided by the users.
- To avoid unauthorized or unintended removal of the safety interlock switch and the actuator, it is recommended that the safety interlock switch and the actuator be installed in an unremovable manner, for example using special screws or welding the screws.
- When installing the HS9Z-A51A or HS9Z-A52A actuators, use the washer (supplied with the actuator) on the hinged door, and mount tightly using two M4 screws.

## Mounting centers:

12 mm (factory setting), adjustable to 20 mm

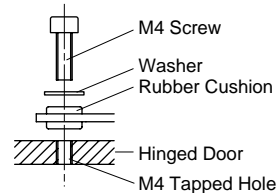

Note: Choose mounting centers either 12 mm or 20 mm.

## Gland Port Size Identification

- Gland port size is identified by the arrow on the back of the HS5B safety interlock switch. The following example shows the identification of the M20 gland port size.

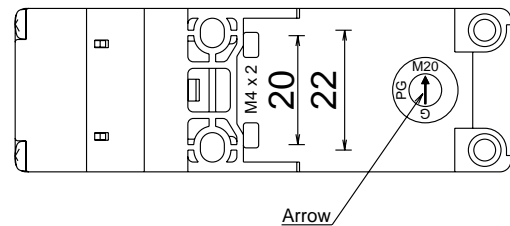

Marking	Gland Port Size
G	G1/2
PG	PG13.5
M20	M20

## X-ON Electronics

Largest Supplier of Electrical and Electronic Components

*Click to view similar products for [Idec manufacturer](#):*

Other Similar products are found below :

[LT7A-XE-G](#) [LT7A-XE-R](#) [LT7B-A250](#) [LT7B-A250FB](#) [LW6L-M1C24MG](#) [FB1T-000Z](#) [FB1W-HW1B-V411R-EMO-2](#) [FB1W-XW1E-BV411MR](#) [FB1W-XW1E-BV413MR](#) [FB3W-413Z](#) [FC2A-KP1C](#) [FC4A-J8AT1](#) [FC4A-T16S3](#) [FC5A-C16R2C](#) [MM-SMART-24](#) [MM-SMART-40](#) [FT1A-C12RA-S](#) [FT1A-C12RA-W](#) [FT1A-C14SA-B](#) [PF3S-BP12](#) [PS3X-D24AFG](#) [PS3X-Q12AFG](#) [GT3A-3AD24](#) [GT3F-2EAD24](#) [GT3S-2AF20](#) [GT3W-A16AD24](#) [GT3W-A33AF20N](#) [ABD302N-R](#) [ABD410N-R](#) [ABFD411N-G](#) [ABN4F11-G](#) [HE2B-M211PB](#) [HE2G-21SH](#) [HE9Z-D3B](#) [HG9Z-2A1](#) [HG9Z-XC300](#) [ACSNO-6123-FB-C6002](#) [RH3V2-UAC240V](#) [DFAN-031-B](#) [AL6M-LK1-G](#) [AL6M-P3-R](#) [AL6Q-M13-W](#) [AL6Q-M23P-QG](#) [ALFD29901DN-G-24V](#) [ALFN22211DNG-U](#) [ALFW224611D-W](#) [ALNE8811-G](#) [ALQW2B24611D-G](#) [ALW212611-G](#) [ALW22211DG](#)