

## HS1B Full Size Interlock Switches

### Key features:

- Rugged aluminum die-cast housing
- Direct Opening Action
- Available with or without an indicator (red or green)
- Flexible Installation: Two actuator entries and three conduit ports are provided
- Select from two circuit configurations (1NO-1NC or 2NC).
- IP67



### Part Numbers Body

Model	Contact Configuration	Pilot Light	Part Number
	1NC-1NO	Without	<b>HS1B-11R</b>
		Red LED	HS1B-114R-R
		Green LED	HS1B-114R-G
	2NC	Without	<b>HS1B-02R</b>
		Red LED	HS1B-024R-R
		Green LED	<b>HS1B-024R-G</b>

Standard stock items in bold.

### Actuator Keys and Accessories (order separately)

Appearance	Part Number	Description
	HS9Z-A1	Straight Actuator (Mainly for sliding doors)
	HS9Z-A2	Right-angle Actuator (Mainly for rotating doors)
	HS9Z-A3	Adjustable Actuator
	HS9Z-T1	Key Wrench (included with switch)
	HS9Z-P1	Conduit Opening Plug

Actuators are not included and must be ordered separately.

### Specifications

Conforming to Standards	IEC60947-5-1, EN60947-5-1, GS-ET-15, UL508, CSA C22.2 No. 14	
Operating Temperature	-20 to +70°C (no freezing)	
Storage Temperature	-40 to +80°C	
Relative Humidity	45 to 85% (no condensation)	
Altitude	2,000m maximum	
Rated Insulation Voltage (U <sub>i</sub> )	300V (between LED and ground: 60V)	
Impulse Withstand Voltage (U <sub>imp</sub> )	4 kV (between LED and ground: 2.5 kV)	
Insulation Resistance	Between live and dead metal parts: 100 MΩ minimum Between live metal part and ground: 100 MΩ minimum Between live metal parts: 100 MΩ minimum Between terminals of the same pole: 100 MΩ minimum	
Electric Shock Protection Class	Class I (IEC61140)	
Pollution Degree	3 (IEC60947-5-1)	
Degree of Protection	IP67 (IEC60529)	
Vibration Resistance	Operating Extremes	10 to 55 Hz, amplitude 0.5mm p-p
	Damage Limits	60 m/sec <sup>2</sup> (approx. 6G)

Shock Resistance	1,000 m/sec <sup>2</sup> (approx. 100G)	
Actuator Operating Speed	0.05 to 1.0m/s	
Direct Opening Travel	11 mm minimum	
Direct Opening Force	20N minimum	
Thermal Current (I <sub>th</sub> )	10A	
Operating Frequency	900 operations/hour	
Mechanical Life	1,000,000 operations	
Electrical Life	100,000 operations (rated load)	
Conditional Short-circuit Current	100A (IEC60947-5-1)	
Recommended Short Circuit Protection	250V, 10A fuse (Type D01 based on IEC60269-1, 60269-2)	
Indicator	Operating Voltage	24V DC
	Current	10 mA
	Light Source	LED lamp
	Lens Color	Red or Green (12 mm dia. Lens)
Weight	Approx. 280g	

**Contact Ratings**

Rated Operating Current (I <sub>o</sub> )		Operating Voltage (U <sub>o</sub> )		
		30V	125V	250V
AC	Resistive load (AC12)	10A	10A	6A
	Inductive load (AC15)	10A	5A	3A
DC	Resistive load (DC12)	8A	2.2A	1.1A
	Inductive load (DC13)	4A	1.1A	0.6A

**Application Examples and Circuit Diagrams**

	Status 1	Status 2		Status 1	Status 2
Door/ Switch Status	Door Closed Machine ready to operate	Door opened Machine cannot be started	Door/ Switch Status	Door Closed Machine ready to operate	Door opened Machine cannot be started
Door			Door		
HS1B-11 (1NO-1NC) Circuit Diagram			HS1B-02 (2NC) Circuit Diagram		
Main Circuit	3-4: Closed	3-4: Open	Main Circuit	3-4: Closed	3-4: Open
Aux. Circuit	1-2: Open	1-2: Closed	Aux. Circuit	1-2: Closed	1-2: Open

1. Main Circuit: used to enable the machine to start only when the main circuit is closed. Auxiliary Circuit: used to indicate whether the main circuit or door is open or closed.
2. Terminals + and - are used for the LED indicator, and are isolated from door status. Wire the terminals only when needed.

Dimensions (mm)

Using the straight actuator (HS9Z-A1)  
(Horizontal Mounting)

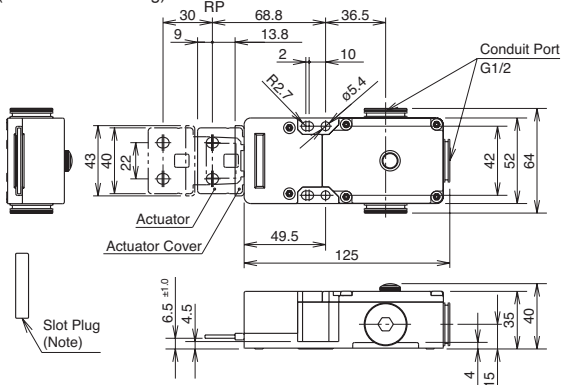

Using the Right-angle actuator (HS9Z-A2)  
(Horizontal Mounting)

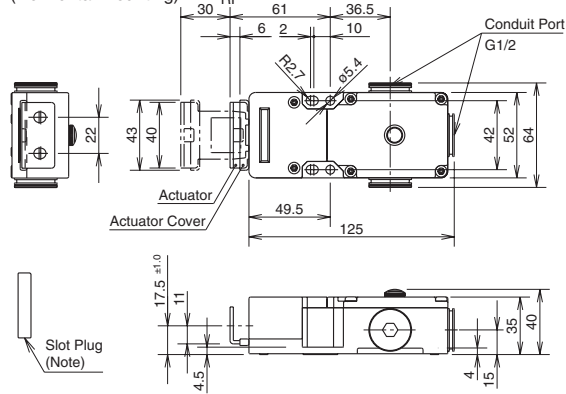

(Vertical Mounting)

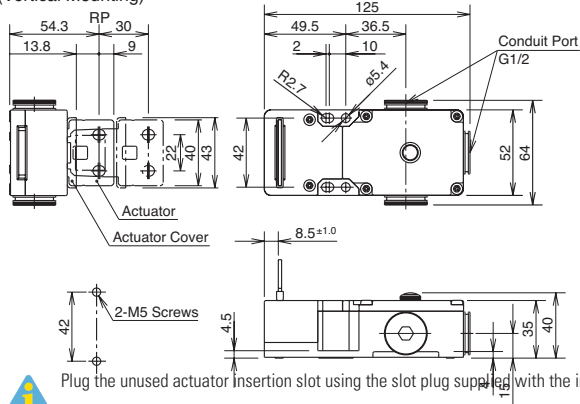

(Vertical Mounting)

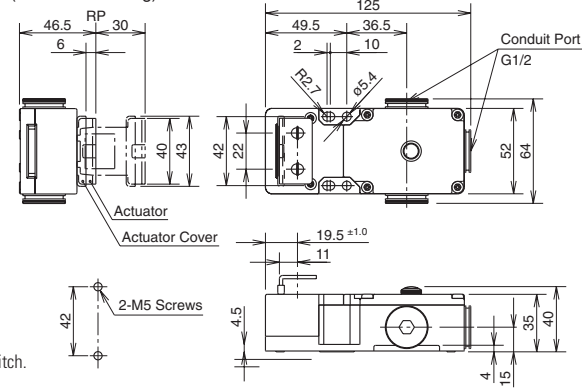

Plug the unused actuator insertion slot using the slot plug supplied with the interlock switch.

Actuator Dimensions

Straight Actuator HS9Z-A1

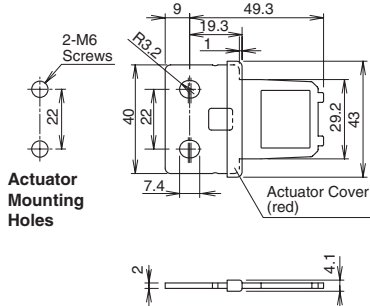

Right-angle Actuator HS9Z-A2

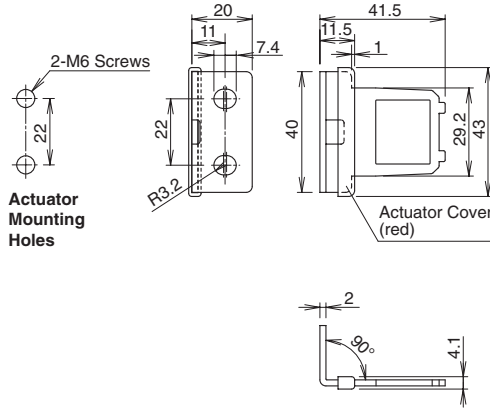

Angle-adjustable Actuator HS9Z-A3

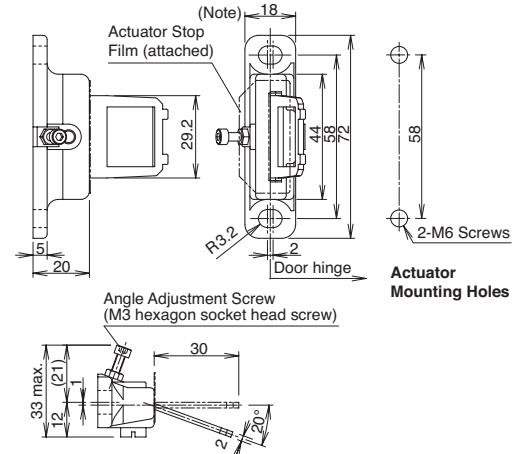

Adjustable Actuator

The actuator angle is adjustable (0° to 20°) for hinged doors.  
The minimum radius of the door opening can be as small as 100mm.

Actuator Angle Adjustment

- Using the screw (M3 hex socket head screw), the actuator angle can be adjusted (refer to the dimensional drawing). Adjustable angle: (0°) to 20°
- The larger the adjusted angle of the actuator, the smaller the applicable

radius of the door opening.

- After installing the actuator, open the door. Then adjust the actuator so that its edge can be inserted properly into the entry slot of the safety switch.
- Recommended tightening torque: 0.8 N-m (approx. 8.0 kgf-cm)
- After adjusting the actuator angle, apply loctite or the like to the adjustment screw to prevent it from loosening.

## X-ON Electronics

Largest Supplier of Electrical and Electronic Components

*Click to view similar products for [Switch Fixings](#) category:*

*Click to view products by [Idec](#) manufacturer:*

Other Similar products are found below :

[893102000](#) [00-5150](#) [LZZ1A](#) [0098.9234](#) [61-9451.0](#) [M2PA-5011](#) [630155](#) [635401](#) [6PA113](#) [6PA147-E6](#) [6PA148-E6](#) [6PA32](#) [6PA9](#) [700106](#)  
[700109](#) [700303A56](#) [700C1GRY](#) [700C2GRN](#) [704-6001](#) [704.960.9](#) [704.965.2](#) [704.965.6](#) [704.966.0](#) [7089-3](#) [710082-B11](#) [71M1048](#)  
[757200264](#) [764300000](#) [MHU35](#) [MHU37](#) [807039-1](#) [825.003.011](#) [825.005.011](#) [825.053.011](#) [825.055.011](#) [826.000.071](#) [827.020.011](#)  
[827.400.021](#) [835.900.023](#) [MML52C10C](#) [MML52E10C](#) [MML92HGH](#) [MML93K](#) [84211M02CNNS](#) [84212M02CNNS](#) [84217A8.0LNOS](#)  
[842.500.011](#) [843187-000](#) [843487-000](#) [84-901](#)