



The fastest PLC in its class

IDEC controllers offer speed, power, performance and precision, as well as being easy to use, and easy to maintain. Just a simple, ready-made solution that won't require time you don't have to give. Instead, save time with a reliable product that gives you faster response, better throughput, and less downtime. For more information, visit www.idec.com/plc.

For more information on current IDEC products, visit www.idec.com/usa or call 800-262-IDEC.

For additional information on IDEC-DATASENSOR products or DATASENSOR products, visit www.idec-ds.com.

800-262-IDEC
www.idec.com/usa



Get the power you need

IDEC power supplies offer worldwide approvals, universal voltage inputs, fused inputs, auto-resetting overload protection and various styles. In fact, the new PS5R Slim Line models give you all the power of a traditional power supply in only half the space. Utilize them in tight places or save valuable DIN Rail space while still filling your requirements for power. For more information, visit www.idec.com/powersupply.



Product Support

Technical support:

support@idec.com

Sales support:

sales@idec.com



Think Automation and beyond...

**Complete line of IDEC
 and IDEC-DATASENSOR
 products inside**



www.idec.com

USA
 IDEC Corporation
 Tel: (408) 747-0550
opencontact@idec.com

Canada
 IDEC Canada Ltd.
 Tel: (905) 890-8561
sales@ca.idec.com

Australia
 IDEC Australia Pty. Ltd.
 Tel: +61-3-9763-3244
sales@au.idec.com

Japan
 IDEC Corporation
 Tel: +81-6-6398-2571
products@idec.co.jp

United Kingdom
 IDEC Electronics Ltd.
 Tel: +44-1256-321000
sales@uk.idec.com

Germany
 IDEC Elektrotechnik GmbH
 Tel: +49-40-253054-0
service@idec.de

Hong Kong
 IDEC (H.K.) Co., Ltd.
 Tel: +852-2803-8989
info@hk.idec.com

China/Beijing
 IDEC (Beijing) Corporation
 Tel: +86-10-6581-6131
idec@cn.idec.com

China/Shanghai
 IDEC (Shanghai) Corporation
 Tel: +86-21-5353-1000
idec@cn.idec.com

China/Shenzhen
 IDEC (Shenzhen) Corporation
 Tel: +86-755-8356-2977

Singapore
 IDEC Asia Pte. Ltd.
 Tel: +65-6746-1155
info@sg.idec.com

Taiwan
 IDEC Taiwan Corporation
 Tel: +886-2-2698-3929
service@tw.idec.com

©2007 IDEC Corporation. All Rights Reserved.
 Catalog No. DS9Y-C100-0 9/07 15K

Specifications and other descriptions in this catalog are subject to change without notice.

Optical Sensing Devices

Optical Sensing Devices



Headquartered in Osaka, Japan, Idec Corporation is a global manufacturer known worldwide for 60 years for its reliable and innovative control and automation products. In the United States, Idec has over thirty local sales offices to assist customers with choosing the right switches, relays, power supplies, PLCs, O/Is, sensors and more. A leader in the industry, Idec produces only the highest quality products. In 2005, Idec received the first Monozukuri Nippon Grand Award, a Prime Ministerial award, from the Japanese government for developing a robot-controlled cell production system, a new paradigm in manufacturing. Idec was commended for the system's excellent productivity and safety, as well as its ability to produce high-quality products. The system, which was built with cutting-edge Idec safety control devices and ergonomic considerations, conforms to ISO12100, and has produced more than 20 million units of control devices from August 2000 to the present.



DATASENSOR, a spin-off from DATALOGIC, was established in Italy over 35 years ago to develop photoelectric sensors for industrial automation. Now, in partnership with Idec, you will have access to these products in the United States. DATASENSOR has won many awards including the prestigious International Best Factory Award in 2005 and 2006, "for exceptional manufacturing and logistic performance achieved through the application of an array of tools and management practices." DATASENSOR is also the third largest photoelectric sensor manufacturer in Europe; Italy's foremost market leader; and the largest manufacturer of 18mm-style tubular photoelectric sensors in the world! In fact, DATASENSOR products are so innovative, they hold over twenty patents and trademarks and boast many brand name customers.



IDEC DATASENSOR website

For additional information on IDEC-DATASENSOR products or DATASENSOR products, visit www.idec-ds.com.



IDEC website

For information on IDEC products, visit www.idec.com/usa.

Find your local IDEC Representative

Visit www.idec.com/usa/locator or call 800-262-IDEC.



Automation & Sensing



Safety & Explosion



Control & Switching



For years, customers have been using IDEC solutions to get precision optical sensors for color detection, water detection and laser measurement. Now, with this partnership, you get the same reliable, high-quality products, as well as our superior customer service and support, while gaining additional solutions for all your sensing needs. Knowledgeable IDEC Field Sales are ready to assist in the selection of products and to support your design-in process. So keep your eyes peeled for exciting, new products from IDEC-DATASENSOR in the field of safety, machine vision and application specific products.



from left: Mikio Funaki, IDEC President; Lamberto Girolomoni, DATASENSOR Chief Executive Officer and Peter J. Tarantino, IDEC VP Global Business Development

Note: IDEC and DATASENSOR have co-branded select products specifically for our customers. These IDEC-DATASENSOR branded products will be stocked, marketed and sold through established IDEC automation channel partners. In addition, DATASENSOR branded products that have not been co-branded with IDEC can still be ordered through your local IDEC distributor. Access to the complete DATASENSOR catalog will be available at www.idec-ds.com.



















- Selection Guide.....2
- Universal Sensors7
 - Tubular: S51 Series.....7
 - Compact: S60 Series.....11
 - Compact: S62 Series.....24
 - Miniature Photoelectric: SA1E32
 - Fiber Optic Analog: SA1C-FK.....38
 - High-speed Fiber Optic: SA1C-F41
 - Accessories45
- Application Sensors62
 - Color: S65-V62
 - Color: SA1J/SA1J-F.....66
 - Contrast: TL46.....72
 - Luminescence: LD4676
 - Fork/Slot: SR2180
 - Distance: S80.....83
 - Distance: SA1D87
 - Distance: MX1C90
 - Area: AS194
 - Area: DS198
 - Magnetic: DPRI101
 - Accessories103
- Laser Safety Information..... 106
- General Information..... 107



Note: IDEC-DATASENSOR branded products are indicated by a combined logo.

Selection Guide

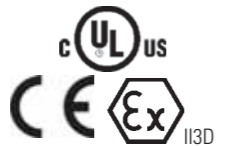
Universal Photoelectric Sensors

		Tubular	Compact			
						
Page		133	137	150	158	
Series		S51	S60	S62	SA1E	
Optic Function	Through-beam		0 - 20m	0 - 20m	-	0 - 15m
	Retro-reflective (on R2 reflector)		0.1 - 4m	-	-	-
	Polarized Retro-reflective (on R2 reflector)		0.1 - 3m	0.1 - 8m	0.3 - 20m 	0.05 - 4m
	Retro-reflective for Transparent Objects (on R2 reflector)		-	0 - 1.7m (coaxial)	-	-
	Diffuse Proximity		0 - 10cm 1 - 45cm	1 - 100cm 5 - 200cm	-	0 - 70cm 5 - 15cm
	Background Suppression		-	7 - 20cm  5 - 10cm	30 - 300mm, 60 - 600mm 60 - 1200mm, 200 - 2000mm 30 - 150mm, 50 - 350mm 	5 - 25cm
	Through-beam with Fiber Optic		-	-	-	-
	Diffuse Proximity with Fiber Optic		-	-	-	-
Specifications	Power Supply	V DC	10 - 30	10 - 30	10 - 30	10 - 30
	Output	PNP	√	√	√	√
		NPN	√	√	√	√
	Connection	Cable	√	-	-	√
		Connector	√	√	√	√
	Dimensions (mm)		M18 x 55/68	15 x 50 x 50	18 x 50 x 50	11 x 31 x 19
	Housing Material		PBT	ABS	ABS	PC/PBT
Mechanical Protection		IP67				
Approvals						

Universal Photoelectric Sensors





Fiber Optic









		Page	164	167
		Series	SA1C-FK	SA1C-F
Optic Function	Through-beam		–	–
	Retro-reflective (on R2 reflector)		–	–
	Polarized Retro-reflective (on R2 reflector)		–	–
	Retro-reflective for Transparent Objects (on R2 reflector)		–	–
	Diffuse Proximity		–	–
	Background Suppression		–	–
	Through-beam with Fiber Optic		0 - 180mm	0 - 180mm
	Diffuse Proximity with Fiber Optic		0 - 60mm	0 - 60mm
Specifications	Power Supply	V DC	12 - 24	10 - 30
	Output	PNP		√
		NPN	√	√
	Connection	Fiber Optic Cable	√	√
		Connector	–	–
	Dimensions		26 x 72.7 x 13	26 x 72.7 x 13
	Housing Material		PBT	PBT
Mechanical Protection		IP66	IP66	
Approvals				

Selection Guide con't

Application Sensors

Sensor Type	Series	Page	Appearance	Advantages	Considerations
Color	S65	188		<ul style="list-style-type: none"> • High chromatic sensitivity to distinguish slight shade differences • Chromatic and C+I intensity can be set for each color • Ideal for high speed automatic packaging machines 	<ul style="list-style-type: none"> • 3-channel color sensor • C and C+I function with 10 settings • White light and RGB receiver • 3 independent outputs
	SA1J SA1J-F	192		<ul style="list-style-type: none"> • Use to detect registration marks (regardless of similarity of color) at high speed (0.3ms) • Use to distinguish between different shades of the same color • 3 LEDs (red, green and blue) provide a long life—no need to replace lamps • Use in wash-down environments • Use when long-distance range, high speed and small sensing spots are required for color sensing applications 	<ul style="list-style-type: none"> • Use the 3-color sensor for multiple outputs for sorting applications • Use the small spot version to detect small objects • Replace conventional contrast sensors with the SA1J for reliable color sensing • Use the auto-select mode to sort objects, to differentiate fine shades of the same color, or to detect objects moving to and from the sensor
Contrast	TL46	198		<ul style="list-style-type: none"> • Automatic, manual and remote settings • Wide spectrum RGB LED emissions • Fast switching frequencies 	<ul style="list-style-type: none"> • Precision light spot with RGB LEDs • NPN and PNP outputs • 1 - 5.5V analog outputs • Bargraph and 4-digit display options
Luminescence	LD46	202		<ul style="list-style-type: none"> • High sensitivity on fluorescent marks • 10 - 100mm detection distance • NPN - PNP digital output, 0 - 5V analog output • High power LED UV light source 	<ul style="list-style-type: none"> • Can detect thin marks on even highly reflective objects • Luminescent marks at longer distances can be detected • Special model for detection of labels on glass • Can detect marks on irregular surfaces such as wood
Fork/Slot	SR21	206		<ul style="list-style-type: none"> • High speed 25kHz switching frequencies • Detecting semi-transparent labels • Detecting registration marks on transparent material 	<ul style="list-style-type: none"> • 2mm slot width • 20μ sec response time

Application Sensors

Sensor Type	Series	Page	Appearance	Advantages	Considerations
Distance	S80	209		<ul style="list-style-type: none"> • Time-of-flight technology • Ideal for precise measurement of distance • Use to detect position presence of large objects from a distance 	<ul style="list-style-type: none"> • Class 2 laser emission • Direct proximity measurement 7m • PNP - NPN, 4 - 20mA output • RS485 serial interface
	SA1D	213		<ul style="list-style-type: none"> • The most reliable distance sensing, calculated using optical triangle between two points and the sensor • Analog output and digital output 	<ul style="list-style-type: none"> • Maximum analog output value corresponds to minimum sensing distance and minimum analog value corresponds to maximum distance
	MX1C	216		<ul style="list-style-type: none"> • Use in the most precise sensor applications, because of the minute size of the laser beam • Use to achieve precise positioning or alignment, visible beam is easy to aim • Analog and digital output 	<p>IMPORTANT: Always consider safety when using laser sensors. Make sure laser beam cannot inadvertently shine into the eyes of people passing by or working in the vicinity. See safety information on page 232.</p>
Area/ Dimensional	AS1	220		<ul style="list-style-type: none"> • Short response time is great for conveyor and material handling applications • Ideal for feeding and downloading lines to count objects in random positions 	<ul style="list-style-type: none"> • Area sensor with crossed beams • Operating distance is 2.1m • 0.2mm minimum detectable thickness
	DS1	224		<ul style="list-style-type: none"> • Position and dimension measurement • 150mm • 5mm resolution, 1ms response time • Operating distance up to 2.1m • 0 - 10V analog output, PNP digital output available 	<ul style="list-style-type: none"> • PNP out activated when beam is interrupted • 0 - 10V analog out proportional to dimension of object • Low response time of 1 - 3msec depending on distance dimension
Magnetic Proximity	DPRI	227		<ul style="list-style-type: none"> • Lightweight, compact design reduces mounting space requirements • Sealed reed contact • Long life and high reliability 	<ul style="list-style-type: none"> • Operating distance: 0 to 4mm

Universal Sensors
Tubular: S51 Series
M18 Photoelectric Sensors

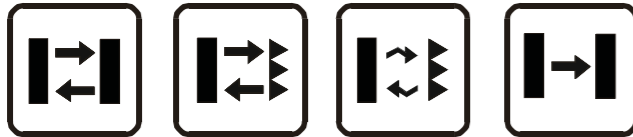

- Flat plastic housing
- Cable or M12 connection with NPN or PNP output
- Standard 3-wire connection configuration
- Selectable dark or light output

The S51 series offers a cost-effective solution in M18 photoelectric sensors, with a wide range of operating distances.

The diffuse proximity model has a 10cm fixed operating distance with a wide emission spectrum. Also available is a version with a 1 - 40cm adjustable operating distance.

Standard retro-reflective models have an operating distance up to 4m while the polarized retro-reflective models, used for reliable detection of reflective objects, are fitted with a sensitivity adjustment and have a 3.5m operating distance. The emitter and receiver models, used for longer operating distances, reach 18 meters.

The S51 series sensors, with cable or M12 connector and PNP or NPN output, provide a 3-wire connection configuration in compliance with the EN60947-5-2 standard. The normally open output is activated in light mode in proximity models and in dark mode in retro-reflective models. The output mode can be inverted using the dark/light selection input wire provided, making these extremely versatile sensors.

Dimensions (mm)

Retro-reflective A00, Short Diffused C10,
Through-beam G00

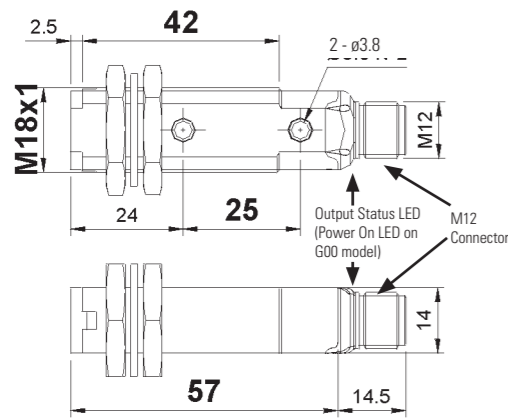

Polarized Retro-reflective B01, Long Diffused C01,
Through-beam F00

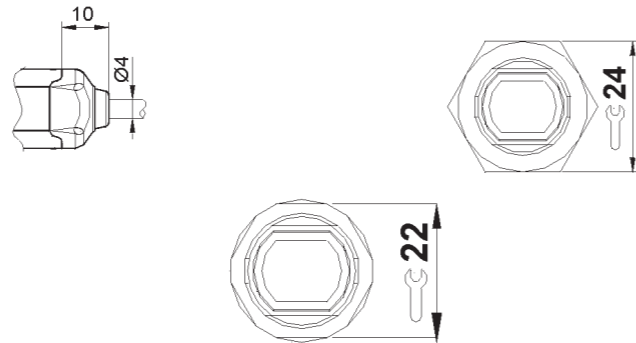
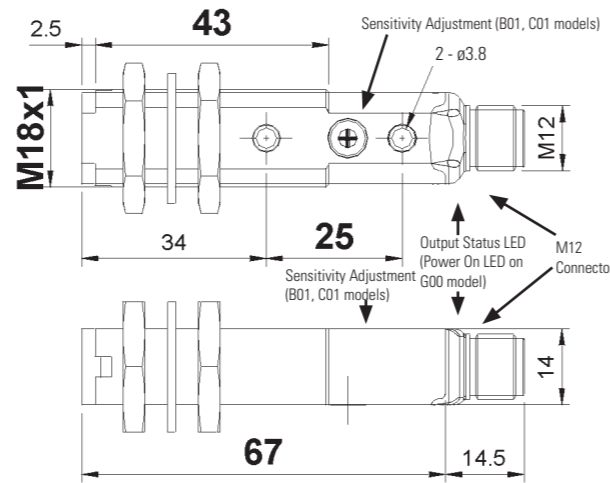

Connections

Through-beam G00

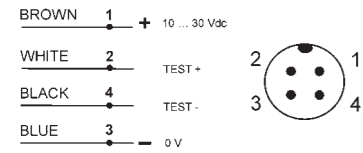

Retro-reflective A00,
Polarized Retro-reflective B01,
Long Diffused C01, Short Diffused C10,
Through-beam F00

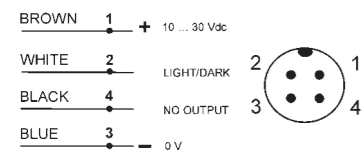

Indicators & Settings



For information on accessories,
see page 171.



Specifications

Long Diffuse Proximity Operating Distance	1 - 40cm
Short Diffuse Proximity Operating Distance	0 - 10cm
Retro-reflective Operating Distance	0.1 - 4m on R2
Polarized Retro-reflective Operating Distance	0.1 - 3m on R2
Through-beam Operating Distance	0 - 18m
Power Supply	10 - 30V DC ¹
Ripple	≤ 2 Vpp
Current Draw	≤ 35 mA
Light Emission ²	Infrared LED 880 nm Red LED 650 nm (B01 models)
Setting	Sensitivity adjustment (B01, C01 models) ³
Indicators	Yellow OUTPUT LED (excl. G00 models) Green POWER LED (G00 models)
Output Type	NPN or PNP versions
Output Current	≤ 100mA
Saturation Voltage	≤ 2V
Response Time	1ms 4ms (F00 mod.)
Switching Frequency	≤ 500Hz ≤ 120Hz (F00 mod.)
Operating Mode	dark/light selectable ⁴
Auxiliary Functions	Test + and Test - (G00 mod.) ⁵
Connection	2m ø4 mm cable ⁶ M12 4-pole connector ⁷
Electrical Protection	Class 2
Mechanical Protection	IP67
Protection Devices	A, B ⁸
Housing Material	PBT
Lens Material	PMMA
Weight	25g max.
Operating Temperature	-25 to +55°C
Storage Temperature	-25 to +70°C
Reference Standard	EN60947-5-2, UL 508

Detection Diagrams

Long Diffused C01

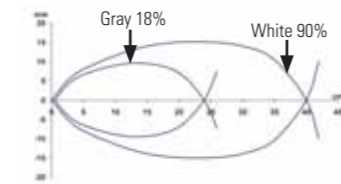

Short Diffused C10

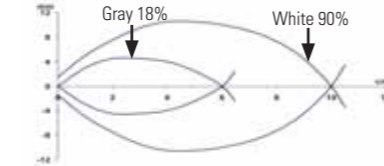

Retro-reflective A00

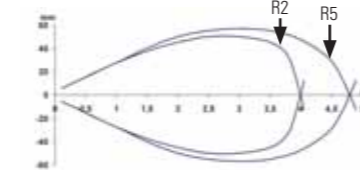

Polarized Retro-reflective B01

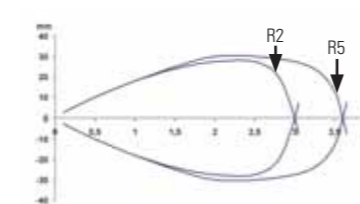

Through-beam F00/G00

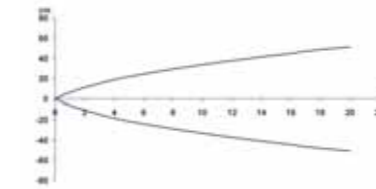

1. Limit values.
2. Average life of 100,000 hrs with $T_A = +25^\circ\text{C}$.
3. 270° single-turn sensitivity adjustment.
4. With L/D input not connected the proximity models function in the light mode and the retro-reflective and through-beam models in the dark mode; the light mode can be selected by connecting the L/D input to +V DC, the dark mode connecting it to 0V DC.
5. Emitter off with Test+ connected to +V DC and Test- to 0V DC.
6. PVC, 4 x 0.14mm²
7. M12 connector compatible with quick connection systems.
8. A - reverse polarity protection
B - overload and short-circuit protection

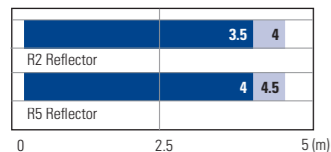
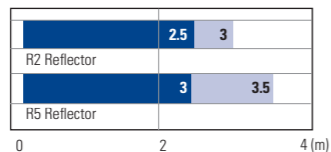
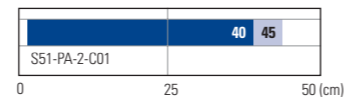
Operating Distance
Retro-reflective A00

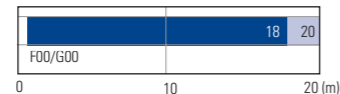
Polarized Retro-reflective B01

Long Diffused C01

Short Diffused C10

Through-beam F00/G00

■ Recommended operating distance
■ Maximum operating distance

Part Numbers

Optic Function	Connection	Output	Part Number	
	Retro-reflective	2m cable	PNP	S51-PA-2-A00-PK
	Retro-reflective	2m cable	NPN	S51-PA-2-A00-NK
	Retro-reflective	M12 connector	PNP	S51-PA-5-A00-PK
	Retro-reflective	M12 connector	NPN	S51-PA-5-A00-NK
	Polarized Retro-reflective	2m cable	PNP	S51-PA-2-B01-PK
	Polarized Retro-reflective	2m cable	NPN	S51-PA-2-B01-NK
	Polarized Retro-reflective	M12 connector	PNP	S51-PA-5-B01-PK
	Polarized Retro-reflective	M12 connector	NPN	S51-PA-5-B01-NK
	Long Diffuse Proximity	2m cable	PNP	S51-PA-2-C01-PK
	Long Diffuse Proximity	2m cable	NPN	S51-PA-2-C01-NK
	Long Diffuse Proximity	M12 connector	PNP	S51-PA-5-C01-PK
	Long Diffuse Proximity	M12 connector	NPN	S51-PA-5-C01-NK
	Short Diffuse Proximity	2m cable	PNP	S51-PA-2-C10-PK
	Short Diffuse Proximity	2m cable	NPN	S51-PA-2-C10-NK
	Short Diffuse Proximity	M12 connector	PNP	S51-PA-5-C10-PK
	Short Diffuse Proximity	M12 connector	NPN	S51-PA-5-C10-NK
	Receiver	2m cable	PNP	S51-PA-2-F00-PK
	Receiver	2m cable	NPN	S51-PA-2-F00-NK
	Receiver	M12 connector	PNP	S51-PA-5-F00-PK
	Receiver	M12 connector	NPN	S51-PA-5-F00-NK
	Emitter	2m cable	—	S51-PA-2-G00-XG
	Emitter	M12 connector	—	S51-PA-5-G00-XG

Additional models are available. Visit www.idec-ds.com for more information.

Connector Cables

Appearance	Number of Core Wires	Type & Length	Use with	Part No.
	4	Straight, 5m	S51, S60, S62	CS-A1-02-G-05
	4	Right angle, 5m		CS-A2-02-G-05

Compact: S60 Series
Multifunction Optoelectronic Sensors

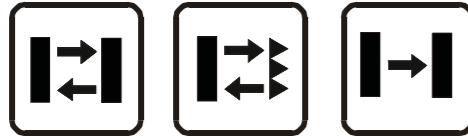

- Long operating distance
- Sensitivity adjustment
- Independent NO-NC outputs
- M12 connection with standard NPN or PNP configuration

The S60 sensors have a sensitivity adjustment that provides quick and precise setting of the switching threshold. These sensors also have an M12 connection that can be used straight or rotated to a right-angle position. All versions have NPN or PNP outputs and standard configurations conforming to the EN60947-5-2 standard.

Through-beam Sensor with Infrared Emission - 20m

A detection system with separate emitter and receiver units, allows the user to reach larger operating distances. The sensitivity adjustment, present on the receiver, allows adjustments enabling the sensor to detect objects that block, even partially, the light emission. The IR emission is modulated to avoid interference with other light sources and can be turned off to test the sensor even without an object to detect.



Dimensions (mm)

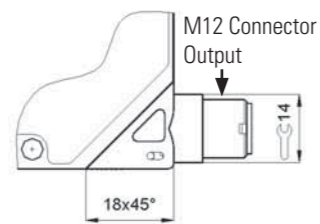
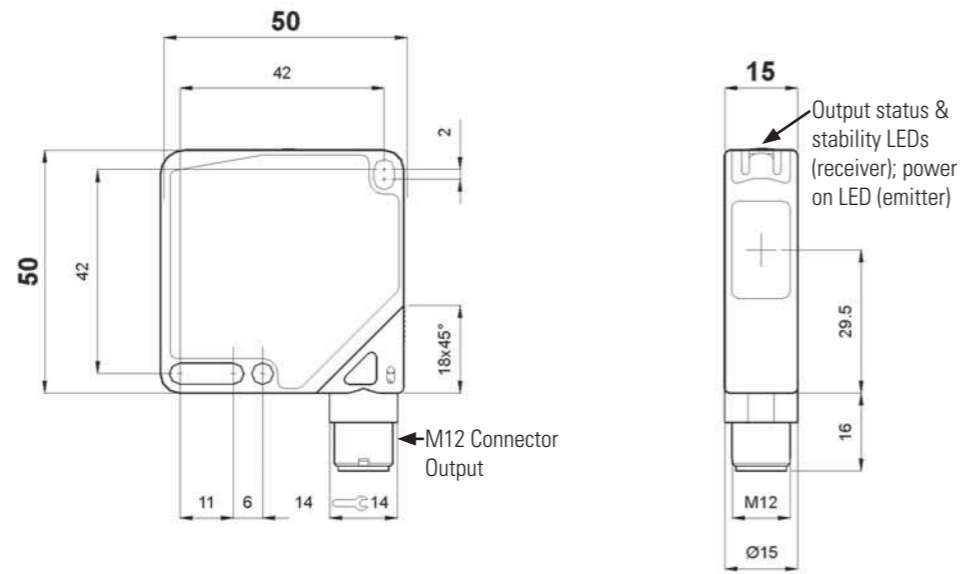

Emitter

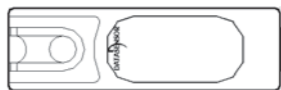

Receiver

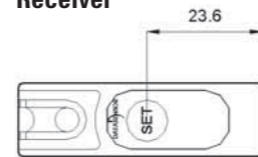

Indicators & Settings

Output status and stability LEDs (receiver); power on LED (emitter)

Receiver Sensitivity Adjustment



Single-turn sensitivity adjustment. Rotate clockwise to increase the operating distance.

Connections



Emitter

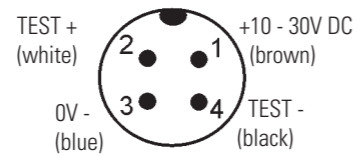

Receiver

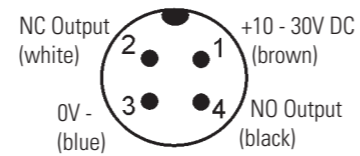

For information on accessories, see page 171.

Specifications

		S60-PA-5-F01-NN	S60-PA-5-F01-PP	S60-PA-5-G00-XG
Operating distance	0 - 20m	√	√	√
Power supply	10 - 30V DC ¹	√	√	√
Ripple	≤ 2 Vpp	√	√	√
Current Draw	≤ 35mA	√	√	√
Light emission	Infrared LED 880nm ²	–	–	√
Spot dimension	Aprox. 200mm at 4m	–	–	√
Setting	Sensitivity adjustment ³	√	√	–
Indicators	Yellow OUTPUT LED	√	√	–
	Green STABILITY LED	√	√	–
	Green POWER ON LED	–	–	√
Output type	PNP, NO and NC	–	√	–
	NPN, NO and NC	√	–	–
Output current	≤ 100mA	√	√	–
Saturation voltage	≤ 2V	√	√	–
Response time	1ms	√	√	–
Switching frequency	500Hz	√	√	–
Operating mode	dark on NO / light on NC	√	√	–
Connection	M12 4-pole connector ⁴	√	√	√
Electrical protection	Class 2	√	√	√
Mechanical protection	IP67	√	√	√
Protection devices	A, B ⁵	√	√	√
Housing material	ABS	√	√	√
Lens material	Window: PMMA ⁶	√	√	√
Weight	40g max.	√	√	√
Operating temperature	-25 to +55°C	√	√	√
Storage temperature	-25 to +70°C	√	√	√
Reference standard	EN60947-5-2, UL508	√	√	√



Additional models are available. Visit www.idec-ds.com for more information.

1. Limit values
2. Average life of 100,000 hrs with T_A = +25°C
3. 270° sensitivity adjustment

4. Connector can be locked in two positions
5. A - reverse polarity protection
B - overload and short-circuit protection on receiver outputs
6. Internal lens - Polycarbonate

Operating Distance

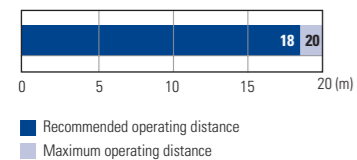

Detection Diagrams

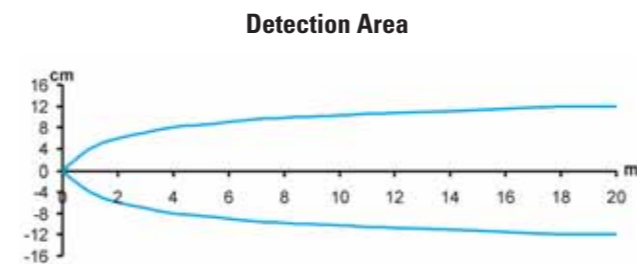
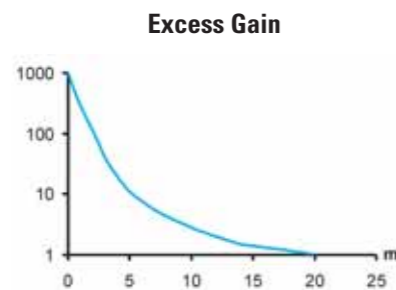

Polarized Retro-reflective Sensor with Red Emission - 8m

With retro-reflective sensors, the object is detected when it interrupts the light beam generated between the sensor and its associated reflector. High-polarization optic filters also allow reliable detection of very shiny objects, such as mirrored surfaces.



Dimensions (mm)

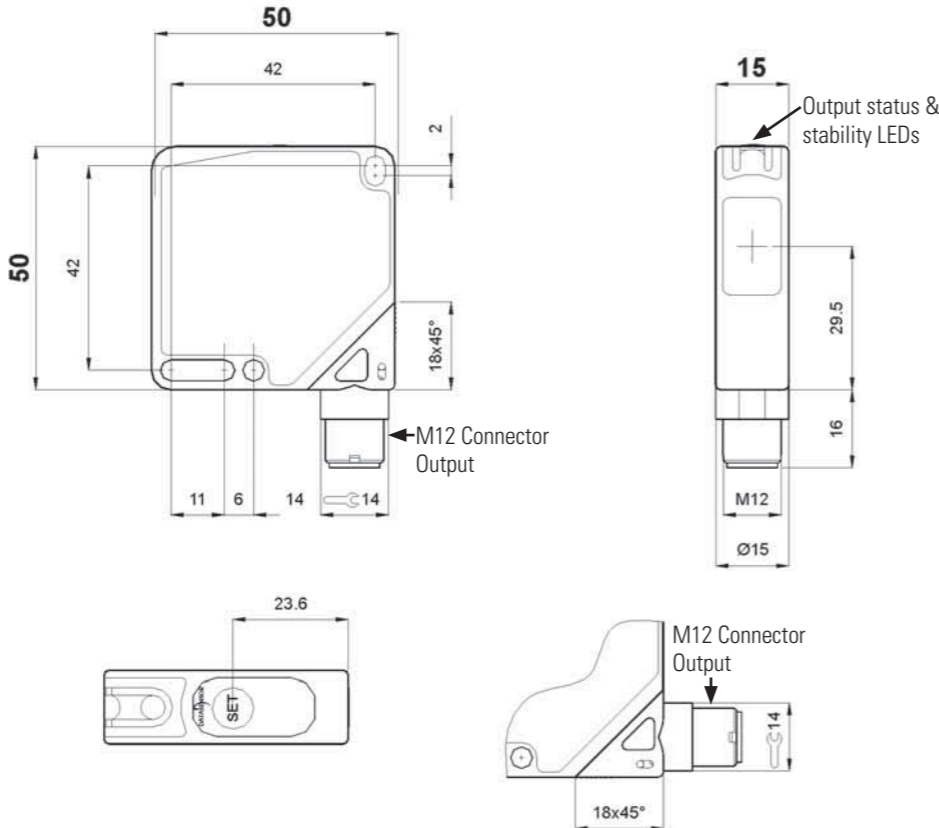

Indicators & Settings

Output status and stability LEDs Sensitivity Adjustment



Single-turn sensitivity adjustment. Rotate clockwise to increase the operating distance.

Connections

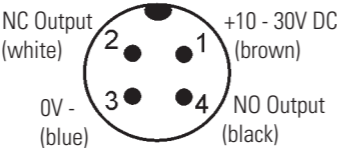

For information on accessories, see page 171.

Specifications

		S60-PA-5-B01-NN	S60-PA-5-B01-PP
Operating Distance	0.1 - 8m (on R5)	√	√
Power Supply	10 - 30V DC ¹	√	√
Ripple	≤ 2Vpp	√	√
Current Draw	≤ 40mA	√	√
Light Emission	red LED 660nm ²	√	√
Spot Dimension	aprox. 90mm at 3m	√	√
Setting	sensitivity adjustment ³	√	√
Indicators	yellow OUTPUT LED	√	√
	green STABILITY LED	√	√
Output Type	PNP, NO and NC	–	√
	NPN, NO and NC	√	–
Output Current	≤ 100mA	√	√
Saturation Voltage	≤ 2V	√	√
Response Time	500μs	√	√
Switching Frequency	1kHz	√	√
Operating Mode	dark on NO / light on NC	√	√
Connection	M12 4-pole connector ⁴	√	√
Electrical Protection	class 2	√	√
Mechanical Protection	IP67	√	√
Protection Devices	A, B ⁵	√	√
Housing Material	ABS	√	√
Lens Material	Window: PMMA ⁶	√	√
Weight	40g max.	√	√
Operating Temperature	-25 to +55°C	√	√
Storage Temperature	-25 to +70°C	√	√
Reference Standard	EN60947-5-2, UL508	√	√



Additional models are available. Visit www.idec-ds.com for more information.

1. Limit values
2. Average life of 100,000 hrs with T_a = +25 °C
3. 270° sensitivity adjustment

4. Connector can be locked in two positions
5. A - reverse polarity protection
B - overload and short-circuit protection on outputs
6. Internal lens - Polycarbonate

Operating Distance

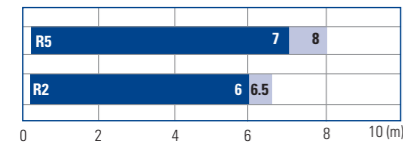

■ Recommended operating distance
■ Maximum operating distance

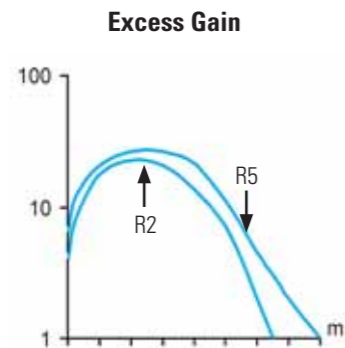

Detection Diagrams

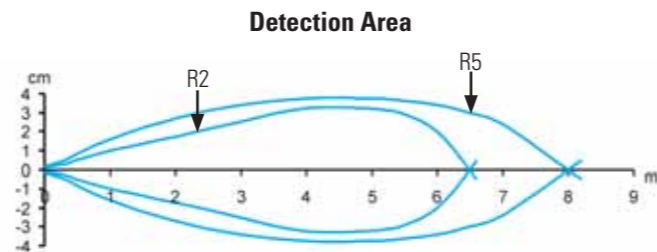

Coaxial Polarized Retro-reflective Sensor for Transparent Objects - 2m

The high sensitivity and reduced hysteresis of this retro-reflective sensor allows detection of the slightest light emission, even through transparent objects, such as glass, PET bottles or plastic film sheets for packaging. The use of polarization filters helps to avoid inaccurate switching on shiny surfaces and coaxial optics improve the detection precision of the entire operating range.



Dimensions (mm)

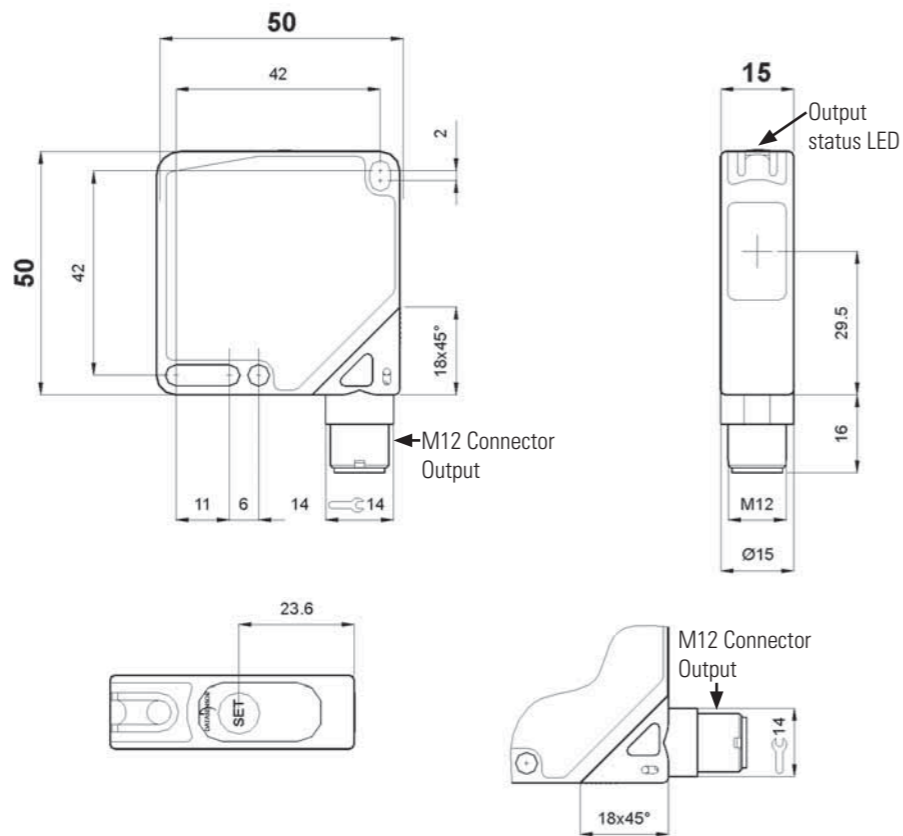

Indicators & Settings

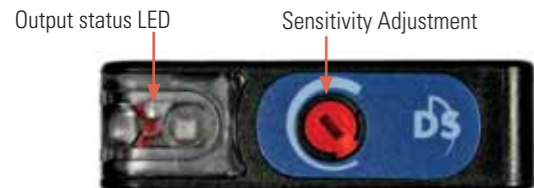

Single-turn sensitivity adjustment. Rotate clockwise to increase the operating distance.

Connections

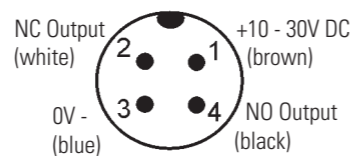

For information on accessories, see page 171.

Specifications

		S60-PA-5-T51-NN	S60-PA-5-T51-PP
Operating Distance	0 - 2m (on R5)	√	√
Power Supply	10 - 30V DC ¹	√	√
Ripple	≤ 2Vpp	√	√
Current Draw	≤ 40mA	√	√
Light Emission	Red LED 660nm ²	√	√
Spot Dimension	Aprox. 50mm at 1.5m	√	√
Setting	Sensitivity adjustment ³	√	√
Indicators	Yellow OUTPUT LED	√	√
Output Type	PNP, NO and NC	–	√
	NPN, NO and NC	√	–
Output Current	≤ 100mA	√	√
Saturation Voltage	≤ 2V	√	√
Response Time	500µs	√	√
Switching Frequency	1kHz	√	√
Operating Mode	dark on NO / light on NC	√	√
Connection	M12 4-pole connector ⁴	√	√
Electrical Protection	Class 2	√	√
Mechanical Protection	IP67	√	√
Protection Devices	A, B ⁵	√	√
Housing Material	ABS	√	√
Lens Material	Window in glass (tilted anti-reflection) ⁶	√	√
Weight	40g max.	√	√
Operating Temperature	-25 to +55°C	√	√
Storage Temperature	-25 to +70°C	√	√
Reference Standard	EN60947-5-2, UL508	√	√



Additional models are available. Visit www.idec-ds.com for more information.

1. Limit values
2. Average life of 100,000 hrs with T_a = +25 °C
3. 270° sensitivity adjustment

4. Connector can be locked in two positions

5. A - reverse polarity protection
B - overload and short-circuit protection on outputs
6. Internal lens - glass

Operating Distance

R5	1.7	2
R2	1.5	1.7

■ Recommended operating distance
■ Maximum operating distance

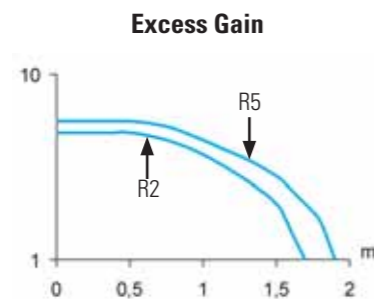

Detection Diagrams

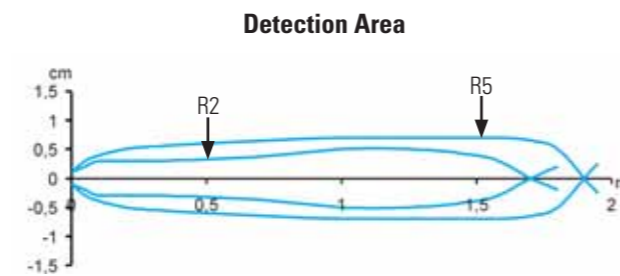

Diffuse Proximity Sensor - 100cm

This diffuse proximity sensor provides a reliable, simple and cost-effective solution for the direct detection of any object within the operating distance. The sensitivity adjustment is used to set the sensing distance easily and accurately. The visible red emission allows alignment of the sensor or object in short operating distances.



Dimensions (mm)

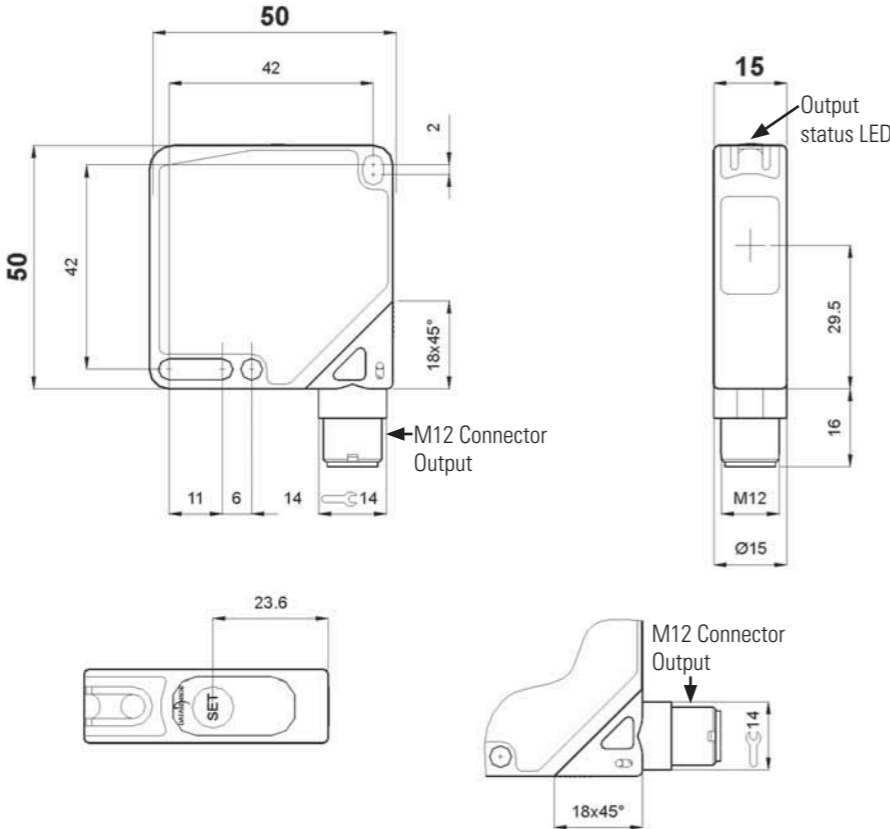

Indicators & Settings

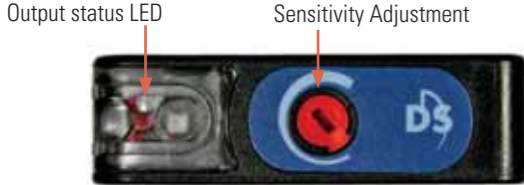

Single-turn sensitivity adjustment. Rotate clockwise to increase the operating distance.

Connections

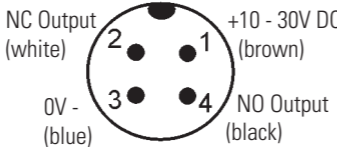

For information on accessories, see page 171.

Specifications

		S60-PA-5-C01-NN	S60-PA-5-C01-PP
Operating Distance	0 - 100cm	√	√
Power Supply	10 - 30V DC ¹	√	√
Ripple	≤ 2Vpp	√	√
Current Draw	≤ 40mA	√	√
Light Emission	Red LED 660nm ²	√	√
Spot Dimension	Approx. 50mm at 90cm	√	√
Setting	Sensitivity adjustment ³	√	√
Indicators	Yellow OUTPUT LED	√	√
	Green STABILITY LED	√	√
Output Type	PNP, NO and NC	–	√
	NPN, NO and NC	√	–
Output Current	≤ 100mA	√	√
Saturation Voltage	≤ 2V	√	√
Response Time	1ms	√	√
Switching Frequency	500Hz	√	√
Operating Mode	Light on NO / dark on NC	√	√
Connection	M12 4-pole connector ⁴	√	√
Electrical Protection	Class 2	√	√
Mechanical Protection	IP67	√	√
Protection Devices	A, B ⁵	√	√
Housing Material	ABS	√	√
Lens Material	Window: PMMA ⁶	√	√
Weight	40g max.	√	√
Operating Temperature	-25 to +55°C	√	√
Storage Temperature	-25 to +70°C	√	√
Reference Standard	EN60947-5-2, UL508	√	√



Additional models are available. Visit www.idec-ds.com for more information.

1. Limit values
2. Average life of 100,000 hrs with T_a = +25 °C
3. 270° sensitivity adjustment

4. Connector can be locked in two positions
5. A - reverse polarity protection
B - overload and short-circuit protection on outputs
6. Internal lens - polycarbonate

Operating Distance

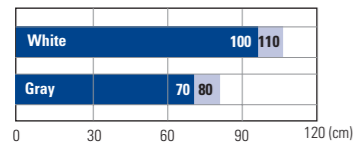

Recommended operating distance
 Maximum operating distance

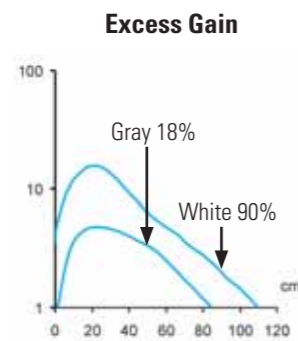

Detection Diagrams

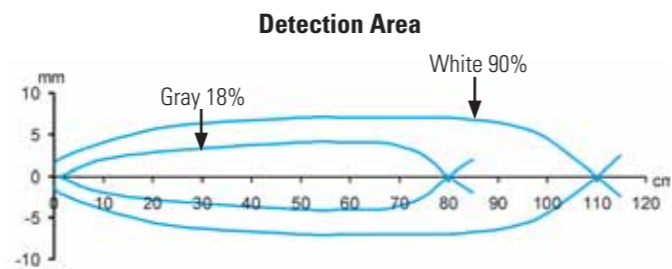

Long Diffuse Proximity - 200cm

This model of diffuse proximity sensor offers a long operating distance for direct detection of objects without the use of separate reflectors or receivers. The detection distance can be set using the sensitivity adjustment. The green stability LED indicates that the received signal is higher than the minimum signal for output switching.



Dimensions (mm)

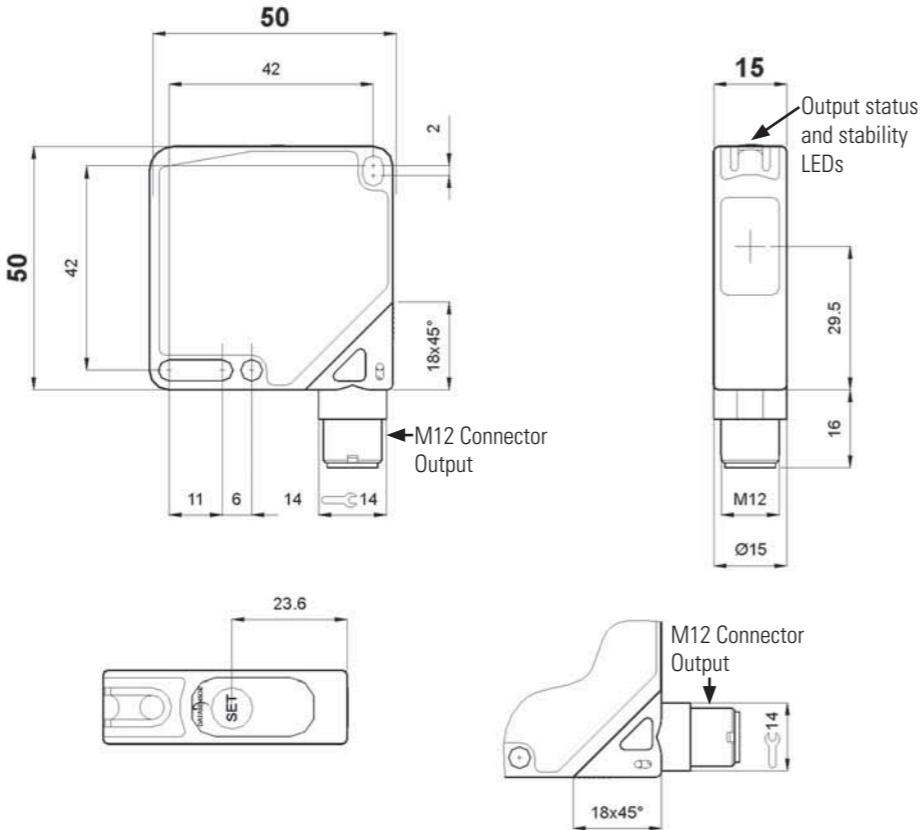

Indicators & Settings

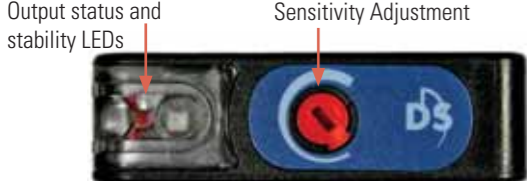

Single-turn sensitivity adjustment. Rotate clockwise to increase the operating distance.

Connections

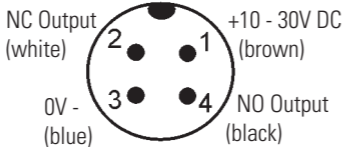

For information on accessories, see page 171.

Specifications

		S60-PA-5-C11-NN	S60-PA-5-C11-PP
Operating Distance	5 - 200cm	√	√
Power Supply	10 - 30VDC ¹	√	√
Ripple	≤ 2 Vpp	√	√
Current Draw	≤ 40mA	√	√
Light Emission	Infrared LED 880nm ²	√	√
Spot Dimension	Approx. 250mm at 1m	√	√
Setting	Sensitivity adjustment ³	√	√
Indicators	Yellow OUTPUT LED	√	√
	Green STABILITY LED	√	√
Output Type	PNP, NO and NC	–	√
	NPN, NO and NC	√	–
Output Current	≤ 100mA	√	√
Saturation Voltage	≤ 2V	√	√
Response Time	1ms	√	√
Switching Frequency	500Hz	√	√
Operating Mode	Light on NO / dark on NC	√	√
Connection	M12 4-pole connector ⁴	√	√
Electrical Protection	Class 2	√	√
Mechanical Protection	IP67	√	√
Protection Devices	A, B ⁵	√	√
Housing Material	ABS	√	√
Lens Material	Window: PMMA ⁶	√	√
Weight	40g max.	√	√
Operating Temperature	-25 to +55°C	√	√
Storage Temperature	-25 to +70°C	√	√
Reference Standard	EN60947-5-2, UL508	√	√



Additional models are available. Visit www.idec-ds.com for more information.

- Limit values
- Average life of 100,000 hrs with $T_A = +25^\circ\text{C}$
- 270° sensitivity adjustment

- Connector can be locked in two positions
- A - reverse polarity protection
B - overload and short-circuit protection on outputs
- Internal lens - polycarbonate

Operating Distance

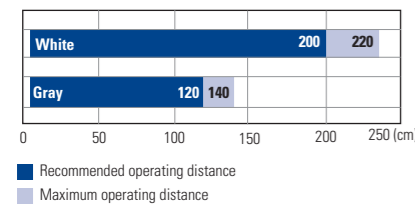

Excess Gain

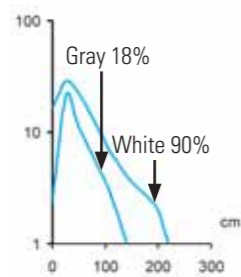

Detection Diagrams

Detection Area

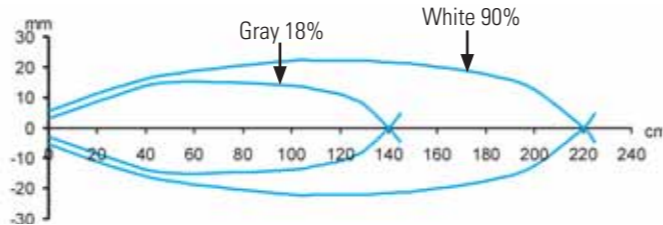

Technological Advantages

The S60 series establishes a new standard in compact 50 x 50mm photoelectric sensors, offering a complete family of optical functions within a 15mm housing width.

The standard dimensions, reduced housing width, and the multi-hole mounting system make the S60 series superior to the majority of compact sensors present on the market.

The models are available with M12 connectors, NPN or PNP output, and conform to EN60947-5-2 European standards.

The M12 connector can be easily rotated to 90° and can be locked in straight or right-angle positions compared to the optic axis. The cable emerges at 45° and can be bent almost 360°. These characteristics allow the sensor to be easily mounted on any side and at any angle.

The S60 series are available in through-beam, polarized retro-reflective and diffuse proximity. The polarized retro-reflective model is available with a coaxial optic version with the emitter optic axis coinciding with the receiver. This offers superior detection axis precision and eliminates the blind zone near the sensor.

**SMT Chip-size for Electronic Miniaturization
Gains More Space for the Optics**

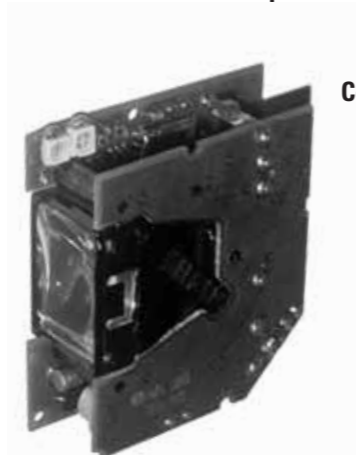

Coaxial Optics

**Complete External Shield for
High Electromagnetic Compatibility**

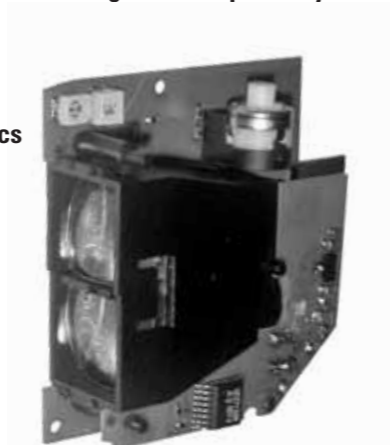

Biaxial Optics

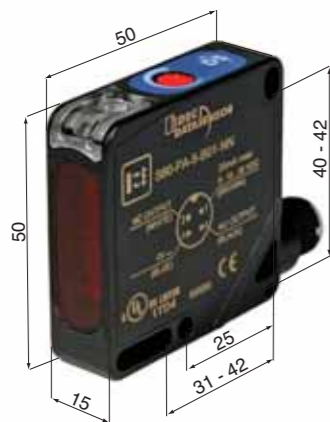

**Compact Photoelectric Sensors
Standard 50 x 50 x 15mm**



Coaxial optics are also available in the polarized retro-reflective model for detection of transparent objects. This increases the performance of the optical function and its immunity to object movement inside the detection area.

The range and switching threshold output can be selected from 50 - 150mm, with a ± 1mm precision; direct or inverse proportionality and light or dark operating modes can also be selected.

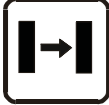
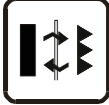

Part Numbers

Function	Connection	Output	Part Number	Page Number	
	Polarized Retro-reflective	M12 connector	NPN	S60-PA-5-B01-NN	140
	Polarized Retro-reflective	M12 connector	PNP	S60-PA-5-B01-PP	
	Diffuse Proximity (100cm)	M12 connector	NPN	S60-PA-5-C01-NN	144
	Diffuse Proximity (100cm)	M12 connector	PNP	S60-PA-5-C01-PP	
	Long Diffuse Proximity (200cm)	M12 connector	NPN	S60-PA-5-C11-NN	146
	Long Diffuse Proximity (200cm)	M12 connector	PNP	S60-PA-5-C11-PP	
	Receiver	M12 connector	NPN	S60-PA-5-F01-NN	138
	Receiver	M12 connector	PNP	S60-PA-5-F01-PP	
	Emitter	M12 connector	-	S60-PA-5-G00-XG	
	Retro-reflective for transparent objects	M12 connector	NPN	S60-PA-5-T51-NN	142
	Retro-reflective for transparent objects	M12 connector	PNP	S60-PA-5-T51-PP	



Additional models are available. Visit www.idec-ds.com for more information.

Connector Cables

Appearance	Number of Core Wires	Type & Length	Use with	Part No.
	4	Straight, 5m	S51, S60, S62	CS-A1-02-G-05
	4	Right angle, 5m		CS-A2-02-G-05

Compact: S62 Series
High-performance Sensors

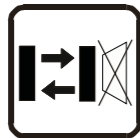

- High-resolution sensors with LED or Laser emission
- Background suppression models ranging from 30 - 350mm



- Polarized retro-reflective with operating distances up to .3 - 20m
- Sturdy ABS housing with compact 18 x 50 x 50mm dimensions



- NPN or PNP double output with standard NO-NC configuration

The S62 series, in a 18 x 50 x 50mm compact plastic housing, offers maximum performance for industrial automation applications.

The background suppression proximity models can detect up to 300mm using visible red LED emission, or up to 2000mm with infrared emission. The operating distance can be adjusted through a precise multi-turn mechanical regulation of optical triangulation to obtain maximum immunity against color differences of the detected object or of the background, even if very reflective.

A visible red laser is available with a 50-350mm background suppression distance and a polarized retro-reflective range reaching more than 20m.

These Laser sensors are characterized by a very small light spot, as well as a fast response time for excellent detection repeatability, even of very small objects or movement.

The background suppression proximity sensor can be set precisely over the limit that the object is not detected, even with subtle differences between objects with material or color variances.

Threshold switching adjustment is easy and more precise due to the multi-turn mechanical sensitivity adjustment and numerical scale.

The polarized retro-reflective model detects very shiny objects even with mirrored surfaces.

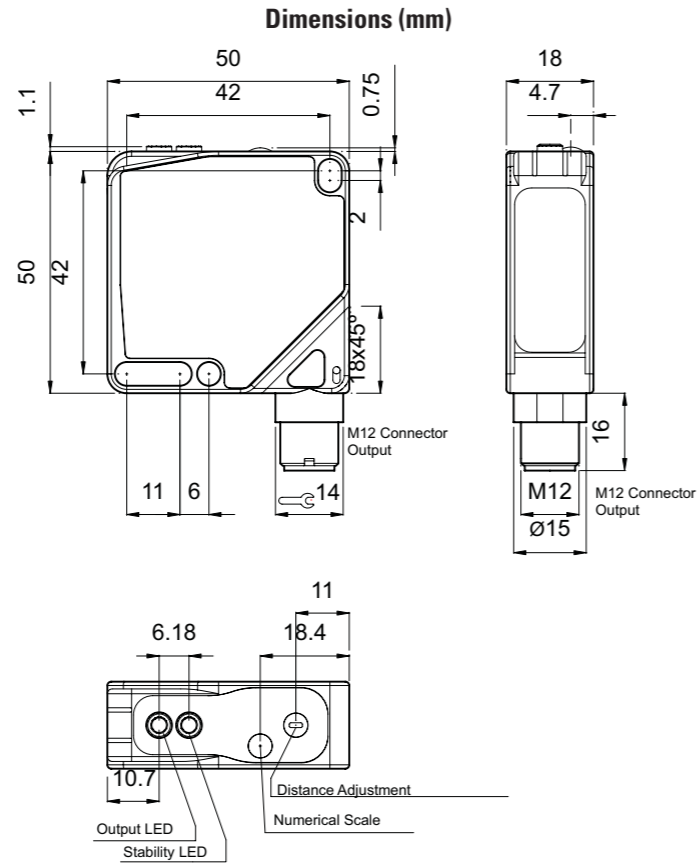

Indicators & Settings

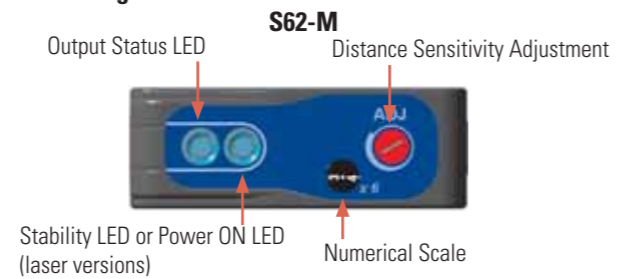
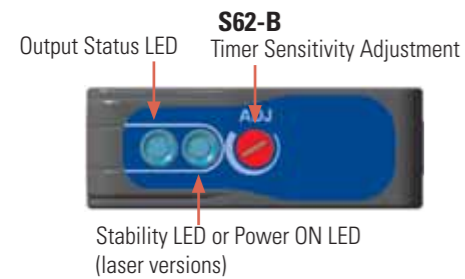

Connection

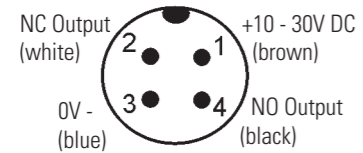

For information on accessories, see page 171.

Emission Type

The ability of background suppression sensors to detect very small variances in contrast (between light and dark areas) allows detection of the presence or absence of a dark-colored target, even on a light-colored, very reflective background. However, if the target is much smaller than the light spot or smaller than the background area, detection can be difficult because of either low resolution or a “cross-eyed” effect (excessive light reflected by the background).

The narrow light beam of the S62 Laser background suppression sensor is the right solution for good resolution and to avoid a “cross-eyed” effect. It can detect the smallest objects or their minimal movements, even with large and/or reflective background areas.

The Laser polarized retro-reflective sensor of the S62 series, as well as increasing maximum operating distance, offers improved detection resolution due to smaller dimensions of the light beam with respect to the LED emission beam.

The minimum detectable dimension corresponds to the emission beam diameter at the detection distance. Using reflectors (0.8mm microcubes) will help to achieve maximum resolution. For example, the R8 is suitable for short distances up to 2m, while the R7 or R20 models are for distances up to 22m.

LED Emission

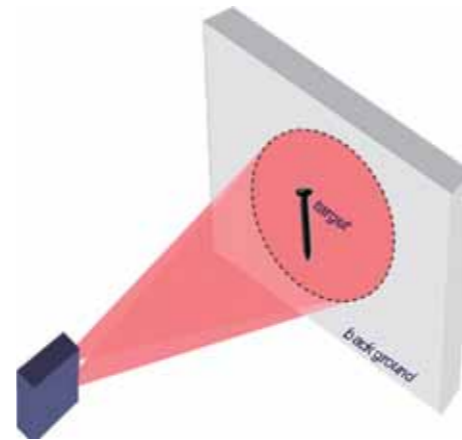

Laser Emission

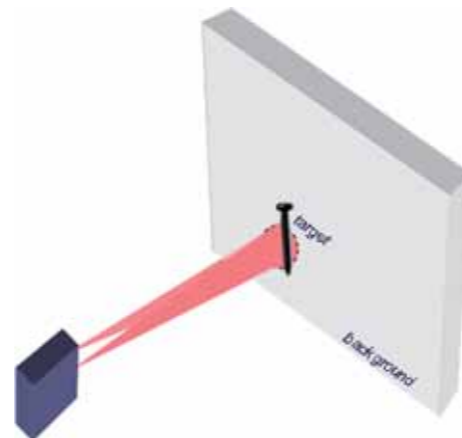

Specifications for LED Emission Models

		S62-PA-5-M01	S62-PA-5-M11	S62-PA-5-M21	S62-PA-5-M31
Operating Distance	30 - 300mm	√	–	–	–
	60 - 600mm	–	√	–	–
	60 - 1200mm	–	–	√	–
	200 - 2000mm	–	–	–	√
Power Supply	10 - 30V DC ¹	√	√	√	√
Ripple	≤ 2 Vpp	√	√	√	√
Current Draw	≤ 40mA	√	√	√	√
Light Emission ²	Red LED 660nm	√	–	–	–
	Infrared LED 880nm	–	√	√	√
Spot Dimension	6 x 6mm at 200mm	√	–	–	–
	15 x 15mm at 400mm	–	√	√	–
	200 x 200 at 2000mm	–	–	–	√
Setting	6-turn sensitivity adjustment	√	√	√	√
Indicators	Yellow OUTPUT LED	√	√	√	√
	Green STABILITY LED	√	√	√	√
Output Type	PNP, NO and NC (-PP suffix)	√	√	√	√
	NPN, NO and NC (-NN suffix)	√	√	√	√
Output Current	≤ 100mA	√	√	√	√
Saturation Voltage	≤ 2V	√	√	√	√
Response Time	500μs	√	√	–	–
	1ms	–	–	√	–
	1.5ms	–	–	–	√
Max. Switching Frequency	330Hz	–	–	–	√
	500Hz	–	–	√	–
	1kHz	√	√	–	–
Operating Mode	Light on NO / dark on NC	√	√	√	√
Connection	M12 4-pole connector ³	√	√	√	√
Mechanical Protection	IP67	√	√	√	√
Protection Devices	A, B ⁴	√	√	√	√
Housing Material	ABS	√	√	√	√
Lens Material	Window: PMMA	√	√	√	√
	Lenses: PC	√	√	√	√
Weight	40g max.	√	√	√	√
Operating Temperature	-10 to +55°C	√	√	√	√
Storage Temperature	-20 to +70°C	√	√	√	√
Reference Standard	EN60947-5-2, UL508	√	√	√	√



1. Limit values
2. Average life of 100,000 hrs with T_a = +25 °C
3. Connector can be locked in two positions
4. A - reverse polarity protection
B - overload and short-circuit protection



Detection Diagrams for Models with LED Emission

30 - 300mm Background Suppression

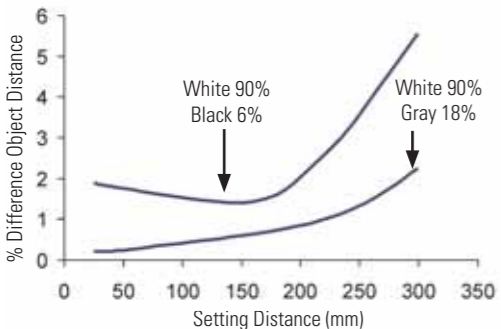

60 - 600mm Background Suppression

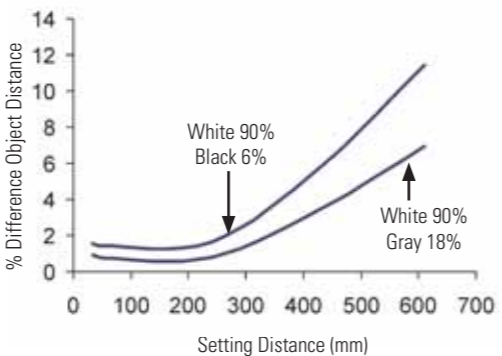

60 - 1200mm Background Suppression

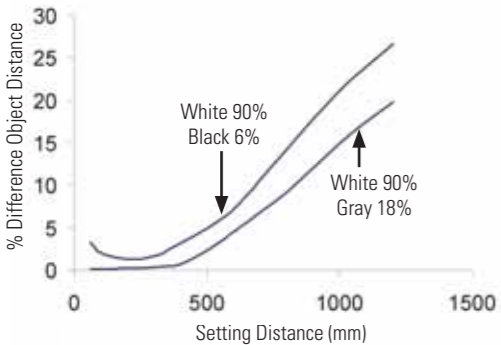

200 - 2000mm Background Suppression

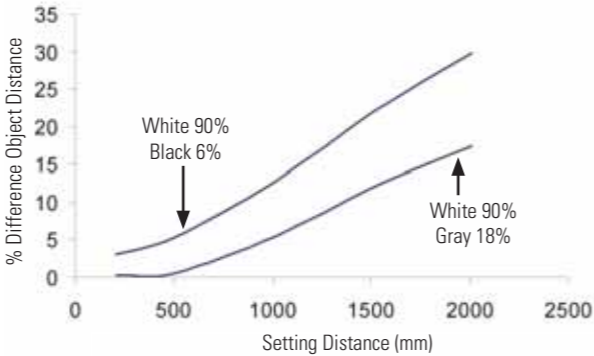

Operating Distance

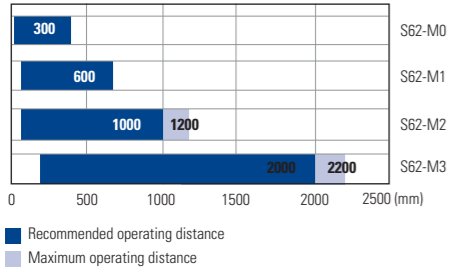

Specifications for Laser Emission Models

		S62-PL-5-B01	S62-PL-5-M11
Polarized Retro-reflective Operating Distance	0.3 - 20m (using R2, refer to table on next page)	√	–
Background Suppr. Operating Distance	50 - 350mm	–	√
Power Supply	10 - 30V DC ¹	√	√
Ripple	≤ 2 Vpp	√	√
Current Draw	≤ 30mA	√	√
Light Emission	Red Laser 645 - 665nm ²	√	√
Spot Dimension	0.5mm at 0.5m ≤ 0.4mm at 150mm	√ –	√
Setting	270 degree sensitivity adjustment 6-turn sensitivity adjustment	√ –	– √
Indicators	Yellow OUTPUT LED	√	√
Output Type	Green POWER ON LED PNP, NO and NC (-PP suffix) NPN, NO and NC (-NN suffix)	√ √ √	√ √ √
Output Current	≤ 100mA	√	√
Saturation Voltage	≤ 2V	√	√
Response Time	200μs	√	√
Max. Switching Frequency	2.5 kHz	√	√
Operating Mode	Light on NO / dark on NC Light on NC / dark on NO	– √	√ –
Connection	M12 4-pole connector ³	√	√
Mechanical Protection	IP67	√	√
Protection Devices	A, B ⁴	√	√
Housing Material	ABS	√	√
Lens Material	Window: PMMA Lenses: PC / PMMA	√ √	√ √
Weight	40g max.	√	√
Operating Temperature	-10 to +55°C	√	√
Storage Temperature	-20 to +70°C	√	√
Reference Standard	EN60947-5-2, UL508 EN60825-1, CDRH21 CFR 1040.10	√ √	√ √



Additional models are available. Visit www.idec-ds.com for more information.

1. Limit values
2. Average life of 100,000 hrs with T_a = +25 °C
3. Connector can be locked in two positions
4. A - reverse polarity protection
B - overload and short-circuit protection on outputs



Detection Diagrams for Models with Laser Emission

Laser Polarized Retro-reflective

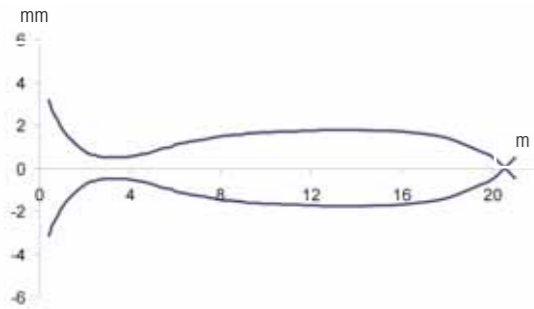

Light Spot Dimension - Laser Polarized Retro-reflective

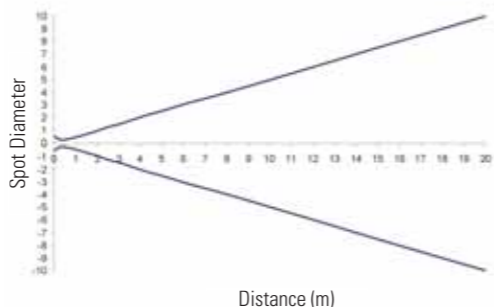

50 - 350mm Laser Background Suppression

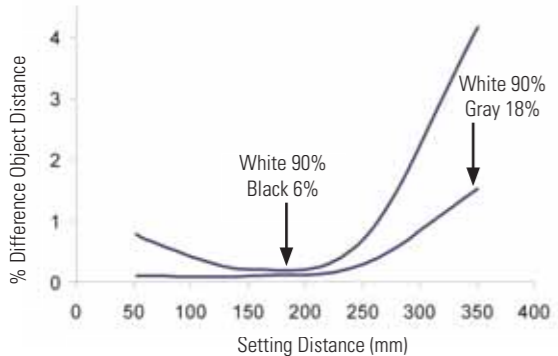

Operating Distance

Sensor Operating Distance (mm)

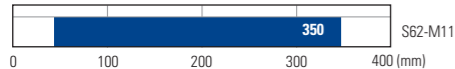



Reflector Operating Distance (m)

R1	R2	R6	R7 / R20	R8
0.3 - 16	0.3 - 20	0.4 - 22	0.3 - 22	0.2 - 2

■ Recommended operating distance
 ■ Maximum operating distance





Part Numbers

Optic Function	Connection	Output	Part Number	
	300mm Background Suppression	M12 connector	PNP	S62-PA-5-M01-PP
	300mm Background Suppression	M12 connector	NPN	S62-PA-5-M01-NN
	600mm Background Suppression	M12 connector	PNP	S62-PA-5-M11-PP
	600mm Background Suppression	M12 connector	NPN	S62-PA-5-M11-NN
	1200mm Background Suppression	M12 connector	PNP	S62-PA-5-M21-PP
	1200mm Background Suppression	M12 connector	NPN	S62-PA-5-M21-NN
	2000mm Background Suppression	M12 connector	NPN	S62-PA-5-M31-NN
	2000mm Background Suppression	M12 connector	PNP	S62-PA-5-M31-PP
 Class 2	20m Laser Polarized Retro-reflective	M12 connector	NPN	S62-PL-5-B01-NN
	20m Laser Polarized Retro-reflective	M12 connector	PNP	S62-PL-5-B01-PP
 Class 2	350mm Laser Background Suppression	M12 connector	NPN	S62-PL-5-M11-NN
	350mm Laser Background Suppression	M12 connector	PNP	S62-PL-5-M11-PP



Additional models are available. Visit www.idec-ds.com for more information.

Connector Cables

Appearance	Number of Core Wires	Type & Length	Use with	Part No.
	4	Straight, 5m	S51, S60, S62	CS-A1-02-G-05
	4	Right angle, 5m		CS-A2-02-G-05

Miniature Photoelectric: SA1E
Simple, Compact Design for Worldwide Usage

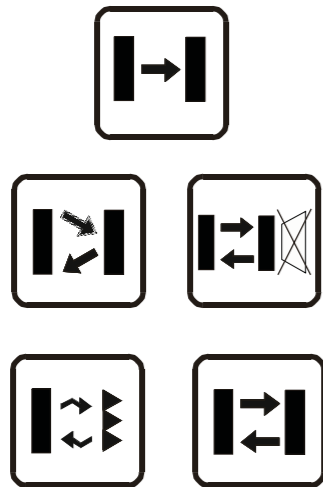

- Six sensing methods
- 1m proximity, 15cm with narrow beam
- 4m polarized retro-reflective
- 15m through-beam
- Standard 3 wire output configuration
- Cable and M8 connector types available
- NPN output, PNP output, Light On, Dark On options
- Long sensing ranges, high-speed response
- CE marked, UL Listed

Ensuring the accurate recognition of target objects is critical for many control systems. Reliable object recognition means fewer false alarms, increased productivity and less product rejection. When selecting sensors for your applications, the most important criteria to consider are: reliability, durability and ruggedness.

The miniature SA1E photoelectric sensors incorporate all of these features in a compact housing, and are also easy-to-install and competitively priced. All SA1E photoelectric sensors are IP67 rated, UL/c-UL listed and CE marked. A choice of NPN or PNP outputs are available, as well as a choice of Dark ON or Light ON operation modes.

Dimensions (mm)

Cable Models

Connector Models

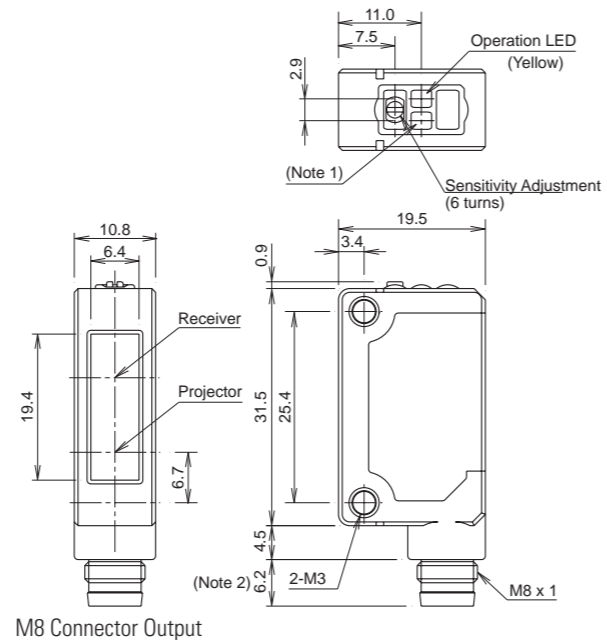
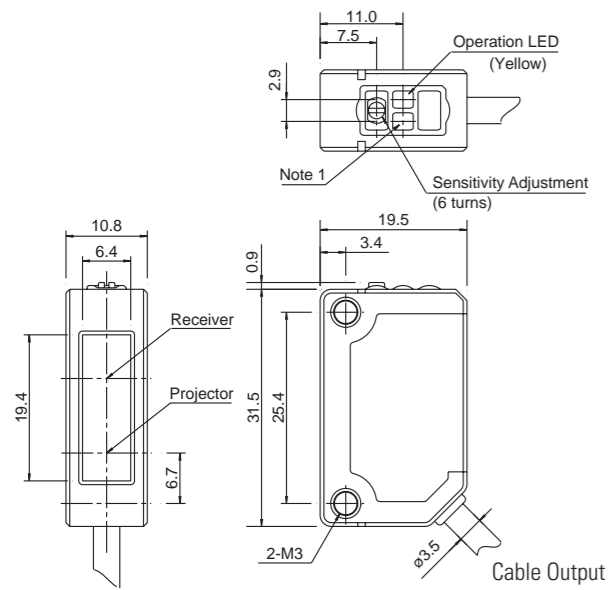

Note 1: Stable LED is not provided on the background suppression type.
 Note 2: The connector length is 18mm when a right-angle connector cable (SA9Z-CM8K-4L*) is attached.

Indicators & Settings

Connections

SA1E-B, SA1E-D, SA1E-N, SA1E-P

SA1E-T

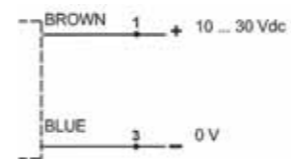
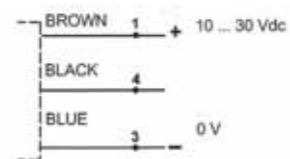
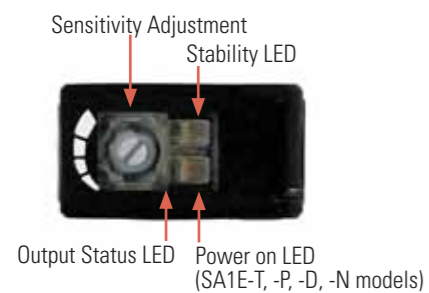

M8 Connector



For information on accessories, see page 171.

Detection Diagrams

Through-beam SA1E-T

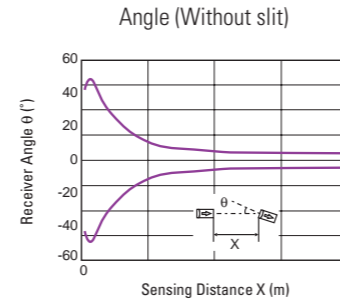
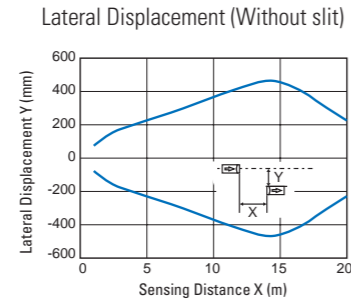
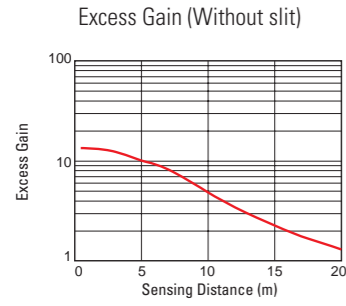

Polarized Retro-reflective SA1E-P

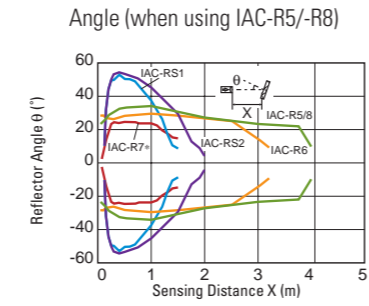
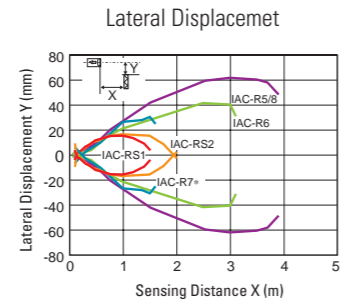
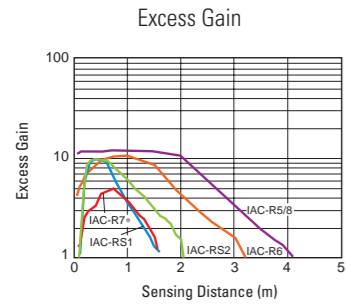

Background Suppression SA1E-B

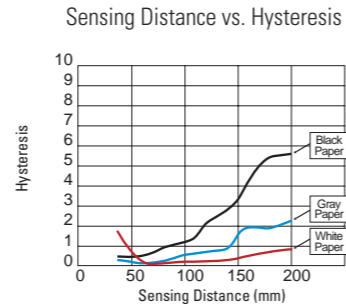
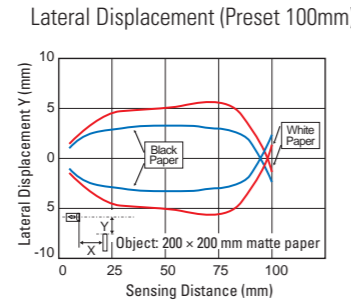
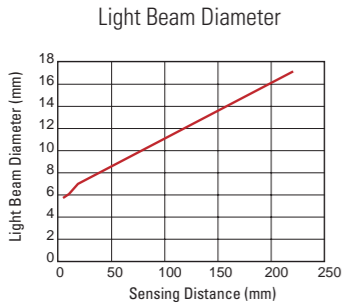

Convergent SA1E-G

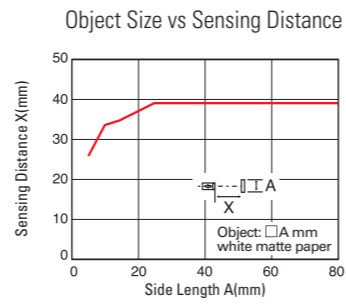
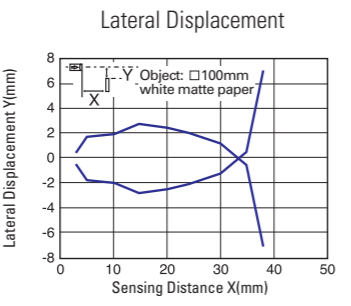
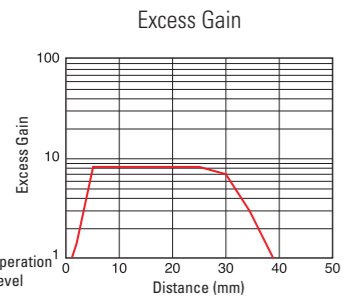

Diffuse-reflective SA1E-D

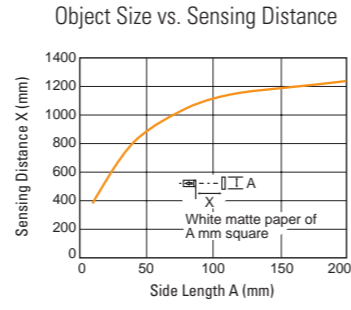
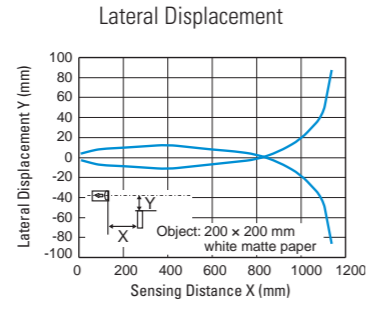
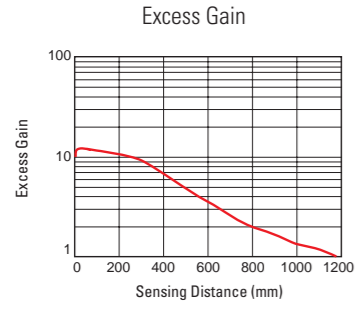

Small-beam Reflective SA1E-N

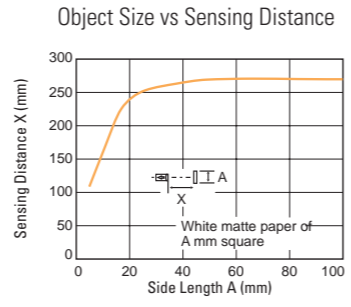
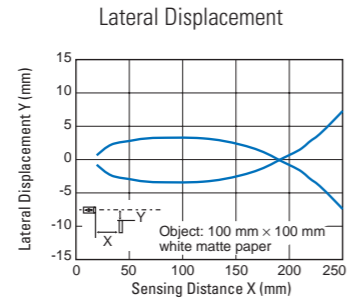
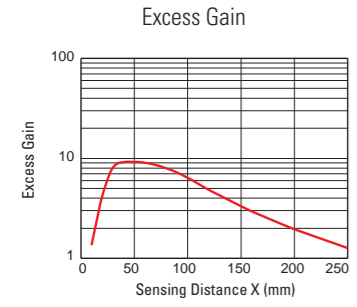

Output Circuit & Wiring Diagrams

NPN Output

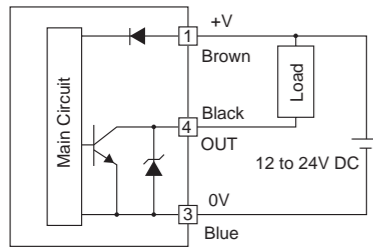

PNP Output

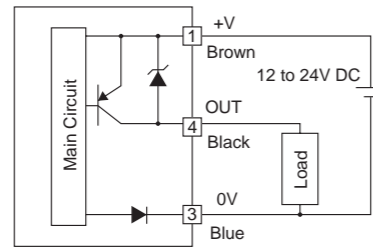

Through-beam Emitter

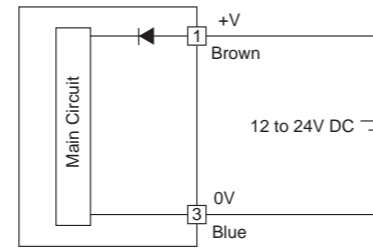

Connector Pin Assignment

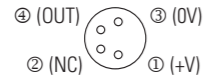

Connector Pin Assignment

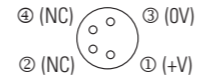





Specifications

		SA1E-P**2M	SA1E-N**2M	SA1E-D**2M	SA1E-T**2M	SA1E-B**2M	SA1E-G**2M	SA1E-P**C	SA1E-N**C	SA1E-D**C	SA1E-T**C	SA1E-B**C	SA1E-G**C
Narrow Beam Proximity Operating Distance	50 - 150mm	-	√	-	-	-	-	-	√	-	-	-	-
Diffuse Proximity Operating Distance	0 - 700mm	-	-	√	-	-	-	-	-	√	-	-	-
Polarized Retro-reflective Operating Distance	0.08 - 3m (on R5)	√	-	-	-	-	-	√	-	-	-	-	-
Through-beam Operating Distance	0 - 15m	-	-	-	√	-	-	-	-	-	√	-	-
Background Suppression Distance	250 - 200mm	-	-	-	-	√	-	-	-	-	-	√	-
Convergent	5 to 35mm	-	-	-	-	-	√	-	-	-	-	-	√
Power Supply	10 - 30V DC ¹	√	√	√	√	√	√	√	√	√	√	√	√
Current Draw	Projector: 15mA, Receiver 20mA	-	-	-	√	-	-	-	-	-	√	-	-
	30mA max.	√	√	√	-	√	√	√	√	√	-	√	√
Light Emission²	Red LED 665nm	√	√	-	√	√	-	√	√	-	√	√	-
	Infrared LED 870nm	-	-	√	√	-	√	-	-	√	√	-	√
Setting	Sensitivity adjustment	√	√	√	√	√	√	√	√	√	√	√	√
Indicators	Yellow OUTPUT LED	√	√	√	√	√	√	√	√	√	√	√	√
	Green STABILITY LED	√	√	√	√	-	-	√	√	√	√	-	-
	Green POWER ON LED	√	√	√	√	-	-	√	√	√	√	-	-
Output Type	PNP or NPN (refer to part number table)	√	√	√	√	√	√	√	√	√	√	√	√
Operating Mode	Dark On or Light On (refer to part number table)	√	√	√	√	√	√	√	√	√	√	√	√
Saturation Voltage	≤ 2V	√	√	√	√	√	√	√	√	√	√	√	√
Response Time	1ms	√	√	√	√	√	√	√	√	√	√	√	√
Switching Frequency	500Hz	√	√	√	√	√	√	√	√	√	√	√	√
Output Current	≤ 100mA	√	√	√	√	√	√	√	√	√	√	√	√
Connection	2m cable, Ø 3.5mm	√	√	√	√	√	√	-	-	-	-	-	-
	4-pole M8 connector	-	-	-	-	-	-	√	√	√	√	√	√
Mechanical Protection	IP67	√	√	√	√	√	√	√	√	√	√	√	√
Protection Devices	A, B ³	√	√	√	√	√	√	√	√	√	√	√	√
Housing Material	PC / PBT	√	√	√	√	√	√	√	√	√	√	√	√
Lens Material	PMMA	√	-	-	-	-	-	√	-	-	-	-	-
	PC	-	√	√	√	√	√	-	√	√	√	√	√
Weight	10g	-	-	-	-	-	-	√	√	√	√	-	√
	20g	-	-	-	-	-	-	-	-	-	-	√	-
	30g	√	√	√	√	-	-	-	-	-	-	-	-
	50g	-	-	-	-	-	√	-	-	-	-	-	-
	55g	-	-	-	-	√	-	-	-	-	-	-	-
Operating Temperature	-25 to +55°C	√	√	√	√	√	√	√	√	√	√	√	√
Storage Temperature	-40 to +70°C	√	√	√	√	√	√	√	√	√	√	√	√
Standard Reference	EN60947-5-2	√	√	√	√	√	√	√	√	√	√	√	√



1. Limit values
 2. Average life of 100,000 hrs with T_A = +25°C
 3. A - reverse polarity protection
 B - overload and short-circuit (SA1E- P, SA1E- N, SA1E-D, SA1E-T)

Part Numbers

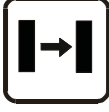
Function	Operation Mode	Output	Cable Type	Cable Length	Weight	Dimensions	Part Number
 Convergent	Light On	NPN	Cable	2m	50g	31.5 x 10.8 x 19.5mm	SA1E-GN1-2M
	Light On	NPN	M8 Connector	–	10g	42.3 x 10.8 x 19.5mm	SA1E-GN1C
	Dark On	NPN	Cable	2m	50g	31.5 x 10.8 x 19.5mm	SA1E-GN2-2M
	Dark On	NPN	M8 Connector	–	10g	42.3 x 10.8 x 19.5mm	SA1E-GN2C
	Light On	PNP	Cable	2m	50g	31.5 x 10.8 x 19.5mm	SA1E-GP1-2M
	Light On	PNP	M8 Connector	–	10g	42.3 x 10.8 x 19.5mm	SA1E-GP1C
	Dark On	PNP	Cable	2m	50g	31.5 x 10.8 x 19.5mm	SA1E-GP2-2M
	Dark On	PNP	M8 Connector	–	10g	42.3 x 10.8 x 19.5mm	SA1E-GP2C
 Background Suppression (Fixed Field)	Light On	NPN	Cable	2m	50g	31.5 x 10.8 x 19.5mm	SA1E-BN1-2M
	Light On	NPN	M8 Connector	–	10g	42.3 x 10.8 x 19.5mm	SA1E-BN1C
	Dark On	NPN	Cable	2m	50g	31.5 x 10.8 x 19.5mm	SA1E-BN2-2M
	Dark On	NPN	M8 Connector	–	10g	42.3 x 10.8 x 19.5mm	SA1E-BN2C
	Light On	PNP	Cable	2m	50g	31.5 x 10.8 x 19.5mm	SA1E-BP1-2M
	Light On	PNP	M8 Connector	–	10g	42.3 x 10.8 x 19.5mm	SA1E-BP1C
	Dark On	PNP	Cable	2m	50g	31.5 x 10.8 x 19.5mm	SA1E-BP2-2M
	Dark On	PNP	M8 Connector	–	10g	42.3 x 10.8 x 19.5mm	SA1E-BP2C
 Diffuse Reflective	Light On	NPN	Cable	2m	50g	31.5 x 10.8 x 19.5mm	SA1E-DN1-2M
	Light On	NPN	M8 Connector	–	10g	42.3 x 10.8 x 19.5mm	SA1E-DN1C
	Dark On	NPN	Cable	2m	50g	31.5 x 10.8 x 19.5mm	SA1E-DN2-2M
	Dark On	NPN	M8 Connector	–	10g	42.3 x 10.8 x 19.5mm	SA1E-DN2C
	Light On	PNP	Cable	2m	50g	31.5 x 10.8 x 19.5mm	SA1E-DP1-2M
	Light On	PNP	M8 Connector	–	10g	42.3 x 10.8 x 19.5mm	SA1E-DP1C
	Dark On	PNP	Cable	2m	50g	31.5 x 10.8 x 19.5mm	SA1E-DP2-2M
	Dark On	PNP	M8 Connector	–	10g	42.3 x 10.8 x 19.5mm	SA1E-DP2C
 Small Beam Reflective	Light On	NPN	Cable	2m	50g	31.5 x 10.8 x 19.5mm	SA1E-NN1-2M
	Light On	NPN	M8 Connector	–	10g	42.3 x 10.8 x 19.5mm	SA1E-NN1C
	Dark On	NPN	Cable	2m	50g	31.5 x 10.8 x 19.5mm	SA1E-NN2-2M
	Dark On	NPN	M8 Connector	–	10g	42.3 x 10.8 x 19.5mm	SA1E-NN2C
	Light On	PNP	Cable	2m	50g	31.5 x 10.8 x 19.5mm	SA1E-NP1-2M
	Light On	PNP	M8 Connector	–	10g	42.3 x 10.8 x 19.5mm	SA1E-NP1C
	Dark On	PNP	Cable	2m	50g	31.5 x 10.8 x 19.5mm	SA1E-NP2-2M
	Dark On	PNP	M8 Connector	–	10g	42.3 x 10.8 x 19.5mm	SA1E-NP2C
 Polarized Retro-reflective	Light On	NPN	Cable	2m	50g	31.5 x 10.8 x 19.5mm	SA1E-PN1-2M
	Light On	NPN	M8 Connector	–	10g	42.3 x 10.8 x 19.5mm	SA1E-PN1C
	Dark On	NPN	Cable	2m	50g	31.5 x 10.8 x 19.5mm	SA1E-PN2-2M
	Dark On	NPN	M8 Connector	–	10g	42.3 x 10.8 x 19.5mm	SA1E-PN2C
	Light On	PNP	Cable	2m	50g	31.5 x 10.8 x 19.5mm	SA1E-PP1-2M
	Light On	PNP	M8 Connector	–	10g	42.3 x 10.8 x 19.5mm	SA1E-PP1C
	Dark On	PNP	Cable	2m	50g	31.5 x 10.8 x 19.5mm	SA1E-PP2-2M
	Dark On	PNP	M8 Connector	–	10g	42.3 x 10.8 x 19.5mm	SA1E-PP2C
 Through-beam	Light On	NPN	Cable	2m	50g	31.5 x 10.8 x 19.5mm	SA1E-TN1-2M
	Light On	NPN	M8 Connector	–	20g	42.3 x 10.8 x 19.5mm	SA1E-TN1C
	Dark On	NPN	Cable	2m	50g	31.5 x 10.8 x 19.5mm	SA1E-TN2-2M
	Dark On	NPN	M8 Connector	–	20g	42.3 x 10.8 x 19.5mm	SA1E-TN2C
	Light On	PNP	Cable	2m	50g	31.5 x 10.8 x 19.5mm	SA1E-TP1-2M
	Light On	PNP	M8 Connector	–	20g	42.3 x 10.8 x 19.5mm	SA1E-TP1C
	Dark On	PNP	Cable	2m	50g	31.5 x 10.8 x 19.5mm	SA1E-TP2-2M
	Dark On	PNP	M8 Connector	–	20g	42.3 x 10.8 x 19.5mm	SA1E-TP2C

Fiber Optic Analog: SA1C-FK

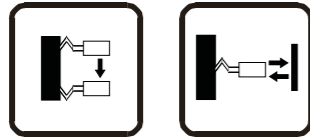

- High-speed, miniature photoelectric sensors with analog (4 - 20mA) and digital output
- Senses gradual color changes
- Available in both red and green LEDs
- Through-beam and reflected-light sensing available
- Ideal for either color mark applications or simple presence and absence applications requiring analog output
- Compact size allows for DIN rail mounting
- Fiber optic units available to address specific application needs
- Simple to install
- IP66 protection rating

Built on the foundation of SA1C-F, SA1C-FK is ideal for either color mark applications or simple presence and absence applications requiring analog output.

Featuring analog and digital output, this sensor comes in through-beam or reflected-light sensing styles.

Dimensions (mm)

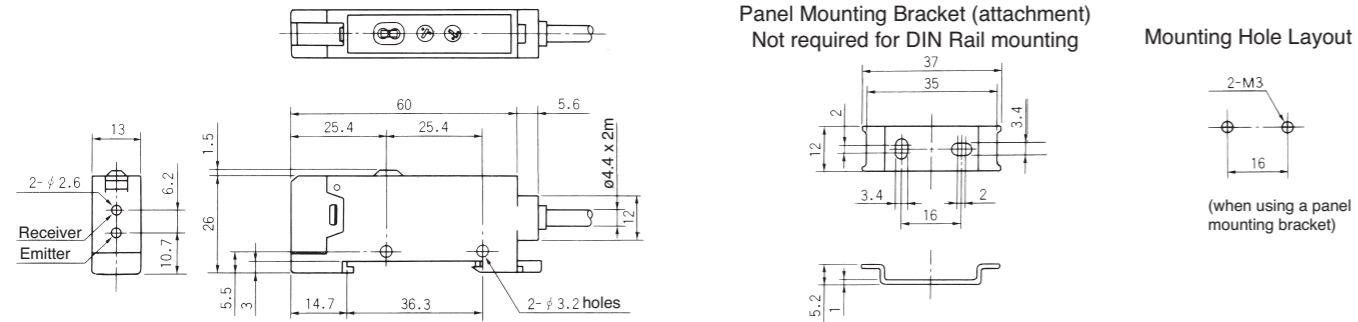

Specifications

		SA1C-FK3	SA1C-FK3G
Light Source Element	Red LED	√	—
	Green LED	—	√
Sensing Distance	Depends on the fiber unit (see page 173)	√	√
Power Voltage	12 to 24V DC (Operating voltage: 10 to 30V DC) ripple 10% maximum	√	√
Current Draw	80mA maximum	√	√
Analog Current Output	4 to 20mA, 5V DC maximum ¹	√	√
Digital Output	NPN open collector 30V DC, 100mA maximum, 1.5V maximum with short circuit protection	√	√
Operation Mode	Dark ON (connect MODE line to GND line)	√	√
	Light ON (connect MODE line to power line)	√	√
Response	0.5ms maximum ²	√	√
Indicator	Operation LED: Red, Stable LED: Green	√	√
Detectable Object	Translucent object, opaque object	√	√
Hysteresis	20% maximum (using reflex fiber unit)	√	√
Sensitivity	4-turn adjustment	√	√
Operation Point Control	1 turn	√	√
Receiver Element	Photo diode	√	√
Operating Temperature	−25 to +55°C (performance will be adversely affected if the sensor becomes coated with ice)	√	√
Storage Temperature	−30 to +70°C (performance will be adversely affected if the sensor becomes coated with ice)	√	√
Operating Humidity	35 to 85% RH (avoid condensation)	√	√
Extraneous Light Immunity	Sunlight: 10,000 lux maximum; Incandescent light: 3,000 lux (at the receiver)	√	√
Noise Resistance	Normal mode: 500V (50ns to 1μs, 100Hz: Using a noise simulator)	√	√
	Common mode: 300V (50ns to 1μs, 100Hz: Using a noise simulator)	√	√
Insulation Resistance	Between live and dead parts: 20MΩ minimum, with 500V DC megger	√	√
Dielectric Strength	Between live and dead parts: 1,000V, 1 minute	√	√
Vibration Resistance	Damage limits: 10 to 55Hz; Single amplitude: 0.75mm 20 cycles in each of 3 axes	√	√
Shock Resistance	Damage limits: 500 m/sec ² 10 cycles in each of 3 axes	√	√
Degree of Protection	IP66—IEC Pub 529	√	√
Cable	Cable type: Ø4.4mm 5-core vinyl cabtyre cable 0.2mm ² , 6'–6-3/4" (2m) long	√	√
Material	Housing: PBT	√	√
Accessories	Mounting bracket, adjusting screwdriver, load resistor (249Ω) for converting analog amperage to voltage (1 to 5V)	√	√
Interference Prevention	Up to 2 units can be installed in close proximity. For analog output, interference prevention is not possible.	√	√
Weight	Approximately 75g	√	√



- Analog current output specification is based on the power voltage range from 12 to 24V DC (±10%). Use the attached resistor (249Ω, 1/4W) as a load resistance for converting analog output to voltage.
- Response time for analog current output is between 10% and 90% of the rise or fall of the voltage signal when using a 249Ω resistor.

Part Numbers

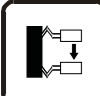
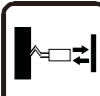
Function	Light Source Element	Output	Part Number
	Red LED	Analog output + NPN output	SA1C-FK3
	Green LED		SA1C-FK3G

For information on accessories, see page 171.

 Function is determined by the fiber optic unit used.

Applications

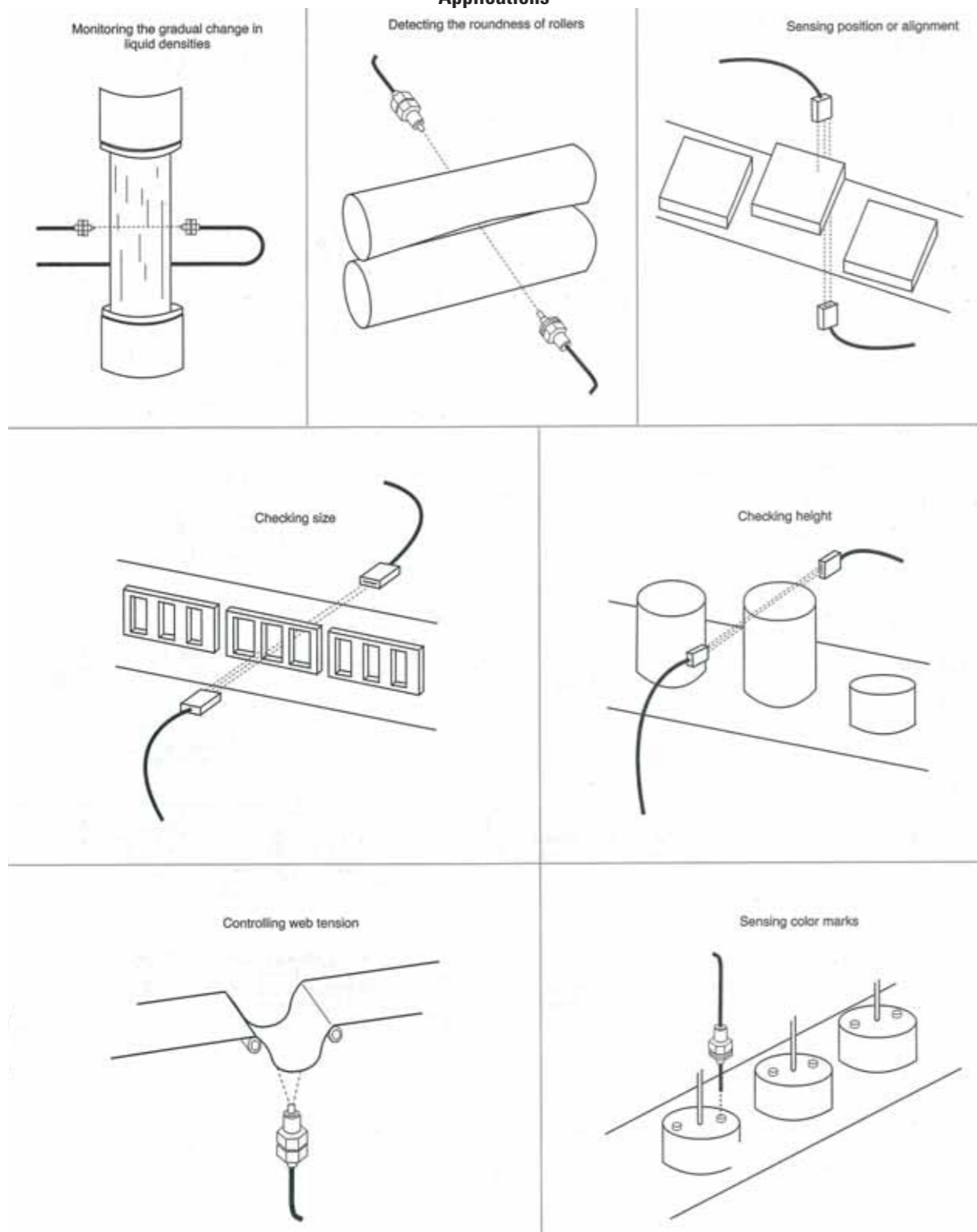

High-speed Fiber Optic: SA1C-F



- Ideal for remote sensing applications
- Featuring quick-connect cable and easy-insert fiber optic units for simple installation
- Through-beam and reflected-light sensing available
- Sensing range up to 7.09" (180mm) for through-beam sensors
- Dual outputs: Select NPN and PNP transistor outputs or NPN transistor output combined with a self-diagnostic output
- Outputs selectable for light on or dark on
- High-speed, 50 μ s response time
- Featuring variable off-delay (0 to 100msec) and fine-tune sensitivity adjustment
- Stable LED makes alignment easy
- Red or green LEDs available for detecting color marks
- Mount on a 35mm DIN rail

The perfect fiber optic sensor for applications where you have difficulty mounting regular or miniature sensors or where accessibility is a problem.

Available in through-beam and retro-reflective models, the built-in variable off-delay (0 - 10ms) can help you bring your complete system in tune.

The 50 μ s response time ensures detection of fast moving targets in a high-speed manufacturing environment where speed counts.

Dimensions (mm)

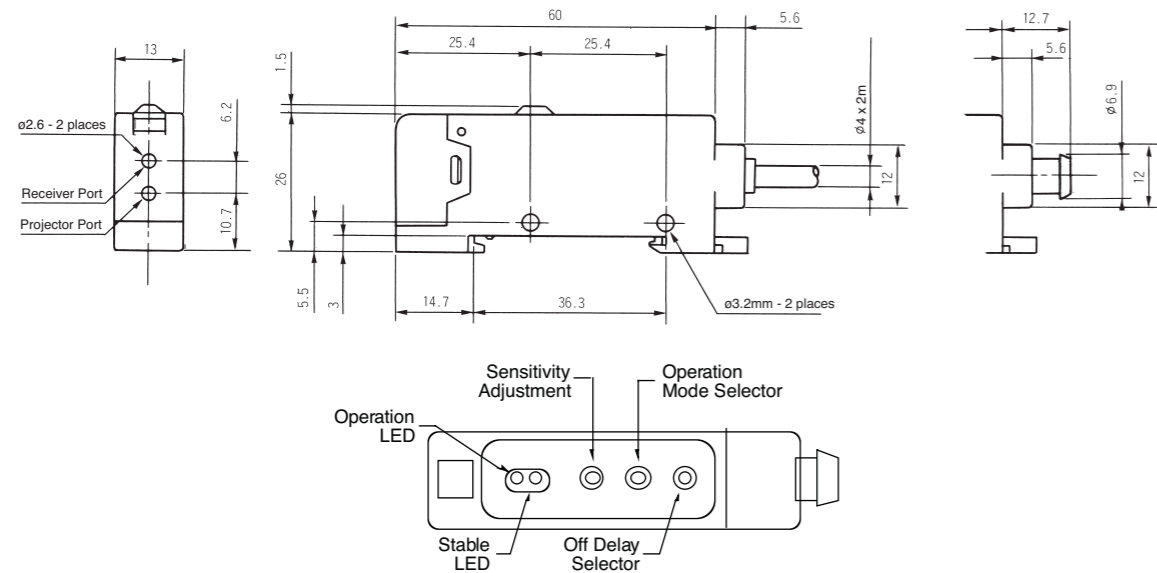

Specifications

		SA1C-FN, -FD (Standard Speed)	SA1C-F1N, -F1D (High-speed)	
General Specifications	Power Voltage	12V to 24V DC	√	
	Operating Voltage	10V to 30V DC, ripple 10% (maximum)	√	
	Current Draw	30mA (maximum)	√	—
		40mA (maximum)	—	√
	Operating Temperature	Amplifier only: -25° to +55°C Fiber optic cords (except heat-resistant types): -40° to +70°C Heat-resistant fiber optic cords: -40°C to +350°C (avoid ice coating)	√	√
	Operating Humidity	35 to 85% RH (avoid condensation)	√	√
	Extraneous Light Immunity	Sunlight: 10,000 lux (maximum); Incandescent light: 3,000 lux (maximum) on receiver surface— defined as incident or unwanted light received by a sensor, unrelated to the presence or absence of the intended object	√	√
	Material	Amplifier only: PBT resin (housing) with polycarbonate lens Fiber optic cords (except heat-resistant types): Nickel-plated brass (sensing head), polyethylene-covered PMMA (cord), and SUS304 stainless (sleeve) Heat-resistant fiber optic cords: SUS 304 stainless (sensing head) and SUS spiral tube around glass fiber cord	√	√
	Degree of Protection	IP66 — IEC Pub 529, sensors rated IP66 are dust-tight, water-resistant, and perform best when not subjected to heavy particle or water blasts	√	√
	Cable	Cable type: 0.2mm ² ; Vinyl cabtyre cable #24 AWG, 6'-6-3/4' (2m) long Connector type: Ø 0.31" (8mm) 3- or 4-pin connector (cable ordered separately for quick connect sensors)	√	√
	Light Source	Red or green LED (pulse-modulated)	√	√
	Output	NPN transistor: 30V DC (1.2V residual), 100mA (maximum)	√	√
		PNP transistor: 30V DC (2.0V residual), 200mA (maximum) Self-diagnostic: 30V DC (1.2V residual), 50mA (maximum)		
	Response	0.5ms (maximum)	√	—
50µs (maximum)		—	√	
Off Delay	0 to 100 ms (adjustable)	√	√	
Sensitivity	4-turn adjustment	√	√	
Minimum Bending Radius	Fiber optic cord (except SA9F-TT, -DT, -TL, and -DL): 1"R (25mm); Sleeve: 0.39"R (10mm) SA9F-TT and -DT: 0.59"R (15mm); Sleeve: 0.39"R (10mm) SA9F-TL and DL: 0.59"R (15mm); Sleeve: Unbendable	√	√	



			SA1C-FN, -FD (Standard Speed)	SA1C-F1N, -F1D (High-speed)	
Function Specifications	Operation Mode		Light on or dark on (selectable by switch on amplifier)	√	√
	Indicator		Operation indicator: Red LED (out)	√	√
			Stable level indicator: Green LED (stable)	√	√
	Noise Resistance	Normal Mode	500V	√	–
			300V	–	√
		Common Mode	300V	√	–
	150V		–	√	
	Pulse Width		50ns –1μs, 100Hz (using a noise simulator)	√	√
	Storage Temperature		–30 to +70°C (avoid freezing)	√	√
	Insulation Resistance		20M minimum with 500V DC megger (between live & dead parts)	√	√
	Dielectric Strength		1000V, 1 minute (between live & dead parts)	√	√
Vibration Resistance		Damage limits: 10 – 55Hz Amplitude: 1.5mm p-p, 20 cycles in each of 3 axes crossed (one cycle = 5 minutes)	√	√	
Shock Resistance		Damage limits: 500m/s ² (approximately 49G), 10 shocks in each of 3 axes	√	√	
Weight		Cable type: Approximately 75g Quick-connect type: Approximately 30g	√	√	

Detecting Color Marks

Color of Mark	Background Color										
	White	Yellow	Chartreuse	Orange	Red	Magenta	Turquoise	Blue	Violet	Green	Black
White	–	❖	◆	❖	❖	◆	◆	◆	◆	◆	◆
Yellow	❖	–	◆	❖	❖	❖	◆	◆	◆	◆	◆
Chartreuse	◆	◆	–	□	□	❖	□	◆	❖	◆	◆
Orange	❖	❖	□	–	–	❖	□	◆	◆	◆	◆
Red	❖	❖	□	–	–	□	□	◆	◆	◆	◆
Magenta	◆	❖	❖	❖	□	–	□	□	–	□	◆
Turquoise	◆	◆	□	□	□	□	–	□	◆	❖	◆
Blue	◆	◆	◆	◆	◆	□	□	–	□	□	□
Violet	◆	◆	❖	◆	◆	–	◆	□	–	□	□
Green	◆	◆	◆	◆	◆	□	❖	□	□	–	□
Black	◆	◆	◆	◆	◆	◆	◆	□	□	□	–

□ = Use Red LED
 ❖ = Use Green LED
 ◆ = Use Red or Green LED
 – = Not Detectable

Part Numbers

Function	Amplifier	Output	Light Source	Response	Through-Beam Units		Diffuse-Reflected Units	
					Part Number	Range	Part Number	Range
	SA1C-FN3E (Cable) SA1C-FN3EC (Quick-Connect)	30V DC NPN transistor: 100mA (maximum) Self-diagnostic: 50mA (maximum)	Red LED	Standard speed: 0.5 ms	SA9F-TS: ø0.16" (M4) Straight	180mm (7.09")	SA9F-DS: ø0.24" (M6) Straight	60mm (2.36")
	SA1C-FD3F (Cable) SA1C-FD3FC (Quick-Connect)	30V DC NPN transistor: 100mA (maximum) PNP transistor: 200mA (maximum)			SA9F-TC: ø0.16" (M4) Coiled	150mm (5.91")	SA9F-DC: ø0.24" (M6) Coiled	25mm (0.98")
	SA1C-FN3EG (Cable) SA1C-FN3EGC (Quick-Connect)	30V DC NPN transistor: 100mA (maximum) Self-diagnostic: 50mA (maximum)	Green LED	Standard speed: 0.5 ms	SA9F-TT: ø0.12" (M3) Straight	50mm (1.97")	SA9F-DD: ø0.24" (M6) Coaxial	60mm (2.36")
	SA1C-FD3FG (Cable) SA1C-FD3FGC (Quick-Connect)	30V DC NPN transistor: 100mA (maximum) PNP transistor: 200mA (maximum)			SA9F-TM: ø0.16" (M4) Multicore	150mm (5.91")	SA9F-DT: ø0.12" (M3) Straight	20mm (0.79")
	SA1C-F1N3E (Cable) SA1C-F1N3EC (Quick-Connect)	30V DC NPN transistor: 100mA (maximum) Self-diagnostic: 50mA (maximum)	Red LED	High- speed: 50 µs	SA9F-TL: Heat-resistant glass fiber Side view	100mm (3.94")	SA9F-DM: ø0.01" (0.26mm) Multicore	60mm (2.36")
	SA1C-F1D3F (Cable) SA1C-F1D3FC (Quick-Connect)	30V DC NPN transistor: 100mA (maximum) PNP transistor: 200mA (maximum)			SA9F-DH: Heat-resistant glass fiber Side view	40mm (1.57")	SA9F-DL: Heat-resistant glass fiber Side view	10mm (0.39")
	SA1C-FN3EG (Cable) SA1C-FN3EGC (Quick-Connect)	30V DC NPN transistor: 100mA (maximum) Self-diagnostic: 50mA (maximum)	Green LED	Standard speed: 0.5 ms	SA9F-TS: ø0.16" (M4) Straight	16mm (0.63")	SA9F-DS: ø0.24" (M6) Straight	7mm (0.28")
	SA1C-FD3FG (Cable) SA1C-FD3FGC (Quick-Connect)	30V DC NPN transistor: 100mA (maximum) PNP transistor: 200mA (maximum)			SA9F-TC: ø0.16" (M4) Coiled	14mm (0.55")	SA9F-DC: Incompatible with green LED	N/A
	SA1C-F1N3E (Cable) SA1C-F1N3EC (Quick-Connect)	30V DC NPN transistor: 100mA (maximum) Self-diagnostic: 50mA (maximum)	Red LED	High- speed: 50 µs	SA9F-TT: ø0.12" (M3) Straight	5mm (0.20")	SA9F-DD: ø0.24" (M6) Coaxial	7mm (0.28")
	SA1C-F1D3F (Cable) SA1C-F1D3FC (Quick-Connect)	30V DC NPN transistor: 100mA (maximum) PNP transistor: 200mA (maximum)			SA9F-TM: ø0.16" (M4) Multicore	14mm (0.55")	SA9F-DT: Incompatible with green LED	N/A
	SA1C-FN3EG (Cable) SA1C-FN3EGC (Quick-Connect)	30V DC NPN transistor: 100mA (maximum) Self-diagnostic: 50mA (maximum)	Green LED	Standard speed: 0.5 ms	SA9F-TL: Heat-resistant glass fiber Incompatible with green LED	N/A	SA9F-DM: ø0.01" (0.26mm) Multicore	4mm (0.16")
	SA1C-FD3FG (Cable) SA1C-FD3FGC (Quick-Connect)	30V DC NPN transistor: 100mA (maximum) PNP transistor: 200mA (maximum)			SA9F-DH: Incompatible with green LED	N/A	SA9F-DL: Incompatible with green LED	N/A
	SA1C-F1N3E (Cable) SA1C-F1N3EC (Quick-Connect)	30V DC NPN transistor: 100mA (maximum) Self-diagnostic: 50mA (maximum)	Red LED	High- speed: 50 µs	SA9F-TS: ø0.16" (M4) Straight	50mm (1.97")	SA9F-DS: ø0.24" (M6) Straight	20mm (0.79")
	SA1C-F1D3F (Cable) SA1C-F1D3FC (Quick-Connect)	30V DC NPN transistor: 100mA (maximum) PNP transistor: 200mA (maximum)			SA9F-TC: ø0.16" (M4) Coiled	40mm (1.57")	SA9F-DC: ø0.24" (M6) Coiled	7mm (0.28")
	SA1C-FN3EG (Cable) SA1C-FN3EGC (Quick-Connect)	30V DC NPN transistor: 100mA (maximum) Self-diagnostic: 50mA (maximum)	Green LED	Standard speed: 0.5 ms	SA9F-TT: ø0.12" (M3) Straight	15mm (0.59")	SA9F-DD: ø0.24" (M6) Coaxial	20mm (0.79")
	SA1C-FD3FG (Cable) SA1C-FD3FGC (Quick-Connect)	30V DC NPN transistor: 100mA (maximum) PNP transistor: 200mA (maximum)			SA9F-TM: ø0.16" (M4) Multicore	40mm (1.57")	SA9F-DT: ø0.12" (M3) Straight	6mm (0.24")
	SA1C-F1N3E (Cable) SA1C-F1N3EC (Quick-Connect)	30V DC NPN transistor: 100mA (maximum) Self-diagnostic: 50mA (maximum)	Red LED	High- speed: 50 µs	SA9F-TL: Heat-resistant glass fiber Side view	40mm (1.57")	SA9F-DM: ø0.01" (0.26mm) Multicore	18mm (0.71")
	SA1C-F1D3F (Cable) SA1C-F1D3FC (Quick-Connect)	30V DC NPN transistor: 100mA (maximum) PNP transistor: 200mA (maximum)			SA9F-DH: Heat-resistant glass fiber Side view	13mm (0.51")	SA9F-DL: Heat-resistant glass fiber Side view	3mm (0.12")



Function is determined by the fiber optic unit used.

For information on accessories, see page 171.









Universal Sensors

Accessories

Reflectors

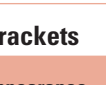
Appearance	Item	Use with	Part Number
	200 x 300mm self-adhesive reflective tape		S94000600 (model RT3870)
	200 x 300mm self-adhesive reflective tape		S94000900 (model RT3970)
	60 x 40mm self-adhesive reflective tape		S94000604 (model RT3970)
	Ø 23mm prismatic reflector with Ø 31mm support		S940700023 (model R1)
	Ø 48mm prismatic reflector with Ø 63mm support		S940700048 (model R2)
	18 x 54mm prismatic reflector with 22 x 82mm support		S940700972 (model R3)
	47x 47mm prismatic reflector with 51.5 x 61mm support	S51, S60, S62	95A151010 (model R4)
	Ø 75mm prismatic reflector with Ø 82mm support		S940700075 (model R5)
	36 x 55mm prismatic reflector with 40.5 x 60mm support		95A151020 (model R6)
	38 x 40mm microprism reflector with 51 x 60.7mm support		95A151050 (model R7)
	9.7 x 19mm microprism reflector with 13.8 x 23mm support		95A151060 (model R8)
	Ø 23mm prismatic reflector with Ø 25mm self-adhesive support		95A151080 (model R9)
	36 x 176mm prismatic reflector with 41 x 181mm support		S19120000 (model R10)
	146 x 15mm prismatic reflector with 150 x 18mm support		95A155050 (model R11)

Reflectors

Appearance	Item	Use with	Part Number
	Ø 48mm prismatic reflector with Ø 63mm support	S51, S60, S62	95A151090 (model R20)
	Ø 48mm prismatic reflector with CH.52mm hexagon support		S940710048 (model S12)
	Standard reflector		IAC-R5
	Small reflector	SA1E	IAC-R6
	Large reflector		IAC-R8
	Narrow (rear/side mounting)		IAC-R7M
	Narrow (rear mounting)		IAC-R7B
	Tape (35 x 40mm)		IAC-RS1
	Tape (70 x 80mm)		IAC-RS2

Brackets

Appearance	Item	Use with	Part Number
	M18/14 mounting bracket		95ACC5230 (model ST-5010)
	M18 mounting bracket		95ACC5240 (model ST-5011)
	M18 mounting bracket		95ACC5250 (model ST-5012)
	M18 mounting bracket	S51	95ACC5270 (model ST-5017)
	M18/14 adjustable mounting support (sensor not included)		95ACC5300 (model S50-EASY-IN)
	M18 jointed support		95ACC5220 (model JOINT-18)
	support with micrometric regulation for M18 tubular		95ACC1380 (model MICRO-18)

Brackets

Appearance	Item	Use with	Part Number
	Front protection	S51	G5000001 (model MEK-PROOF)
	1pc adjustable support for M18 tubular		895000006 (model SWING-18)
	2 pcs fixed support for M18 tubular		95ACC1370 (model SP-40)
	Protection bracket with jointed support	S60	95ACC5350 (model JOINT-60)
	S60 mounting bracket		95ACC1320 (model ST-504)
	Protection bracket		95ACC5310 (model ST-5018)
	Protection bracket		95ACC5320 (model ST-5019)
	Mounting bracket		95ACC5330 (model ST-5020)
	Mounting bracket	S60, S62, S65	95ACC5340 (model ST-5021)
	Protection bracket	S62	95ACC2410 (model ST-5053)
	Protection bracket		95ACC2420 (model ST-5054)
	Vertical mounting bracket	SA1E	SA9Z-K01
	Horizontal mounting bracket		SA9Z-K02
	Cover mounting bracket		SA9Z-K03
	Reflector mounting bracket	SA1E	IAC-L2
	Reflector mounting bracket		IAC-L3
	Reflector mounting bracket		IAC-L5
	Reflector mounting bracket		

Slits

Appearance	Item	Slit Size	Use with	Part Number	Min. Order Qty
	Vertical slit	0.5mm x 18mm	SA1E	SA9Z-S06	2
		1.0mm x 18mm		SA9Z-S07	
		2.0mm x 18mm		SA9Z-S08	
	Horizontal slit	0.5mm x 6.5mm		SA9Z-S09	
		1.0mm x 6.5mm		SA9Z-S10	
		2.0mm x 6.5mm		SA9Z-S11	
	Round slit	ø0.5mm		SA9Z-S12	
		ø1.0mm		SA9Z-S13	
		ø2.0mm		SA9Z-S14	

Air Blower Mounting Blocks

Appearance	Item	Use with	Part Number
	Air blower mounting block	SA1E	SA9Z-A02







Connector Cables (for connector model sensors)

Appearance	Number of Core Wires	Type & Length	Use with	Part No.
	4	Straight, 5m	S51, S60, S62	CS-A1-02-G-05
	4	Right angle, 5m		CS-A2-02-G-05
	4	Straight, 2m	SA1E	SA9Z-CM8K-4S2
		Straight, 5m		SA9Z-CM8K-4S5
		Right angle, 2m		SA9Z-CM8K-4L2
		Right angle, 5m		SA9Z-CM8K-4L5
	4	2m	SA1C-F	SA9C-CA4D2
		5m		SA9C-CA4D5
		2m		SA9C-CA4D2S
		5m		SA9C-CA4D5S

Diffuse-Reflected Light Fiber Optic Units - SA9F

Appearance	Part Number	Description	Use with	Range
	SA9F-DS31 No sleeve SA9F-DS32 3.54" (90mm) sleeve SA9F-DS33 1.77" (45mm) sleeve	Straight: Two fibers ϕ 1mm (0.04") Threaded mount: ϕ 6mm (M6) Detects: ϕ 0.03mm (0.0012") minimum object	SA1C-FK3 SA1C-FK3G SA1C-F	60mm (2.36") 7mm (0.28")
	SA9F-DC31 No sleeve SA9F-DC32 3.54" (90mm) sleeve SA9F-DC33 1.77" (45mm) sleeve (All three not compatible with green LED)	Coiled: Two fibers ϕ 1mm (0.04") Threaded mount: ϕ 6mm (M6) Detects: ϕ 0.03mm (0.0012") minimum object	SA1C-FK3 SA1C-FK3G SA1C-F	25mm (0.98") —
	SA9F-DT11 No sleeve SA9F-DT12 3.54" (90mm) sleeve SA9F-DT13 1.77" (45mm) sleeve (All three not compatible with green LED)	Straight: Two fibers ϕ 0.5mm (0.02") Threaded mount: ϕ 3mm (M3) Detects: ϕ 0.03mm (0.0012") minimum object	SA1C-FK3 SA1C-FK3G SA1C-F	20mm (0.78") —
	SA9F-DD31	Coaxial: Core ϕ 1mm (0.04") + 16 fibers: ϕ 0.26mm (0.01") Threaded mount: ϕ 6mm (M6) Detects: ϕ 0.03mm (0.0012") minimum object	SA1C-FK3 SA1C-FK3G SA1C-F	60mm (2.36") 7mm (0.28")
	SA9F-DM74 1 row = 32 fibers SA9F-DM75 2 rows = 16 each (Not compatible with green LED)	Multicore: 32 fibers ϕ 0.26mm (0.010") Detects: ϕ 0.06mm (0.0024") minimum object	SA1C-FK SA1C-FK3G SA1C-F (not compatible with SA9F-DM75, SA9F-DM76)	60mm (2.36") 4mm (0.16")
	SA9F-DH21 No sleeve SA9F-DH22 3.54" (90mm) sleeve (Both not compatible with green LED)	Heat-resistant glass: Two fibers ϕ 0.7mm (0.03") Threaded mount: ϕ 4mm (M4) Detects: ϕ 0.03mm (0.0012") minimum object	SA1C-FK3 SA1C-FK3G SA1C-F	27mm (1.06") —

Through-Beam Fiber Optic Units - SA9F

Appearance	Part Number	Description	Amplifier	Range
	<p>SA9F-TS21 No sleeve</p> <p>SA9F-TS23 1.77" (45mm) sleeve</p>	<p>Straight fiber: ø1mm (0.04")</p> <p>Threaded mount: ø4mm (M4)</p> <p>Detects: ø0.3mm (0.012") minimum object</p>	<p>SA1C-FK3 SA1C-FK3G SA1C-F</p>	<p>180mm (7.09") 16mm (0.63")</p>
	<p>SA9F-TC21 No sleeve</p>	<p>Coiled fiber: ø1mm (0.04")</p> <p>Threaded mount: ø4mm (M4)</p> <p>Detects: ø0.3mm (0.012") minimum object</p>	<p>SA1C-FK3 SA1C-FK3G SA1C-F</p>	<p>150mm (5.91") 14mm (0.55")</p>
	<p>SA9F-TT11 No sleeve</p>	<p>Straight fiber: ø0.5mm (0.02")</p> <p>Threaded mount: ø3mm (M3)</p> <p>Detects: ø0.15mm (0.006") minimum object</p>	<p>SA1C-FK3 SA1C-FK3G SA1C-F</p>	<p>50mm (1.97") 5mm (0.2")</p>
	<p>SA9F-TM21 No sleeve</p> <p>SA9F-TM22 3.54" (90mm) sleeve</p> <p>SA9F-TM23 1.77" (45mm) sleeve</p> <p>16 fibers (cluster)</p>	<p>Multicore: ø0.26mm (0.010")</p> <p>Threaded mount: ø4mm (M4)</p> <p>Detects: ø0.3mm (0.012") minimum object</p>	<p>SA1C-FK3 SA1C-FK3G SA1C-F</p>	<p>150mm (5.91") 14mm (0.55")</p>
	<p>SA9F-TM74 16 fibers in one row</p>	<p>Multicore: 16 fibers (one row) ø0.26mm (0.010")</p> <p>Detects: ø0.06mm (0.0024") minimum object</p>	<p>SA1C-FK3 SA1C-FK3G SA1C-F</p>	<p>150mm (5.91") 14mm (0.55")</p>
	<p>SA9F-TH21 No sleeve</p> <p>SA9F-TH22 3.54" (90mm) sleeve</p>	<p>Heat-resistant glass fiber: ø1mm (0.04")</p> <p>Threaded mount: ø4mm (M4)</p> <p>Detects: ø0.3mm (0.012") minimum object</p>	<p>SA1C-FK3 SA1C-FK3G SA1C-F</p>	<p>100mm (3.94") 8mm (0.31")</p>

Miscellaneous Accessories

Description	Use with		Part Number
Fiber cutter	All fiber units except heat resistant	HxLxD: 23x 45 x 8mm (0.91" x 1.77" x 0.31") Included with fiber units; order replacement only	SA9Z-F01
Set of 2 easy-insert adaptors	SA9F-TT, SA9F-TL, SA9F-DT, and SA9F-DL	ø2.2 x 24mm long (ø0.087" (OD) x 0.945") Included with applicable fiber optic units; order replacement set only	SA9Z-F02
Lens attachment for long-range detection of opaque objects, minimum size: Ø 0.14" (3.5mm)	SA1C-F through-beam fiber unit only		SA9Z-F11
	Sensing ranges: Standard speed red LED: SA9F-TS21: 1.3m (4' - 3-3/16") SA9F-TC21: 1m (3' - 3-3/8") 0.1m (3.94") SA9F-TM21: 1.05m (3' - 5-3/8")		
	Sensing ranges: Standard speed green LED: SA9F-TS21: 0.135m (5.31") SA9F-TC21: 0.1m (3.94") SA9F-TM21: 0.13m (5.12")		
Side view attachment to rotate axis by 90° for detection of opaque objects, minimum size: Ø 0.14" (3.5mm)	SA1C-F through-beam fiber unit only		SA9Z-F12
	Sensing ranges: Standard speed red LED: SA9F-TS21: 200mm (7.87") SA9F-TC21: 130mm (5.12") SA9F-TM21: 160mm (6.30")		
	Sensing ranges: High-speed red LED: SA9F-TS21: 50mm (1.97") SA9F-TC21: 35mm (1.38") SA9F-TM21: 40mm (1.57")		
Side-on attachment for narrow clearance, Range: 1.26" (32mm), for detection of transparent or opaque objects	SA1C-F diffuse-reflected light fiber unit only		SA9Z-F13
	Sensing ranges: Standard speed red LED: SA9F-TS21: 35mm (1.38") SA9F-TC21: 30mm (1.81") SA9F-TM21: 35mm (1.38")		
Attachment for high-accuracy: Range: 0.4" ± 0.04" (10mm ± 1mm), for detection of transparent or opaque objects	SA1C-F through-beam fiber unit only		SA9Z-F14
	Sensing ranges: Standard speed red LED: SA9F-TS21: 10mm ± 1mm SA9F-TC21: (0.394" ± 0.039") SA9F-TM21:		

Dimensions (mm)
Reflectors

S940700023 (model R1)

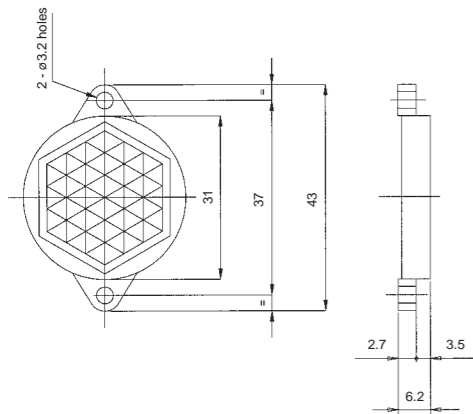

S940700048 (model R2), 95A151090 (model R20)

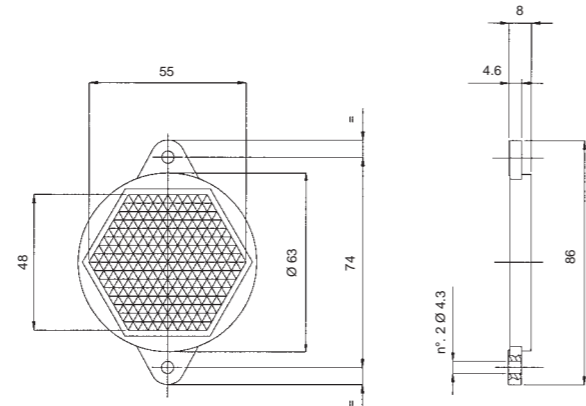

S940700972 (model R3)

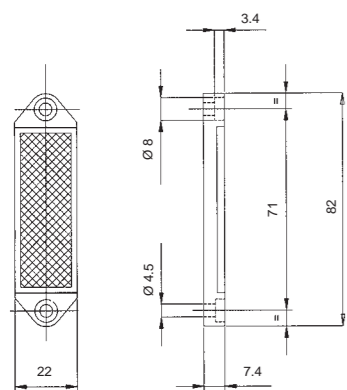

95A151010 (model R4)

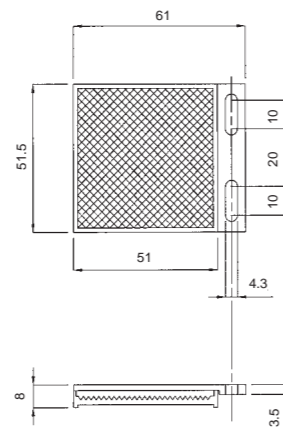

S940700075 (model R5)

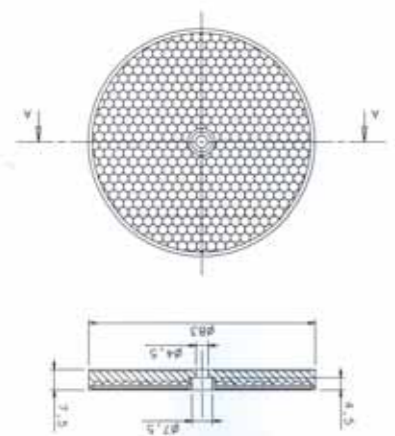

95A151020 (model R6)

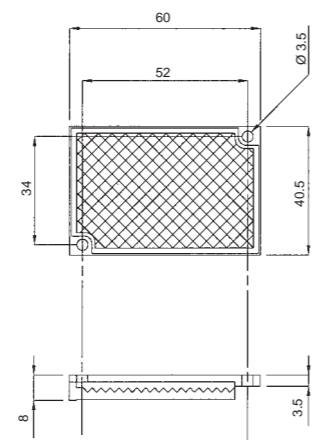

95A151050 (model R7)

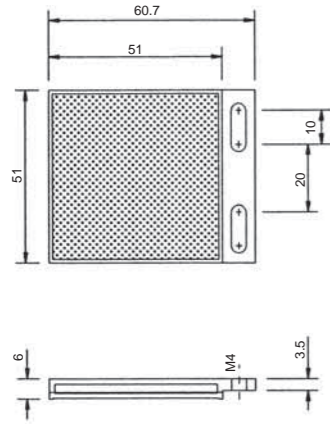

95A151060 (model R8)

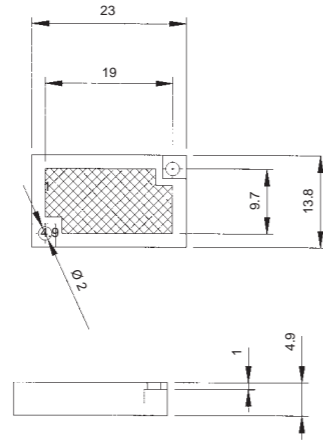

95A151080 (model R9)

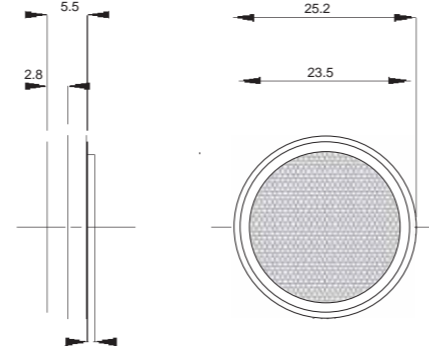

Dimensions (mm)

S19120000 (model R10)

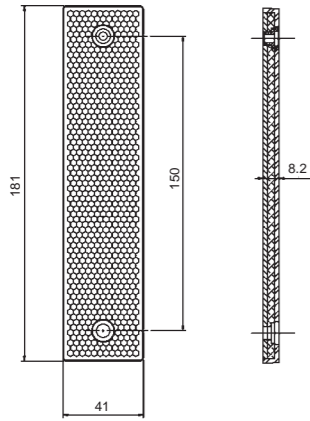

95A155050 (model R11)

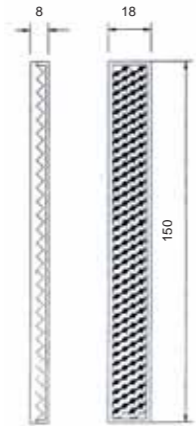

S940710048 (model S12)

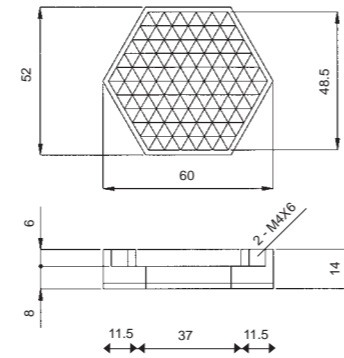

IAC-R5

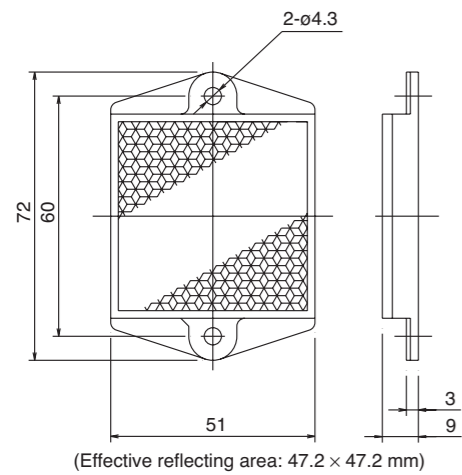

IAC-R6

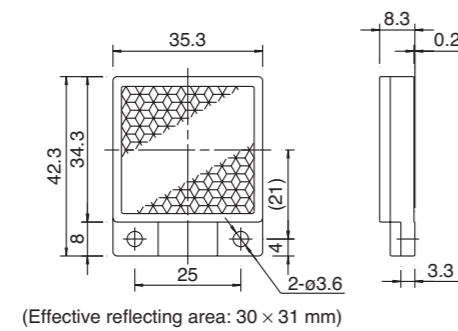

IAC-RS1

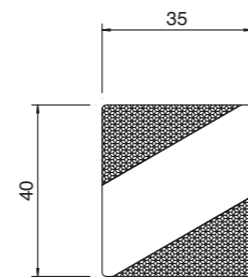

Brackets

95ACC5230 (model ST-5010)

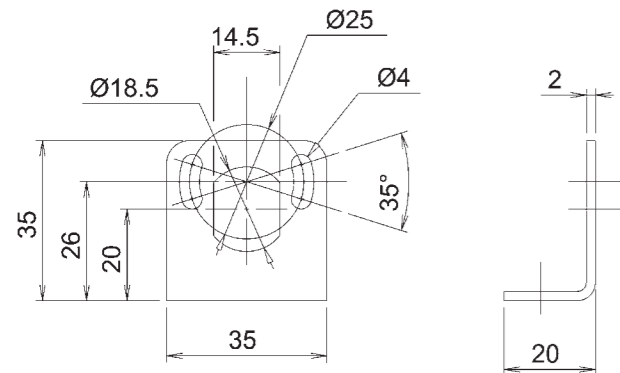

95ACC5240 (model ST-5011)

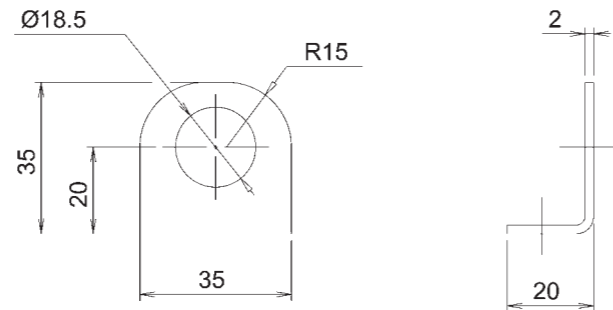

Dimensions (mm)

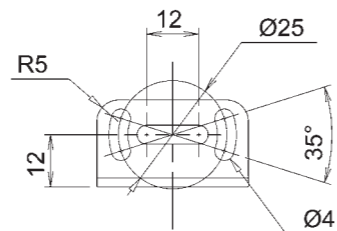
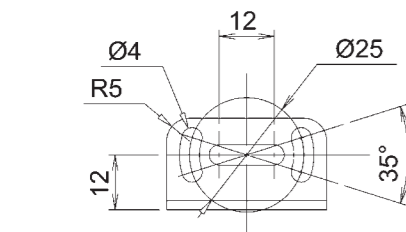

95ACC5250 (model ST-5012)

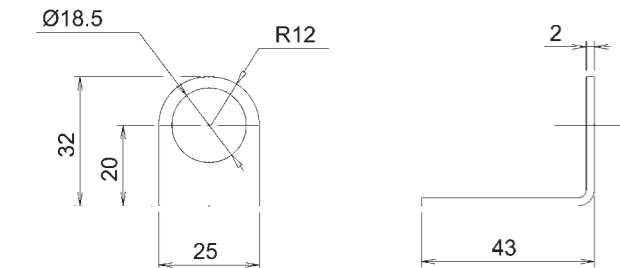

95ACC5270 (model ST-5017)

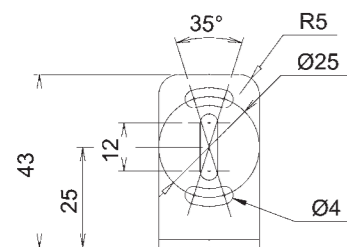
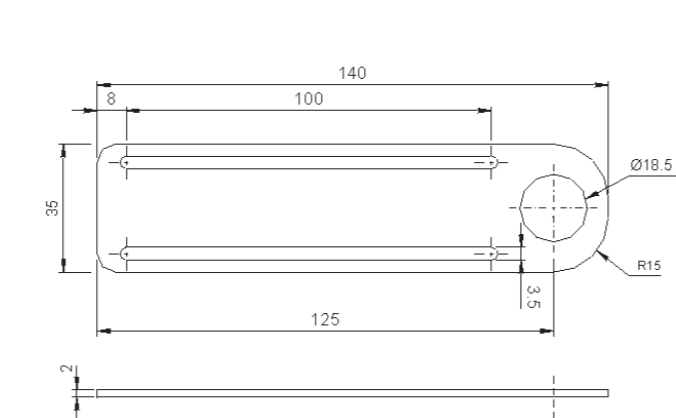

Dimensions (mm)

95ACC5300 (model S50-EASY-IN)

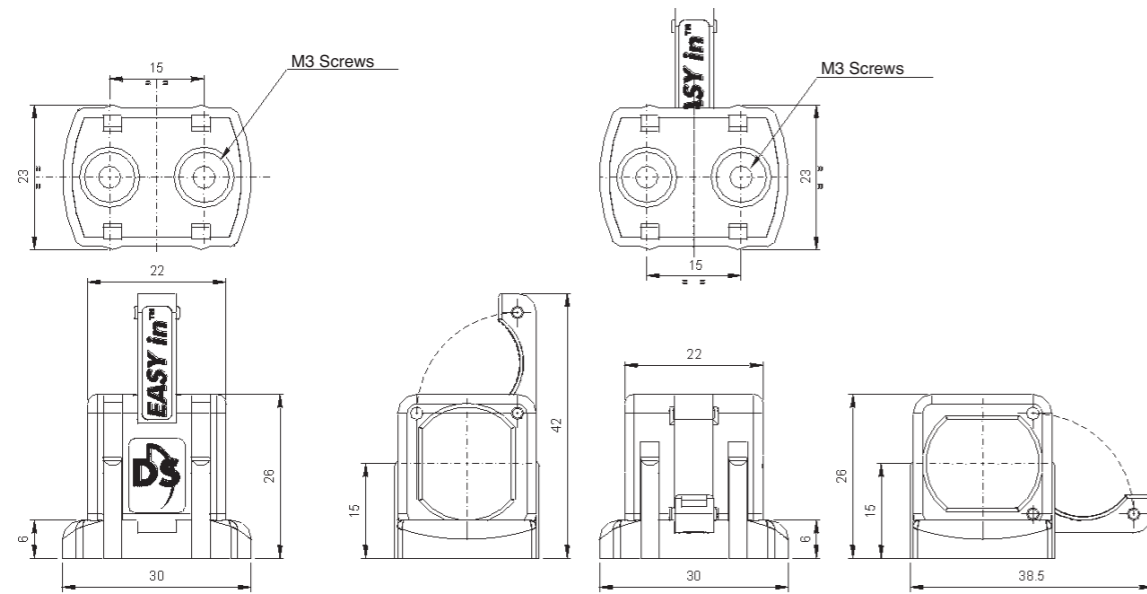

95ACC5220 (model JOINT-18)

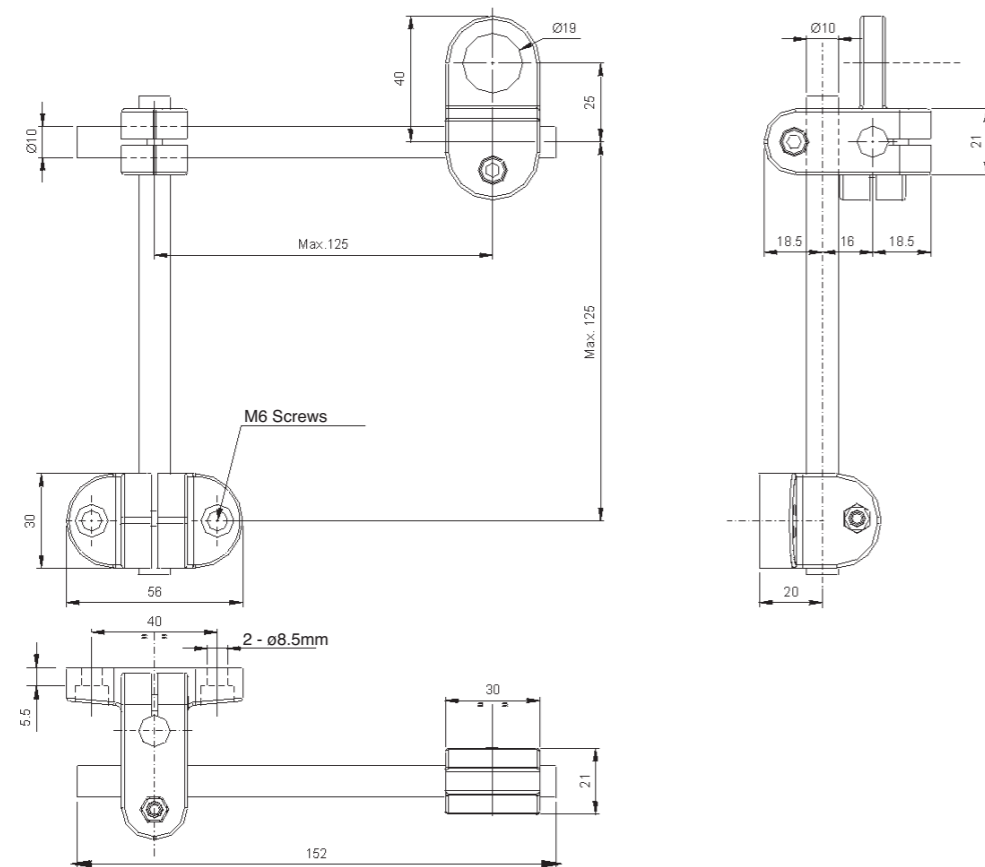

Dimensions (mm)

95ACC1380 (model MICRO-18)

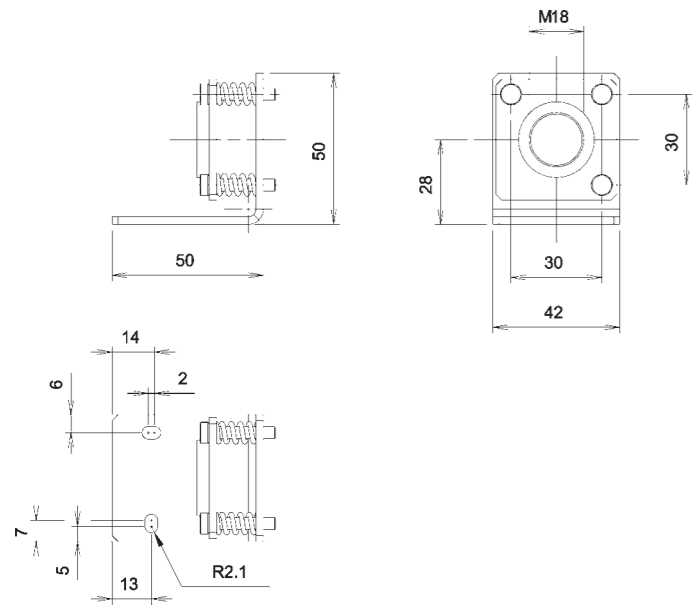

895000006 (model SWING-18)

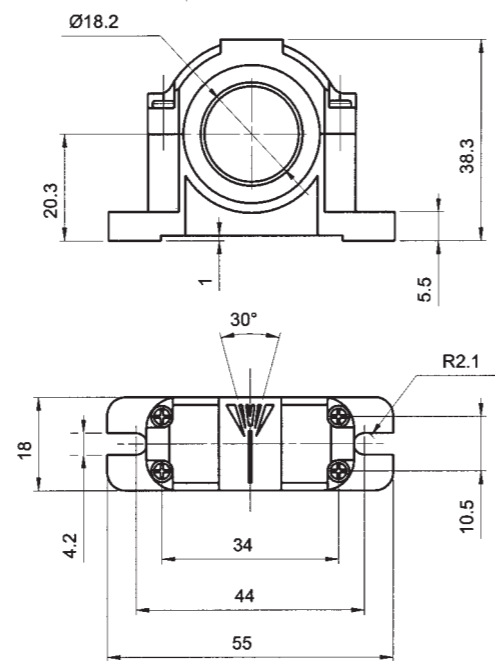

95ACC1370 (model SP-40)

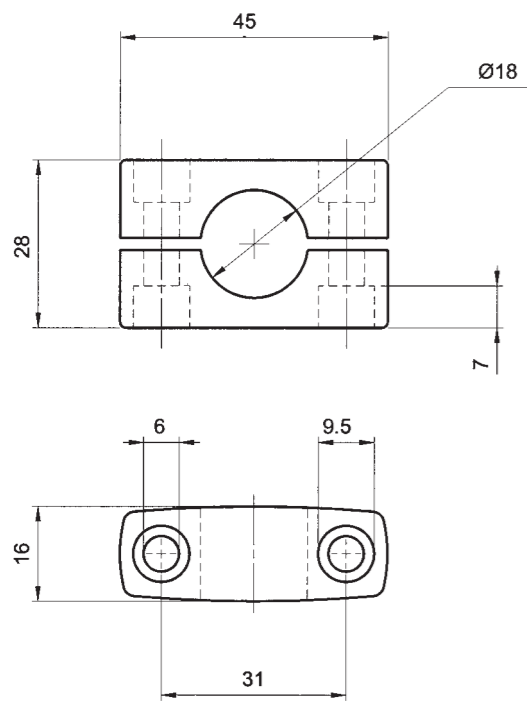

G5000001 (model MEK-PROOF)

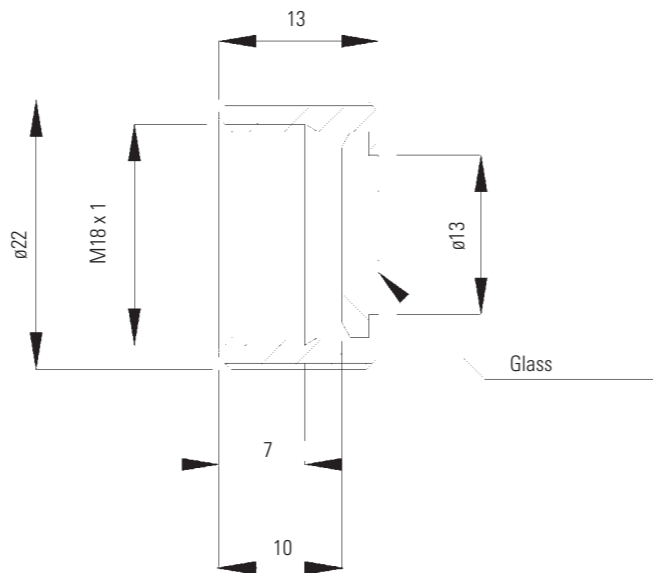

Dimensions (mm)

95ACC5350 (model JOINT-60)

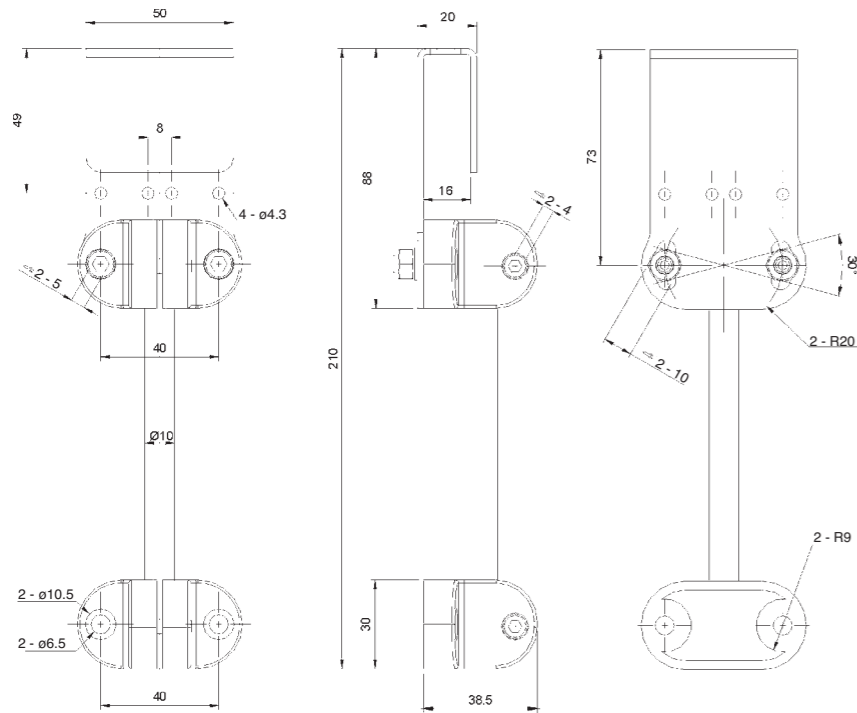

95ACC1320 (model ST-504)

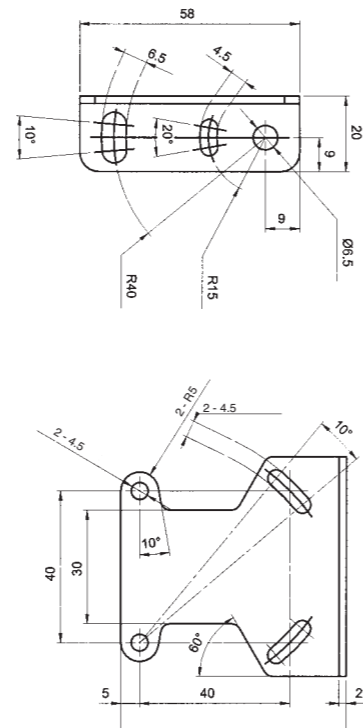

95ACC5310 (model ST-5018)

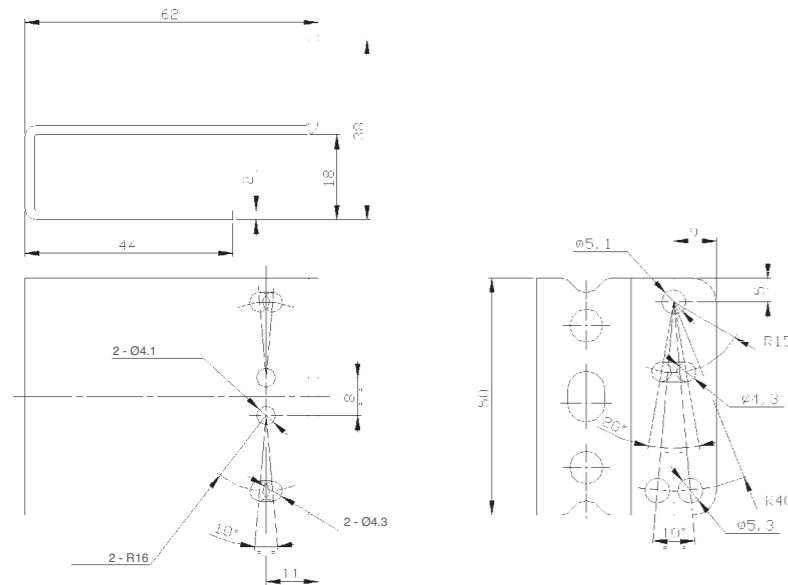

95ACC5320 (model ST-5019)

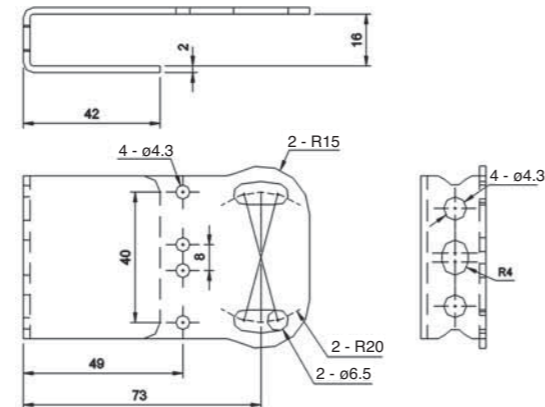

95ACC5330 (model ST-5020)

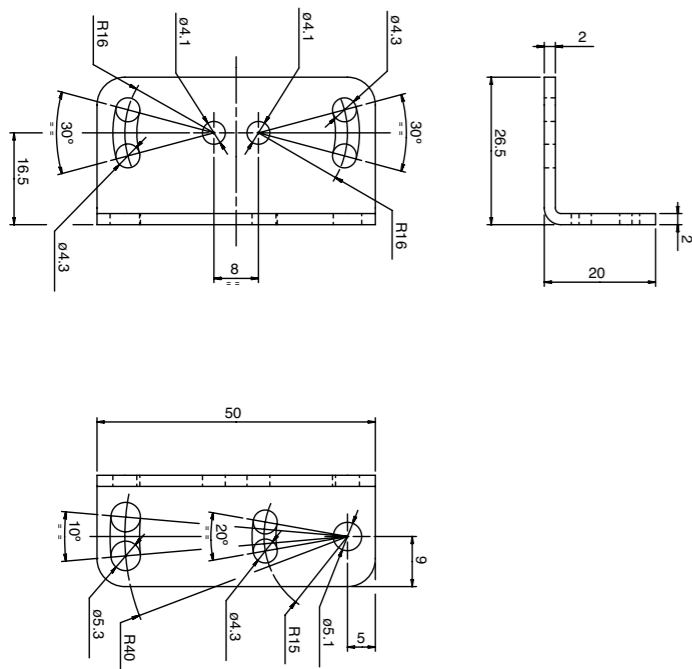

95ACC5340 (model ST-5021)

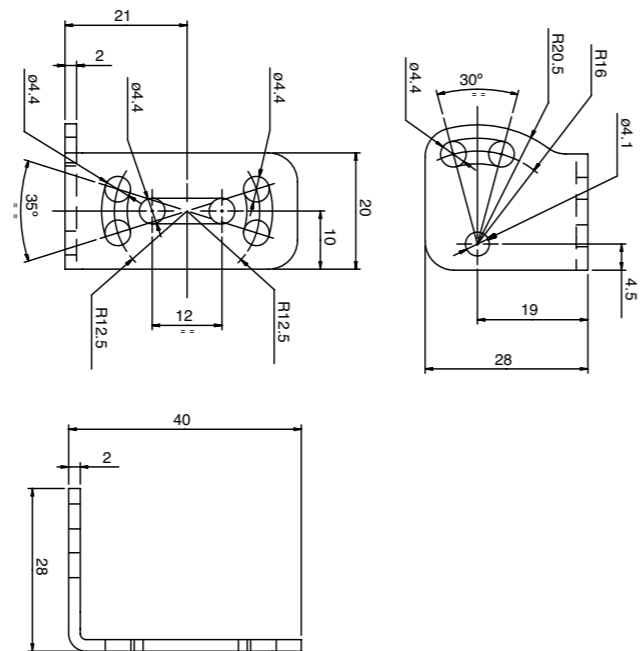

Dimensions (mm)

95ACC2410 (model ST-5053)

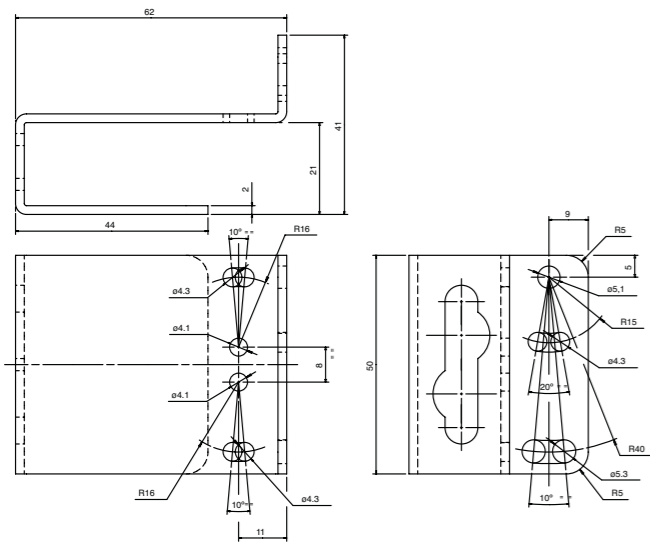

95ACC2420 (model ST-5054)

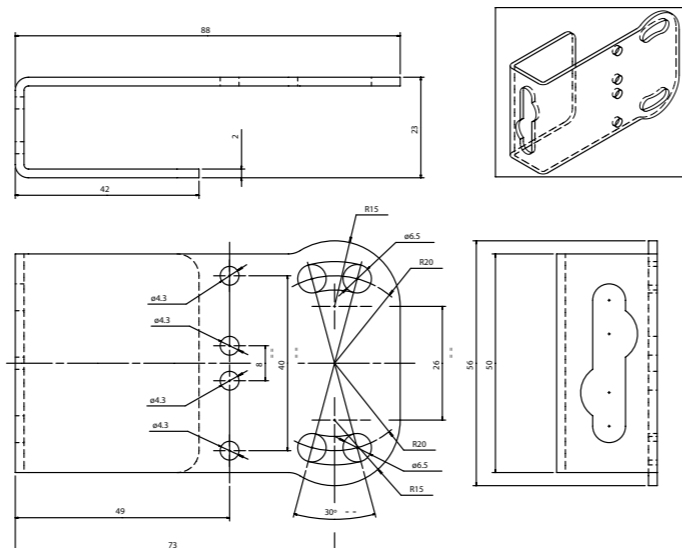

Dimensions (mm)

SA9Z-K01

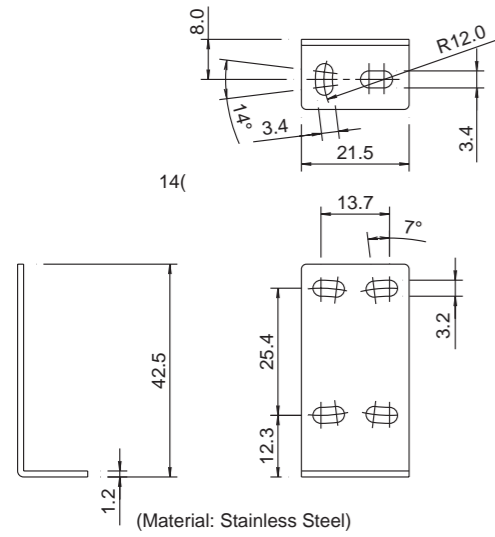

SA1E with SA9Z-K01 Mounting Bracket

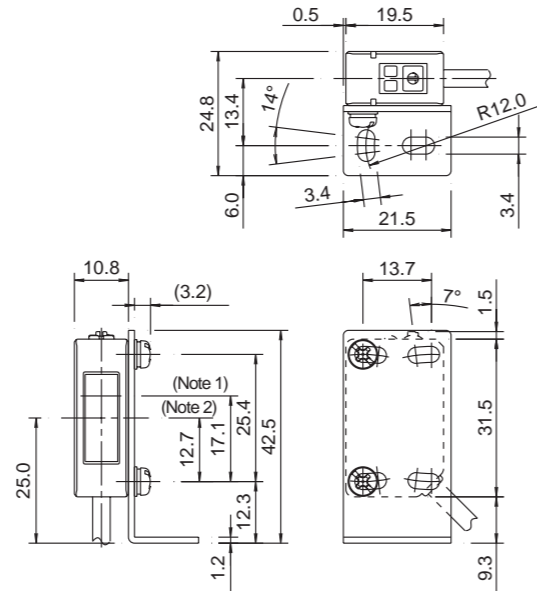

Note 1: Center of optical axis (through-beam type)
 Note 2: Center of optical axis (polarized retro-reflective, diffuse reflective, and small-beam reflective type)

SA9Z-K02

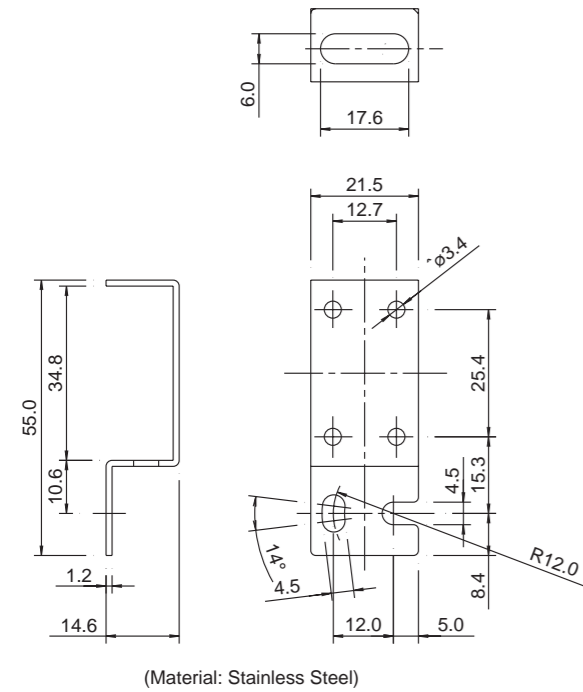

SA1E with SA9Z-K02 Mounting Bracket

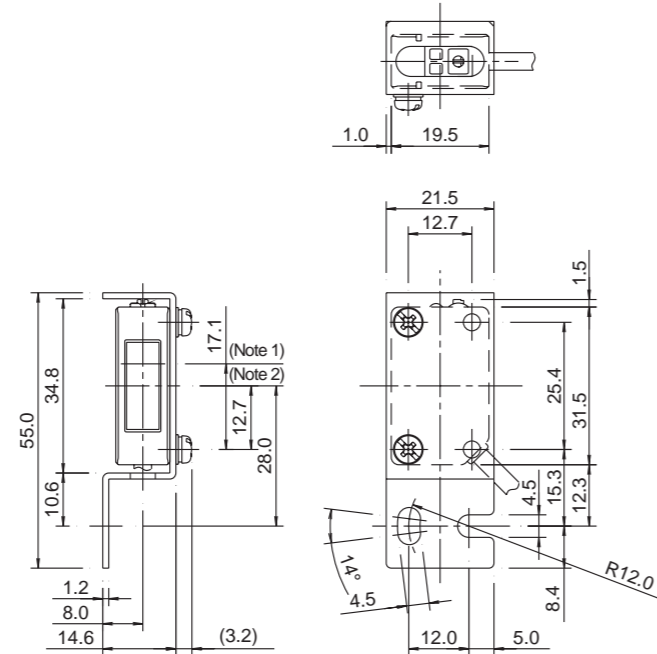

Note 1: Center of optical axis (through-beam type)
 Note 2: Center of optical axis (polarized retro-reflective, diffuse reflective, and small-beam reflective type)

Reflector Mounting Brackets

IAC-L2

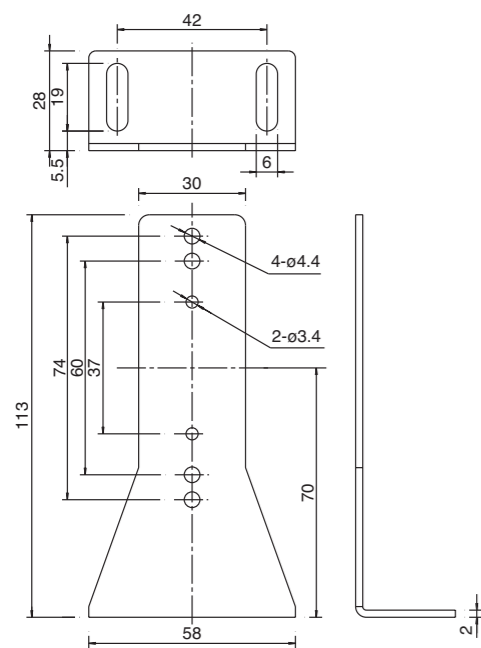

Material: SPCC (zinc chromate plating, black)

IAC-L3

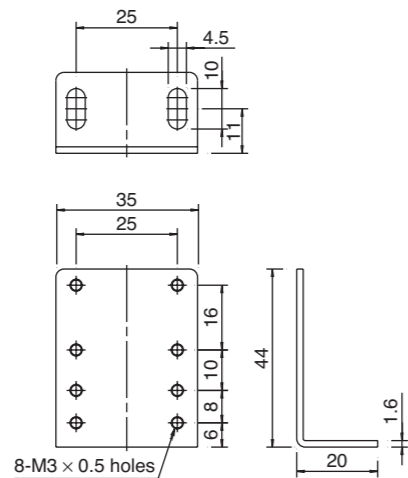

Material: SPCC (zinc plating)

Dimensions (mm)

Connector Cable (one side connector)

Straight Type

SA9Z-CM8K-4S□

- ① Black
- ② Blue
- ③ White
- ④ Brown

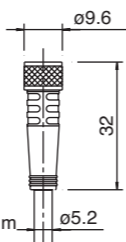

Cable length: 2 or 5 m

Note: Dielectric strength when installed on the switch
Between live part and mounting bracket: 1000V AC (except between live part and clamping ring)

Right-angle Type

SA9Z-CM8K-4L□

- ① Black
- ② Blue
- ③ White
- ④ Brown

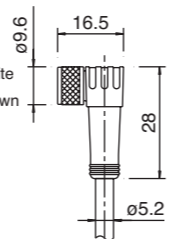

Cable length: 2 or 5 m

Note: Dielectric strength when installed on the switch
Between live part and mounting bracket: 1000V AC (except between live part and clamping ring)

Cables for SA1C-F

SA9C-CA4D2, SA9C-CA4D5

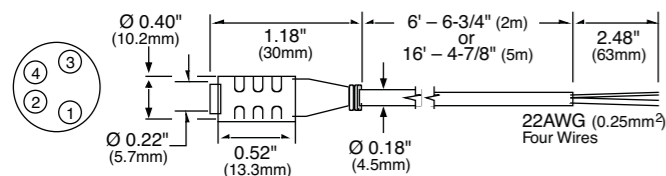

SA9C-CA4D2S, SA9C-CA4D5S

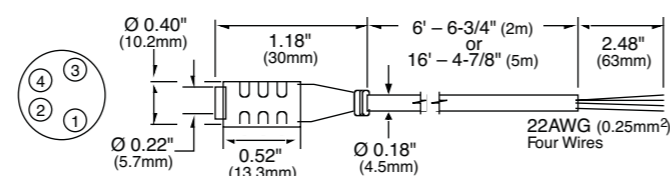

Miscellaneous Accessories

SA9Z-F01

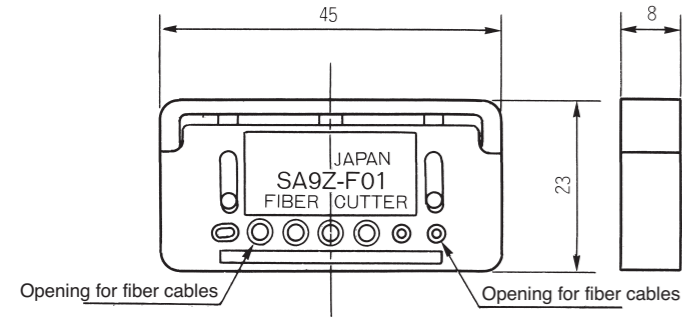

SA9Z-F02

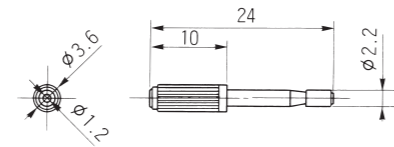

Dimensions (mm)

Attachments for Fiber Optic Sensor SA1C-F

SA9Z-F11

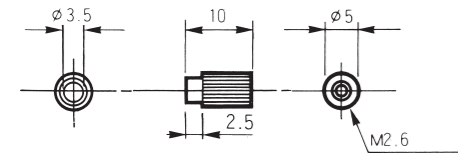

SA9Z-F12

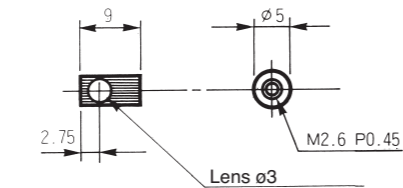

Fiber Optic Model	Distance (mm)		
	SA1C-F*	SA1C-F*G	SA1C-F1*
SA9F-TS21	1300	135	400
SA9F-TC21	1000	100	300
SA9F-TM21	1050	130	380

Fiber Optic Model	Distance (mm)	
	SA1C-F*	SA1C-F1*
SA9F-TS21	200	50
SA9F-TC21	130	35
SA9F-TM21	160	40

SA9Z-F13

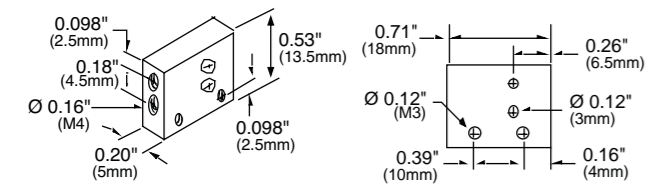

SA9Z-F14

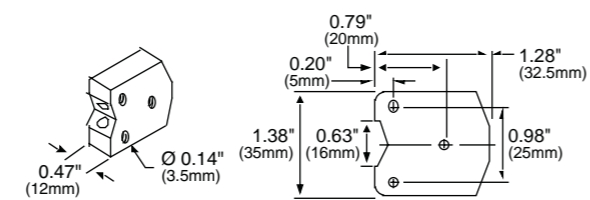

Diffuse-Reflective Light Fiber Optic Units

SA9F-DS31

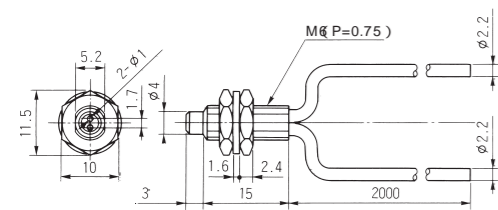

SA9F-DS32, SA9F-DS33

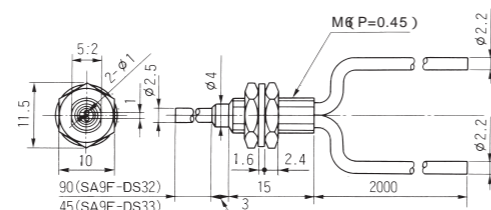

Diffuse-Reflective Light Fiber Optic Units con't

SA9F-DC31

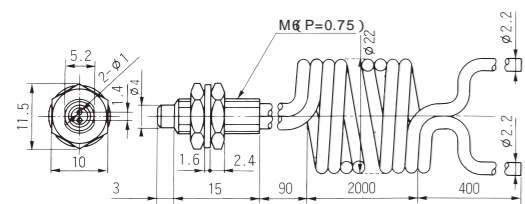

SA9F-DC32, SA9F-DC33

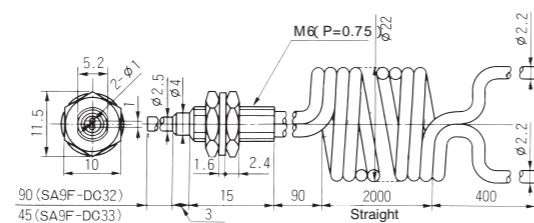

SA9F-DT11

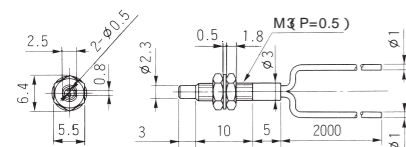

SA9F-DT12, SA9F-DT13

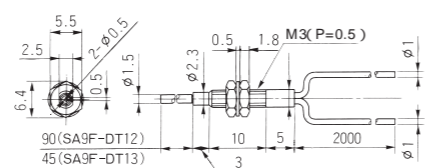

SA9F-DD31

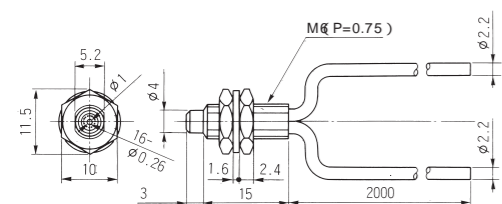

SA9F-DM74

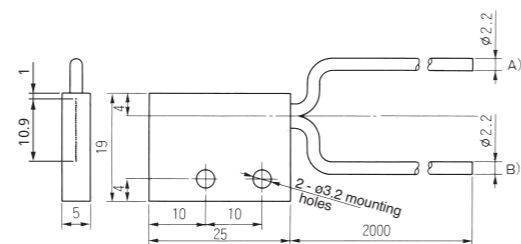

SA9F-DM75

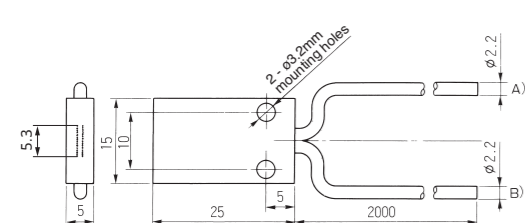

SA9F-DH21

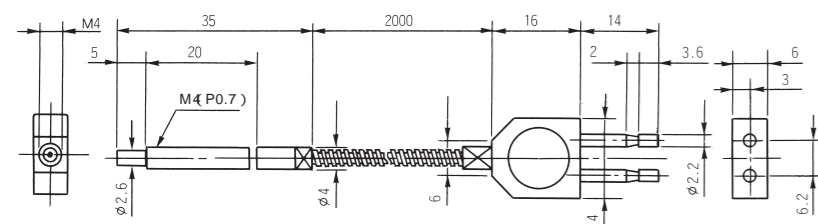

SA9F-DH22

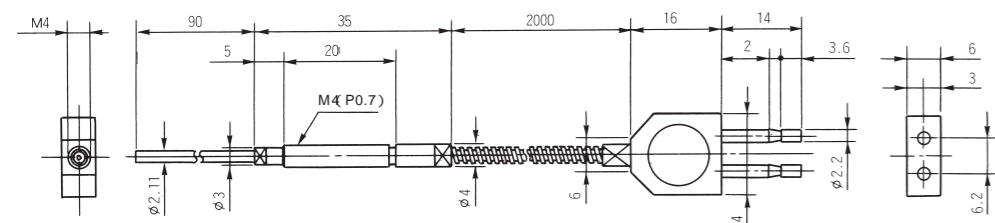

Dimensions (mm)

Diffuse-Reflective Light Fiber Optic Units con't

Dimensions (mm)

SA9F-TS21

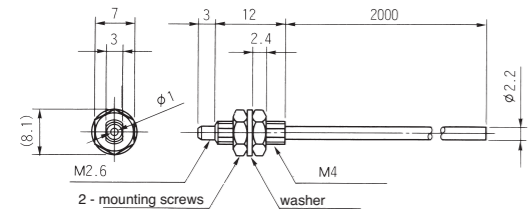

SA9F-TS23

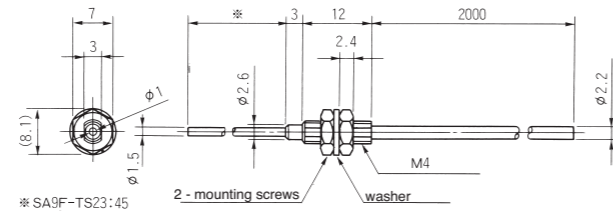

SA9F-TC21

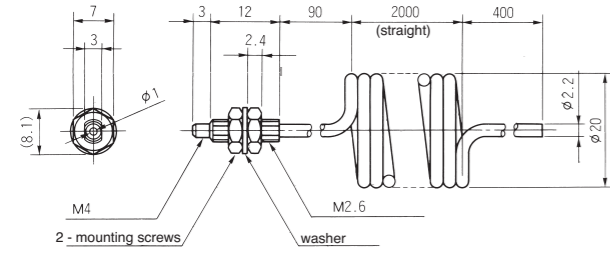

SA9F-TT11

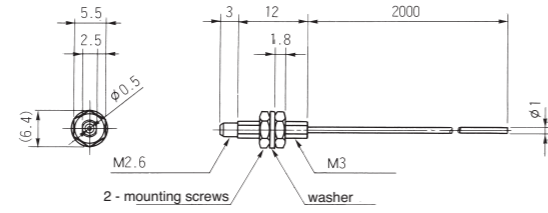

SA9F-TM21

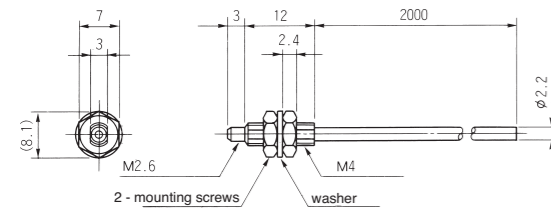

SA9F-TM22, SA9F-TM23

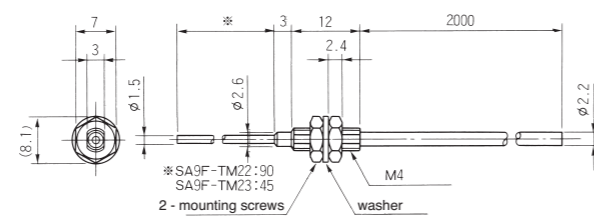

SA9F-TM74

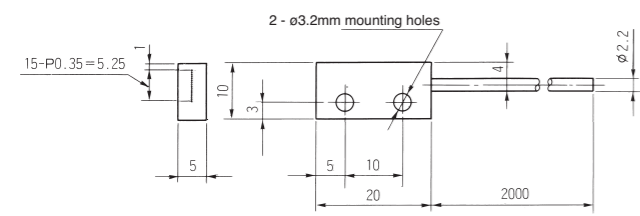

SA9F-TH21

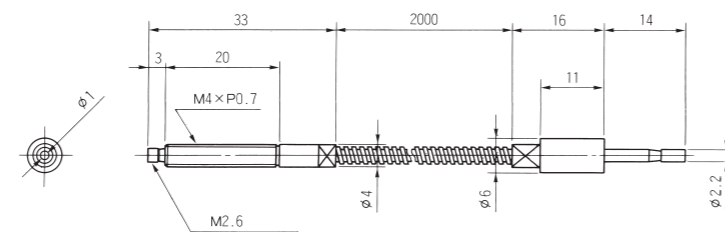

Application Sensors

Color: S65-V

Compact 50 x 50



- 3 channel color sensor with C or C+I functions and 10 tolerance levels
- White light LED emission and RGB photoreceiver
- 3 independent NPN or PNP outputs and RS485 serial interface
- 2 push-button easy setting and 4-digit display

The S65-V color sensor offers the best performance for color detection in a standard 50 x 50 x 25mm housing.

The sensor can memorize and recognize 3 colors on 3 independent channels. C (chromaticity) or C+I (chromaticity and intensity) detection algorithm and tolerance levels can be selected for each color.

Additional functions include keylock and synchronization with external events through a specific input. The control panel has two push-buttons for setting the sensor, LED outputs and a 4-digit display for messages and sensor configuration.

The S65-V color sensor can be configured in either 'C' or 'C+' detection modes. The 'C' mode is used to obtain a larger depth of field, or to detect colors on different opaque, shiny or reflecting surfaces. The 'C+' mode offers higher sensitivity towards tone variations, and is recommended for detection of different colors on the same material. It will also distinguish gray tones.



Dimensions (mm)

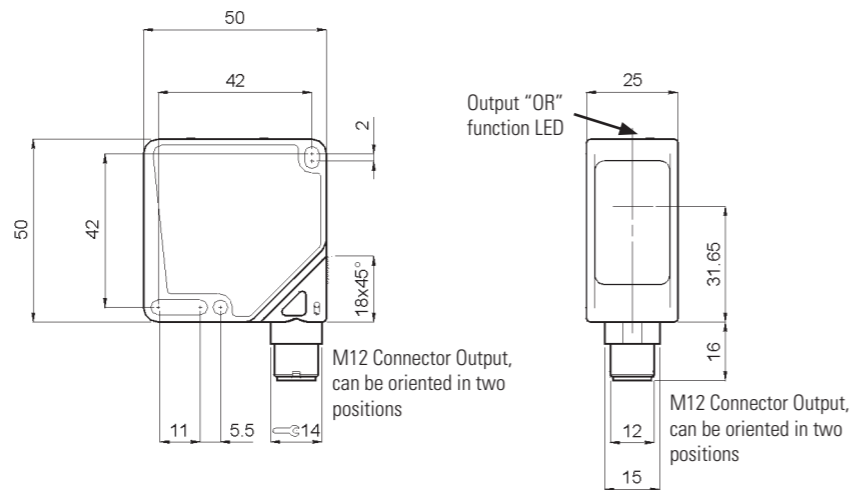

Indicators & Settings

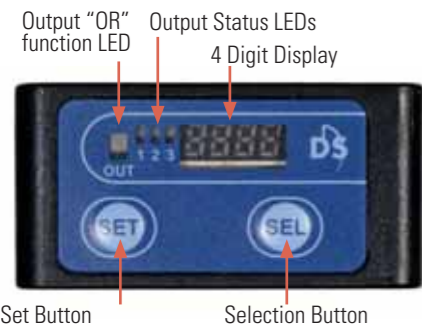

Connections

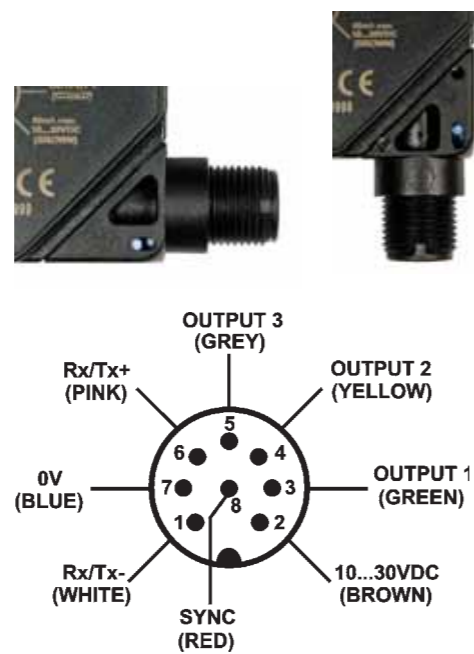

For information on accessories, see page 229.

Specifications

		S65-PA-V19-NNN	S65-PA-V19-PPP
Operating Distance	5 - 45mm *	√	√
Power Supply	10 - 30V DC ¹	√	√
Ripple	2Vpp	√	√
Current Draw	60mA at 24V	√	√
Light Emission	white LED 400 -700nm ²	√	√
Spot Dimension	approx. 4mm at 20mm	√	√
Setting	SET button	√	√
	SEL button	√	√
Indicators	4 digit display	√	√
	green active OUTPUT LEDs	√	√
	yellow 'OR' function OUTPUT LED	√	√
Output Type	PNP - NO	—	√
	NPN - NO	√	—
Output Current	≤ 100mA	√	√
Saturation Voltage	≤ 2V	√	√
Response Time	1ms (FAST); 5ms (NORM)	√	√
Switching Frequency	500Hz (FAST); 100 Hz (NORM)	√	√
Operating Mode	C or C+ independent for each channel	√	√
Tolerance Level	selectable from TOL0 to TOL9	√	√
Timing Function	selectable between 5, 10, 20, 30 & 40ms	√	√
Auxiliary Functions	ext. synchronism	√	√
	keylock ³	√	√
Connection	M12 8-pole connector ⁴	√	√
Electrical Protection	class 2	√	√
Mechanical Protection	IP67	√	√
Protection Devices	A, B ⁵	√	√
Housing Material	ABS	√	√
Lens Material	glass	√	√
Weight	100g max.	√	√
Operating Temperature	-10 to +55°C	√	√
Storage Temperature	-25 to +70°C	√	√
Reference Standard	EN60947-5-2, UL508	√	√



* Refer to detection diagram on next page.

1. Limit values
2. Average life of 100,000 hrs with T_a = +25 °C
3. Is activated with SYNC connected to +V at power up
4. Connector can be locked in two different positions
5. A - reverse polarity protection
B - overload and short-circuit protection

Detection Diagram
Operating Distance According to Target Reflectivity Degree

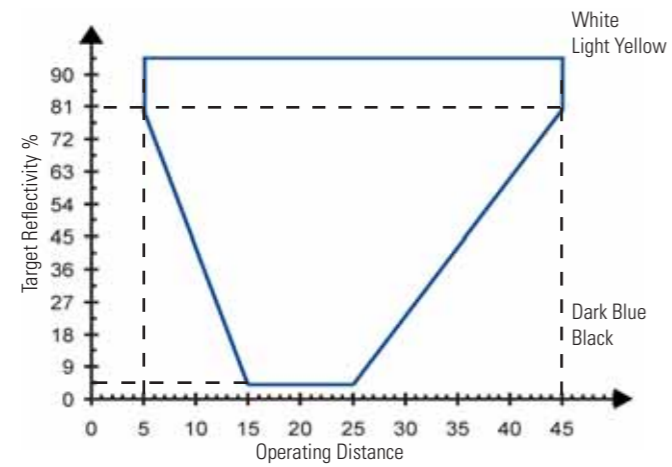

Part Numbers

Function	Connection	Output	RS485	Part Number
 Color Sensor	M12 connector	NPN	—	S65-PA-5-V19-NNN
Color Sensor	M12 connector	PNP	—	S65-PA-5-V19-PPP

For information on accessories, see page 229.



Additional models are available. Visit www.idec-ds.com for more information.

Connector Cable (for connector model sensors)

Appearance	Type & Length	Use with	Part No.
	5m axial 8-pole M12 cable	S65, S80	CS-A1-06-B-05

Color: SA1J/SA1J-F

Full Color Sensors



- Choice of a 3-color version or a 1-color version
- Fast response (0.3ms)—perfect for sensing complex color marks at high speed
- Three LEDs (Red, Green, and Blue) provide a long life
- Set sensor with the touch of a button
- Highly sensitive to variations in color; can distinguish between subtle shades of the same color
- IP67

SA1J:

- Easy alignment and targeting using a visible spot
- Up to 60mm sensing distance

SA1J-F

- Wide assortment of fiber optic heads fit in tight mounting areas

The SA1J series of sensors are a proven leader among inexpensive color recognition sensors. With a high response speed of 0.3msec and superb color discriminating electronics, the SA1J full color sensor is the perfect solution for almost any color detection application.

This full color sensor is simple to program. You literally just touch a button and your target reference color is programmed. With the SA1J's small visible beam spot, this sensor is easy to align in complex applications.

The SA1J is available in 1- or 3-color models. The SA1J 3-color sensor offers users the added benefit of three reference color registration and three individual outputs. This is ideal for multiple color registration.

The SA1J-F is also ideal for color sorting and quality control applications where space is limited. The SA1J-F can utilize a wide assortment of fiber optic heads to fit in the smallest of mounting areas. The SA1J-F offers both one and three color programmable sensors for multiple-color sorting applications. With the touch of a button, the SA1J-F is programmed and ready to take on difficult applications.

Full Color Recognition Sensor - SA1J

Dimensions (mm)

A cost-effective solution for full color sensing applications—IDEC's SA1J full color recognition sensor. Outstanding benefits of the SA1J include an extremely high response speed (0.3ms) and high resolution.

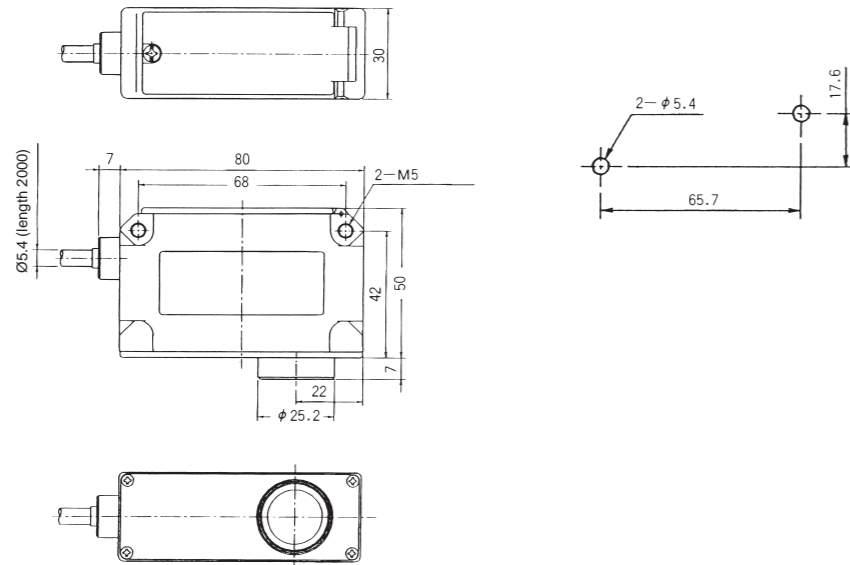

Specifications

		1-Color Version				3-Color Version					
		SA1J-C1N1	SA1J-C1P1	SA1J-C2N1	SA1J-C2P1	SA1J-C1N3	SA1J-C1P3	SA1J-C2N3	SA1J-C2P3		
General Specifications	Power Voltage	12 to 24V DC (ripple 10% maximum) Operating voltage: 10 to 30V DC		✓	✓	✓	✓	✓	✓	✓	✓
	Current Draw	150mA maximum		✓	✓	✓	✓	✓	✓	✓	✓
	Dielectric Strength	Between live and dead parts: 1,000V AC, 1 minute		✓	✓	✓	✓	✓	✓	✓	✓
	Insulation Resistance	Between live and dead parts: 20M Ω minimum (500V DC megger)		✓	✓	✓	✓	✓	✓	✓	✓
	Operating Temperature	-10 to +50°C (performance will be adversely affected if the sensor becomes coated with ice)		✓	✓	✓	✓	✓	✓	✓	✓
	Operating Humidity	35 to 85% RH (avoid condensation)		✓	✓	✓	✓	✓	✓	✓	✓
	Storage Temperature	-30 to +70°C		✓	✓	✓	✓	✓	✓	✓	✓
	Vibration Resistance	Damage limits: 10 to 55Hz Single amplitude: 0.75mm 2 hours in each of 3 axes		✓	✓	✓	✓	✓	✓	✓	✓
	Shock Resistance	Damage limits: 500m/s ² (approximately 50G) 5 shocks in each of 3 axes		✓	✓	✓	✓	✓	✓	✓	✓
	Extraneous Light Immunity	Sunlight: 10,000 lux maximum Halogen lamp: 3,000 lux maximum		✓	✓	✓	✓	✓	✓	✓	✓
	Material	Housing: Aluminum Lens: Glass Cover: Polycarbonate		✓	✓	✓	✓	✓	✓	✓	✓
	Degree of Protection	IP67—IEC Pub 529		✓	✓	✓	✓	✓	✓	✓	✓
	Cable	Cable type: $\phi 5.4$ mm 5-core oiltight vinyl cable (0.2mm ²) 2m long		✓	✓	✓	✓	-	-	-	-
		Cable type: $\phi 5.4$ mm 7-core oiltight vinyl cable (0.2mm ²) 2m long		-	-	-	-	✓	✓	✓	✓
	Weight	Approximately 250g		✓	✓	✓	✓	✓	✓	✓	✓
	Dimensions (HxWxD)	1.97" x 1.18" x 3.15" (50 x 30 x 80mm)		✓	✓	✓	✓	✓	✓	✓	✓
Accessories	Adjusting screwdriver		✓	✓	✓	✓	✓	✓	✓	✓	



	1-Color Version	3-Color Version	
Function Specifications	Reference Color Registration	<p>Push SET button (sensor aimed at color target); sensor records reference color in EEPROM memory</p>	<p>Set dial to A: Push SET button (sensor aimed at color target A); sensor records reference color A in EEPROM memory Set dial to B: Push SET button (sensor aimed at color target B); sensor records reference color B in EEPROM memory Set dial to C: Push SET button (sensor aimed at color target C); sensor records reference color C in EEPROM memory</p>
	Tolerance	Digital setting for 5 degrees of inspection sensitivity	Digital setting for 5 degrees of inspection sensitivity (normal run mode only)
	Inspection Mode	Selectable: Color component only (C) or color component plus intensity (C+I) (depth of color)	
	Operation Mode	—	<p>Selectable: S run: Auto select, sensor determines tolerance (no need to set tolerance) Normal run mode: Manually select tolerance (1–5) for each reference color</p>
	Synchronous Mode	Selectable: Internal response mode or synchronized with an external signal	
	Response Mode	High-speed (F): 0.3ms Normal speed (N): 1ms Slow speed (S): 5ms	High-speed (F): 0.8ms Normal speed (N): 1.5ms Slow speed (S): 6ms
	Control Output	On: Detected color matches target color NPN or PNP transistor open collector 30V DC, 100mA maximum Residual: 1.5V maximum, short circuit protection	<p>Control output A on: Detected color corresponds to target color A* Control output B on: Detected color corresponds to target color B* Control output C on: Detected color corresponds to target color C*</p> NPN or PNP transistor open collector 30V DC, 100mA maximum Residual: 1.5V maximum, short circuit protection
	Operation LED	On: When control output is on (yellow LED)	
	Off-Delay Timer	Selectable: Timer ON (T-ON) or Timer OFF (T-OFF)	
	Timer	OFF delay timer 40ms	
	SET Input	<p>NPN: 30V DC maximum/3.6mA (when connected to 0V) Typical operating voltage: (0V) +4V maximum</p>	<p>NPN: 30V DC maximum/3.6mA (when connected to 0V) Typical operating voltage: (0V) +4V maximum</p>
	External Synchronous Input	<p>PNP: 30V DC maximum/3mA (when connected to 24V) Typical operating voltage: (+V) –4V maximum</p>	<p>PNP: 30V DC maximum/3mA (when connected to 24V) Typical operating voltage: (+V) –4V maximum</p>
	Light Source	3 LEDs (Red, Green, Blue)	



1. Each channel has its own independent short circuit protection.
2. *The target color is defined by the operation mode setting.

Full Color Fiber Optic Sensor - SA1J-F

Dimensions

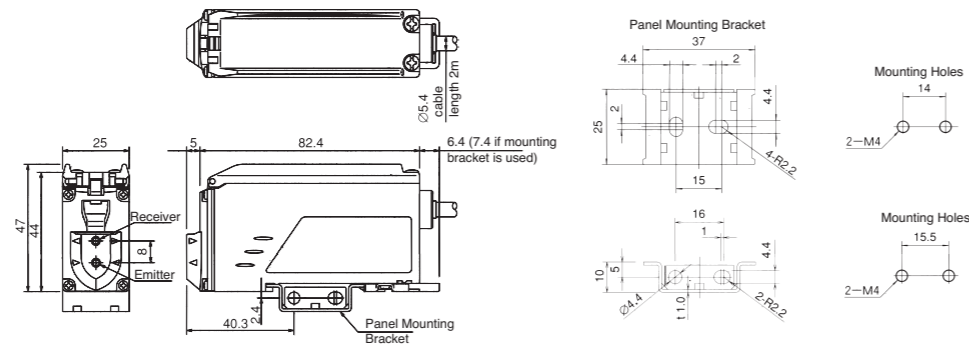

This line of full color sensors offers IDEC's proven color sensing technology in a fiber optic version. The SA1J-F is ideal for color sorting and quality control applications where space is limited. The SA1J-F utilizes a wide assortment of fiber optic heads to fit in the smallest of mounting areas. This product line offers both 1- and 3-color programmable sensors for multiple color sorting applications. With the touch of a button, the SA1J-F is programmed and ready to work. The SA1J-F also has a remote lead for programming by a remote PLC or switch.



Specifications

		1-Color Version		3-Color Version					
		SA1J-F1N1	SA1J-F1P1	SA1J-F1N3	SA1J-F1P3				
General Specifications	Power Voltage	12 to 24V DC (ripple 10% maximum) Operating voltage: 10 to 30V DC				√	√	√	√
	Current Draw	150mA maximum				√	√	√	√
	Dielectric Strength	Between live and dead parts: 1,000V AC, 1 minute				√	√	√	√
	Insulation Resistance	Between live and dead parts: 20MΩ minimum (500V DC megger)				√	√	√	√
	Operating Temperature	-10 to +50°C (no freezing)				√	√	√	√
	Operating Humidity	35 to 85% RH (avoid condensation)				√	√	√	√
	Storage Temperature	-30 to +70°C				√	√	√	√
	Vibration Resistance	Damage limits: 10 to 55Hz Single amplitude: 0.75mm 2 hours in each of 3 axes				√	√	√	√
	Shock Resistance	Damage limits: 500m/s ² (approximately 50G) 5 shocks in each of 3 axes				√	√	√	√
	Extraneous Light Immunity	Sunlight: 10,000 lux maximum Incandescent lamp: 3,000 lux maximum				√	√	√	√
	Material	Housing: Aluminum Lens: Glass Cover: Polyarylate				√	√	√	√
	Degree of Protection	IP65 (when inserting the fiber unit and tightening the cover)				√	√	√	√
	Cable	0.2mm ² ø5.4mm 5-core vinyl cabtyre cable, 2m long				√	√	-	-
		0.2mm ² ø5.4mm 7-core vinyl cabtyre cable, 2m long				-	-	√	√
Weight	Approximately 190g				√	√	√	√	
Dimensions (HxWxD)	47H x 25W x 82.4D mm				√	√	√	√	
Accessories	Mounting bracket				√	√	√	√	
	Adjusting screwdriver				√	√	√	√	



		1-Color Version		3-Color Version		
		SA1J-F1N1	SA1J-F1P1	SA1J-F1N3	SA1J-F1P3	
Function Specifications	Reference Color Set	Teaching system, 1-color	√	√	–	–
		Teaching system, 3-colors	–	–	√	√
	Inspection Tolerance	5-step digital setting	√	√	√	√
	Inspection Mode	Color (C) / Color + Intensity (C+1)	√	√	√	√
	Operation Mode	Normal Run Mode (1 to 5)	√	√	–	–
		Normal Run Mode (1 to 5) Select Run Mode	–	–	√	√
	Synchronous Mode	Internal Synchronous Mode (INT) / External Synchronous Mode (EXT)	√	√	√	√
	Response Mode	Fast (F) / Normal (N) / Slow (S)		√	√	√
	OFF-delay Timer	Timer On (T-ON) / Timer Off (T-OFF)	√	√	√	√
	Control Output	NPN open collector 30V DC, 100mA maximum Voltage Drop 1.5V maximum Protected against short circuit	√	–	√	–
		PNP open collector 30V DC, 100mA maximum Voltage Drop 1.5V maximum Protected against short circuit	–	√	–	√
	SET input/ External Synchronous Input	30V DC maximum / 3.6mA (when connected to 0V) Typical Operating Voltage: (0V) + 4V maximum	√	–	√	–
		30V DC maximum / 3.0mA (when connected to 24V) Typical Operating Voltage: (+V) - 4V maximum	–	√	–	√
	Operation Indicator	Yellow LED	√	√	–	–
		Yellow LED (3-color individual display)	–	–	√	√
	Timer	OFF-delay timer 40 msec	√	√	√	√
	Output Operation	Equivalent Output	√	√	√	√
	Response Time	FAST (0.3 msec), NORMAL (1 msec), SLOW (5 msec) selectable	√	√	–	–
FAST (0.8 msec) NORMAL (1.5 msec) SLOW (6 msec) selectable		–	–	√	√	
Light Source	Three LEDs (red, green, blue)	√	√	√	√	

Part Numbers

SA1J

Function	Spot Diameter	Sensing Distance	Inspection Spot	Output	Part Numbers			
					1-Color Versions	3-Color Versions		
	ø4mm (ø0.157") ø6mm (ø0.236") ø8mm (ø0.315")	40mm (1.575") 50mm (1.969") 60mm (2.362")	Standard	NPN	SA1J-C1N1	SA1J-C1N3		
					Small	PNP	SA1J-C1P1	SA1J-C1P3
							NPN	SA1J-C2N1
	PNP	SA1J-C2P1	SA1J-C2P3					

SA1J-F

Function	Type	Output Type	Part Numbers
	1-color	NPN open collector	SA1J-F1N1
	3-color	30V DC, 100mA	SA1J-F1N3
	1-color	PNP open collector	SA1J-F1P1
	3-color	30V DC, 100mA	SA1J-F1P3

For information on accessories, see page 229.

Applications

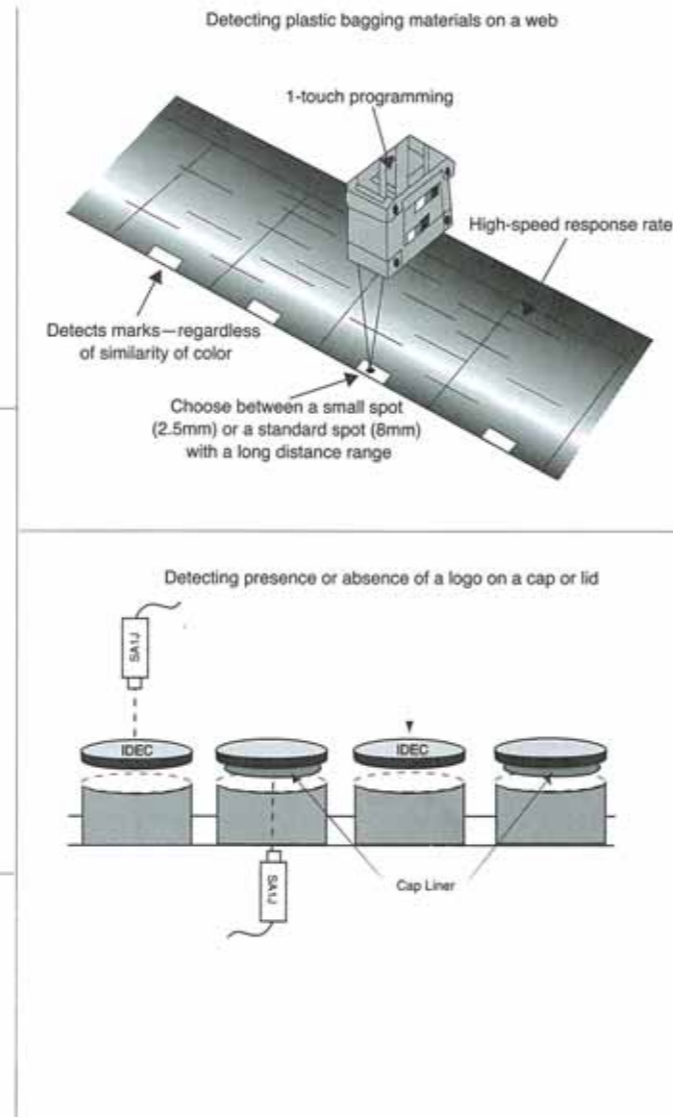
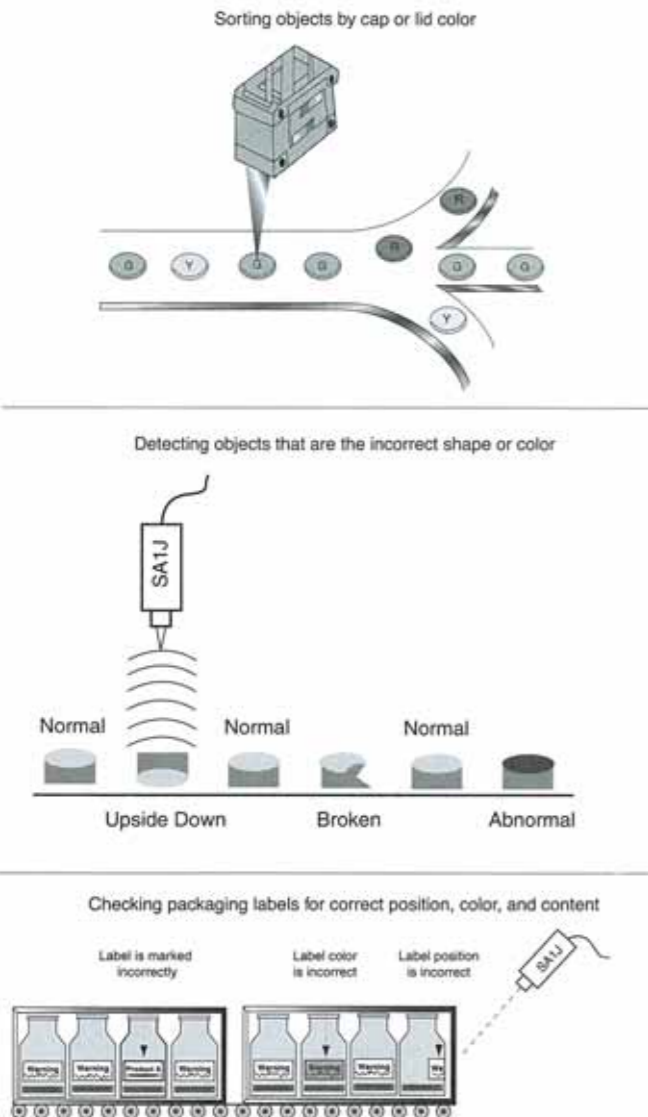

Contrast: TL46

Digital Contrast Sensor with Metal Housing

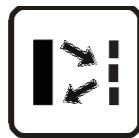

- RGB LED
- Automatic, manual and remote setting
- 20kHz switching frequency
- NPN/PNP and analog outputs
- Standard mounting, M12 connector rotates in 5 positions

The TL46 digital contrast sensor is characterized in terms of resolution, definition and precision of the light spot emitted by RGB LEDs, fast response time and high switching speed. The sensor, developed in a sturdy metal housing with standard mounting, is available for applications requiring innovative technology at the best price/performance ratio.

The TL46-WL has 3 push-buttons to set the sensor, 4 LEDs signaling the output status, sensor acquisition condition, delay output activation and push-button activation. A bar graph is also available for manual setting of the threshold to detect particularly difficult contrasts. It also has a 20kHz switching frequency.

Accessory lenses with 9 - 40mm focal distance are available, as well as a high-resolution focusing lens and a PMMA plastic lens particularly suitable for food applications with standard 9mm focal distance.

Setting

The switching threshold is set by pressing twice on the SET button; the first for the mark, the second for the background. The threshold level can also be set manually by pressing the '+' and '-' buttons, which increase or reduce the threshold as shown on the bar graph or display.



Dimensions (mm)

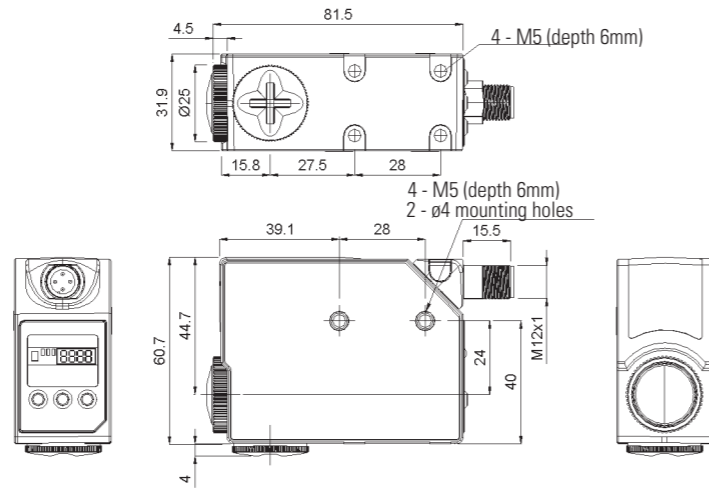

Indicators & Settings

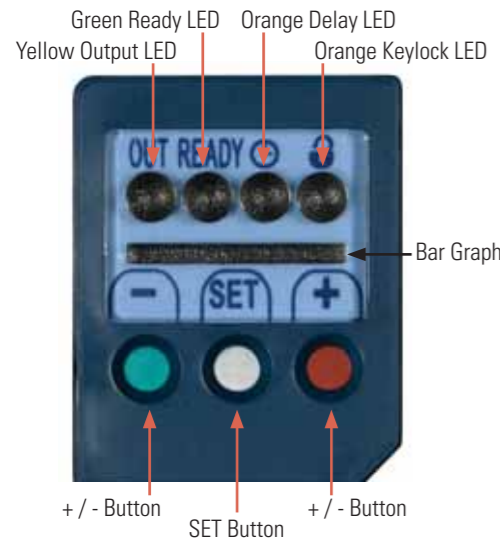

Connection

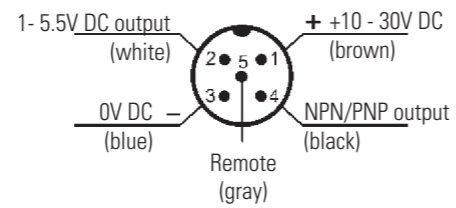

An M12 4-pole connector can be used if PIN5 function is not necessary.

Specifications

		TL46-WL-815
Power Supply	10 - 30 V DC ¹ , reverse polarity protection	√
Current Draw	85mA max.	√
Light Emission	RGB LED (630nm red, 520nm green, 465nm blue) ²	√
Spot Dimension	1.5 x 5mm (with standard 9mm lens)	√
Spot Orientation	Vertical	√
Operating Distance	6 - 12mm (with standard 9mm lens)	√
Depth Of Field	± 3 mm (with standard 9mm lens)	√
Setting	Automatic / manual / remote	√
Indicators	Yellow OUTPUT LED	√
	Green ready LED	√
	Orange delay LED	√
	Orange keylock LED	√
	5-segment bargraph	√
Output Type	NPN/PNP programmable	√
Output Current	100 mA max.	√
Saturation Voltage	≤ 2 V	√
Response Time	25μs	√
Switching Frequency	20kHz	√
Operating Mode	Dark/light selectable	√
Analog Output	0 - 5.5V (3V on 90% white)	√
Timing Function	20ms programmable	√
Auxiliary Functions	Keylock	√
Connections	M12 5-pole connector 3 ³	√
Electrical Protection	Class 2, double insulation	√
Mechanical Protection	IP67	√
Protection Devices	A, B ⁴	√
Housing Material	Aluminum	√
Lens Material	Glass	√
Weight	170g max.	√
Operating Temperature	-10 to 55°C	√
Storage Temperature	-20 to 70°C	√
Reference Standard	EN60947-5-2, UL508	√

Vertical Spot



1. Limit values
2. Average life of 100,000 hrs with T_a = +25 °C
3. Connector block can rotate to 5 positions
4. A - reverse polarity protection
B - overload and short-circuit protection

Detection Diagrams

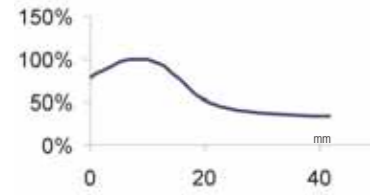
9mm Standard Lens
(1.5 x 5mm spot at focal point)

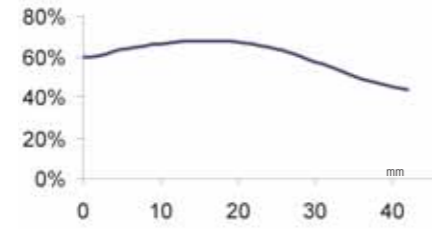

18mm Accessory Lens
(2 x 7mm spot at focal point)



22mm Accessory Lens
(2 x 8mm spot at focal point)

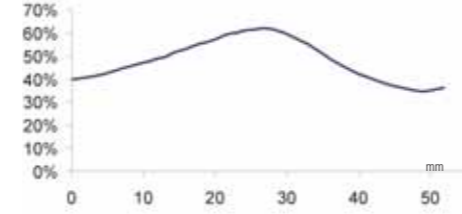

28mm Accessory Lens
(2 x 9mm spot at focal point)

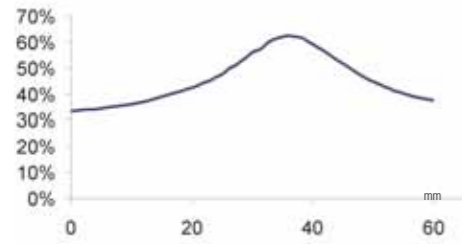

40mm Accessory Lens
(2.4 x 11mm spot at focal point)

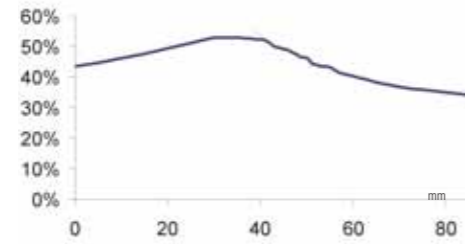

Part Number

Function	Version	Spot	Part Number
	Standard	Vertical	TL46-WL-815

For information on accessories, see page 229.

Additional models are available. Visit www.idec-ds.com for more information.

Connector Cables (for connector model sensors)

Appearance	Type & Length	Use with	Part No.
	5m axial 5-pole M12 cable	TL46, LD46, DS1 (receiver), AS1 (receiver)	CS-A1-03-G-05

Luminescence: LD46
UV LED Emission Sensors



- UV luminescent mark detection
- High-powered UV emission for improved sensitivity
- Fast switching frequency and response time
- Easy setting with a clear bar graph indicator

Luminescence sensors emit ultraviolet (UV) light and receive visible light reflected from luminescent surfaces. This technology allows the detection of fluorescent marks (even invisible to the human eye) on any object independent of its material, color or distance, inside the operating range. In addition, it ignores light interference or reflections from non-luminescent surfaces, like glass, mirrors or shiny metal surfaces.

Luminescence sensors can be utilized in many different applications. For example, in pharmaceutical and cosmetic industries they can detect labels on glass vials or bottles, or verify packaging. They can be used to check fluorescent selection marks in woodworking and ceramic tile production; detect whitened paper or fluorescent glues in automatic packaging, and identify fluorescent cutting guides or labels in textile industries. In addition, they can be used to verify fluorescent paints, lubricants, gaskets or fittings in mechanical industries; or check money and credit cards in vending machines or cash dispensers. The high power and shape of the LD46 sensor light spot enable the detection of critical targets with a very poor, non-homogeneous or low luminescent light level, such as raw wood, corrugated cartons, fabric or ceramic tiles.

The switching threshold can easily be set by pressing the '+' and '-' buttons that increase or decrease the sensitivity level that can be seen on the bar graph indicator. The sensor has a KEYLOCK function that deactivates the keyboard preventing accidental sensor setting. The keyboard is locked when the sensor is turned on and can be activated by pressing the SET button for 5 seconds until the keylock LED turns on. The keyboard automatically locks again if not used for 2 minutes.



Dimensions (mm)

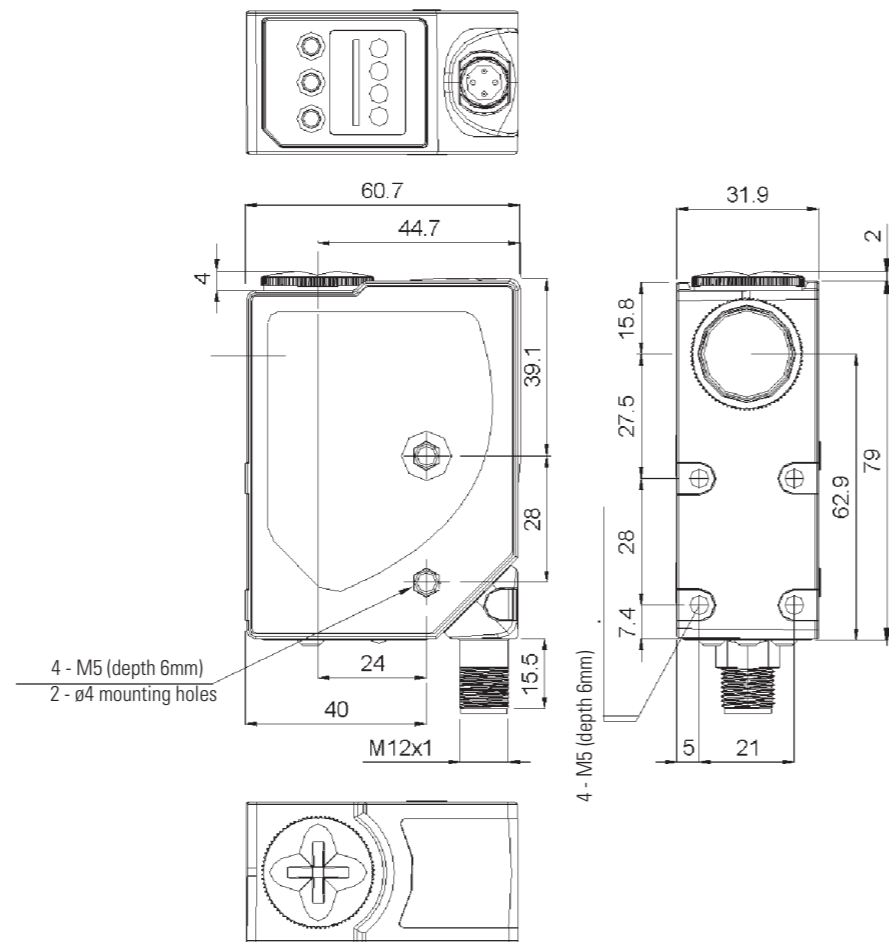

Indicators & Settings

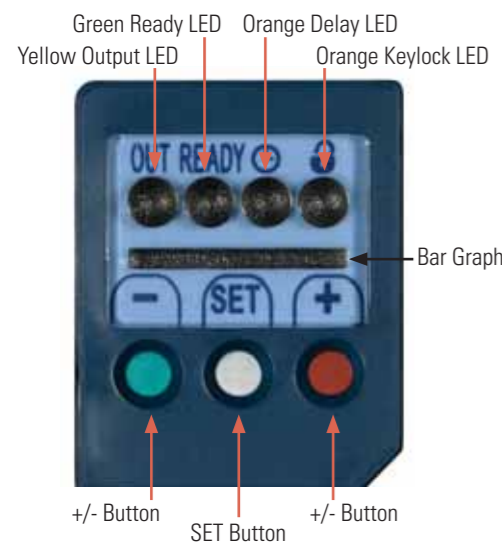

Connection

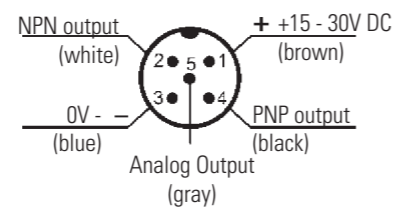

Specifications

		LD46-UL-715
Power Supply	15 - 30V DC, reverse polarity protection	✓
Current Draw	50mA max at 24V DC	✓
Light Emission	UV LED, 375nm ¹	✓
Spot Dimension	2 x 8mm at 10mm	✓
Operating Distance	10 - 20mm	✓
Setting	Manual using '+', '-' and SET push-buttons	✓
Indicators	Yellow OUTPUT LED	✓
	Green ready LED	✓
	Orange delay LED	✓
	Orange keylock LED	✓
	5-segment bar graph	✓
Output Type	NPN	✓
	PNP	✓
Output Current	100 mA max.	✓
Saturation Voltage	≤ 2V	✓
Response Time	250µs	✓
Switching Frequency	2kHz	✓
Operating Mode	Light	✓
Analog Output	0.75 - 5.5V max.	✓
Timing Function	20ms selectable	✓
Auxiliary Functions	Keylock	✓
Connections	M12 5-pole connector ²	✓
Electrical Protection	Double insulation	✓
Mechanical Protection	IP67	✓
Protection Devices	A, B ³	✓
Housing Material	Aluminum	✓
Lens Material	Glass	✓
Weight	180 g max.	✓
Operating Temperature	-10 to 55°C	✓
Storage Temperature	-20 to 70°C	✓
Reference Standard	EN60947-5-2, UL508	✓

Light Spot

The UV emission power and the sharpness of the light spot enable the detection of critical targets with very poor or non-homogeneous luminescence level.



UL Pending



1. Average life of 100,000 hrs with T_a = +25 °C
2. Connector block can rotate to 2 positions
3. A - reverse polarity protection
B - overload and short-circuit protection

Detection Diagrams

9mm Standard Lens

(2 x 8mm spot size at 10mm)

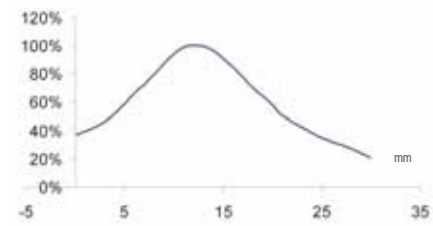
**22mm Standard Lens**

(3 x 11mm spot size at 24mm)

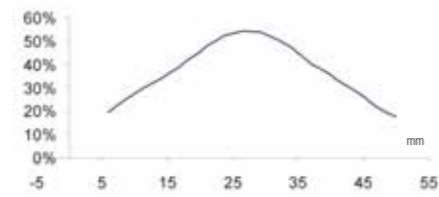
**40mm Standard Lens**

(4 x 15mm spot size at 50mm)

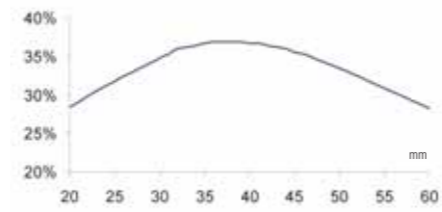

Part Number

Function	Operating Distance	Part Number
	10 - 20 mm	LD46-UL-715

For information on accessories, see page 229.



Additional models are available. Visit www.idec-ds.com for more information.

Connector Cables (for connector model sensors)

Appearance	Type & Length	Use with	Part No.
	5m axial 5-pole M12 cable	TL46, LD46, DS1 (receiver), AS1 (receiver)	CS-A1-03-G-05

Fork/Slot: SR21

Micro-processor Based Slot Sensors For Labeling & Packaging

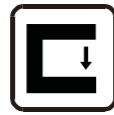

- High 25kHz switching frequency
- Red/green light models
- Detection of semi-transparent labels
- Detection of registration marks on semi-transparent labels
- 4-wire independent NPN and PNP output

The SR21 series slot sensors, with a 2mm slot width, provide a 12-bit (4096 step) resolution, a 20µs response time and a switching frequency of 25kHz.

The setting of the switching threshold is carried-out by simply pressing a button, or dynamically during label (or other reference) movement.

The SR21-RG model with double red or green light is ideal for print registration mark detection on transparent films for automatic packaging.

Dimensions (mm)

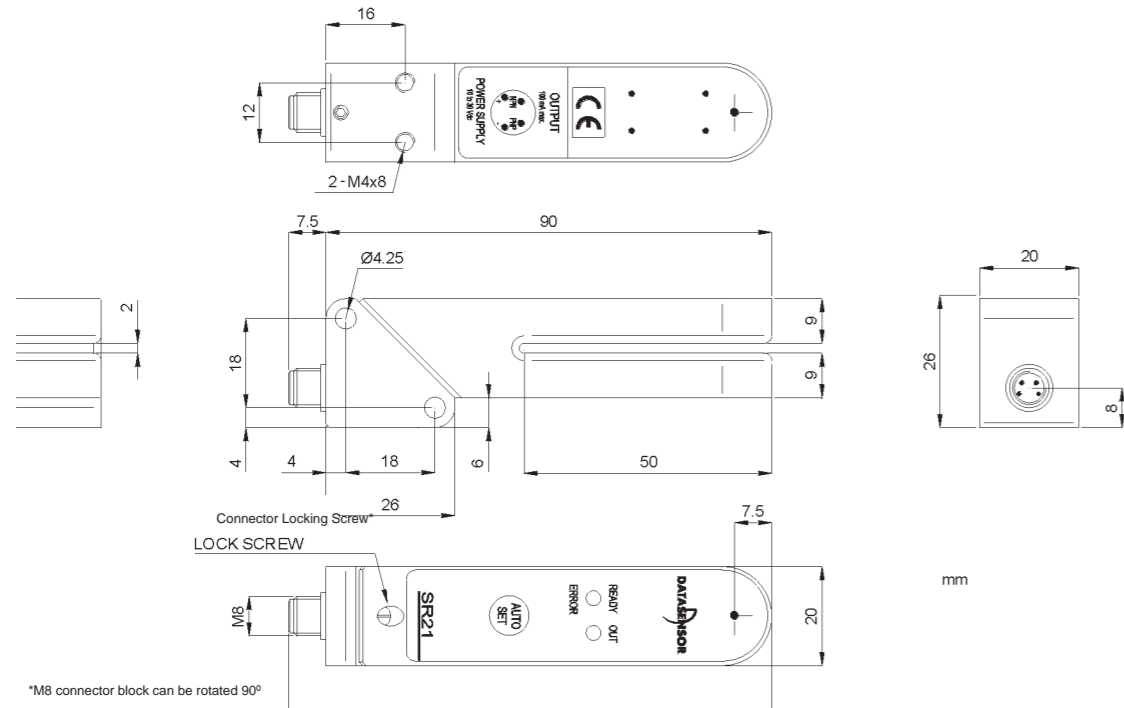

Indicators & Settings

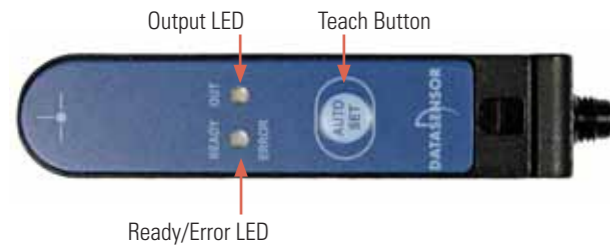

Connections

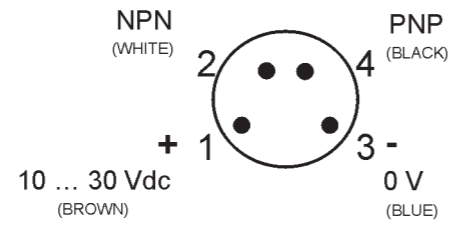

Specifications

		SR21-RG
Power Supply	10 - 30V DC, reverse polarity protection	√
Current Draw	55mA max.	√
Light Emission	Red 635nm/green LED 535nm	√
Resolution	0.5mm	√
Slot Width	2mm	√
Slot Depth	50mm	√
Detection Point Depth	7.5mm	√
Setting	AUTO SET push-button	√
Indicators	Yellow OUTPUT LED	√
	Green/red dual color READY/ERROR LED	√
Output Type	NPN and PNP	√
Saturation Voltage	2V max.	√
Output Current	100mA max., short-circuit protection	√
Response Time	20µs max.	√
Switching Frequency	25kHz	√
Operating Mode	Dark/light configurable	√
Connection	M8 4-pole connector	√
Electrical Protection	Class 1	√
Mechanical Protection	IP65	√
Housing Material	Aluminum	√
Lens Material	Glass	√
Weight	120g max.	√
Operating Temperature	-20 to +60°C	√
Storage Temperature	-20 to +70°C	√
Reference Standard	EN60947-5-2	√

 Additional models are available. Visit www.idec-ds.com for more information.

Part Number

Function	Emission	Frequency	Part Number
	red/green	25kHz	SR21-RG

For information on accessories, see page 229.

 Additional models are available. Visit www.idec-ds.com for more information.

Connector Cables (for connector model sensors)

Appearance	Type & Length	Use with	Part No.
	5m axial 4-pole M8 cable	SR21	CS-B1-02-G-05
	5m radial 4-pole M8 cable		CS-B2-02-G-05

Distance: S80**Laser Distance Sensor with Time-of-Flight Measurement**

- High precision and speed
- Measurement range adjustable to 7m
- 4-digit display and RS485 serial interface

The S80 series, in a compact sturdy metal housing, offers an innovative class 2 laser distance sensor with time-of-flight measurement. This technology, based on the measurement of the time between the emission and receipt of the laser light pulses, ensures accurate distance detection.

The sensors function from 0.3 to 7m, within an adjustable range, in positioning or detection applications, such as double-threshold background suppression over long distances.

All models have two outputs, available in both the NPN and PNP models, that can be set at different distances. While the measurement value is a 4-20mA analog output and RS485 serial interface; the latter can also be used to set all the sensor parameters.

In addition, the S80 series offers the option to adjust the 4-20mA analog output. This feature allows the minimum and maximum values of the operating distance to be set and linked to the minimum and maximum current.

A 4-digit display shows the distance, as well as the parameters that can be set using the three buttons.

Laser distance sensors with time-of-flight measurement are suitable for long distance measurements offering constant performance along the entire range. Resolution represents the minimum dimension, or the smallest target detected by the sensor.

Linearity indicates the maximum deviation of the analog output with respect to the ideal value and is expressed as a percentage of the full range.

Temperature drift indicates the maximum deviation in relation to variations in the sensor temperature and is expressed in mm/°C.

Finally, repeatability represents the variation of the measurement made different times on a target at the same distance.

Dimensions (mm)

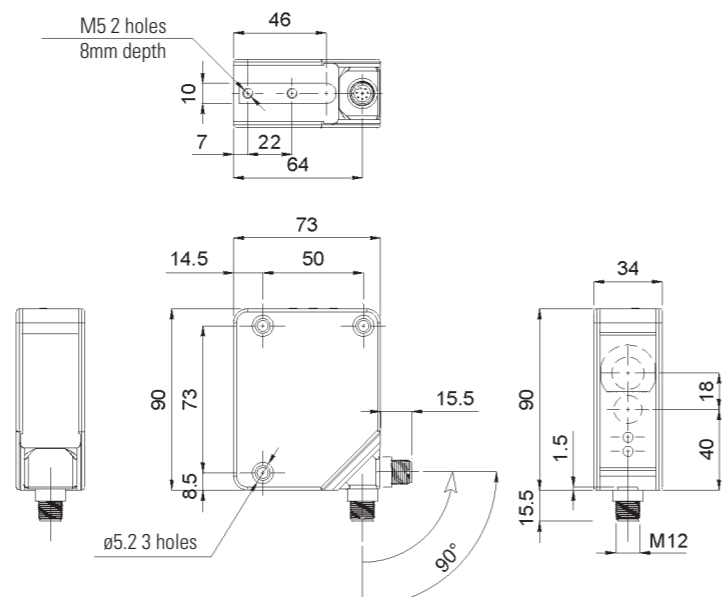

Indicators & Settings

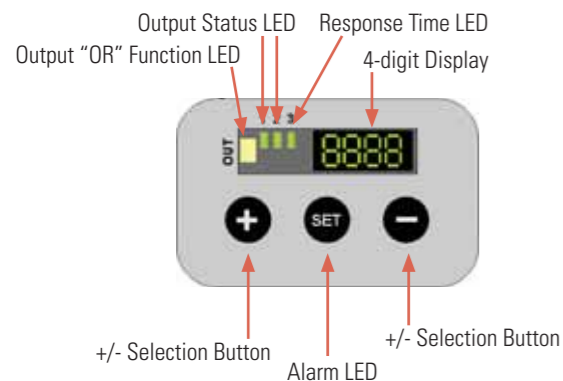

Connection

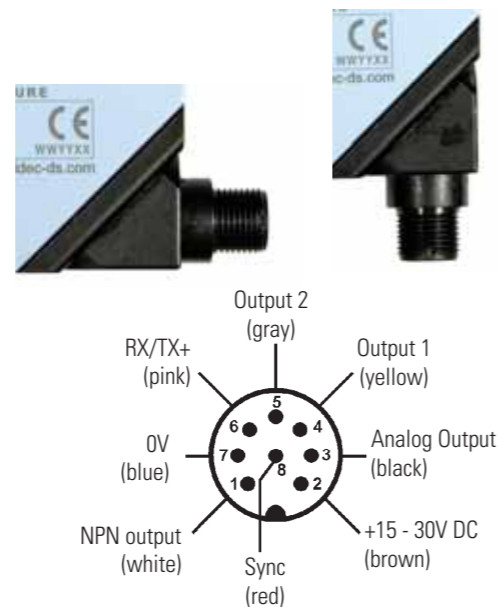

Specifications

		S80-MH-5-YL09-PPIZ	S80-MH-5-YL09-NNIZ
Direct Measurement Range ¹	0.3 - 7m scalable	√	√
Digital Resolution	0.4mm	√	√
Linearity	0.3%	√	√
Temperature Drift	±0.6mm/°C	√	√
Repeatability ²	3mm @ 4m	√	√
	7mm @ 7m	√	√
Switching Output Hysteresis ³	5mm	√	√
Power Supply	15 - 30 V DC (limit values)	√	√
Ripple	2Vpp max.	√	√
Current Draw	110mA max. @ 24V DC	√	√
Light Emission	Red Laser 665nm, class 2	√	√
Setting	SET push-button	√	√
	+/- push-button	√	√
Indicators (On Control Panel)	4-digit display	√	√
	Yellow OUTPUT LED	√	√
	Green OUTPUT STATUS LED	√	√
	Green FAST mode LED	√	√
Indicators (On Front)	Yellow OUTPUT LED	√	√
	Red ALARM LED	√	√
Output Type	2 PNP or 2 NPN	√	√
	4 - 20 mA analog	√	√
Output Current	≤ 100mA	√	√
Saturation Voltage	≤ 2V	√	√
Response Time	5ms (NORMAL)	√	√
	1ms (FAST)	√	√
Switching Frequency	100Hz (NORMAL)	√	√
	500Hz (FAST)	√	√
Timing Function	Selectable between 5, 10, 20, 30, 40ms	√	√
Auxiliary Functions	Synchronism (SYNC)	√	√
	Keylock ⁴	√	√
	RS485 serial interface	√	√
Connection	M12 8-pole connector	√	√
Electrical Protection	class 2	√	√
Mechanical Protection	IP67	√	√
Protection Devices	A, B ⁵	√	√
Housing Material	aluminium	√	√
Lens Material	Glass	√	√
Weight	330g max.	√	√
Operating Temperature	-10 to +50°C	√	√
Storage Temperature	-25 to +70°C	√	√
Reference Standard	EN60947-5-2, EN60825-1, UL508	√	√

1. On target 90% white
 2. In Normal mode with 5 ms response time
 3. Active with SYNC wire connected to + V DC for at least 1 s at powering
 4. Connector can be locked in two positions
 5. A - reverse polarity protection
 B - overload and short-circuit protection

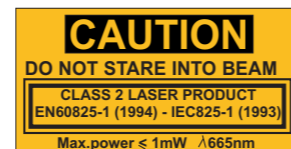

Detection Diagrams

Analog Output

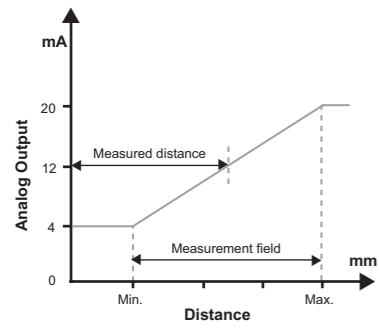

Digital Outputs

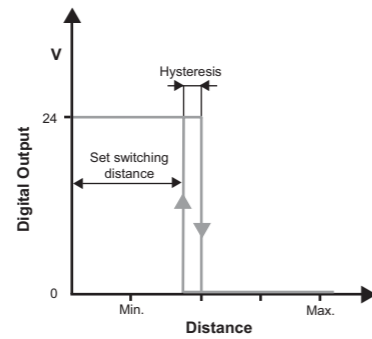

Direct Measurement Distance

(According to Object Reflection Degree)

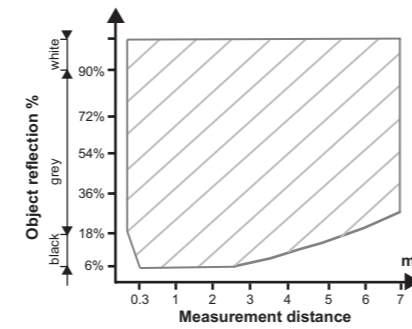

Part Numbers

Function	Max. Distance	Reflector	Connection	Output	Part Number
	7m	no	M12 connector	PNP	S80-MH-5-YL09-PPIZ
	7m	no	M12 connector	NPN	S80-MH-5-YL09-NNIZ

For information on accessories, see page 229.



Additional models are available. Visit www.idec-ds.com for more information.

Connector Cable (for connector model sensors)

Appearance	Type & Length	Use with	Part No.
	5m axial 8-pole M12 cable	S65, S80	CS-A1-06-B-05

Distance: SA1D

Analog Distance Detection Sensors



- Triangulation ensures high-precision when sensing the presence or position of objects
- Wide sensing range: 7.87" to 19.69" (200 to 500mm)
- Select analog output (20 to 4mA) for continuous values; use digital output (on/off); or use both together
- Far and near limits can be defined for detecting objects within a specified zone
- A ten-dot LED level meter provides a dynamic display of detected positions and also shows near and far settings
- Alarm output indicates when sensing conditions may result in inaccurate results

SA1D sensor provides versatile, accurate distance sensing for your specific application needs. Both in analog and digital output style for comparison.

The advantage of the SA1D is that the shape, size, material, and color do not detract from accurate measurement.

Dimensions (mm)

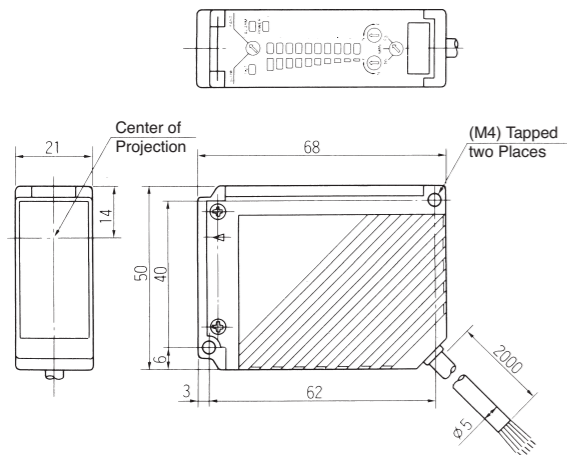

Wiring

Wire Color	Name	Function
Brown	+V	12 to 24V DC, 100mA (maximum)
Black	OUT	Digital Output, 30V DC, 100mA
Orange	ALM	Alarm Output, 30V DC, 100mA
Blue	GND	Power Ground (0 V)
White	ANALOG	Analog Output, 20 to 4mA
Shield	GND	Shield

An analog output line may be extended up to 33' (10m), as long as the cable used is equal to or superior to the cable provided. Other lines may be extended up to 164' (50m), using #22 AWG (0.3mm²) wire.

Specifications

		SA1D-LK4	SA1D-LL4	
General Specifications	Power Voltage	12 to 24V DC ± 10% (ripple 10% maximum)	√	√
	Current Draw	100mA (maximum)	√	√
	Dielectric Strength	Not specified due to capacitor grounding	√	√
	Insulation Resistance	Not specified due to capacitor grounding	√	√
	Operating Temperature	0° to +55°C (performance will be adversely affected if the sensor becomes coated with ice)	√	√
	Operating Humidity	35 to 85% RH (avoid condensation)	√	√
	Storage Temperature	−20° to +70°C	√	√
	Vibration Resistance	Damage limits: 10 to 55Hz, amplitude 1.5mm p-p, 2 hours in each of 3 axes (power off)	√	√
	Shock Resistance	Damage limits: 500m/sec ² (approximately 50G), 5 shocks in each of 3 axes	√	√
	Extraneous Light Immunity	Sunlight: 10,000 lux; Incandescent light: 3,000 lux (maximum) — defined as the incident or unwanted light received by a sensor, unrelated to the presence or absence of the intended object	√	√
	Material	Housing: Diecast zinc; Filter and lens: Acrylic	√	√
	Degree of Protection	IP65	√	√
	Cable	Cable type: 5-core cabtyre cable 0.2mm ² , 6'–6-3/4" (2m) long	√	√
	Weight	Approximately 350g	√	√
Dimensions	2.68"H x 0.83"W x 1.97"D (68mm H x 21mm W x 50mm D)	√	√	
Function Specifications	Analog Output	20 to 4mA, 5V (maximum), fixed range	√	√
	Digital Output	NPN or PNP transistor open collector, 30V DC, 100mA (maximum), Residual: 1V (NPN), 2V (PNP)	√	√
	Alarm Output	NPN or PNP transistor open collector, 30V DC, 100mA (maximum), Residual: 1V (NPN), 2V (PNP)	√	√
	Level Meter (10-dot LED display)	Analog: Represents object distance corresponding to analog output on a 10-dot LED display Digital: Indicates near or far limit settings	√	√
	Out LED	On: When digital output is on	√	√
	Power LED	On: When power is on	√	√
	Alarm LED	On: When reflected light is excessive or insufficient	√	√
	Digital Output	Digital output and OUT LED turns on when object is within near and far limits	√	√
	Digital Output Setting	14-turn control for far/near setting (far and near limits can be set separately)	√	√
	Response Time	High-speed (F): 5ms (maximum) Normal speed (S): 50ms (maximum)	√	√
	Repeat Error	High-speed: 4% (maximum) Normal speed: 2% (maximum)	√	√
	Hysteresis	10% (maximum), defined as the difference between the operating point and the release point	√	√
	Light Source Element	Infrared LED (modulation mode)	√	√
	Wavelength	880nm (infrared LED)	√	√
	Receiver Element	Position sensitive device (PSD)	√	√
Detectable Object	Opaque	√	√	

Part Numbers

Function	Sensing Range	Reference Object	Output	Part Number
	200 to 500mm (7.87" to 19.69")	White: 75 x 75mm (2.95" x 2.95")	NPN	SA1D-LK4
	200 to 500mm (7.87" to 19.69")		PNP	SA1D-LL4

For information on accessories, see page 229.

Applications

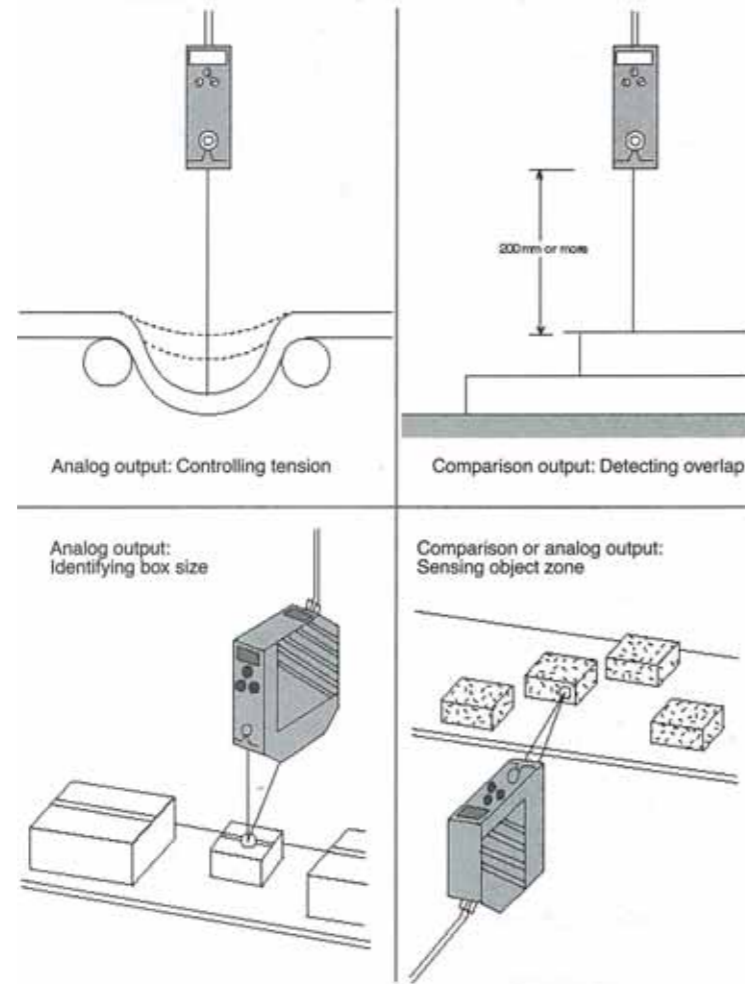

Distance: MX1C
Self-Contained Laser Displacement Sensors



- Analog output (20 to 4mA) can be selected for continuous values; digital output (on/off) can be used; or both can be used together
- Miniature sensor head is compact for high-density installations
- Visible beam is easy to align with target
- Adjustable response speed
- Shape, size, color and material do not detract from accurate measurement (see note)
- Wide sensing range: 2.36" to 6.30" (60mm to 160mm)
- A ten-dot dynamic display shows detected positions
- Alarm output indicates when sensing conditions may result in inaccurate results

The MX1C is a self contained laser displacement sensor. Featuring a small size and high resolution of 50 microns (0.002"), the MX1C is perfect for small mounting areas with delicate applications. The MX1C is easy to align with its visible Red laser. The MX1C offers a 4-20mA analog output, and, a discrete transistor output for displacement determination.

The MX1C utilizes triangulation to determine object displacement. The sensor head projects a laser beam to the object. The diffuse-reflected light from the object's surface is received as a spot image. This spot image moves from position A to B on the PSD (position sensitive device). Optical triangle is used to compute the exact distance between the sensor and the object.



1. Laser sensing of mirror-like surfaces is not recommended. For best results detecting reflective surfaces, tilt the sensor to reduce direct laser reflection. Sensing at a small angle (approximately $\pm 10^\circ$) does not significantly reduce sensing accuracy or linearity of resulting analog output.
2. **WARNING:** Class IIIa laser. Do not allow the laser to shine directly into the eyes. Always consider eye safety when installing a laser sensor. Make sure that the laser beam cannot inadvertently shine into the eyes of people passing by or working in the vicinity. See laser safety information on page 232.

Dimensions (mm)

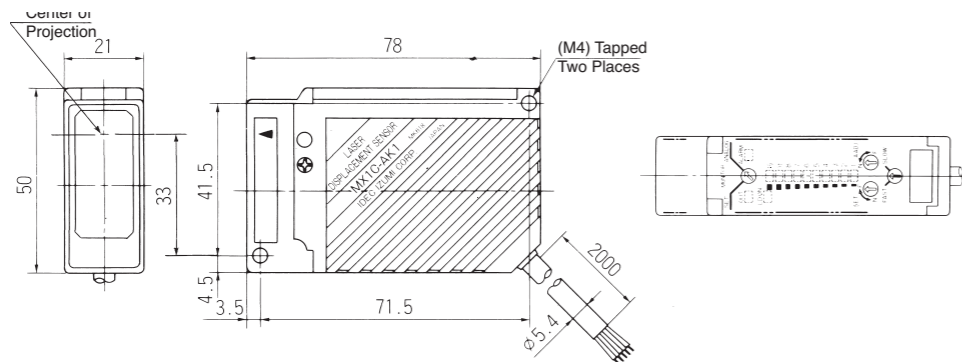

Specifications

		MX1C-AK1	MX1C-AL1	
General Specifications	Power Voltage	24V DC (ripple 10% maximum)	√	√
	Current Draw	200mA (maximum)	√	√
	Dielectric Strength	Between live and dead parts: 500V AC, 1 minute	√	√
	Insulation Resistance	Between live and dead parts: 100MΩ (minimum), with 500V DC megger	√	√
	Operating Temperature	0 to +45°C (performance will be adversely affected if the sensor becomes coated with ice)	√	√
	Storage Temperature	-20°C to +70°C	√	√
	Operating Humidity	35% to 85% RH (avoid condensation)	√	√
	Vibration Resistance	Damage limits: 10 to 55Hz, amplitude 1.5mm p-p, 2 hours in each of 3 axes (when de-energized)	√	√
	Shock Resistance	Damage limits: 100m/sec ² (approximately 10G), 5 shocks in each of 3 axes	√	√
	Extraneous Light Immunity	Incandescent light: 3,000 lux (maximum) — defined as incident or unwanted light received by a sensor, unrelated to the presence or absence of intended object	√	√
	Material	Housing: diecast zinc; Filter: glass; Lens: acrylic; Rear cover: polycarbonate	√	√
	Degree of Protection	IP65 — IEC Pub 529; Sensors rated IP65 are dust-tight, water-resistant, and perform best when not subjected to heavy particle or water blasts	√	√
	Cable	Cable type: 6-core catbyre cable 0.3mm ² , 6' 6 3/4" (2m) long	√	√
	Weight	Approximately 400g	√	√
Dimensions	1.97"D x 0.83"W x 3.07"D (50mm H x 21mm W x 78mm D)	√	√	
Function Specifications	Resolution	0.002" (50 μm)—measuring conditions: sensing a white ceramic object at the reference sensing distance (60mm) using the normal response speed (50ms) at 25°C	√	√
	Analog Output	20 to 4mA, 5V (maximum), fixed range	√	√
	Digital Output	NPN or PNP transistor open collector: 30V DC, 100mA (maximum); Residual: 1V (NPN), 2V (PNP)	√	√
	Alarm Output	NPN or PNP transistor open collector: 30V DC, 100mA (maximum); Residual: 1V (NPN), 2V (PNP)	√	√
	Level Meter (ten-dot LED)	Analog: Represents analog output level according to the object distance Digital: Indicates preset position for near limit	√	√
	Out LED	On: When digital output on	√	√
	Laser Diode LED	On: While laser is emitted (LD ON), laser emits approximately 1 second after power-up	√	√
	Alarm LED	On: When reflected light is insufficient	√	√
	Digital Output	On: When object is within the near limit setting and beyond the close end of the sensing range (≥ 2.36" or 60mm from the sensor)	√	√
	Digital Output Setting	Fine-tuning dial for near limit setting	√	√
	Response Time	High-speed (F): 5ms (maximum); Normal speed (S): 50ms (maximum)	√	√
	Detectable Object	Non-mirror-like surfaces	√	√
	Analog Adjustment	0.20" (5mm) = 0.8mA using multi-turn dial	√	√
	Linearity	±100 μm ±1% of displacement value, defined as how linear (i.e. accurate) the actual analog output is, with respect to distance	√	√
	Hysteresis	0.039" (1mm), defined as the difference between the operating point and the release point	√	√
Temperature Drift	5 μA per °C with 1.97" (50mm) square white ceramic	√	√	
Light Source Element	Visible laser diode (670nm), 5 mW laser	√	√	
Receiver Element	PSD (position sensitive device)	√	√	

Part Numbers

Function	Output	Sensing Range	Resolution	Part Numbers
	NPN	60 to 160mm (2.36" to 6.30")	0.002" (50µm)	MX1C-AK1
	PNP			MX1C-AL1

Applications

Checking for warped boards

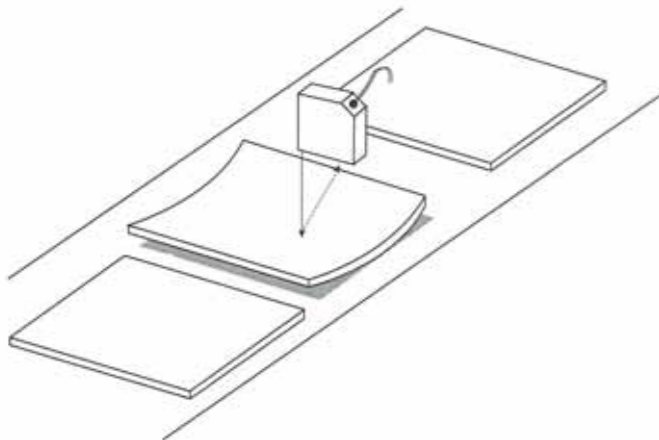

Sensing loose caps

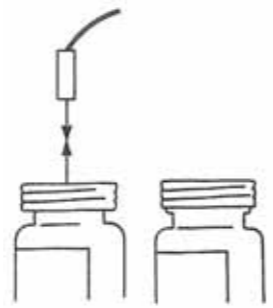

Detecting the height and width of wood or blocks

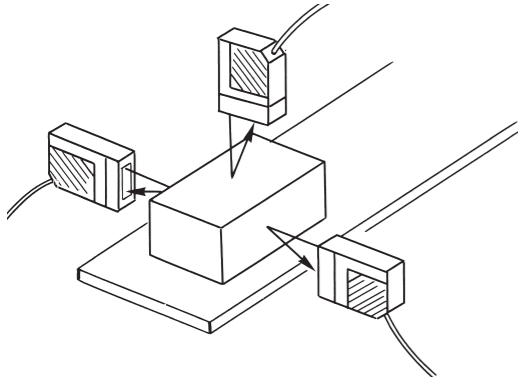

Positioning of a robot or actuator

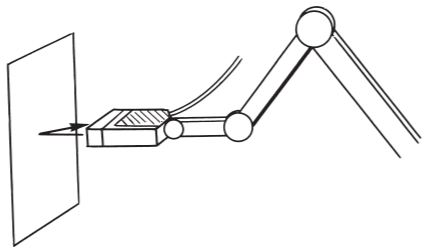

Detecting the thickness of lumber

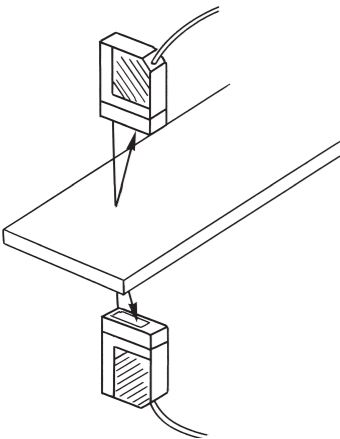

Detecting overlapping sheets/ Counting sheets of paper

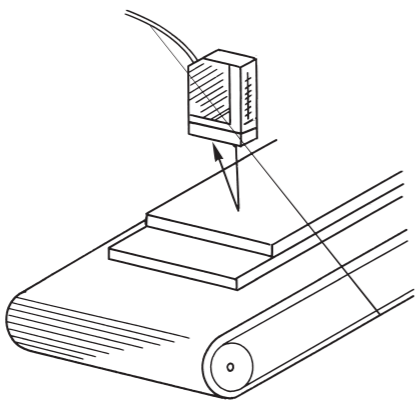

Sensing the roundness of a roller

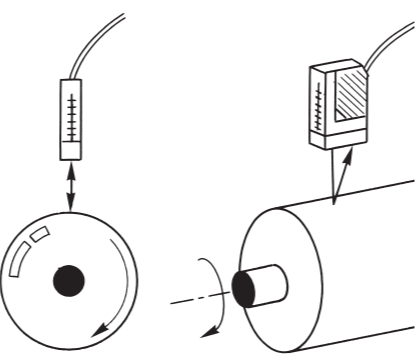

Installation

See page 233 for general sensor instructions. Below are considerations specific to the MX1C miniature laser sensors.

When installing multiple sensors, provide the recommended clearance as shown below, to prevent the interference of signals.

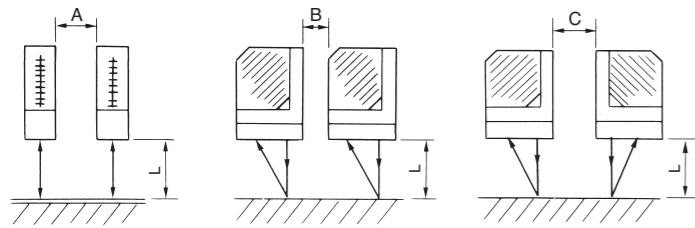

L	A	B	C
2.36" (60mm)	0	0	0
4.33" (110mm)	0	0.79" (20mm)	1.97" (50mm)
6.30" (160mm)	0.79" (20mm)	2.36" (60mm)	3.94" (100mm)

Laser sensing of mirror-like surfaces is not recommended, as the sensor receiver is designed for detecting diffuse-reflected light. Direct laser reflection may result in unreliable results.

For best results detecting reflective surfaces, tilt the sensor to reduce direct laser reflection. Sensing at a small angle (approximately $\pm 10^\circ$) does not significantly reduce the sensing accuracy or linearity of the resulting analog output.

WARNING: Class IIIa laser. Do not allow the laser to shine directly into the eyes. Always consider eye safety when installing a laser sensor. Make sure laser beam cannot inadvertently shine into the eyes of people passing by or working in the vicinity. See laser safety information on page 232.

Projected Beam Characteristics

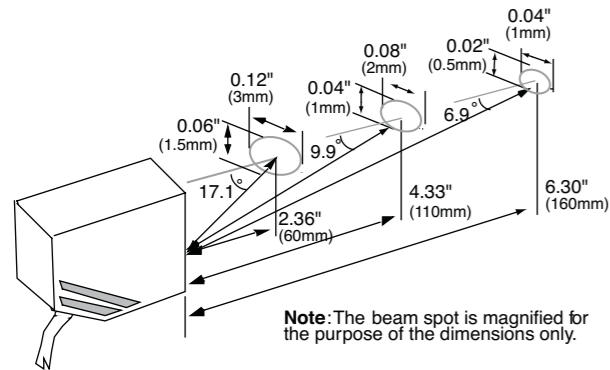

Due to the focusing characteristics of the lens, the projected beam of a laser sensor gets smaller (converges) from the near end to the far end of the sensing range. The beam gets larger (diverges) beyond the far end of the sensing range.

Wiring

Wire Color	Name	Function
Brown	+V	24V DC, 200mA (maximum)
Black	OUT	Digital Output, 30V DC, 100mA
Orange	ALM	Alarm Output, 30V DC, 100mA
Blue	GND	Power Ground (0 V)
White	ANALOG	Analog Output, 20 to 4mA
Peach	LD RMT	Remote Interlock On/Off Switch
Shield	A. GND	Analog Ground

The analog output line may be extended up to 33' (10m), as long as the cable used is equal to or superior to the cable provided. Other lines may be extended up to 164' (50m), using #22 AWG (0.3mm²) wire.

Schematics

NPN (MX1C-AK1)

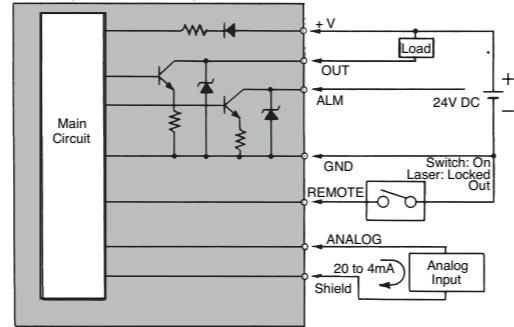

PNP (MX1C-AL1)

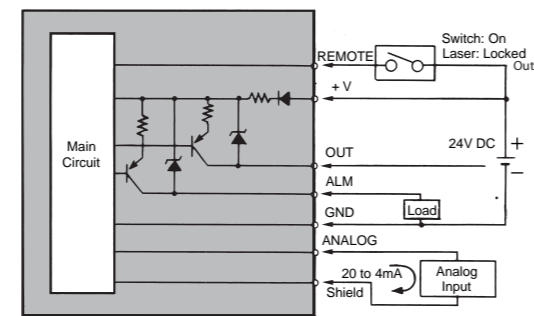

Area: AS1

High-resolution Photoelectric Light Grids

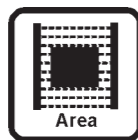

- Area sensors with crossed beams
- 100mm height
- Operating distance 2.1m
- 0.2mm minimum detectable object thickness
- PNP output and Scan mode input

The photoelectric light grids of the AS1 series are crossed-beam area sensors able to detect all objects, as small as a 0.2mm thickness, inside a 100mm height, over operating distances reaching 2.1m between emitter and receiver.

AS1 area sensors are an ideal solution for detection of very small objects, even when moving and in varying positions inside a controlled height and width. The distance between emitter and receiver can range from 0.3 to 2.1m.

With their short response time, ultra-compact AS1 light grids are perfect for fast conveyor lines, such as insertion and downloading lines, and for detection and counting of objects in random positions.

The PNP output is activated every time an object is detected between the receiver and emitter.

The AS1 has a high resolution with a light array that has 16 beams to ensure accurate detection.

Selection inputs of the SCAN MODE can configure 4 different crossed-beam scanning modes. These different modes allow variances in detection performance, in particular, resolution can be increased to 0.2mm thickness, or response time to less than 3ms.



Dimensions (mm)

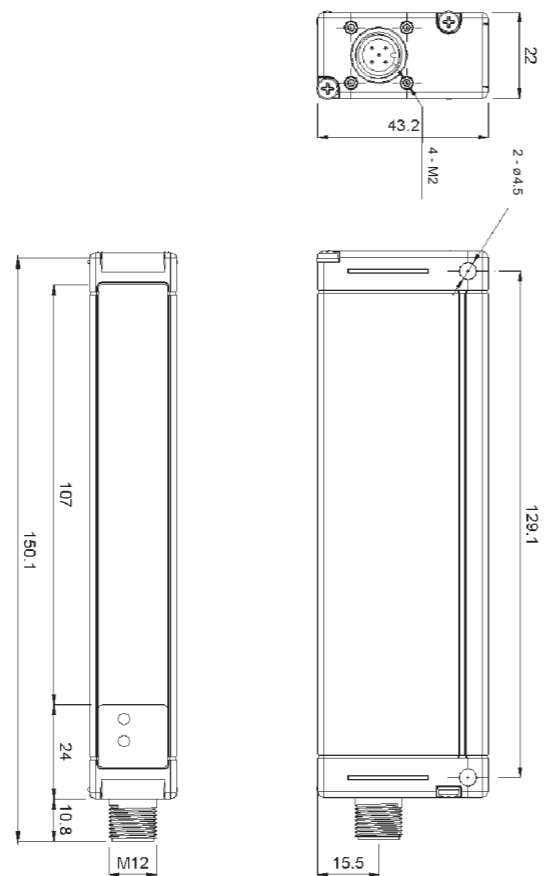

Receiver (RX)

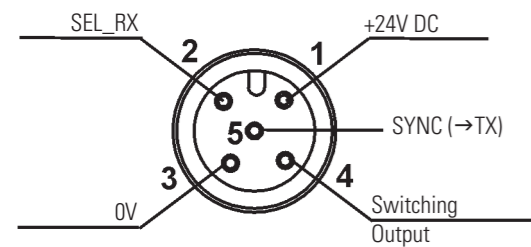

- 1 = brown = +24 V DC
- 2 = white = SEL_RX
- 3 = blue = 0V
- 4 = black = Switching Output
- 5 = gray = SYNC

Connections

Emitter (TX)

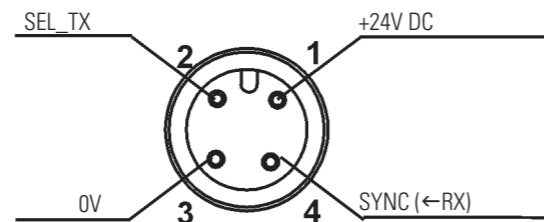

- 1 = brown = +24V DC
- 2 = white = SEL_TX
- 3 = blue = 0V
- 4 = black = SYNC

Specifications

		AS1-LD-HR-010-J
Power Supply	24V DC ± 15%	√
Current Draw - Emitting Unit	150mA max.	√
Current Draw - Receiving Unit	40mA max. load excluded	√
Outputs	1 PNP output	√
Load Current Output	100mA; short-circuit protection	√
Saturation Voltage Output	≤ 1.5V at T=25°C	√
Emission Type	Infrared LED 880nm	√
Response Time	2.75 - 8ms	√
Number of Optics	16	√
Resolution	Refer to tables	√
Operating Distance	0.3 — 2.1m	√
Receiver Indicators	Green POWER ON LED	√
	Yellow OUT LED	√
Emitter Indicators	Green POWER ON LED	√
Operating Temperature	0 to + 50°C	√
Storage Temperature	- 25 to + 70°C	√
Humidity	15 - 95%	√
Mechanical Protection	IP65	√
Housing Material	Aluminium	√
Optics Material	PMMA	√
Connections	M12 4-pole connector (TX)	√
	M12 5-pole connector (RX)	√
Weight	300g	√



Operating Distance

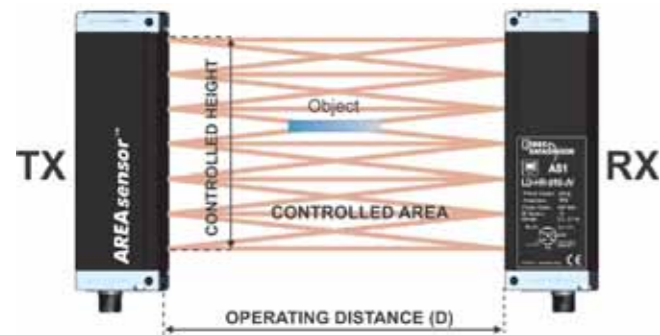

High-resolution Scanning Mode

Prog. N°	SEL_RX	SEL_TX	Resolution	Response Time (msec)
1	0V DC or FLOAT	0V DC or FLOAT	LOW	2.75
2	0V DC or FLOAT	24V DC	M/L	3
3	24V DC	0V DC or FLOAT	M/H	7.75
4	24V DC	24V DC	HIGH	8

Scan Mode 1

High-speed / Low-resolution
 Minimum Object Detection
 Flat = 0.4 (thickness) x 100 (width) mm
 Cylindrical Objects = ø6mm

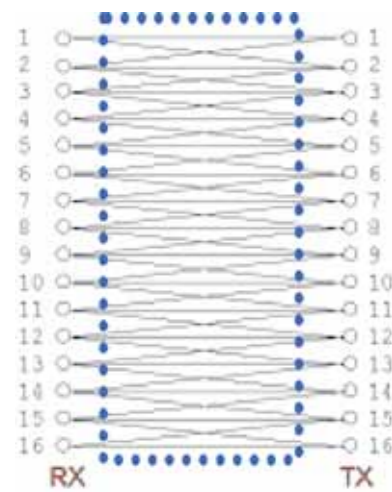

Scan Mode 2

High-speed / Mid-resol. Central Area
 Minimum Object Detection
 Flat = 0.4 (thickness) x 90 (width) mm
 Cylindrical Objects = ø6mm

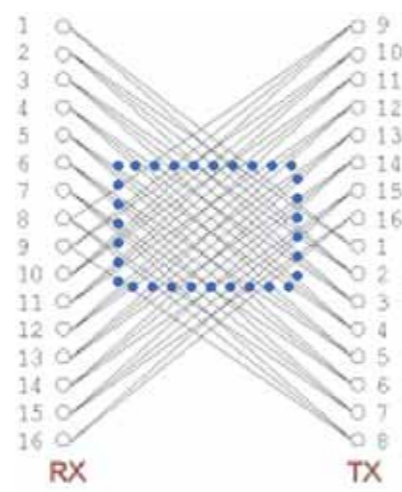

Scan Mode 3-4

Low-speed / High-resolution
 Minimum Object Detection
 Flat = 0.2 (thickness) x 75 (width) mm
 Cylindrical Objects = ø6mm

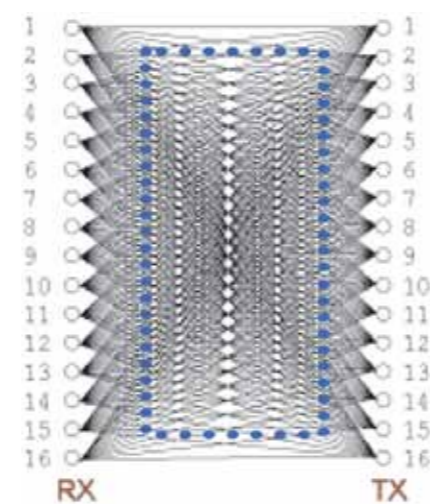



Part Number

Function	Distance	Resolution	Height	Part Number
 Area	0.3 — 2.1 m	High	100 mm	AS1-LD-HR-010-J

For information on accessories, see page 229.

 Additional models are available. Visit www.idec-ds.com for more information.

Connector Cables (for connector model sensors)

Appearance	Type & Length	Use with	Part No.
	5m axial 4-pole M12 cable	S51, S60, S62, DS1 (emitter) AS1 (emitter)	CS-A1-02-G-05
	5m radial 4-pole M12 cable		CS-A2-02-G-05
	5m axial 5-pole M12 cable	TL46, LD46, DS1 (receiver), AS1 (receiver)	CS-A1-03-G-05

Area: DS1

Detection & Measurement Light Grids with Analog Output



- Position and dimension measurement
- 5mm resolution and 1ms response time
- 100 to 300mm height
- Operating distance up to 2.1m
- PNP digital and 0-10V analog outputs

The DS1 AREAscan™ sensor is a compact multibeam light grid suitable for detection and measurement of objects with different shapes and sizes. DS1 is available with 100mm height, 5mm resolution and an operating distance of 2.1m.

The electronics are fully integrated and as a result, no external drivers are required. A value is supplied through the analog 0-10V output that is proportional to the number of interrupted beams.

The PNP digital output is activated every time a beam between emitter and receiver is interrupted. The response time, less than 3ms, depending on the height and measurement resolution, allows installation on the fastest machines and processes.

The measurement of the object's position or dimensions, placed inside the sensitive area, is obtained by the 0 - 10V analog output, which supplies a signal proportional to the number of interrupted beams.

The PNP digital output is activated each time the beam is interrupted by an object; in this case, the yellow OUT LED on the receiving unit panel turns on.

A green POWER ON LED, also on this panel, signals the wrong alignment between the emitting and receiving units, as well as when an object moves outside or near the maximum operating distance.



Dimensions (mm)

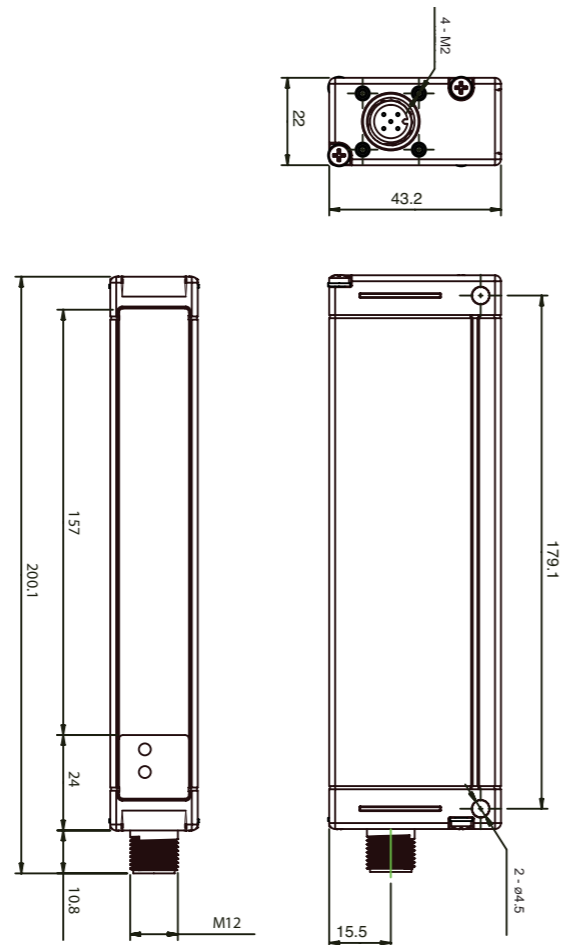

Receiver (RX)

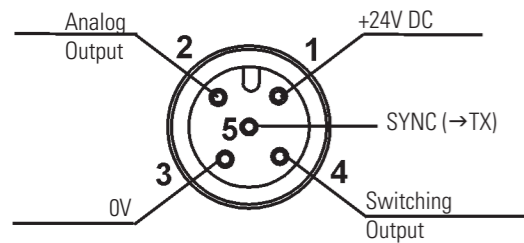

- 1 = brown = +24 V DC
- 2 = white = Analog Output
- 3 = blue = 0V
- 4 = black = Switching Output
- 5 = gray = SYNC

Connections

Emitter (TX)

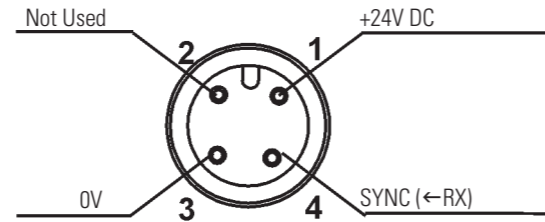

- 1 = brown = +24V DC
- 2 = white = Not Used
- 3 = blue = 0V
- 4 = black = SYNC

Specifications

		DS1-LD-HR-015-JV
Power Supply	24V DC ± 15%	✓
Current Draw - Emitter Unit	150mA max.	✓
Current Draw - Receiver Unit	50mA max. without load	✓
Outputs	PNP	✓
	Analog output 0 - 10V	✓
Load Current On PNP Output	100mA; short circuit protection	✓
Saturation Voltage On PNP Output	≤1.5 V at T=25°C	✓
Response Time	1ms - 2.75ms	✓
Emission Type	Infrared LED 880nm	✓
Resolution	5 - 7mm	✓
Measurement Precision	± 3.5 - 7mm	✓
Operating Distance	0.15 - 2.1m	✓
Receiver Indicators	Green POWER ON LED	✓
	Yellow OUT LED	✓
Emitter Indicators	Green POWER ON LED	✓
Operating Temperature	0 to + 55°C	✓
Storage Temperature	- 25 to + 70°C	✓
Humidity	15 - 95%	✓
Mechanical Protection	IP65	✓
Housing Material	Aluminium	✓
Optics Material	PMMA	✓
Connections	M12 4-pole connector for TX	✓
	M12 5-pole connector for RX	✓
Weight:	340g	✓



Detection Diagrams

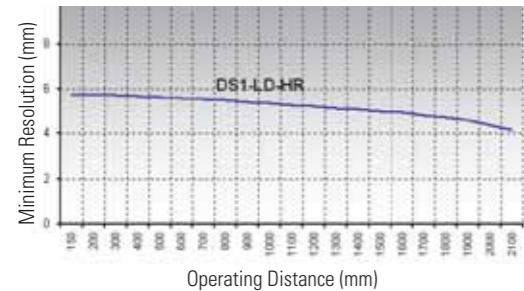



Variation of the minimum resolution, according to the operating distance between the emitting and receiving units.

Part Numbers

Function	Resolution	Height	Part Number
	high	150mm	DS1-LD-HR-015-JV

Additional models are available. Visit www.idec-ds.com for more information.

Connector Cables (for connector model sensors)

Appearance	Type & Length	Use with	Part No.
	5m axial 4-pole M12 cable	S51, S60, S62, DS1 (emitter) AS1 (emitter)	CS-A1-02-G-05
	5m radial 4-pole M12 cable		CS-A2-02-G-05
	5m axial 5-pole M12 cable	TL46, LD46, DS1 (receiver), AS1 (receiver)	CS-A1-03-G-05

For information on accessories, see page 229.

Magnetic: DPRI

Magnetic Proximity Switches



- Lightweight, compact design reduces mounting space requirements
- Compact size allows units to be mounted in close proximity to each other
- Sealed reed contact can be used in dusty locations
- Long life and high reliability

The DPRI magnetic proximity switch incorporates a sealed reed switch and four magnets inside a compact housing. This self-contained proximity switch requires no external power supply and can detect the presence of magnetic objects without contact.

Dimensions

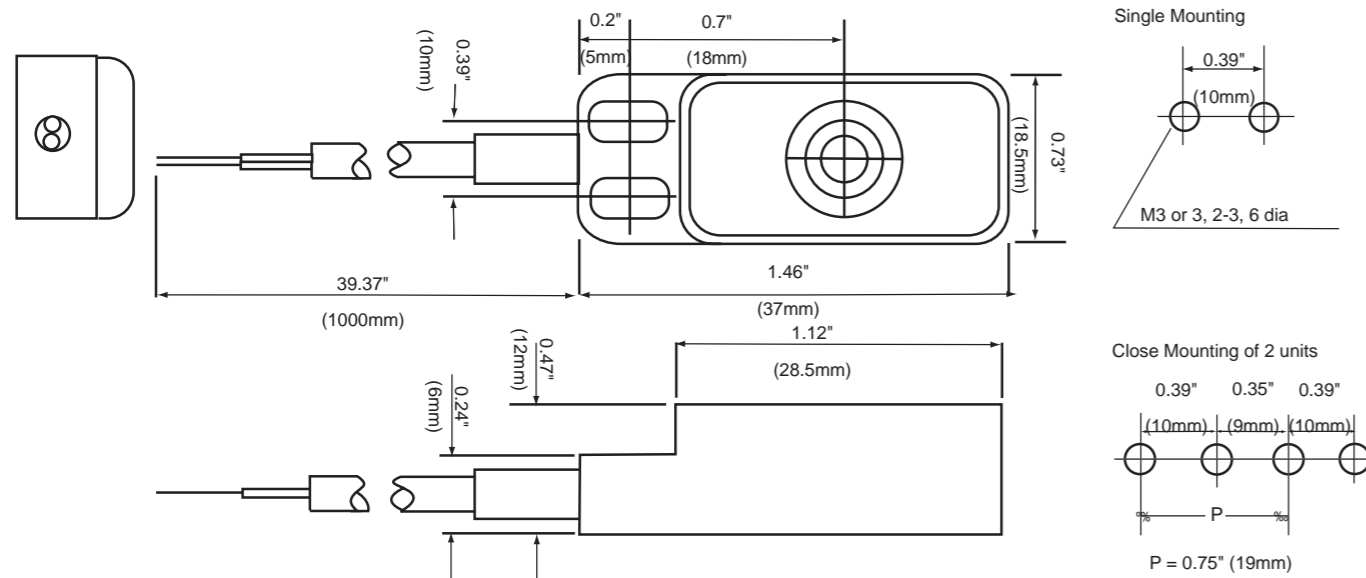

Specifications

		DPRI-01
Normal Switching Distance	5mm ±10%	√
Operating Distance	0 to 4mm	√
Release Distance	Over switching distance, 9mm (maximum)	√
Repeat Error ON	0.05mm (maximum)	√
Repeat Error OFF	0.15mm (maximum)	√
Temperature Error (−10 to 50°C)	±0.5mm or less (20°C as standard)	√
Response Speed	300Hz or less (bounce 0.4ms or less)	√
Output	Contact Configuration	1NO
	Switching Capacity	AC: 10VA (maximum) DC: 10W (maximum)
	Operating Voltage	AC: 100V (maximum) DC: 100V (maximum)
	Operating Current	AC: 0.25A (maximum) DC: 0.25A (maximum)
	Initial Contact Resistance	0.35Ω (maximum)
Shock Resistance	20G or less	√
Ambient Temperature Range	−10 to +50°C	√
Sensing Object	Magnetic materials: Fe, Ni, Cu, Ferrite, etc.	√
Standard Sensing Object	30 x 20 x 1mm, Ferromagnetic soft iron plate	√
Life Expectancy	Electrical	20,000,000 operations
	Mechanical	1,000,000,000 operations
Lead Wire	Cable type: 5mm 2-core vinyl cabtyre cable, 3-1/3' (1m) long	√
Weight	Approximately 40g	√

Part Number

Description	Part Number
Magnetic Proximity Switch	DPRI-01

For information on accessories, see page 229.



Operation Principle

The DPRI magnetic proximity switch incorporates a sealed reed switch and four magnets inside a compact housing. This self-contained proximity switch requires no external power supply and can detect the presence of magnetic objects without contact.

Application Sensors

Accessories

Brackets

Appearance	Item	Use with	Part Number
	Mounting bracket	S60, S62, S65	95ACC5330 (model ST-5020)
	Mounting bracket		95ACC5340 (model ST-5021)
	L shaped mounting bracket	S80	95ACC2260 (model ST-5037)

Diffuse-Reflected Light Fiber Optic Unit

Inspection Spot	Sensing Range	Use With	Part Numbers
ø 2.5 mm	10mm	SA1J, SA1J-F	SA9F-DA11
ø 5 mm	20mm		SA9F-DA12
ø 8 mm	30mm		SA9F-DA13







Lens Attachments

Description	Use With	Sensing Range	Part Number
For long range detection of opaque objects	SA9F-TS21	300mm	SA9Z-F11
	SA9F-TC21	200mm	
	SA9F-TM21	150mm	
Sideview attachment	SA9F-TS21	25mm	SA9Z-F12
	SA9F-TC21	20mm	
	SA9F-TM21	20mm	

Miscellaneous Accessories

Description	Use with		Part Number
Fiber cutter	All fiber units except heat resistant	HxLxD: 0.91" x 1.77" x 0.31" (23x 45 x 8Dmm) Included with fiber units; order replacement only	SA9Z-F01

Connector Cables (for connector model sensors)

Appearance	Type & Length	Use with	Part No.
	5m axial 4-pole M12 cable	S51, S60, S62, DS1 (emitter) AS1 (emitter)	CS-A1-02-G-05
	5m radial 4-pole M12 cable		CS-A2-02-G-05
	5m axial 8-pole M12 cable	S65, S80	CS-A1-06-B-05
	5m axial 5-pole M12 cable	TL46, LD46, DS1 (receiver), AS1 (receiver)	CS-A1-03-G-05
	5m axial 4-pole M8 cable	SR21	CS-B1-02-G-05
	5m radial 4-pole M8 cable		CS-B2-02-G-05

Lenses

Appearance	Item	Use with	Part Number
	Plastic lens with 9mm focus	TL46	95ACC2540
	Plastic lens with 18mm focus		95ACC1030
	Plastic lens with 22mm focus		95ACC1000
	Plastic lens with 28mm focus		890000194
	Plastic lens with 40mm focus	TL46, LD46	95ACC1220

Dimensions (mm)

95ACC5330 (model ST-5020)

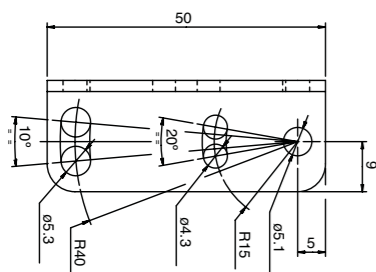
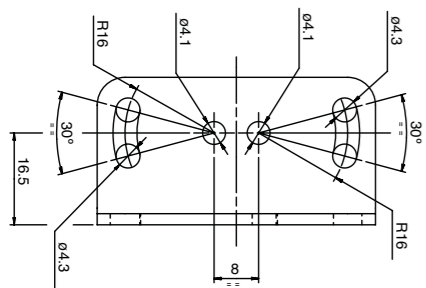

95ACC5340 (model ST-5021)

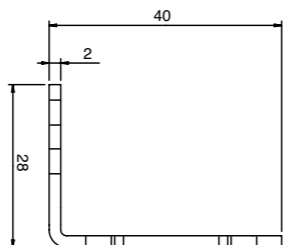
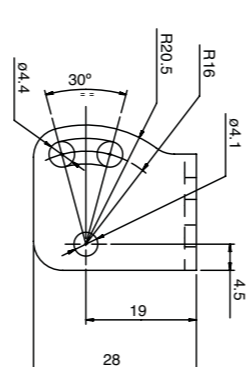
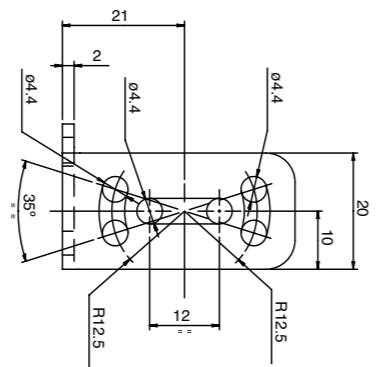
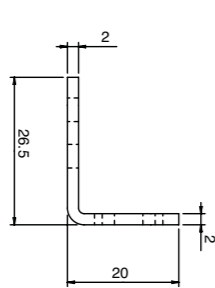

95ACC2260 (model ST-5037)

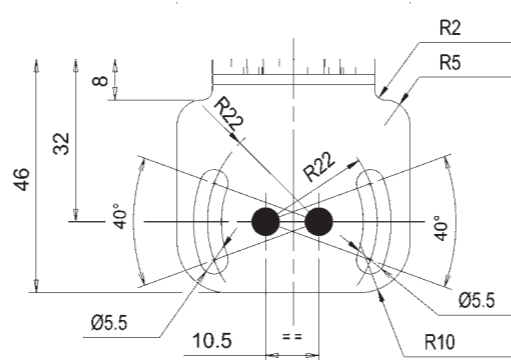
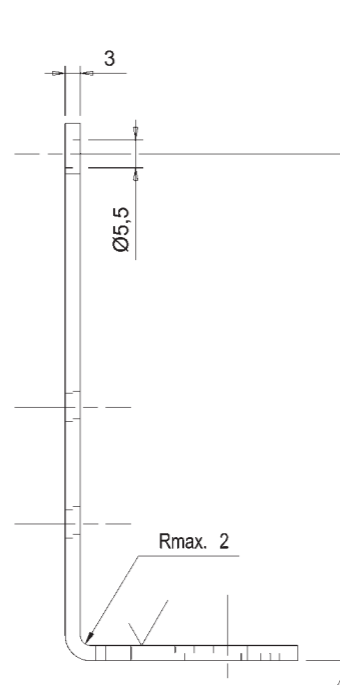
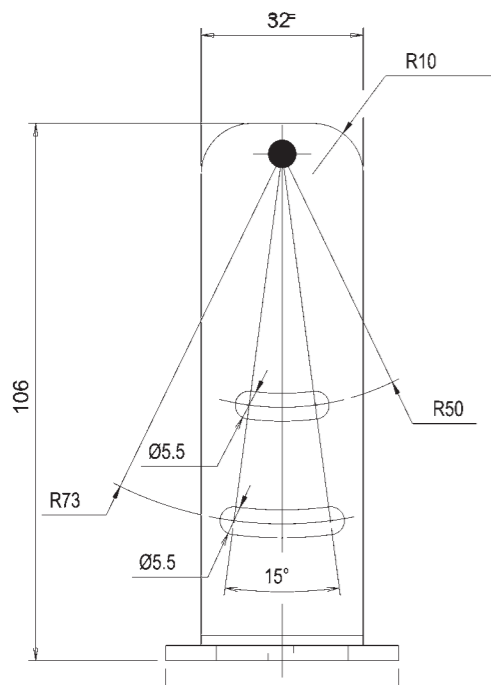

Dimensions (mm)

95ACC2540 (model No. 9 PMMA)

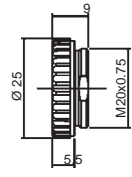

95ACC1030 (model No. 18 glass)

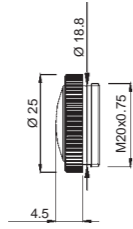

95ACC1000 (model No. 22 glass)

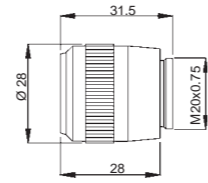

890000194 (model No. 28 glass)

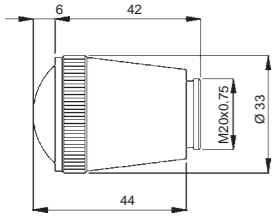

95ACC1220 (model No. 40 glass)

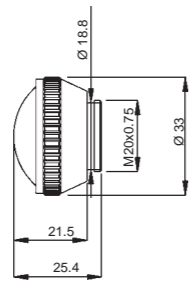

SA9Z-F01

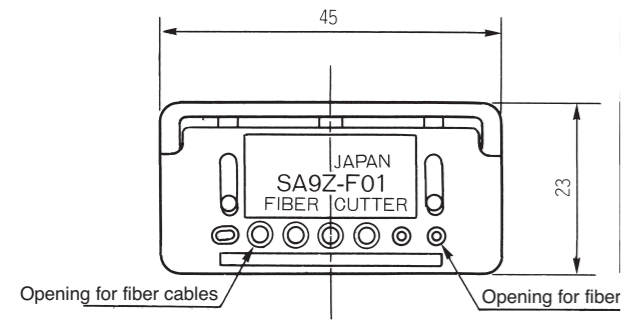

Laser Safety Information

Installation: If a sensor is installed so that the laser beam may shine or reflect into the eyes of a person passing by or working in the vicinity, place an opaque sheet of material in front of the beam to prevent potential eye injury. For people working near a laser sensor, protective glasses which screen out a significant amount of the harmful radiation are recommended at all times.

All laser sensors also include a remote interlock terminal which can be used to turn the laser on or off with an external switch, as required, to operate the sensor safely from a remote location.

To avoid exposure to harmful radiation, never disassemble a laser sensor.

WARNING: Do not allow class IIIa and IIIb laser beams to shine directly into the eyes. Do not allow lasers to reflect from a glossy, shiny, or reflective surface into the eyes.

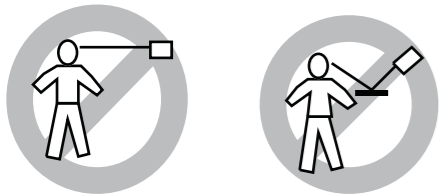

Labelling: IDEC laser sensors include **CDRH-approved** safety warnings shown below, in compliance with federal regulations of the **Center for Devices and Radiological Health**.

MX1C Miniature Laser Sensor:
Class IIIa Laser (670nm) Visible Beam

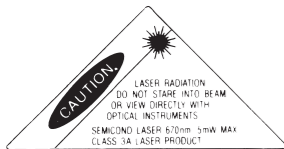

All Laser Sensors:
Identification and Certification

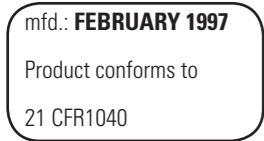

MX1C Visible Laser:
Aperture Warning

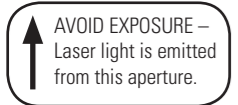

General Information

Specifications

Do not operate a sensor under any conditions exceeding these specifications.

Do not operate a sensor under current and voltage conditions other than those for which the individual sensor is rated.

Do not exceed the recommended operating temperature and humidity. Although sensors are rated for operation below 0°C, this specification does not imply that performance characteristics will remain constant under prolonged freezing conditions. Continued exposure and the accompanying frost, ice, dew, and condensation which accumulate on the optical surface will adversely affect sensor performance.

To maintain performance characteristics, do not exceed vibration and shock resistance ratings while operating a sensor. In addition, avoid impacts to the sensor housing which are severe enough to adversely affect the waterproof characteristics.

IEC (International Electrotechnical Commission) Ratings

Sensors rated IP67 are resistant to moisture when occasionally immersed in water. Sensors rated IP64 through IP66 are resistant to moisture when occasionally subjected to splashing or when located in the vicinity of turbulent waters. These ratings do not imply that a sensor is intended for use under continual high-pressure water spray. Avoid such applications to maintain optimal sensor performance.

Sensors rated IP64 through IP67 are dust-tight and water-tight. For best performance, avoid using any sensor in an area where it will be subjected to heavy particle blasts and where dust, water, or steam will accumulate on the optical surface.

Start-up

Do not test the housing for dielectric strength and insulation resistance, since the housing is connected to the electronic circuit ground of a sensor. Do not perform dielectric strength and insulation resistance tests on electrical systems without disconnecting photoelectric sensors, as such testing may result in damage to the sensor.

Several lines of sensors, as noted in the individual operation sections, are provided with an internal circuit to turn an output off for a specified amount of time upon power-up. This delay is normal; it prevents a transient state when turning power on.

Optimum Performance

The optical surface of each sensor must be cleaned on a regular basis for continual superior performance. Use a soft cloth dipped in isopropyl alcohol to remove dust and moisture build-up.

IMPORTANT: Do not use organic solvents (such as thinner, ammonia, caustic soda, or benzene) to clean any part of a sensor.

All sensors experience signal inconsistencies under the influence of inductive noise. Do not use sensors in close proximity to transformers, large inductive motors or generators. Avoid using sensors in direct contact with sources of excessive heat. Also avoid operation in close proximity to welding equipment.

Light

Visible light is electromagnetic radiation with a wavelength between 390 and 770nm. White light is composed of all the visible spectrum components in equal quantity; the predominance of a specific wavelength determines the color of the light. Light Emitting Diodes (LEDs) are the most common light used in optoelectronics.

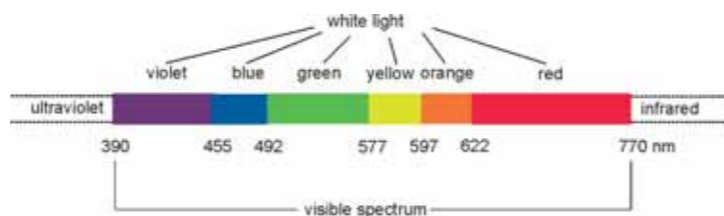

Transmission, Absorption, Reflection

When light hits an object three things take place at the same time: reflection (ρ), absorption (α) and transmission (τ); with parameters and ratios that vary according to the object themselves, which are then further differentiated by material, surface, thickness and/or color. These elements can be detected using a photoelectric sensor.

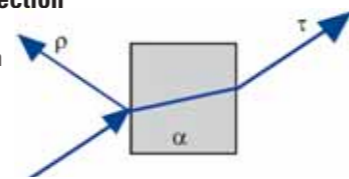

Extraneous Light

Bright, extraneous light such as sunlight, incandescent lights, or fluorescent lights may impair the performance of sensors in detecting color or light.

Make sure that extraneous light does not exceed recommended levels found in the individual specifications sections. When 500 lux is specified, this is equal to 50 footcandles. The average factory illumination is ordinarily below this level, except in areas where visual inspection is being performed. Only in such brightly lit areas is incident light of particular concern.

Unwanted light interference can often be avoided simply by making sure that the optical receiver is not aimed directly toward a strong light source. When mounting direction cannot be adjusted, place a light barrier between all nearby light sources and the receiver.

Through-beam Sensors

With through-beam sensors, the light emitter and receiver are contained in two different housings that are mounted one in front of the other. The light beam emitted by the emitter directly hits the receiver; each object that interrupts the beam is detected. This system is used to obtain large signal differences (when the light directly hits the receiver and when the object interrupts the beam) with the highest Excess Gain and the largest operating distance reaching up to 50m. These sensors can operate in the harshest environmental conditions, such as in the presence of dirt or dust. The disadvantage is that two units have to be wired (an emitter and receiver). The through-beam optic function operates typically in dark mode: the output is activated when the object interrupts the beam between the emitter and receiver.

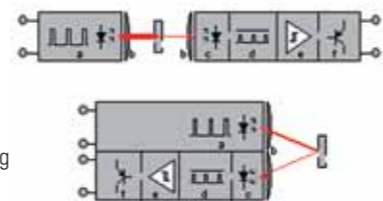

It is strongly recommended to avoid using any sensor where it will be continually subjected to elements which impair performance or cause corrosive damage to the sensor. In particular, avoid strong vibrations and shocks, corrosive gases, oils and chemicals, as well as blasts of water, steam, dust or other particles.

A slit attachment is available to modify the beam size of through-beam sensors. This option is recommended for detecting very small objects (near the size of the smallest object which a sensor can detect) or for eliminating light interference when sensors are mounted in close proximity.

Retro-reflective

Photoelectric sensors with this function contain both the emitter and receiver inside the same housing. The emitted light beam is reflected on the receiver due to a prismatic reflector; an object is detected when it interrupts the beam. Compared to the through-beam optic function, the signal difference is reduced (when the light is freely reflected by the reflector and when an object interrupts the beam) so Excess Gain is reduced and maximum operating distances can reach 12 meters. It is necessary to operate in clean environments without dirt or dust. A retro-reflective sensor typically operates in the dark mode: output is activated when an object interrupts the light beam between the sensor and reflector.

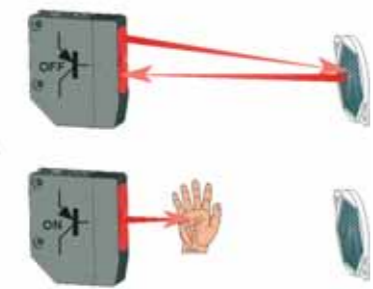

When installing sensors which detect reflected light, make sure that unwanted light reflections from nearby surfaces, such as the floor, walls, reflective machinery or stainless steel, do not reach the optical receiver.

Also, make sure that reflected-light sensors mounted in close proximity do not cause interfering reflections. When it is not possible to maintain the recommended clearance between sensors, as noted in the individual installation sections, provide light barriers between sensors.

Prismatic Reflector

A prismatic reflector is able to reflect incident light in a parallel manner, with a reflection coefficient higher than any other object for angles less than 15°. Typically the operating distance proportionally increases according to the reflector's dimensions. The reflector can rotate the incident light's polarization plane at 90°.

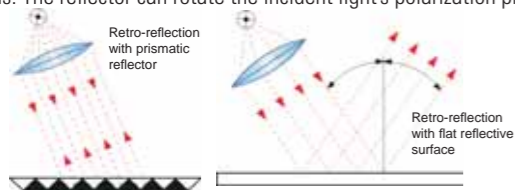

Polarized Retro-reflective

In presence of critical detection of objects with very reflective surfaces, such as shiny metals or mirrored glass, retroreflex sensors with polarized filters have to be used. In polarized retroreflex sensors, the emission light is polarized on a vertical plane, while the reception is obtained only through a polarized filter on a horizontal plane. A prismatic reflector rotates the light plane at a right angle, while the light reflected from the object maintains polarization plane unvaried and is blocked by the filter placed on the receiver. Consequently, only the light reflected by the prismatic reflector is received.

Retro-reflective for Transparent Objects

For detection of transparent objects, such as PET bottles or Mylar sheets, a low-hysteresis retro-reflective sensor (capable of detecting small signal differences) can be used. These sensors detect small signal differences that the light undergoes when it passes through a transparent object.

Diffuse Proximity

Photoelectric sensors with this function contain both the emitter and receiver inside the same housing. The emitted light beam is reflected on to the receiver directly by the object, which is detected without the need of prismatic reflectors. Proximity sensors represent the most economic and fastest mounting solution. However, they work with weaker signals compared to retro-reflective sensors. Excess Gain is reduced and operating distance, depending on the object's reflection degree, can only reach 2 meters.

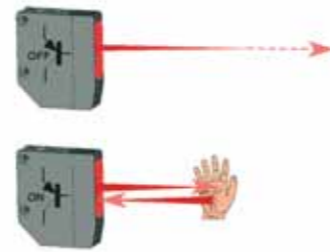

A proximity sensor normally operates in light mode: the output is activated when an object enters the detection area and reflects light emitted by the sensor.

Background Suppression

Background suppression sensors allow the operator to precisely set the maximum detection distance. The operating distance adjustment is not based upon the receiver's sensitivity, but is obtained through optic triangulation, mechanically acting on the lenses or photoelements angle or electronically using PSD (Position-Sensitive Detectors) receiving systems. Consequently the detection of an object is independent of other objects behind (or in the background), which are suppressed. Moreover, due to this adjustment method, all objects can be detected at the same distance independent of their color.

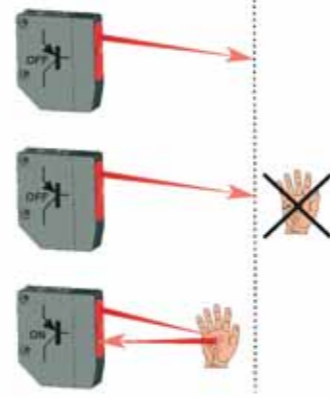

Distance Sensors

Distance sensors supply an analog signal of 0-10V or 4-20mA proportional to the measurement of the distance between the emitting optics and the target.

The main technologies involved are optic triangulation and time-of-flight. The first allows very precise measurements on short distances, while the second is ideal for medium and long distances.

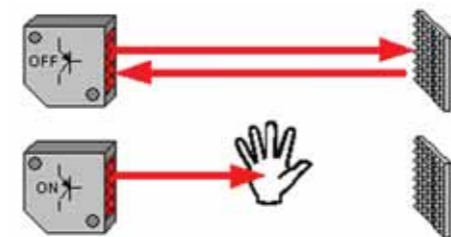

Slot Sensors



A slot sensor is a version of a through-beam retro-reflective sensor, where the emitter and receiver are placed opposite each other on the inside of an U-shaped housing. Any target that passes through the internal slot interrupts the beam and is detected. Due to their construction, slot sensors are great for applications with short operating distances. The most typical slot sensor applications are hole or teeth detection on gears, label detection, or edge control and continuity of sheets or tapes. The emission is generally infrared light; however visible red or green emission versions are available and able to detect references such as registration marks, that present color contrasts on transparent film.

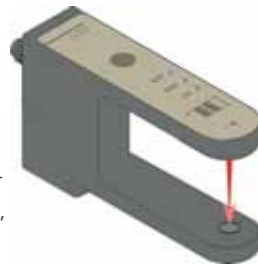

Contrast Sensors



Contrast sensors (also defined as color mark readers) present a proximity function but, instead of detecting only the presence or absence of an object, they are able to distinguish between two surfaces. This is accomplished by detecting the contrast produced by the different reflection degrees. In this manner a dark reference mark (low reflection) can be detected due to the contrast with a lighter surface (high reflection), or vice versa. In the presence of colored surfaces, the contrast is highlighted using an LED, typically red or green. For general purposes a white light is used because the full light spectrum detects the majority of contrasts. White light emission is obtained through lamps, or LEDs in most sensors, enabling the detection of very slight contrasts due to different surface treatments, even of the same material and color.

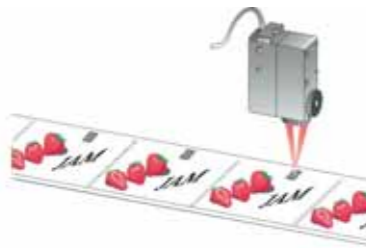

Contrast sensors are mainly used in automatic packaging machines for registration mark detection to synchronize folding, cutting and welding.

Contrast on White Background			
Mark Color	Red LED	Green LED	White LED
Red	no	medium	medium
Orange	low	medium	medium
Yellow	low	low	medium
Green	high	no	medium
Blue	high	medium	high
Violet	medium	high	high
Brown	low	medium	high
Black	high	high	high
Gray	medium	medium	medium
White	no	no	yes

Luminescence Sensors



'Luminescence' is defined as visible light emission from fluorescent or phosphorous substances, due to electromagnetic radiation absorption. Luminescence sensors emit ultraviolet light, which is reflected at a higher wavelength (minor energy) on a fluorescent surface, shifting into the visible light spectrum. Ultraviolet light emission is obtained using special lamps, or LEDs in sensors. UV emission is modulated and the visible light reception is synchronized. Maximum immunity against external interferences, such as reflections caused by very shiny surfaces, is obtained. In addition, fluorescent targets, invisible to the human eye, can be detected. Luminescence sensors are used in various industries: detecting labels on glass or mirrors in pharmaceutical and cosmetic fields; selecting tiles marked with fluorescent marks in the ceramic industry; determining the presence of fluorescent glues on paper for automatic packaging; distinguishing cutting and sewing guides in textile manufacturing; checking fluorescent paints or lubricants in mechanical production.

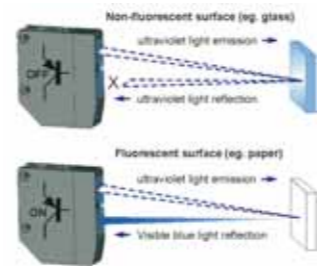

Color Sensors



The color of an object depends on all the color components of the incident light which are being reflected, eliminating those which have been absorbed. The dominant color is defined as 'hue' and depends on the reflected light's wavelength. 'Saturation' indicates the pureness of the color with respect to white and is represented as a percentage. Hue and saturation together are defined as 'chromaticity'.

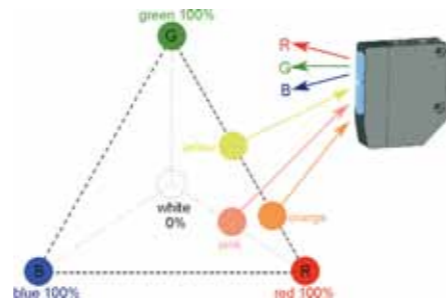

Color or chromatic sensors have a proximity function with generally three RGB LEDs for light emission. The color of an object is identified according to the different reflection coefficients obtained with red (R), green (G) and blue (B) light emissions. More simply, yellow can be identified by R=50% G=50% B=0% reflections; orange by R=75% G=25% B=0% reflections; pink by R=50% G=0% B=0% reflections; but possible combinations are really infinite. Color sensors operate only on reflection ratios and are not influenced by light intensity, defined as 'brilliance' or 'luminance'. There is a wide range of applications, ranging from quality and process controls, to automatic material handling for identification, orientation and selection of objects according to color.

Fiber Optic Sensors



Universal functions of through-beam and proximity sensors, as well as application functions ranging from contrast and luminescence to color detection, can be obtained using fiber optic sensors. The optical fibers can be thought of as cables that transport light and can be used to place the sensor's optics in small spaces, or to detect very small objects.

An optical fiber is composed of cylindrical glass (or a plastic core), surrounded by Teflon or Silicon coating. The difference between the core and the coating refraction indexes allows the light to be diffused inside the fiber in a guided manner. The coating is covered by a plastic or metal sheath, which has an exclusively mechanical protection function. Fibers with a glass core and metal sheath are suitable for very high temperature uses, or for particular mechanical requirements. Plastic fibers, offering great adaptability, are the most diffused in all

applications. Plastic optic fibers have a standard 2.2mm external diameter and generally have a cylindrical threaded metal head on the end used for mechanical mounting. These fibers are usually 1 and 2 meters in length as reductions in performance become significant with lengths over 5 meters. Plastic optic fibers can be shortened using a special fiber-cutting tool, but, it can only be used a limited number of times. Cutting the fiber with a non-sharp or non-perpendicular blade will reduce operating distance. High temperature, extra-flexible or high efficiency plastic optic fibers are also available.

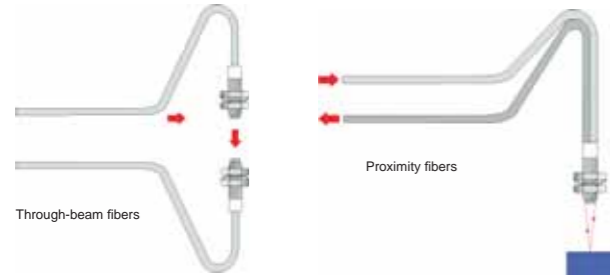

Laser Sensors



A LASER (Light Amplification by Stimulated Emission of Radiation) is an electronic device, such as a diode, that converts an energy source into a very thin and concentrated light beam, suitable for detecting very small objects or to reach very long operating distances. With reference to the safety of laser radiation (according to the EN60825-1 European standard) class 1 requires that the laser device is safe under reasonable operating conditions and is not dangerous for people in any situation; while class 2 states that the eye cannot be protected just by looking away or blinking, thus precautions must be adopted to avoid staring into the beam.



IMPORTANT: Always consider safety when installing a laser sensor of any kind. Make sure that the laser beam cannot inadvertently shine into the eyes of people passing by or working in the vicinity. See safety information on page 232.

Mounting

Mounting brackets and hardware are included with sensors, where applicable. Use the hardware for mounting, along with washers and spring washers or lock nuts. Do not overtighten hardware. Overtightening causes damage to the housing and will adversely affect the waterproof characteristics of the sensor.

Best results can be obtained when the sensor is mounted so that the object sensed is in the center of the beam, rather than when the object is located near the edges of the sensing window. In addition, the most reliable sensing occurs when the majority of the objects being sensed are well within the sensing range, rather than at the extreme near and far limits.

Wiring

Avoid running high-voltages or power lines in the same conduit with sensor signal lines. This prevents inaccurate results or damage from induced noise. Use a separate conduit when the influence of power lines or electromagnetic equipment may occur, particularly when the distance of the wiring is extended.

IMPORTANT: Connect the sensor cables and wires as noted in the individual Wiring sections. Failure to connect as shown in wiring diagrams will result in damage to the internal circuit.

When extending sensor cables and wires, make sure to use cables equal or superior to that recommended in the individual specifications sections.

When wiring terminals, be sure to prevent contact between adjoining terminals. When using ring or fork lug terminals, use the insulated sleeve style only. Each sensor terminal can accept only one ring or fork lug terminal.

Power Supply

Noise resistance characteristics are improved when a sensor is grounded to the 0V power terminal. If the 0V power terminal is not at ground potential, use a ceramic 0.01µF capacitor which can withstand 250V AC minimum.



When using a switching power supply, be sure to ground the FG terminal to eliminate high-frequency noise. The power supply should include an insulating transformer, not an autotransformer.

The compact PS5R-A power supply is the perfect companion item for most IDEC sensors. This power supply is only 1.77" (45mm) wide, 3.15" (80mm) tall, and 2.76" (70mm) deep. Call an IDEC representative for more details.

Part Number	Output Ratings
PS5R-A12	12V DC, 0.62A
PS5R-A24	24V DC, 0.32A

Miscellaneous

Strong magnetic fields may detract from the accuracy of the sensing measurements. Avoid mounting a sensor directly to machinery, since the housing is connected to the electronic circuit ground of the sensor. If it is necessary to mount a sensor on machinery, use the insulating plate and sleeve provided.

Glossary

Attenuation: Reduction of beam intensity as a result of environmental factors such as dust, humidity, steam, etc.

Dark on: Output energized when light is not detected by the receiving element. For through-beam sensors, light from the projector is not detected by the receiver when an object is present. For reflected light sensors, light is not detected when it is not reflected from an object surface.

Diffuse-reflected light sensors: Sensors that detect all scattered and reflected light. Light reflected from nearby surfaces, as well as the intended object surface, is detected. Diffuse-reflected light sensors are often called “proximity switches,” since they switch when any object is near. Also use to detect color contrast when colors reflect light intensity differently (green LED recommended for this application).

EEPROM: Acronym which stands for electronically erasable, programmable, read only memory.

Excess gain: Ratio of optical power available at a given projector-to-receiver range divided by the minimum optical power required to trigger the receiver.

Extraneous light: Incident light received by a sensor, not related to the presence or absence of an object being detected. Extraneous light is usually unwanted background light such as sunlight and incandescent lamps in close proximity.

ΔE : The measurement of color difference as a three-variable function, located on an XYZ axis of light, hue, and chroma values.

Hysteresis: The lag in response shown by an object in reacting to changes in the forces affecting it. Operating point and release point at different levels. For solid state sensors, this is accomplished electrically. For mechanical switches, it results from storing potential energy before the transition occurs.

Light on: Output energized when light is detected by the receiving element. For through-beam sensors, light from the projector is detected by the receiver when an object is not present. For reflected light sensors, light is detected when it is reflected from an objects surface.

Linearity: The measure of the extent to which a certain response is directly proportional to the applied excitation.

NPN/PNP: Types of open collector transistors. NPN is a sink transistor; output on establishes negative potential difference. PNP is a source transistor; output on establishes positive potential difference.

Polarizing: Filtering out all reflected light except that which is projected in one plane only. Polarized retro-reflected light sensors detect the light from corner-cube type reflectors when an object is not present.

Reflected-light sensors: Sensors with the projector and receiver in one housing. Light is projected by the light source, and reflected light is received by the optical surface. Includes diffuse-reflected, retro-reflected, limited-reflected, and spot-reflected sensors.

Repeatability: Ability of a sensor to reproduce output readings consistently when the same value is applied consecutively, in the same direction, for a specified number of cycles, or for a specified time duration.

Resolution: Overall dimension of the smallest object which can be detected (when sensing the presence of an object) or smallest increment of distance which can be distinguished with reliable results (when sensing the position of an object).

Response time: Time elapsed between input and output. Total response time is the sum of object detection, amplifier response, and output response times.

Retro-reflective: This type of reflected light sensor uses a special reflector to return projected light when an object is not present. Sensor detects the presence of an object when the light is reflected differently.

Through-beam sensors: Sensors with a separate projector and receiver. The light source from the projector is detected by the receiver, except when an object is present.

Transient: Undesirable surge of current (many times larger than normal current) for a very short period, such as during the start-up of an inductive motor.

Index
A

- Area Sensors
 - AS1, 94
 - DS1, 98
- AS1 Series, 94
 - area sensor, 94
 - dimensions, 95
 - operating distance, 96
 - part number, 97
 - specifications, 96

C

- Color Sensors
 - S65-V, 62
 - SA1J
 - full color recognition, 67
 - SA1J-F
 - fiber optic, 69
- Compact Sensors
 - S60, 11
 - S62, 24
 - SA1E, 61
- Contrast Sensors
 - TL46, 72

D

- Distance Sensors
 - MX1C, 90
 - SA1D, 87
- DPRI Series, 101
 - dimensions, 101
 - magnetic, 101
 - part number, 102
 - specifications, 102
- DS1 Series, 98
 - area sensor, 94
 - detection diagrams, 100
 - dimensions, 99
 - part numbers, 100
 - specifications, 100

F

- Fiber Optic Sensors
 - high-speed
 - SA1C-F, 41
 - SA1C-FK, 38
- Fork Sensors
 - SR21, 80

G

- General Information, 107

L

- Laser Safety, 106
- LD46 Series, 76
 - detection diagrams, 79
 - dimensions, 77
 - luminescence sensor, 76
 - part number, 79
 - specifications, 78
- Luminescence Sensors
 - LD46, 76

M

- Magnetic Sensors
 - DPRI, 101
- Miniature Sensors
 - SA1E, 32
- Multifunction Optoelectronic Sensors
 - S60, 11
- MX1C Series, 90
 - dimensions, 90
 - distance sensor, 90
 - part numbers, 92
 - specifications, 91

S

- S51-PA, 10
- S51 Series, 7
 - accessories, 45
 - detection diagrams, 9
 - dimensions, 8
 - operating distance, 10
 - part numbers, 10
 - specifications, 9
 - tubular sensor, 7
- S60-PA, 23
- S60 Series, 11
 - accessories, 45
 - coaxial polarized retro-reflective for transparent objects sensor, 16
 - detection diagrams, 17
 - operating distance, 17
 - specifications, 17
 - compact sensor, 11
 - diffuse proximity sensor, 18
 - detection diagrams, 19
 - operating distance, 19
 - specifications, 19
 - long diffuse proximity sensor, 20
 - detection diagrams, 21
 - operating distance, 21
 - specifications, 21
 - part numbers, 23
 - polarized retro-reflective with red emission sensor, 14
 - operating distance, 15
 - specifications, 15
 - specifications, 13, 15, 17, 19, 21
 - technological advantages, 22
 - through-beam with infrared emission sensor, 12
 - detection diagrams, 13
 - operating distance, 13
 - specifications, 13
- S62-PA, 31
- S62-PL, 31
- S62 Series, 24
 - accessories, 45
 - compact sensor, 24
 - detection diagrams
 - laser emission, 30
 - LED emission, 28
 - dimensions, 25
 - emission type, 26
 - high-performance, 24
 - operating distance
 - for models with laser emission, 30
 - part numbers, 31
 - specifications

- for laser emission models, 29
- for LED emission models, 27

- S65-V Series, 62
 - color sensor, 62
 - detection diagram, 65
 - dimensions, 63
 - part numbers, 65
 - specifications, 64
- S80 Series
 - detection diagrams, 86
 - dimensions, 84
 - distance sensor, 83
 - part numbers, 86
 - specifications, 85
- SA1C-FK Series, 40
 - accessories, 45
 - dimensions, 39
 - fiber optic analog sensor, 38
 - part numbers, 40
 - specifications, 39
- SA1C-F Series, 44
 - accessories, 45
 - dimensions, 42
 - high-speed fiber optic sensor, 41
 - part numbers, 44
 - specifications, 42
- SA1D Series, 87
 - dimensions, 87
 - distance, 87
 - part numbers, 89
 - specifications, 88
- SA1E-B, 37
- SA1E-D, 37
- SA1E-G, 37
- SA1E-N, 37
- SA1E-P, 37
- SA1E-T, 37
- SA1E Series, 32
 - accessories, 45
 - compact sensor, 32
 - detection diagrams, 34
 - dimensions, 33
 - miniature photoelectric sensor, 32
 - part numbers, 37
 - specifications, 36
- SA1J-F Series, 66
 - color sensor, 69
 - part numbers, 71
 - specifications, 69
- SA1J/SA1J-F, 66
 - color sensor, 66
- SA1J Series, 66
 - color sensor, 87
 - part numbers, 71
 - specifications, 67
- Sensors, 1
 - application sensors, 4, 5
 - AS1 series, 94
 - color, 62, 66
 - compact, 24, 62
 - contrast, 72
 - digital contrast, 72
 - distance
 - analog, 87
 - self-contained laser displacement, 90
 - DPRI series, 101
 - DS1 series, 98
 - fiber optic analog, 38

- Fork/Slot, 80
- high-speed fiber optic, 41
- laser, 90
- laser distance, 83
- LD46 series, 76
- light grids, 94, 98
- luminescence, 76
- M18 photoelectric sSensors, 7
- magnetic proximity, 101
- micro-processor, 80
- miniature photoelectric, 32
- multifunction optoelectronic sensors, 11
- MX1C series, 90
- S51 series, 7
- S60 series, 11
- S65-V series, 62
- S80 series, 83
- SA1C-FK series, 38
- SA1C-F series, 41
- SA1D, 87
- SA1E series, 32
- SA1J/SA1J-F series, 66
- selection guide, 2
- SR21 series, 80
- time-of-flight measurement, 83
- TL46 series, 72
- universal sensors, 2
- UV LED emission, 76

Slot Sensors

- SR21, 80
- SR21 Series, 80
 - dimensions, 81
 - fork/slot sensor, 80
 - part number, 82
 - specifications, 82

T

- TL46 Series, 72
 - contrast sensor, 72
 - detection diagrams, 75
 - dimensions, 73
 - part number, 75
 - specifications, 74
- Tubular Sensor
 - S51, 7

Optical Sensing Devices



Headquartered in Osaka, Japan, Idec Corporation is a global manufacturer known worldwide for 60 years for its reliable and innovative control and automation products. In the United States, Idec has over thirty local sales offices to assist customers with choosing the right switches, relays, power supplies, PLCs, O/I's, sensors and more. A leader in the industry, Idec produces only the highest quality products. In 2005, Idec received the first Monozukuri Nippon Grand Award, a Prime Ministerial award, from the Japanese government for developing a robot-controlled cell production system, a new paradigm in manufacturing. Idec was commended for the system's excellent productivity and safety, as well as its ability to produce high-quality products. The system, which was built with cutting-edge Idec safety control devices and ergonomic considerations, conforms to ISO12100, and has produced more than 20 million units of control devices from August 2000 to the present.

DATASENSOR, a spin-off from DATALOGIC, was established in Italy over 35 years ago to develop photoelectric sensors for industrial automation. Now, in partnership with Idec, you will have access to these products in the United States. DATASENSOR has won many awards including the prestigious International Best Factory Award in 2005 and 2006, "for exceptional manufacturing and logistic performance achieved through the application of an array of tools and management practices." DATASENSOR is also the third largest photoelectric sensor manufacturer in Europe; Italy's foremost market leader; and the largest manufacturer of 18mm-style tubular photoelectric sensors in the world! In fact, DATASENSOR products are so innovative, they hold over twenty patents and trademarks and boast many brand name customers.



IDEC DATASENSOR website

For additional information on IDEC-DATASENSOR products or DATASENSOR products, visit www.idec-ds.com.



IDEC website

For information on IDEC products, visit www.idec.com/usa.

Find your local IDEC Representative

Visit www.idec.com/usa/locator or call 800-262-IDEC.



Automation & Sensing



Safety & Explosion



Control & Switching



The fastest PLC in its class

IDEC controllers offer speed, power, performance and precision, as well as being easy to use, and easy to maintain. Just a simple, ready-made solution that won't require time you don't have to give. Instead, save time with a reliable product that gives you faster response, better throughput, and less downtime. For more information, visit www.idec.com/plc.

For more information on current IDEC products, visit www.idec.com/usa or call 800-262-IDEC.

For additional information on IDEC-DATASENSOR products or DATASENSOR products, visit www.idec-ds.com.

800-262-IDEC
www.idec.com/usa



Get the power you need

IDEC power supplies offer worldwide approvals, universal voltage inputs, fused inputs, auto-resetting overload protection and various styles. In fact, the new PS5R Slim Line models give you all the power of a traditional power supply in only half the space. Utilize them in tight places or save valuable DIN Rail space while still filling your requirements for power. For more information, visit www.idec.com/powersupply.



Product Support

Technical support:

support@idec.com

Sales support:

sales@idec.com



Think Automation and beyond...

**Complete line of IDEC
 and IDEC-DATASENSOR
 products inside**



www.idec.com

USA
 IDEC Corporation
 Tel: (408) 747-0550
opencontact@idec.com

Canada
 IDEC Canada Ltd.
 Tel: (905) 890-8561
sales@ca.idec.com

Australia
 IDEC Australia Pty. Ltd.
 Tel: +61-3-9763-3244
sales@au.idec.com

Japan
 IDEC Corporation
 Tel: +81-6-6398-2571
products@idec.co.jp

United Kingdom
 IDEC Electronics Ltd.
 Tel: +44-1256-321000
sales@uk.idec.com

Germany
 IDEC Elektrotechnik GmbH
 Tel: +49-40-253054-0
service@idec.de

Hong Kong
 IDEC (H.K.) Co., Ltd.
 Tel: +852-2803-8989
info@hk.idec.com

China/Beijing
 IDEC (Beijing) Corporation
 Tel: +86-10-6581-6131
idec@cn.idec.com

China/Shanghai
 IDEC (Shanghai) Corporation
 Tel: +86-21-5353-1000
idec@cn.idec.com

China/Shenzhen
 IDEC (Shenzhen) Corporation
 Tel: +86-755-8356-2977

Singapore
 IDEC Asia Pte. Ltd.
 Tel: +65-6746-1155
info@sg.idec.com

Taiwan
 IDEC Taiwan Corporation
 Tel: +886-2-2698-3929
service@tw.idec.com

©2007 IDEC Corporation. All Rights Reserved.
 Catalog No. DS9Y-C100-0 9/07 15K

Specifications and other descriptions in this catalog are subject to change without notice.

Optical Sensing Devices

X-ON Electronics

Largest Supplier of Electrical and Electronic Components

Click to view similar products for [Sensor Fixings & Accessories](#) category:

Click to view products by [Idec](#) manufacturer:

Other Similar products are found below :

[EC18-WELL](#) [SA9Z-F11](#) [E4R-R12A-CS3M010](#) [E4R-R12A-CS3M020](#) [BS-1T](#) [CHITAN](#) [ICAB-1](#) [SA9Z-S07PN02](#) [ECT18-WELL](#) [57142-000](#)
[79450811](#) [T18908](#) [P2435.3](#) [TM1STNTCW69755](#) [FRS2](#) [P2432.3](#) [P2434.3](#) [AS7030B_WRISTBAND](#) [AS7038GB_WRISTBAND](#) [EVAL-](#)
[CHAMBER](#) [EVAL-CHAMBER-10](#) [MB18A](#) [R-6717-4F6](#) [51001R](#) [440148](#) [430233](#) [440101](#) [440102](#) [440121](#) [440122](#) [440131](#) [440132](#)
[440135](#) [440136](#) [440147](#) [XSZB108](#) [Y92E-BC12](#) [Y92E-BC18](#) [843-12AC/DC](#) [844-12AC/DC](#) [771000-6011](#) [771000-6202](#) [812-12AC/DC](#) [834-](#)
[12AC/DC](#) [910G](#) [913G](#) [92.031.9058.1](#) [92.032.9058.1](#) [925G](#) [771000-6010](#) [GN 473-B12-MT](#)