



FEMTOCLOCKS™ CRYSTAL-TO-LVCMOS/LVTTL CLOCK GENERATOR

ICS840001

GENERAL DESCRIPTION



The ICS840001 is a Fibre Channel Clock Generator and a member of the HiPerClocks™ family of high performance devices from IDT. The ICS840001 uses a 26.5625MHz crystal to synthesize either 106.25MHz or 212.5MHz, using the **FREQ_SEL** pin.

The ICS840001 has excellent phase jitter performance, over the 637kHz – 10MHz integration range. The ICS840001 is packaged in a small 8-pin TSSOP, making it ideal for use in systems with limited board space.

FEATURES

- One LVCMOS/LVTTL output, 7Ω typical output impedance
- Crystal oscillator interface designed for 26.5625MHz, 18pF parallel resonant crystal
- Selectable 106.25MHz or 212.5MHz output frequency
- VCO range: 560MHz to 680MHz
- RMS phase jitter @ 106.25MHz, using a 26.5625MHz crystal (637kHz - 10MHz): 0.696ps (typical)
- RMS phase noise at 106.25MHz (typical)

Phase noise:

Offset	Noise Power
100Hz	-94.4 dBc/Hz
1kHz	-119.9 dBc/Hz
10kHz	-130.2 dBc/Hz
100kHz	-131.5 dBc/Hz

- 3.3V operating supply
- -30°C to 85°C ambient operating temperature
- Available in both standard (RoHS 5) and lead-free (RoHS 6) packages

FUNCTION TABLE

Input	Output Frequencies
FREQ_SEL	
0	106.25MHz (Default)
1	212.5MHz

Crystal: 26.5625MHz

BLOCK DIAGRAM

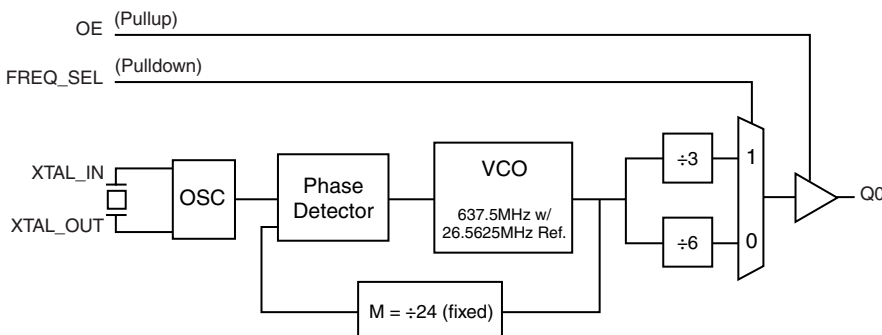

PIN ASSIGNMENT

V _{DDA}	1	8	V _{DD}
OE	2	7	Q0
XTAL_OUT	3	6	GND
XTAL_IN	4	5	FREQ_SEL

ICS840001

8-Lead TSSOP

4.40mm x 3.0mm x 0.925mm
package body
G Package
Top View

TABLE 1. PIN DESCRIPTIONS

Number	Name	Type		Description
1	V _{DDA}	Power		Analog supply pin.
2	OE	Input	Pullup	Output enable pin. When HIGH, Q0 output is enabled. When LOW, forces Q0 to Hi-Z state. LVCMOS/LVTTL interface levels.
3, 4	XTAL_OUT, XTAL_IN	Input		Crystal oscillator interface. XTAL_IN is the input. XTAL_OUT is the output.
5	FREQ_SEL	Input	Pulldown	Frequency select pin. LVCMOS/LVTTL interface levels.
6	GND	Power		Power supply ground.
7	Q0	Output		Single-ended clock output. LVCMOS/LVTTL interface levels. 7Ω typical output impedance.
8	V _{DD}	Power		Core supply pin.

NOTE: *Pullup* and *Pulldown* refers to internal input resistors. See Table 2, Pin Characteristics, for typical values.

TABLE 2. PIN CHARACTERISTICS

Symbol	Parameter	Test Conditions	Minimum	Typical	Maximum	Units
C _{IN}	Input Capacitance			4		pF
C _{PD}	Power Dissipation Capacitance	V _{DD} , V _{DDA} = 3.465V		24		pF
R _{PULLUP}	Input Pullup Resistor			51		kΩ
R _{PULLDOWN}	Input Pulldown Resistor			51		kΩ
R _{OUT}	Output Impedance		5	7	12	Ω

TABLE 3. CONTROL FUNCTION TABLE

Control Inputs	Output
OE	Q0
0	Hi-Z
1	Active

ABSOLUTE MAXIMUM RATINGS

Supply Voltage, V_{DD}	4.6V
Inputs, V_I	-0.5V to $V_{DD} + 0.5V$
Outputs, V_O	-0.5V to $V_{DDO} + 0.5V$
Package Thermal Impedance, θ_{JA}	101.7°C/W (0 mps)
Storage Temperature, T_{STG}	-65°C to 150°C

NOTE: Stresses beyond those listed under Absolute Maximum Ratings may cause permanent damage to the device. These ratings are stress specifications only. Functional operation of product at these conditions or any conditions beyond those listed in the *DC Characteristics* or *AC Characteristics* is not implied. Exposure to absolute maximum rating conditions for extended periods may affect product reliability.

TABLE 4A. POWER SUPPLY DC CHARACTERISTICS, $V_{DD} = V_{DDA} = 3.3V \pm 5\%$, $T_A = -30^\circ\text{C}$ TO 85°C

Symbol	Parameter	Test Conditions	Minimum	Typical	Maximum	Units
V_{DD}	Core Supply Voltage		3.135	3.3	3.465	V
V_{DDA}	Analog Supply Voltage		3.135	3.3	3.465	V
I_{DD}	Power Supply Current				80	mA
I_{DDA}	Analog Supply Current				10	mA

TABLE 4B. LVCMOS/LVTTL DC CHARACTERISTICS, $V_{DD} = V_{DDA} = 3.3V \pm 5\%$, $T_A = -30^\circ\text{C}$ TO 85°C

Symbol	Parameter	Test Conditions	Minimum	Typical	Maximum	Units
V_{IH}	Input High Voltage		2		$V_{DD} + 0.3$	V
V_{IL}	Input Low Voltage		-0.3		0.8	V
I_{IH}	Input High Current	FREQ_SEL	$V_{DD} = V_{IN} = 3.465V$		150	μA
		OE	$V_{DD} = V_{IN} = 3.465V$		5	μA
I_{IL}	Input Low Current	FREQ_SEL	$V_{DD} = 3.465V, V_{IN} = 0V$	-5		μA
		OE	$V_{DD} = 3.465V, V_{IN} = 0V$	-150		μA
V_{OH}	Output High Voltage; NOTE 1		2.6			V
V_{OL}	Output Low Voltage; NOTE 1				0.5	V

NOTE 1: Outputs terminated with 50Ω to $V_{DD}/2$. See Parameter Measurement Information Section, "3.3V Output Load Test Circuit".

TABLE 5. CRYSTAL CHARACTERISTICS

Parameter	Test Conditions	Minimum	Typical	Maximum	Units
Mode of Oscillation		Fundamental			
Frequency			26.5625		MHz
Equivalent Series Resistance (ESR)				50	Ω
Shunt Capacitance				7	pF

TABLE 6. AC CHARACTERISTICS, $V_{DD} = V_{DDA} = 3.3V \pm 5\%$, $T_A = -30^\circ\text{C}$ TO 85°C

Symbol	Parameter	Test Conditions	Minimum	Typical	Maximum	Units
f_{OUT}	Output Frequency	FREQ_SEL = 1	186.66	212.5	226.66	MHz
		FREQ_SEL = 0	93.33	106.25	113.33	MHz
$f_{jit}(\emptyset)$	RMS Phase Jitter (Random); NOTE 1	$f_{OUT} = 106.25\text{MHz}$, (637kHz to 10MHz)		0.696		ps
		$f_{OUT} = 212.5\text{MHz}$, (2.55MHz to 20MHz)		0.458		ps
t_R / t_F	Output Rise/Fall Time	20% to 80%	250		600	ps
odc	Output Duty Cycle	$f_{OUT} = 106.25\text{MHz}$	48		52	%
		$f_{OUT} = 212.5\text{MHz}$	45		55	%

All parameters are characterized @ 212.5MHz and 106.25MHz.

NOTE 1: Please refer to the Phase Noise Plots.

TYPICAL PHASE NOISE AT 106.25MHz

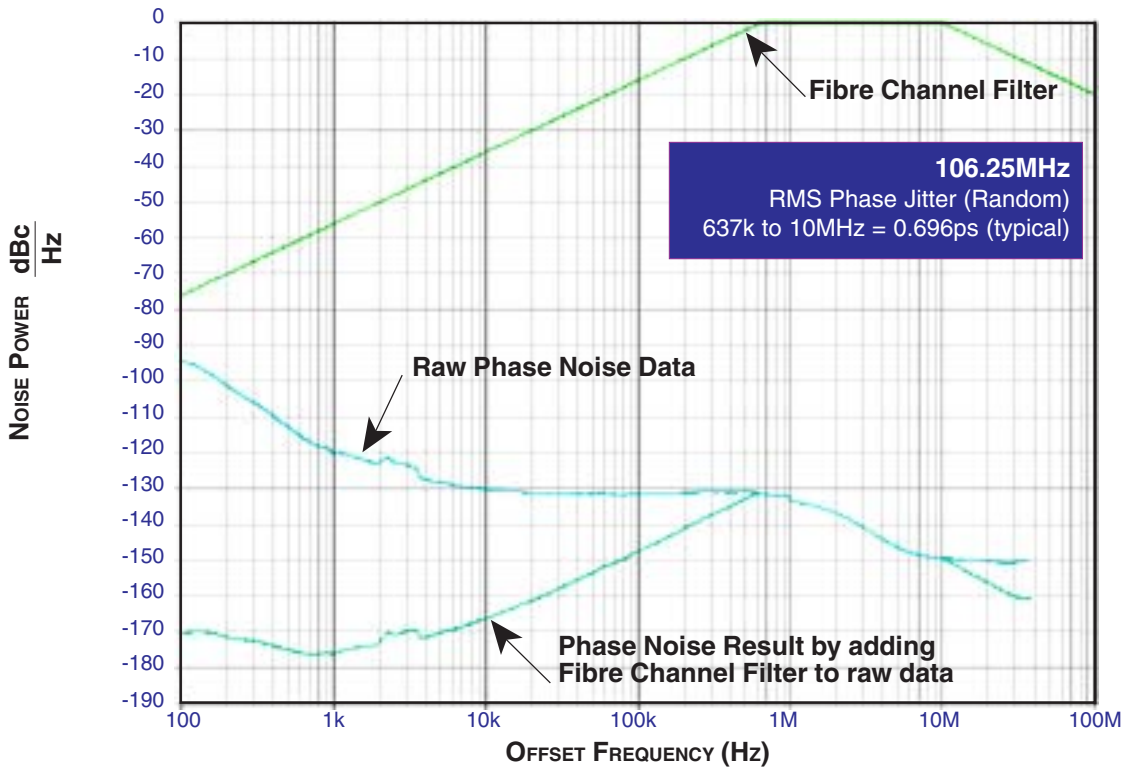

TYPICAL PHASE NOISE AT 212.5MHz

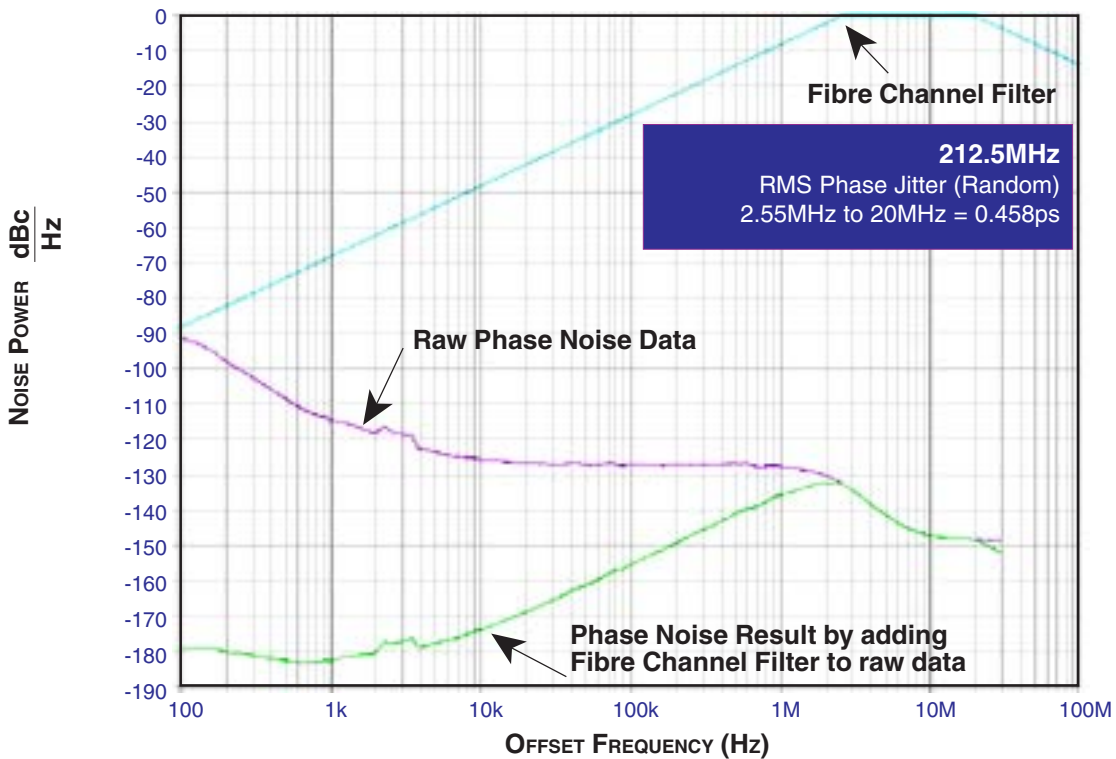

PARAMETER MEASUREMENT INFORMATION

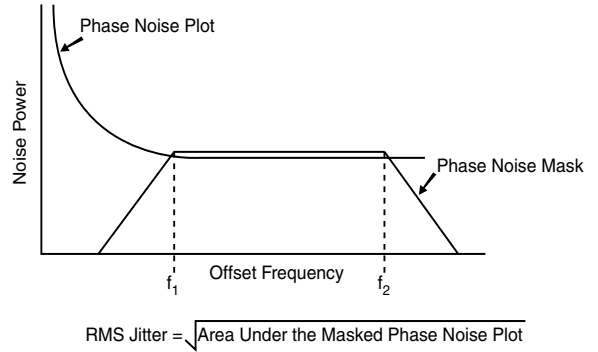
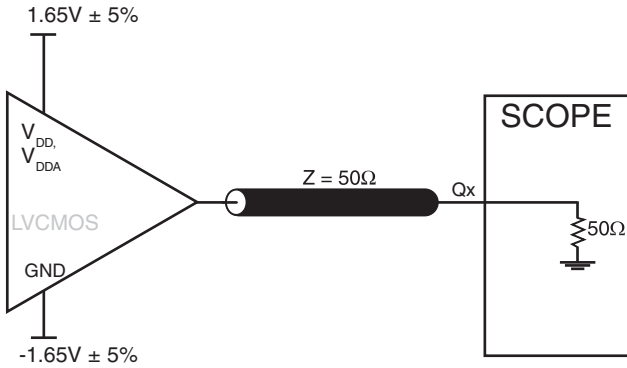

3.3V OUTPUT LOAD AC TEST CIRCUIT

RMS PHASE JITTER

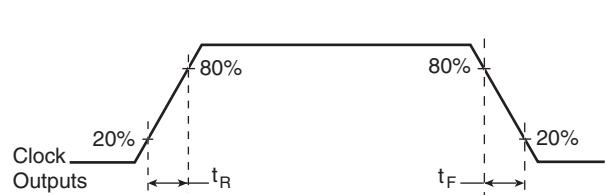
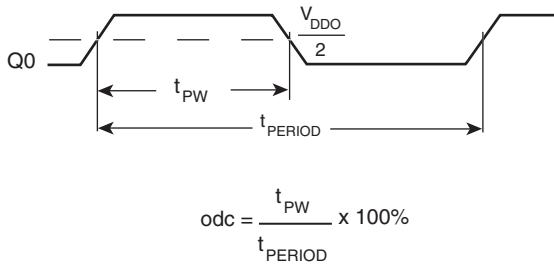

OUTPUT DUTY CYCLE/PULSE WIDTH/PERIOD

OUTPUT RISE/FALL TIME

APPLICATION INFORMATION

POWER SUPPLY FILTERING TECHNIQUES

As in any high speed analog circuitry, the power supply pins are vulnerable to random noise. The ICS840001 provides separate power supplies to isolate any high switching noise from the outputs to the internal PLL. V_{DD} , and V_{DDA} should be individually connected to the power supply plane through vias, and bypass capacitors should be used for each pin. To achieve optimum jitter performance, power supply isolation is required. *Figure 1* illustrates how a 10Ω resistor along with a $10\mu\text{F}$ and a $.01\mu\text{F}$ bypass capacitor should be connected to each V_{DDA} pin.

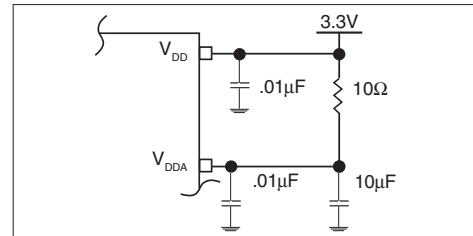

FIGURE 1. POWER SUPPLY FILTERING

RECOMMENDATIONS FOR UNUSED INPUT PINS

INPUTS:

LVCMOS CONTROL PINS

All control pins have internal pull-ups or pull-downs; additional resistance is not required but can be added for additional protection. A $1\text{k}\Omega$ resistor can be used.

CRYSTAL INPUT INTERFACE

The ICS840001 has been characterized with 18pF parallel resonant crystals. The capacitor values, C1 and C2, shown in *Figure 2* below were determined using a 26.5625MHz, 18pF

parallel resonant crystal and were chosen to minimize the ppm error. The optimum C1 and C2 values can be slightly adjusted for different board layouts.

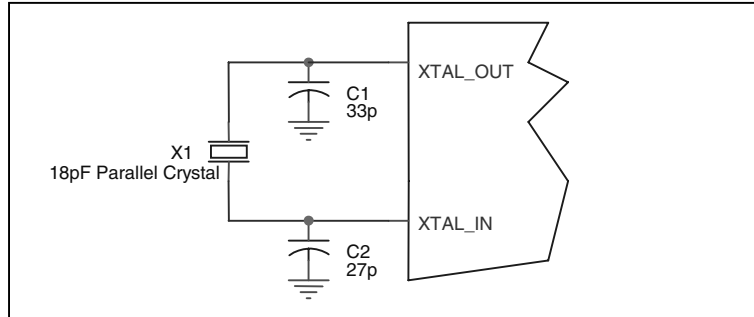

FIGURE 2. CRYSTAL INPUT INTERFACE

LVCMOS TO XTAL INTERFACE

The XTAL_IN input can accept a single-ended LVCMOS signal through an AC coupling capacitor. A general interface diagram is shown in *Figure 3*. The XTAL_OUT pin can be left floating. The input edge rate can be as slow as 10ns. For LVCMOS inputs, it is recommended that the amplitude be reduced from full swing to half swing in order to prevent signal interference with the power rail and to reduce noise. This configuration requires that the output

impedance of the driver (R_o) plus the series resistance (R_s) equals the transmission line impedance. In addition, matched termination at the crystal input will attenuate the signal in half. This can be done in one of two ways. First, R_1 and R_2 in parallel should equal the transmission line impedance. For most 50 Ω applications, R_1 and R_2 can be 100 Ω . This can also be accomplished by removing R_1 and making R_2 50 Ω .

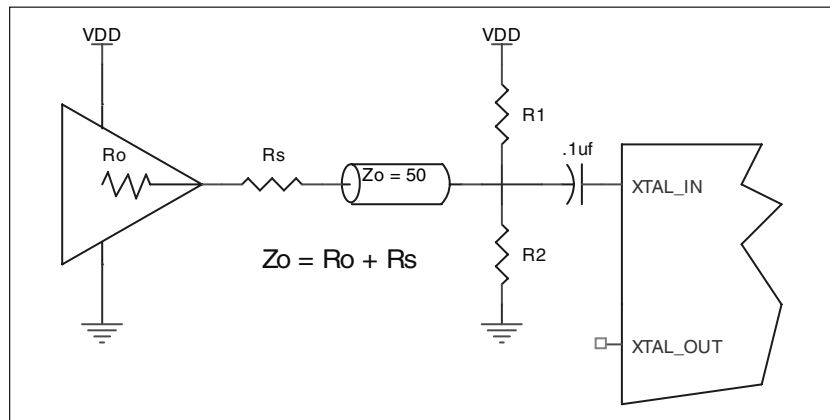

FIGURE 3. GENERAL DIAGRAM FOR LVCMOS DRIVER TO XTAL INPUT INTERFACE

LAYOUT GUIDELINE

Figure 4A shows a schematic example of the ICS840001. An example of LVCMOS termination is shown in this schematic. Additional LVCMOS termination approaches are shown in the LVCMOS Termination Application Note. In this example, an 18 pF parallel resonant 26.5625MHz crystal is used. The C1= 27pF and C2 = 33pF are recommended for frequency accuracy. For different

board layout, the C1 and C2 may be slightly adjusted for optimizing frequency accuracy. The output frequency can be set at either 106.25MHz or 212.5MHz. Leaving the R1 un-installed (or install 1kΩ pull-down) will set the output frequency at 106.25MHz. Installing the R1 pull up will set the output frequency at 212.5MHz.

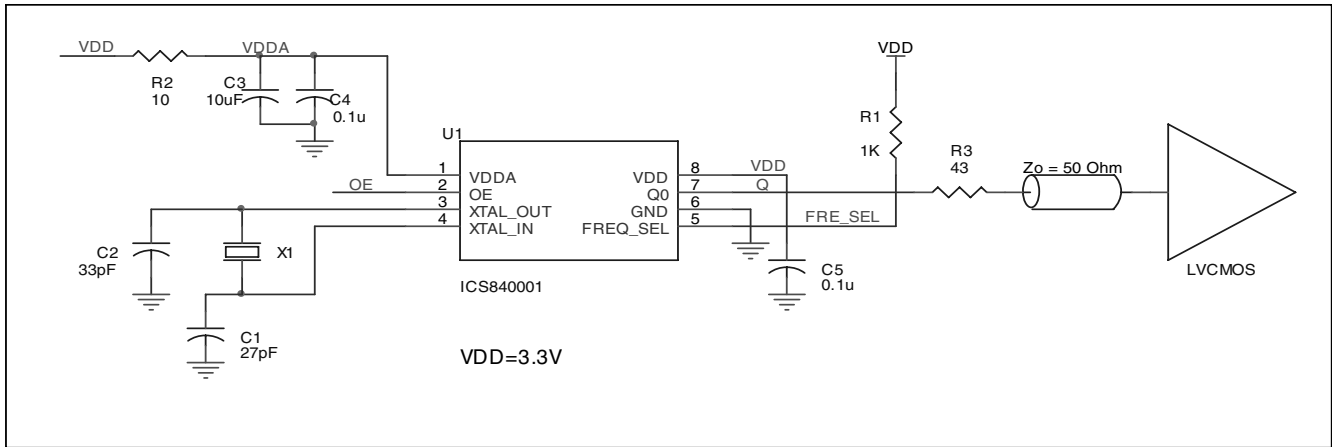

FIGURE 4A. ICS840001 SCHEMATIC EXAMPLE

PC BOARD LAYOUT EXAMPLE

Figure 4B shows an example of P.C. board layout. The crystal X1 footprint in this example allows either surface mount (HC49S) or through hole (HC49) package. C3 is 0805. C1 and C2 are 0402.

Other resistors and capacitors are 0603. This layout assumes that the board has clean analog power and ground planes.

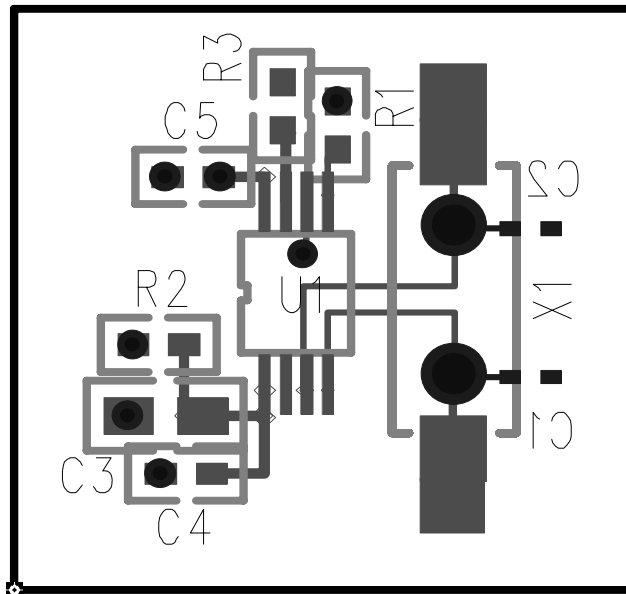

FIGURE 4B. ICS840001 PC BOARD LAYOUT EXAMPLE

RELIABILITY INFORMATION

TABLE 7. θ_{JA} VS. AIR FLOW TABLE FOR 8 LEAD TSSOP

θ_{JA} by Velocity (Meters Per Second)			
	0	1	2.5
Multi-Layer PCB, JEDEC Standard Test Boards	101.7°C/W	90.5°C/W	89.8°C/W

TRANSISTOR COUNT

The transistor count for ICS840001 is: 1521

PACKAGE OUTLINE - G SUFFIX FOR 8 LEAD TSSOP

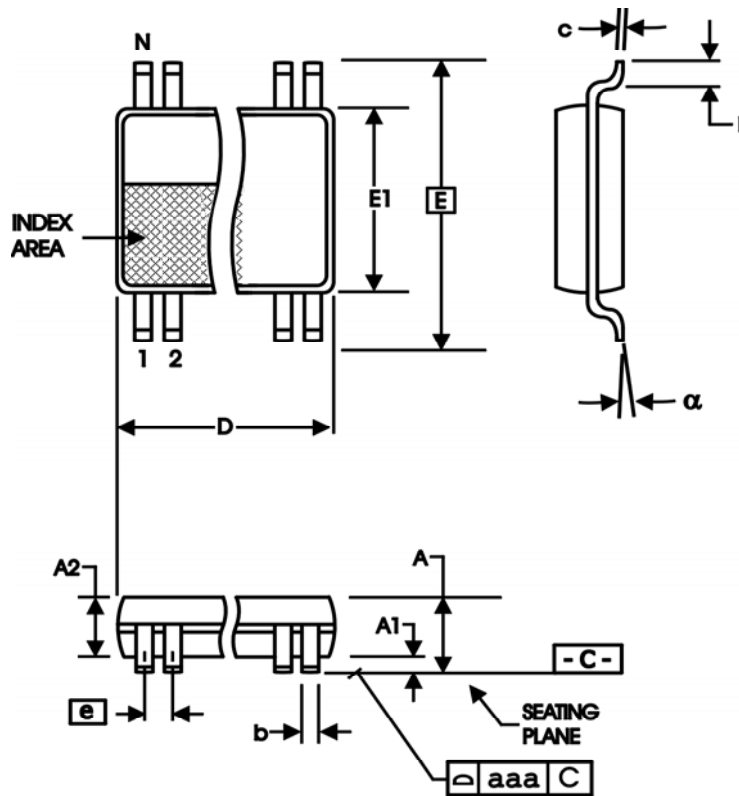

TABLE 8. PACKAGE DIMENSIONS

SYMBOL	Millimeters	
	Minimum	Maximum
N	8	
A	--	1.20
A1	0.05	0.15
A2	0.80	1.05
b	0.19	0.30
c	0.09	0.20
D	2.90	3.10
E	6.40 BASIC	
E1	4.30	4.50
e	0.65 BASIC	
L	0.45	0.75
α	0°	8°
aaa	--	0.10

Reference Document: JEDEC Publication 95, MO-153

TABLE 7. ORDERING INFORMATION

Part/Order Number	Marking	Package	Shipping Packaging	Temperature
ICS840001BG	001B	8 lead TSSOP	tube	-30°C to 85°C
ICS840001BGT	001B	8 lead TSSOP	2500 tape & reel	-30°C to 85°C
ICS840001BGLF	001BL	8 lead "Lead Free" TSSOP	tube	-30°C to 85°C
ICS840001BGLFT	001BL	8 lead "Lead Free" TSSOP	2500 tape & reel	-30°C to 85°C

NOTE: Parts that are ordered with an "LF" suffix to the part number are the Pb-Free configuration and are RoHS compliant.

While the information presented herein has been checked for both accuracy and reliability, Integrated Device Technology, Incorporated (IDT) assumes no responsibility for either its use or for infringement of any patents or other rights of third parties, which would result from its use. No other circuits, patents, or licenses are implied. This product is intended for use in normal commercial applications. Any other applications such as those requiring extended temperature ranges, high reliability or other extraordinary environmental requirements are not recommended without additional processing by IDT. IDT reserves the right to change any circuitry or specifications without notice. IDT does not authorize or warrant any IDT product for use in life support devices or critical medical instruments.

REVISION HISTORY SHEET

Rev	Table	Page	Description of Change	Date
A	T9	11	Ordering Information Table - corrected count from 154 per tube to 100.	10/15/04
A	T7	1	Features Section - added lead-free bullet.	6/13/07
		7	Added <i>Recommendations for Unused Input Pins</i> .	
		8	Added <i>LVCMOS to XTAL Interface</i> .	
		12	Ordering Information Table - added lead-free part number, marking and note.	

Innovate with IDT and accelerate your future networks. Contact:

www.IDT.com

For Sales

800-345-7015
408-284-8200
Fax: 408-284-2775

For Tech Support

netcom@idt.com
480-763-2056

Corporate Headquarters

Integrated Device Technology, Inc.
6024 Silver Creek Valley Road
San Jose, CA 95138
United States
800 345 7015
+408 284 8200 (outside U.S.)

Asia Pacific and Japan

Integrated Device Technology
Singapore (1997) Pte. Ltd.
Reg. No. 199707558G
435 Orchard Road
#20-03 Wisma Atria
Singapore 238877
+65 6 887 5505

Europe

IDT Europe, Limited
321 Kingston Road
Leatherhead, Surrey
KT22 7TU
England
+44 (0) 1372 363 339
Fax: +44 (0) 1372 378851



X-ON Electronics

Largest Supplier of Electrical and Electronic Components

Click to view similar products for [Clock Synthesizer / Jitter Cleaner](#) category:

Click to view products by [IDT](#) manufacturer:

Other Similar products are found below :

[CY28323OXC](#) [MPC9230EIR2](#) [8T49N287A-998NLGI](#) [8T49N286A-999NLGI](#) [PI6CX201ALE](#) [8T49N285A-999NLGI](#) [PL902166USY](#)
[954204CGLF](#) [252MI-52LF](#) [9LPRS485DGLF](#) [8T49N285A-998NLGI](#) [P1P8160AG-10CR](#) [DS31406GN+](#) [PL902167USY](#) [8T49N287A-](#)
[999NLGI](#) [8T49N286A-998NLGI](#) [AD9542BCPZ](#) [8T49N287A-041NLGI](#) [Si5344H-D-GM](#) [8A34001E-000AJG](#) [HMC822LP6CETR](#) [SI5345D-](#)
[A03700-GM](#) [83PN187DKILF](#) [CS230009-CZZ](#) [8T49N287-999NLGI](#) [84330CYLN](#) [83PN625DKILF](#) [83PN156DKILF](#) [MK2703BSLFTR](#)
[954101DFLF](#) [AD9578BCPZ-REEL7](#) [SM802124UMG](#) [8T49N286-999NLGI](#) [840001BGLF](#) [251PMLF](#) [SI5324E-C-GM](#) [SI5324D-C-GM](#)
[PI6CX201ALE](#) [841S101EGILFT](#) [LMK04808BISQ/NOPB](#) [8T49N287-998NLGI](#) [291PGILF](#) [9LRS3165BGLFT](#) [SI2168-D60-GMR](#) [SI5347A-](#)
[B03693-GM](#) [SI5347A-D-GM](#) [SI5347A-D04325-GM](#) [83PN15639ANRGI](#) [8430252CGI-45LF](#) [9LPRS365BGLFT](#)