

drylin® T rail guides | Ordering options



drylin® T replacement plastic slide elements (set)

Material iglidur® J ▶ Page 159

Material iglidur® J200 ▶ Page 261



drylin® T end caps for series O1 guide rail holes:

Guide carriages	Part No. Sliding part set	Rail	Part No. End cap
TW-12-15	TEK-12-15 (J200)	TS-01-15	TSZ-011501
TW-12-20	TEK-12-20 (J200)	TS-01-20	TSZ-012001
TW-12-25	TEK-12-25 (J200)	TS-01-25	TSZ-012501
TW-12-30	TEK-12-30 (J200)	TS-01-30	TSZ-013001

When using the end caps, screws with a low screw head must be used to attach the rail.

Part No.	F _{ymax} , F _{zmax} [N]
TW-01/-12-15	2,000
TW-01/-02/-12-20	3,700
TW-01/-02/-03/-12-25	5,000
TW-01/-02/-12-30	7,000

drylin® T – system design

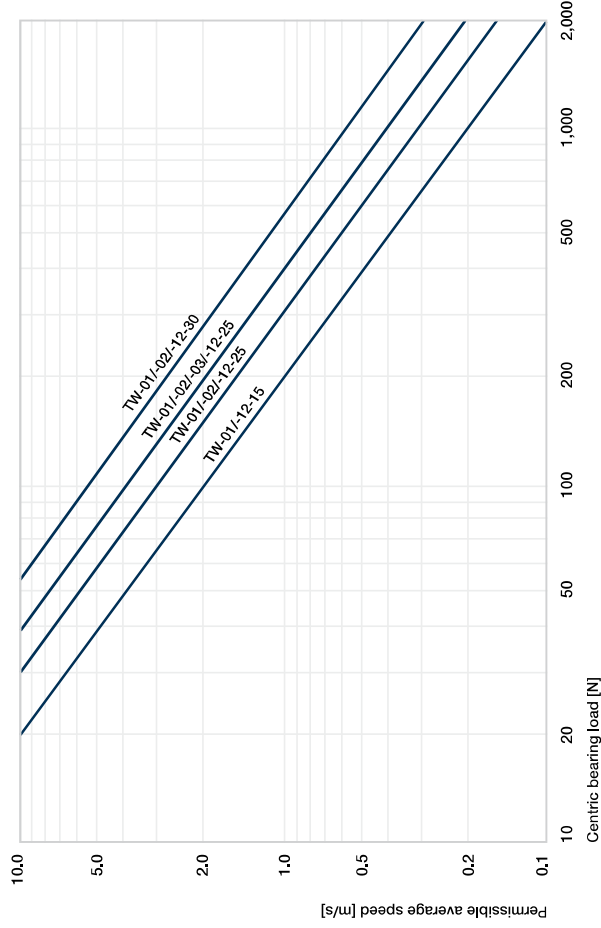

Diagram 04: Determination of the maximum permitted speed for the load



drylin® linear technology – drylin® R shaft guides



Lubrication-free drylin® liners

Resistance to dust and dirt

Low coefficient of friction

Extremely quiet operation

Many adapter and housing options



Hard-anodised aluminium shafts guarantee optimum running properties

Shafts made from steel, stainless steel or carbon fibre

Shafts and supported shafts available

Linear adapter made from solid plastic or aluminium

Complete housing made from anodised aluminium

drylin® liners made from five different lubrication-free iglidur® high-performance polymers

Hard-anodised aluminium tubes – lightweight

Lubrication-free shaft guides – drylin® R

- drylin® R shaft guides are based on extremely wear-resistant polymers specially developed for the linear technology. The dimensions are compatible with standard ball bearings. The special geometry guarantees reliability even in extreme environments.
- 100% lubrication-free
 - Dimensionally interchangeable with standard recirculating ball bearings
 - Large variety of choice in housing shapes
 - Shafts, shaft end blocks and accessories available from stock
 - Replaceable liners
 - Stainless steel housings available

Typical application areas

- Agricultural machinery
- Automotive
- Medical technology
- Facade construction
- Packaging industry



Available from stock

Detailed information about delivery time online.



Price breaks online

No minimum order value. No minimum order quantity.



Max. +200°C
Min. -40°C



Up to Ø 60mm
More dimensions upon request.



Imperial dimensions available

► From page 1612



Service life calculation

► www.igus-asean.com/drylin-expert



ESD-compatible
(electrostatic discharge)



Free from toxins
2011/65/EU (RoHS)



Cleanroom certified
IPA Fraunhofer



Linear plain bearings

- Dimensionally interchangeable with standard recirculating ball bearings
 - Extremely lightweight solid plastic bearing
 - Aluminium and stainless steel adapters equipped with iglidur® liners
- Page 1102



Liners and press-fit bearings

- Made from iglidur® high-performance polymers
 - Easy to fit
 - Unaffected by dirt and dust
 - Low coefficient of friction, optimised wear quality
- Page 1080



Closed pillow blocks

- Pre-assembled linear housing with drylin® liners
 - Material: Anodised aluminium
 - Fixed and floating bearing version available
- Page 1118



Flanged linear plain bearings

- Pre-assembled housings with drylin® liners
 - Round or square flange
 - Tandem flange housing for additional stability
- Page 1130



Linear bearings and pillow blocks, open design

- For supported shafts
 - Round or with housing
 - Clearance adjustment (optional)
- Page 1125

Quad block

- Closed and open design
 - Torque-resistant quad block housing with four linear adapters
 - Also available as tandem housing
- Page 1138



drylin® R linear plain bearings on supported aluminium shafts are used in this grinder to guide the cutting table. The drylin® components stand for extreme dirt resistance, accurate guidance and smooth operation.



Saw mill: linear guide with iglidur® J plastic liner for the angle stops. iglidur® J liners are best suited for most linear applications due to their low wear and low friction properties.



The machine now runs entirely free of troubles for multiple years with drylin® R/JUM-01 linear bearings despite the extremely heavy – duty operation.



By changing over to the drylin® R linear plain bearing, the maintenance rate of this compaction unit could be extended by two years, despite high stressing from powder particles and abrasive agents.



Since the sliding bearing should be maintenance-free, precise, compact, durable and very resilient, liners were mounted directly in the passages of the machine frame.



The production line should be adjusted without setup time being required. drylin® linear guides, which enable precise and fast adjustment, were used for this.



Expert for linear guides: System selection & service life calculation with CAD

Configure linear bearings and calculate their service life – constantly expanded by new sizes and products
Easily calculate the service life of your required linear guide and configure with a few clicks. Select a drylin® system and add the relevant environmental parameters. Select the bearing size, carriage, number and position. Then enter the distance between the rails and the mounting. Define more relevant parameter of the guidance and select a rail length. The results are displayed.



► www.igus-asean.com/drylin-expert



Download the online tool app now



drylin® CAD configurator: Generate complete 3D models for drylin® linear technology according to your specifications

The igus® CAD online configurator gives you the ability to design and save your linear guide as a system, individual components directly as a 3D model in all commonly used formats, or to have these sent by e-mail – free of charge and without registration.



► www.igus-asean.com/drylin-CAD



More information about the products can be found in the igus® download area

- Assembly instructions
- Assembly videos
- System design
- Catalogues



► www.igus-asean.com/downloads

drylin® R linear plain bearings

The drylin® standard round bearings consist of a interchangeable iglidur® J liner that is manufactured to be a mechanical fit into an anodised aluminium adapter. The locating spigot of the liner is carried out by a snap ring groove.

drylin® R linear plain bearings, made from solid plastic, are dimensionally equivalent to standard ball bearings. They are made entirely out of wear-resistant iglidur® J material and can offer technical advantages in addition to the clear price advantage. Thus, applications in which machine parts are primarily stainless steel, e.g. food and filling equipment, are well suited for the use of solid plastic bearings. An additional weight-saving is also easily obtained.

Both versions are designed for the installation in housing holes with the tolerance H7. The mounting is done like in ball bearings with circlips according to DIN 471/472.

The narrow design of the 02 series linear plain bearings, is clipped into the H7 housing hole. Standard commercial 2-component adhesives can be used for this purpose.

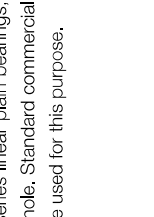
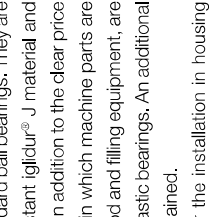

The all-rounder - iglidur® J



The specialist - iglidur® J200



The extreme - iglidur® X



The endurance runner - iglidur® E7



The FDA-compliant - iglidur® A180



Blue Sky Thinking FDA/EU-compliant iglidur® A160

Application temperature	from -50°C to +90°C	from -50°C to +90°C	from -100°C to +250°C	from -50°C to +70°C	from -50°C to +90°C	from -50°C to +90°C
Best coefficient of friction with	Steel shaft	Hard-anodised aluminium	Hard-chromed steel	Steel/stainless steel shaft	Stainless steel shaft	Hardened stainless steel shafts
Volume resistance	> 10 ¹³ Qcm	> 10 ¹³ Qcm	< 10 ⁷ Qcm	> 10 ¹³ Qcm	> 10 ¹³ Qcm	> 10 ¹³ Qcm
Moisture absorption	1.3% weight	0.7% weight	0.5% weight	< 0.1% weight	0.2% weight	< 0.1% weight
Maximum service life with	Hard-anodised aluminium	Hard-anodised aluminium	Hardened stainless steel	Steel/stainless steel shaft	Stainless steel shaft	Hardened stainless steel shafts
Potential counter partner	All shaft materials	Hard-anodised aluminium	Hardened stainless steel	Steel/stainless steel shaft	All shaft materials	Stainless steel
Permissible stat. surface pressure	35MPa	23MPa	150MPa	18MPa	28MPa	15MPa
Part No.	JUM-...	J200UM-...	XUM-...	E7UM-...	A180UM-...	A160UM-...

The split bearings are easily pulled off the housing and opened. The slotted liner can be simply mounted on the shaft. Clip a new bearing liner over the shaft, put the two housing halves together, install - done! With this product range of split drylin® bearings, installation times can be reduced to a minimum.

Series L1 - low-clearance press-fit bearings

The series L1 plain bearings are composed of the iglidur® L100 bearing material, an extremely wear-resistant plastic compound. They are sub-divided into a press-fit area and a gliding range. The gliding range is composed of individual crossbars which are linked to each other by thin film bridges. These film bridges compensate the elongation of the bearing through heating or moisture. This separation enables the almost clearance-free design of the bearings, as there is no clamping of the shaft. The cylinder-shaped press-fit area is also visually very distinct from the gliding range. The function of this area, which shows a distinct clearance compared to the shaft, is to fix the bushing firmly in the housing by means of a press fit.



Compressive strength

igidur® plain bearings are homogeneously filled with solid lubricants. In this way, lubricants cannot be removed, even at high loads. The iglidur® L100 material allows an average static surface pressure of 70MPa. However, only half of the load-bearing surface can carry loads and this is taken into account in the calculation.

Surface speeds

The following table shows possible surface speeds of L1 bearings.

- Extremely high wear resistance
- Low coefficient of friction
- Vibration-dampening
- High static compressive strength
- Good chemical resistance
- Resistant to dirt
- Also suitable for soft and rough shafts

igidur® L100	Rotating	Oscillating	Linear
Continuous [m/s]	1.5	1.5	3
Short-term [m/s]	3	3	10

Table 02: Maximum surface speed for iglidur® L100

Material properties:

- igidur® J ▶ Page 159
- igidur® J200 ▶ Page 261
- igidur® X ▶ Page 279
- igidur® E7 ▶ Page 267
- igidur® A160 ▶ Page 419
- igidur® A180 ▶ Page 401
- igidur® L100 ▶ Page 1654

Coefficient of friction

Plain bearings of the L1 series are designed for dry operation against steel. The best results are attained with surface finishes from 0.3 to 0.8 Ra. The coefficient of sliding friction reduces with increasing load. Typical coefficient of friction in dry operation are 0.2 to 0.3. But the value can be higher with less suitable shafts.

Operating temperatures

Temperatures affect the compressive strength, the wear and the securing of the bearing in the housing. A firm fit could be determined in all the tests up to a temperature of +70°C. At higher temperatures, an additional securing of the bearing is recommended. With effective securing, L1 plain bearings could also be used at temperatures over +130°C.

igidur® L100	Application temperatures
Minimum	-30°C
Max. long-term	+100°C
Maximum, short-term	+190°C

Table 03: Temperature limits for iglidur® L100

Floating bearings for linear plain bearings

drylin® O3 series linear plain bearings offer great advantages in applications with parallel shafts. With their geometry, they are able to compensate for alignment and parallelism errors and should be used on the shaft located furthest from the drive mechanism. The design provides a spherical area on the outside diameter of the aluminium adapter for self-alignment. Reductions in load capacity are prevented, since the shaft always lies on the total projected surface. Due to the even load distribution over the entire bearing, edge pressure is not possible with the self-aligning drylin® linear bearings. In order to compensate parallelism errors between two shafts, the outer diameter is designed to be smaller than the housing hole diameter by 0.2 to 0.3mm (depending on the size). With the use of mounted O-rings, these bearings have an elastic bearing seat. The clearance between the bearing and housing allows for the maximum compensation of possible shaft miss-alignment.

The drylin® R self-aligning bearings are supplied hard-anodised. These surfaces guarantee the highest wear resistance if the aluminium bearing moves in the housing during compensation adjustments. Another option are the pillow blocks in the OJUM-06 LL and RJUM-06 LL design series. The mounting of the bearing allows a parallelism adjustment between the shafts by ±3mm. The particular suspension of the supporting housing on an axis running in the z-direction enables an angular error compensation of up to 3.5°.

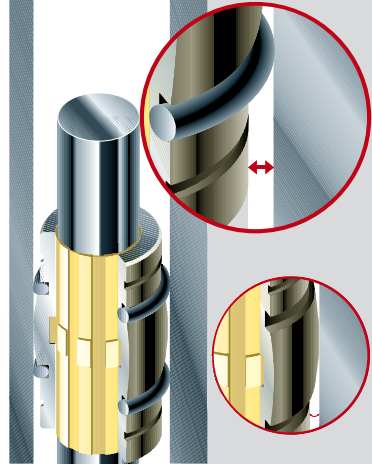

Diagram 02: By defined installation clearance and externally mounted O-rings, the self-aligning drylin® R bearings of the type series 03 can compensate parallelism errors. The spherical drylin® adapter can compensate for parallelism errors. A hard-anodisation protects the aluminium adapter from wear.

Eccentric forces

To ensure successful use of maintenance-free drylin® linear bearings, it is necessary to follow certain recommendations: if the distance between the driving force point and the fixed bearings is more than twice the bearing spacing (2:1 rule), a static friction value of 0.25 can theoretically result in jamming on the guides.

This principle applies regardless of the value of the load or drive force. The friction product is always related to the fixed bearings. The greater the distance between the drive and guide bearings, the higher the degree of wear and required drive force.

Failure to observe the 2:1 rule during a use of linear plain bearings can result in uneven motion or even system blockage. Such situations can often be remedied with relatively simple modifications. If you have any questions on design and/or assembly, please make use of our technical support.

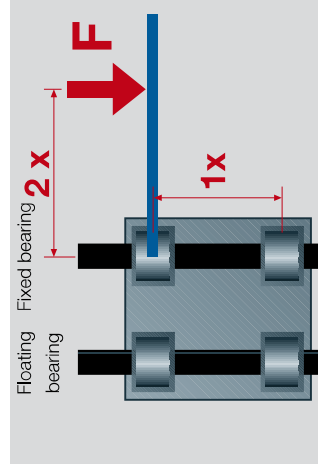

Figure 03: The 2:1 rule



RJUM-06-LL
▶ Page 1124
OJUM-06-LL
▶ Page 1125

RJUM-03/OJUM-03 series ±0.5°
RJUM-06-LL/OJUM-06-LL series ±3.5°

Table 04: Compensation of misalignment errors

RJUM-03/OJUM-03 series	±0.1mm
RJUM-06-LL/OJUM-06-LL series	±3.0mm

Table 05: Compensation of parallelism errors

drylin® R shaft guides are designed for completely lubrication-free operation. The dimensions of the respective linear adapter and housing meet the standard for recirculating ball bearings. During assembly, please note the following installation instructions:

Design tips for drylin® linear plain bearings:

The mentioned values for "F_{max}" relate to the performance of the iglidur® liners made from high-performance plastics and cannot be used as the only selection tool for the calculation of an application. The maximum carrying capacity of the entire bearing system depends on the geometry, housing shape, the housing material, the connection including the screws used and requires a separate inspection. For a detailed analysis, please use our online configurator at

▶ www.igus-asean.com/drylin-expert



Liners:
_UM-01, _UMO-01, _UM-11, _UM-11, _UM-02
● Interlocking with the housing bore
● Locating spigot is supported by a snap ring groove
● Anti-rotation feature through engagement of the pin in hole Ø z



Press-fit bearings:
WLM, WLFM
● Press-fit installation into the H7 housing hole
▶ Assembly instructions, page 57



Linear plain bearings:
RJUM-01, RJUM-11, RJUM-ES, TJUM-01, RJUM-03, TJUM-03, RJUI-01, RJUI-03, TJUI-01, TJUI-03
● Secured by DIN 471 or 472 circlips, metric types (not included)



Solid plastic bearings:
RJM, RJJ-01
● Fastening with circlips according to DIN 471 or 472 (not included)
● The E9 inner tolerance applies only after the press-fit



Solid plastic bearings:
RJMP
● Easy assembly by soft press-fit
● Secured by DIN 471 or 472 circlips (not included)



Linear plain bearings:
RJUM-02
● Secured by press-fit in steel housing hole H7 or aluminium housing hole K7
● Alternatively, the adapter can be glued with commercially available 2-component adhesive into a housing



Compact bearings:
RJ260 (UM-02)
● Locating spigot and press-fit into housing hole H7
● Alternatively, the adapter can be glued with commercially available 2-component adhesive into a housing



Linear plain bearings:
OJUM-01, OJUM-03, OJUI-01, OJUI-03
● Adapter secured with setscrews (not included)



Quad blocks: RQA, RGA, RTA
Tandem design: RTA
● The bearing in the housing is secured by DIN 472 circlips



Linear housings:
RGAS
● The bearing in the housing is secured by DIN 471 circlips



Quad blocks: OGA, OGA, OGA
Linear housings: OGAS, OGAS
Tandem design: OTA
● The bearings is secured by screws



Pillow blocks: RJUM/E7-05, RJUM-06/LL, OJUM/E-06/LL, Flange housings: FJUM/T-07/02
quad blocks: RGA, OGA
Tandem designs: RTA, OTA
Linear bearings: RGAS, OGAS
● Mounting screws of the housing DIN 912-3.8
● Circlips according to DIN 7980

drylin® R liners | Product range

Long, closed design for shafts –
made from iglidur® J (the all-rounder)

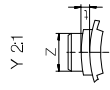
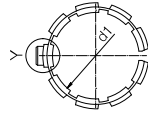
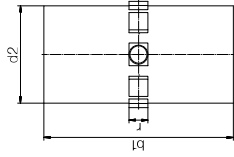

Type	Size
iglidur® J	Inner Ø d1
Liner	Standard
Metric	
J JUM-01-10	



Order key

The all-rounder for all shaft surfaces
in indoor and outdoor applications



⁷⁸⁾ According to iglus® testing method ▶ Page 1146

Please note: Installation instructions ▶ Page 1079



Min. -50°C

Max. +90°C

Dimensions [mm]

d1	d1 tolerance ⁷⁸⁾	d2	b1	r	t	Z	Weight [g]	Part No.
10	+0.030+0.070	12	28	3.0	0.8	2.5	1.10	JUM-01-10
12	+0.030+0.070	14	31	3.0	0.8	3.0	1.50	JUM-01-12
16	+0.030+0.070	18	35	3.5	0.8	3.5	2.20	JUM-01-16
20	+0.030+0.070	23	44	5.0	0.8	3.5	4.90	JUM-01-20
25	+0.030+0.070	28	57	5.0	0.8	4.0	8.23	JUM-01-25
30	+0.040+0.085	34	67	5.0	0.8	4.0	14.95	JUM-01-30
35	+0.040+0.085	39	69	5.0	0.8	4.0	18.20	JUM-01-35
40	+0.040+0.085	44	79	6.0	1.3	5.0	23.16	JUM-01-40
50	+0.050+0.150	55	99	7.0	1.3	6.0	45.35	JUM-01-50
60	+0.050+0.150	65	124	8.0	2.0	6.5	70.00	JUM-01-60 ⁷⁹⁾

Housing hole for JUM-01 | Dimensions [mm]

Shaft Ø	H7	B	h10	r	t	f	Z	Part No.
10	12	29	3.0	1.0	1.0	+0.5	+0.2	JUM-01-10
12	14	32	3.0	1.0	1.5	3.1	3.1	JUM-01-12
16	18	36	3.5	1.0	1.7	3.6	3.6	JUM-01-16
20	23	45	5.0	1.0	2.0	3.6	3.6	JUM-01-20
25	28	58	5.0	1.0	2.0	4.1	4.1	JUM-01-25
30	34	68	5.0	1.0	2.0	4.1	4.1	JUM-01-30
35	39	70	5.0	1.0	2.0	4.1	4.1	JUM-01-35
40	44	80	6.0	1.5	2.5	5.1	5.1	JUM-01-40
50	55	100	7.0	1.5	2.5	6.1	6.1	JUM-01-50
60	65	125	8.0	2.5	3.0	6.5	6.5	JUM-01-60 ⁷⁹⁾

⁷⁹⁾ in two parts

Can be combined with:



RJUM-01-03
TJUM-01-03



RJUM-06-06-LL



FJUM-01-42



FJUM-01-42

Imperial dimensions



▶ Page 1612

drylin® R liners | Product range

Long, open design for supported shafts –
made from iglidur® J (the all-rounder)

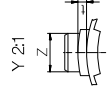
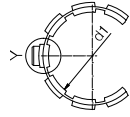
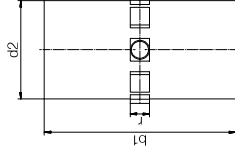

Type	Size
iglidur® J	Inner Ø d1
Liner	Standard
Metric	
J JUMO-01-10	



Order key

The all-rounder for all shaft surfaces
in indoor and outdoor applications



⁷⁸⁾ According to iglus® testing method ▶ Page 1146

Please note: Installation instructions ▶ Page 1079



Min. -50°C

Max. +90°C

Dimensions [mm]

d1	d1 tolerance ⁷⁸⁾	d2	b1	r	t	Z	Weight [g]	Part No.
10	+0.030+0.070	12	28	3.0	0.8	2.5	0.90	JUMO-01-10
12	+0.030+0.070	14	31	3.0	0.8	3.0	1.16	JUMO-01-12
16	+0.030+0.070	18	35	3.5	0.8	3.5	1.71	JUMO-01-16
20	+0.030+0.070	23	44	5.0	0.8	3.5	4.16	JUMO-01-20
25	+0.030+0.070	28	57	5.0	0.8	4.0	6.97	JUMO-01-25
30	+0.040+0.085	34	67	5.0	0.8	4.0	12.38	JUMO-01-30
40	+0.040+0.085	44	79	6.0	1.3	5.0	20.18	JUMO-01-40
50	+0.050+0.150	55	99	7.0	1.3	6.0	38.60	JUMO-01-50
60	+0.050+0.150	65	124	8.0	2.0	6.5	60.10	JUMO-01-60 ⁷⁹⁾

Housing hole for JUMO-01 | Dimensions [mm]

Shaft Ø	H7	B	h10	r	t	f	Z	Part No.
10	12	29	7.3	3.0	1.0	1.0	2.6	JUMO-01-10
12	14	32	9.0	3.0	1.0	1.5	3.1	JUMO-01-12
16	18	36	11.6	3.5	1.0	1.7	3.6	JUMO-01-16
20	23	45	12.0	5.0	1.0	2.0	3.6	JUMO-01-20
25	28	58	14.5	5.0	1.0	2.0	4.1	JUMO-01-25
30	34	68	16.6	5.0	1.0	2.0	4.1	JUMO-01-30
40	44	80	21.0	6.0	1.5	2.5	5.1	JUMO-01-40
50	55	100	25.5	7.0	1.5	2.5	6.1	JUMO-01-50
60	65	125	27.2	8.0	2.5	3.0	6.5	JUMO-01-60 ⁷⁹⁾

⁷⁹⁾ in two parts

Can be combined with:



OJUM-01-03



OJUM-06-06-LL



OJUM-06-06-LL



OJUM-06-06-LL

Imperial dimensions



▶ Page 1612

drylin® R liners | Product range

Long, closed design, precise for shafts – made from iglidur® J (the all-rounder)

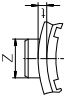
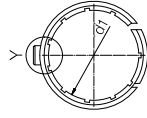
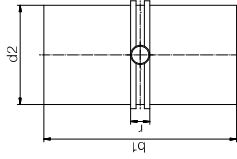
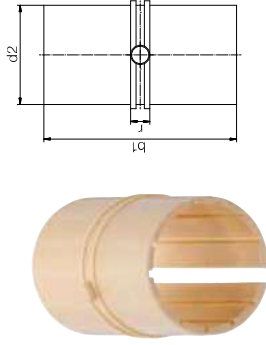

Order key

Type	Size
iglidur® J	Inner Ø d1
Liner	
Metric	
Precise	

J JUM-11-10

- Max. bearing clearance reduced by 50%
- Increased contact surface: longer service life



⁷⁸⁾ According to iglus® testing method ▶ Page 1146
Please note: Installation instructions ▶ Page 1079



Min. -50°C
Max. +90°C

Dimensions [mm]

d1	d1 tolerance ⁷⁸⁾	d2	b1	r	t	Z	Weight [g]	Part No.
10	+0.000 +0.040	12	28	3.0	0.8	2.5	1.23	JUM-11-10
12	+0.000 +0.040	14	31	3.0	0.8	3.0	1.65	JUM-11-12
16	+0.000 +0.040	18	35	3.5	0.8	3.5	2.42	JUM-11-16
20	+0.000 +0.040	23	44	5.0	0.8	3.5	5.49	JUM-11-20
25	+0.000 +0.040	28	57	5.0	0.8	4.0	8.86	JUM-11-25
30	+0.000 +0.050	34	67	5.0	0.8	4.0	16.63	JUM-11-30
40	+0.000 +0.050	44	79	6.0	1.3	5.0	26.06	JUM-11-40
50	+0.000 +0.060	55	99	7.0	1.3	6.0	48.82	JUM-11-50

Housing hole for JUM-11 | Dimensions [mm]

Shaft Ø	di	B	h10	r	t	f	Z	Part No.
10	12	29	3.0	1.0	1.0	+0.5	+0.2	JUM-11-10
12	14	32	3.0	1.0	1.5	3.1	3.1	JUM-11-12
16	18	36	3.5	1.0	1.7	3.6	3.6	JUM-11-16
20	23	45	5.0	1.0	2.0	3.6	3.6	JUM-11-20
25	28	58	5.0	1.0	2.0	4.1	4.1	JUM-11-25
30	34	68	5.0	1.0	2.0	4.1	4.1	JUM-11-30
40	44	80	6.0	1.5	2.5	5.1	5.1	JUM-11-40
50	55	100	7.0	1.5	2.5	6.1	6.1	JUM-11-50

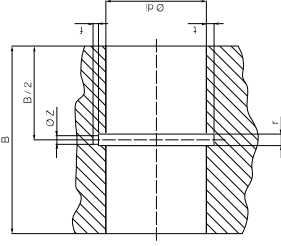

Can be combined with:



RJUM-01-03
TJUM-01-03



RJUM-06-06-LL
FJUM-01-42



FJUM-01-42

drylin® R liners | Product range

Long, open design, precise for supported shafts – made from iglidur® J (the all-rounder)

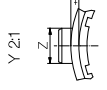
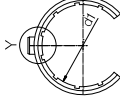
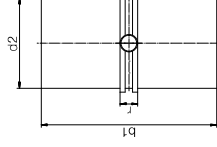

Order key

Type	Size
iglidur® J	Inner Ø d1
Liner	
Metric	
Open	
Precise	

J JUMO-11-10

- Max. bearing clearance reduced by 50%
- Increased contact surface: longer service life



⁷⁸⁾ According to iglus® testing method ▶ Page 1146
Please note: Installation instructions ▶ Page 1079



Min. -50°C
Max. +90°C

Dimensions [mm]

d1	d1 tolerance ⁷⁸⁾	d2	b1	r	t	Z	Weight [g]	Part No.
10	+0.000 +0.040	12	28	3.0	0.8	2.5	1.10	JUMO-11-10
12	+0.000 +0.040	14	31	3.0	0.8	3.0	1.50	JUMO-11-12
16	+0.000 +0.040	18	35	3.5	0.8	3.5	2.20	JUMO-11-16
20	+0.000 +0.040	23	44	5.0	0.8	3.5	4.90	JUMO-11-20
25	+0.000 +0.040	28	57	5.0	0.8	4.0	8.23	JUMO-11-25
30	+0.000 +0.050	34	67	5.0	0.8	4.0	14.95	JUMO-11-30
40	+0.000 +0.050	44	79	6.0	1.3	5.0	23.16	JUMO-11-40
50	+0.000 +0.060	55	99	7.0	1.3	6.0	45.35	JUMO-11-50

Housing hole for JUMO-11 | Dimensions [mm]

Shaft Ø	di	B	W	r	t	f	Z	Part No.
10	12	29	7.3	3.0	1.0	+0.5	+0.2	JUMO-11-10
12	14	32	9.0	3.0	1.0	1.5	3.1	JUMO-11-12
16	18	36	11.6	3.5	1.0	1.7	3.6	JUMO-11-16
20	23	45	12.0	5.0	1.0	2.0	3.6	JUMO-11-20
25	28	58	14.5	5.0	1.0	2.0	4.1	JUMO-11-25
30	34	68	16.6	5.0	1.0	2.0	4.1	JUMO-11-30
40	44	80	21.0	6.0	1.5	2.5	5.1	JUMO-11-40
50	55	100	25.5	7.0	1.5	2.5	6.1	JUMO-11-50

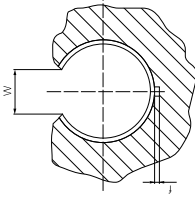
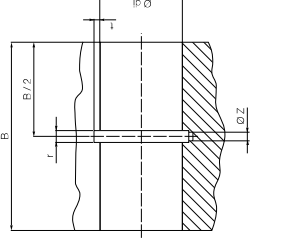

Can be combined with:



OJUM-01-03



OJUM-06-06-LL

drylin® R liners | Product range

Short, closed design for shafts –
made from iglidur® J (the all-rounder)

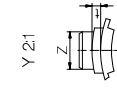
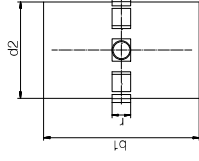

Type	Size
iglidur® J	Inner Ø d1
Liner	
Metric	
Compact	



Order key

The all-rounder for all shaft surfaces
in indoor and outdoor applications



⁷⁸⁾ According to iglus® testing method ▶ Page 1146

Please note: Installation instructions ▶ Page 1079



Min. -50°C

Max. +90°C

Dimensions [mm]

d1	d1 tolerance ⁷⁸⁾	d2	b1	r	t	Z	Weight [g]	Part No.
10	+0.030+0.070	12	25	3.0	0.8	2.5	1.02	JUM-02-10
12	+0.030+0.070	14	27	3.0	0.8	3.0	1.27	JUM-02-12
16	+0.030+0.070	18	29	3.5	0.8	3.5	1.82	JUM-02-16
20	+0.030+0.070	23	29	5.0	0.8	3.5	3.27	JUM-02-20
25	+0.030+0.070	28	39	5.0	0.8	4.0	5.75	JUM-02-25
30	+0.040+0.085	34	49	5.0	0.8	4.0	11.28	JUM-02-30
40	+0.040+0.085	44	59	6.0	1.3	5.0	17.94	JUM-02-40
45	+0.040+0.085	50	59	7.0	1.3	6.0	27.00	JUM-02-45
50	+0.050+0.150	55	69	7.0	1.3	6.0	32.56	JUM-02-50

Housing hole for JUM-02 | Dimensions [mm]

Shaft Ø	di	H7	B	h10	r	t	f	Z	Part No.
10	12	26	3.0	1.0	+0.5	+0.1	1.0	2.6	JUM-02-10
12	14	28	3.0	1.0	1.5	3.1	1.5	3.1	JUM-02-12
16	18	30	3.5	1.0	1.7	3.6	1.7	3.6	JUM-02-16
20	23	30	5.0	1.0	2.0	3.6	2.0	3.6	JUM-02-20
25	28	40	5.0	1.0	2.0	4.1	2.0	4.1	JUM-02-25
30	34	50	5.0	1.0	2.0	4.1	2.0	4.1	JUM-02-30
40	44	60	6.0	1.5	2.5	5.1	2.5	5.1	JUM-02-40
45	50	60	7.0	1.5	2.5	6.1	2.5	6.1	JUM-02-45
50	55	70	7.0	1.5	2.5	6.1	2.5	6.1	JUM-02-50

Can be combined with:



RJUM-02

RJUM-05/RJUME-05
TJUM-05/RJUMT-05

RJUM-01/-02

1084 Online tools and more information ▶ www.igus-asean.com/drylinR



drylin® R liners | Product range

Long, closed design for shafts –
made from iglidur® J200 (the specialist)

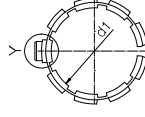
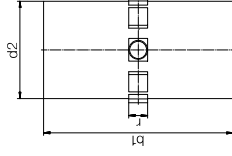

Type	Size
iglidur® J200	Inner Ø d1
Liner	
Metric	
Standard	



Order key

The "specialist" with the best running performance on
aluminium



⁷⁸⁾ According to iglus® testing method ▶ Page 1146

Please note: Installation instructions ▶ Page 1079



Min. -50°C

Max. +90°C

Dimensions [mm]

d1	d1 tolerance ⁷⁸⁾	d2	b1	r	t	Z	Weight [g]	Part No.
10	+0.030+0.070	12	28	3.0	0.8	2.5	1.10	J200UM-01-10
12	+0.030+0.070	14	31	3.0	0.8	3.0	1.50	J200UM-01-12
16	+0.030+0.070	18	35	3.5	0.8	3.5	2.54	J200UM-01-16
20	+0.030+0.070	23	44	5.0	0.8	3.5	5.66	J200UM-01-20
25	+0.030+0.070	28	57	5.0	0.8	4.0	9.51	J200UM-01-25
30	+0.040+0.085	34	67	5.0	0.8	4.0	17.27	J200UM-01-30
40	+0.040+0.085	44	79	6.0	1.3	5.0	26.75	J200UM-01-40
50	+0.050+0.150	55	99	7.0	1.3	6.0	52.38	J200UM-01-50

Housing hole for J200UM-01 | Dimensions [mm]

Shaft Ø	di	H7	B	h10	r	t	f	Z	Part No.
10	12	29	3.0	1.0	+0.5	+0.1	1.0	2.6	J200UM-01-10
12	14	32	3.0	1.0	1.5	3.1	1.5	3.1	J200UM-01-12
16	18	36	3.5	1.0	1.7	3.6	1.7	3.6	J200UM-01-16
20	23	45	5.0	1.0	2.0	3.6	2.0	3.6	J200UM-01-20
25	28	58	5.0	1.0	2.0	4.1	2.0	4.1	J200UM-01-25
30	34	68	5.0	1.0	2.0	4.1	2.0	4.1	J200UM-01-30
40	44	80	6.0	1.5	2.5	5.1	2.5	5.1	J200UM-01-40
50	55	100	7.0	1.5	2.5	6.1	2.5	6.1	J200UM-01-50

Can be combined with:

RJUM-01/-03
TJUM-01/-03RJUM-06/-06-LL
FJUM-01/-02

3D CAD files, prices and delivery time online ▶ www.igus-asean.com/drylinR 1085

drylin® R liners | Product range

Long, open design for supported shafts –
made from iglidur® J200 (the specialist)

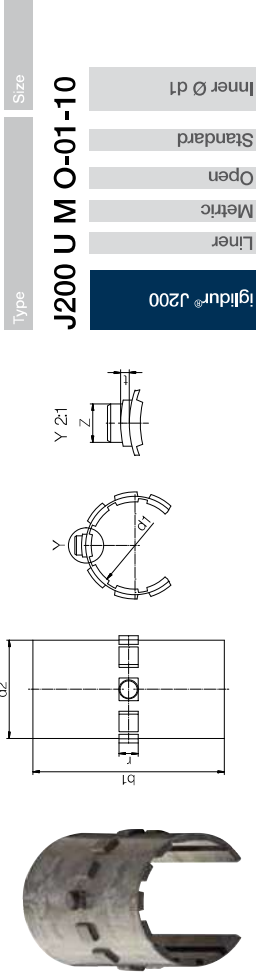

Type	Size
Liner	Inner Ø d1
Metric	Standard
Open	
J200 U M O-01-10	iglidur® J200

The "specialist" with the best running performance on
aluminium

⁷⁸⁾ According to igus® testing method ▶ Page 1146
Please note: Installation instructions ▶ Page 1079

Min. -50°C
Max. +90°C

Dimensions [mm]

d1	d1 tolerance ⁷⁸⁾	d2	b1	r	t	Z	Weight [g]	Part No.
10	+0.030+0.070	12	28	3.0	0.8	2.5	1.04	J200UMO-01-10
12	+0.030+0.070	14	31	3.0	0.8	3.0	1.34	J200UMO-01-12
16	+0.030+0.070	18	35	3.5	0.8	3.5	1.98	J200UMO-01-16
20	+0.030+0.070	23	44	5.0	0.8	3.5	4.80	J200UMO-01-20
25	+0.030+0.070	28	57	5.0	0.8	4.0	8.05	J200UMO-01-25
30	+0.040+0.085	34	67	5.0	0.8	4.0	14.30	J200UMO-01-30
40	+0.040+0.085	44	79	6.0	1.3	5.0	23.31	J200UMO-01-40

Housing hole for J200UMO-01 | Dimensions [mm]

Shaft Ø	H7	B	h10	r	t	f	Z	Part No.
10	12	29	7.3	3.0	1.0	1.0	2.6	J200UMO-01-10
12	14	32	9.0	3.0	1.0	1.5	3.1	J200UMO-01-12
16	18	36	11.6	3.5	1.0	1.7	3.6	J200UMO-01-16
20	23	45	12.0	5.0	1.0	2.0	3.6	J200UMO-01-20
25	28	58	14.5	5.0	1.0	2.0	4.1	J200UMO-01-25
30	34	68	16.6	5.0	1.0	2.0	4.1	J200UMO-01-30
40	44	80	21.0	6.0	1.5	2.5	5.1	J200UMO-01-40

Can be combined with:



drylin® R liners | Product range

Long, closed design for shafts –
made from iglidur® E7 (the endurance runner)

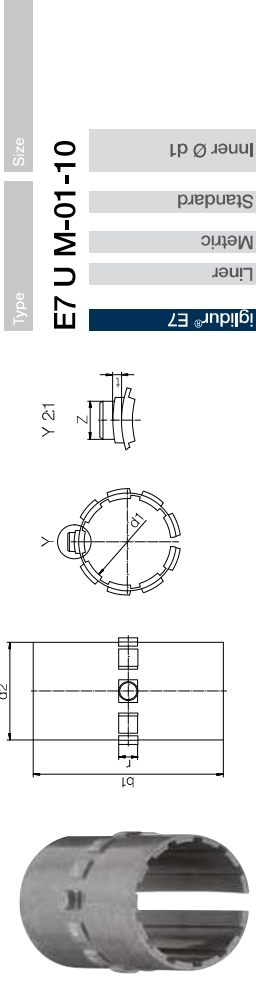

Type	Size
Liner	Inner Ø d1
Metric	Standard
E7 U M-01-10	iglidur® E7

The "endurance runner" up to 8 times longer service
life on steel shafts

⁷⁸⁾ According to igus® testing method ▶ Page 1146
Please note: Installation instructions ▶ Page 1079

Min. -50°C
Max. +70°C

Dimensions [mm]

d1	d1 tolerance ⁷⁸⁾	d2	b1	r	t	Z	Weight [g]	Part No.
10	+0.030+0.070	12	28	3.0	0.8	2.5	0.73	E7UM-01-10
12	+0.030+0.070	14	31	3.0	0.8	3.0	1.01	E7UM-01-12
16	+0.030+0.070	18	35	3.5	0.8	3.5	1.45	E7UM-01-16
20	+0.030+0.070	23	44	5.0	0.8	3.5	3.25	E7UM-01-20
25	+0.030+0.070	28	57	5.0	0.8	4.0	5.44	E7UM-01-25
30	+0.040+0.085	34	67	5.0	0.8	4.0	9.88	E7UM-01-30
40	+0.040+0.085	44	79	6.0	1.3	5.0	17.30	E7UM-01-40
50	+0.050+0.150	55	99	7.0	1.3	6.0	36.30	E7UM-01-50 ⁷⁹⁾
60	+0.050+0.150	65	124	8.0	2.5	6.5	54.80	E7UM-01-60 ⁷⁹⁾

Housing hole for E7UM-01 | Dimensions [mm]

Shaft Ø	H7	B	h10	r	t	f	Z	Part No.
10	12	29	3.0	1.0	1.0	1.0	2.6	E7UM-01-10
12	14	32	3.0	1.0	1.5	3.1	3.1	E7UM-01-12
16	18	36	3.5	1.0	1.7	3.6	3.6	E7UM-01-16
20	23	45	5.0	1.0	2.0	3.6	3.6	E7UM-01-20
25	28	58	5.0	1.0	2.0	4.1	4.1	E7UM-01-25
30	34	68	5.0	1.0	2.0	4.1	4.1	E7UM-01-30
40	44	80	6.0	1.5	2.5	5.1	5.1	E7UM-01-40
50	55	100	7.0	1.5	2.5	6.1	6.1	E7UM-01-50 ⁷⁹⁾
60	65	125	8.0	2.5	3.0	6.5	6.5	E7UM-01-60 ⁷⁹⁾

⁷⁹⁾ in two parts

Can be combined with:



Imperial dimensions
▶ Page 1612

drylin® R liners | Product range

Long, open design for supported shafts – made from iglidur® E7 (the endurance runner)



Order key

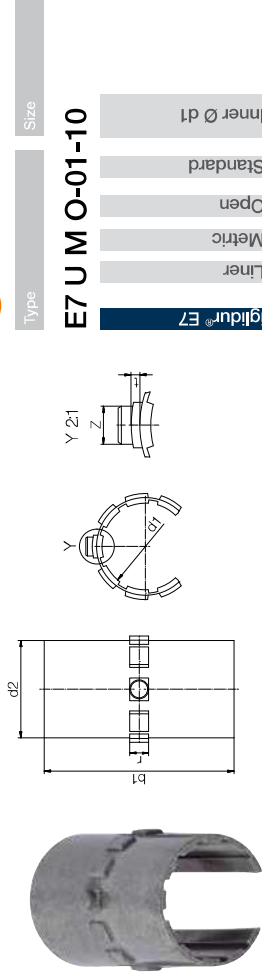

Type

Size

E7 U M O-01-10

Liner

Metric

Open

Standard

Inner Ø d1

iglidur® E7

The "endurance runner" up to 8 times longer service life on steel shafts



⁷⁸⁾ According to iglus® testing method ▶ Page 1146

Please note: Installation instructions ▶ Page 1079



Min. -50°C

Max. +70°C

Dimensions [mm]

d1	d1 tolerance ⁷⁸⁾	d2	b1	r	t	Z	Weight [g]	Part No.
10	+0,030+0,070	12	28	3,0	0,8	2,5	0,73	E7UMO-01-10
12	+0,030+0,070	14	31	3,0	0,8	3,0	1,01	E7UMO-01-12
16	+0,030+0,070	18	35	3,5	0,8	3,5	1,45	E7UMO-01-16
20	+0,030+0,070	23	44	5,0	0,8	3,5	3,25	E7UMO-01-20
25	+0,030+0,070	28	57	5,0	0,8	4,0	5,44	E7UMO-01-25
30	+0,040+0,085	34	67	5,0	0,8	4,0	9,88	E7UMO-01-30
40	+0,040+0,085	44	79	6,0	1,3	5,0	17,30	E7UMO-01-40
50	+0,050+0,150	55	99	7,0	1,3	6,0	36,40	E7UMO-01-50 ⁷⁹⁾
60	+0,050+0,150	65	124	8,0	2,5	6,5	54,80	E7UMO-01-60 ⁷⁹⁾

Housing hole for E7UMO-01 | Dimensions [mm]

Shaft Ø	d1	H7	B	h10	r	t	f	Z	Part No.
10	12	29	7,3	3,0	1,0	1,0	2,6	+0,2	E7UMO-01-10
12	14	32	9,0	3,0	1,0	1,5	3,1		E7UMO-01-12
16	18	36	11,6	3,5	1,0	1,7	3,6		E7UMO-01-16
20	23	45	12,0	5,0	1,0	2,0	3,6		E7UMO-01-20
25	28	58	14,5	5,0	1,0	2,0	4,1		E7UMO-01-25
30	34	68	16,6	5,0	1,0	2,0	4,1		E7UMO-01-30
40	44	80	21,0	6,0	1,5	2,5	5,1		E7UMO-01-40
50	55	100	25,5	7,0	1,5	2,5	6,1		E7UMO-01-50 ⁷⁹⁾
60	65	125	27,2	8,0	2,5	3,0	6,5		E7UMO-01-60 ⁷⁹⁾

⁷⁹⁾ in two parts

Can be combined with:



OJUM-01-03 OJUM-06F-06-LL

drylin® R liners | Product range

Short, closed design for shafts – made from iglidur® E7 (the endurance runner)



Order key

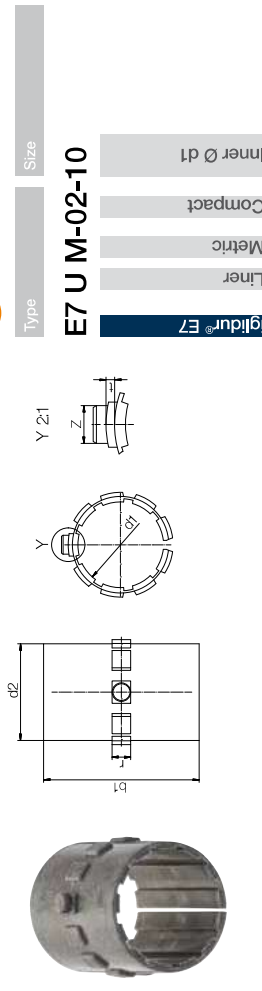

Type

Size

E7 U M-02-10

Liner

Metric

Compact

Inner Ø d1

iglidur® E7

The "endurance runner" up to 8 times longer service life on steel shafts



⁷⁸⁾ According to iglus® testing method ▶ Page 1146

Please note: Installation instructions ▶ Page 1079



Min. -50°C

Max. +70°C

Dimensions [mm]

d1	d1 tolerance ⁷⁸⁾	d2	b1	r	t	Z	Weight [g]	Part No.
10	+0,030+0,070	12	25	3,0	0,8	2,5	0,73	E7UM-02-10
12	+0,030+0,070	14	27	3,0	0,8	3,0	1,01	E7UM-02-12
16	+0,030+0,070	18	29	3,5	0,8	3,5	1,45	E7UM-02-16
20	+0,030+0,070	23	29	5,0	0,8	3,5	3,25	E7UM-02-20
25	+0,030+0,070	28	39	5,0	0,8	4,0	5,44	E7UM-02-25
30	+0,040+0,085	34	49	5,0	0,8	4,0	9,88	E7UM-02-30
40	+0,040+0,085	44	59	6,0	1,3	5,0	17,30	E7UM-02-40

Housing hole for E7UM-02 | Dimensions [mm]

Shaft Ø	d1	H7	B	h10	r	t	f	Z	Part No.
10	12	26	3,0	1,0	1,0	1,0	2,6	+0,2	E7UM-02-10
12	14	28	3,0	1,0	1,5	3,1			E7UM-02-12
16	18	30	3,5	1,0	1,7	3,6			E7UM-02-16
20	23	30	5,0	1,0	2,0	3,6			E7UM-02-20
25	28	40	5,0	1,0	2,0	4,1			E7UM-02-25
30	34	50	5,0	1,0	2,0	4,1			E7UM-02-30
40	44	60	6,0	1,5	2,5	5,1			E7UM-02-40

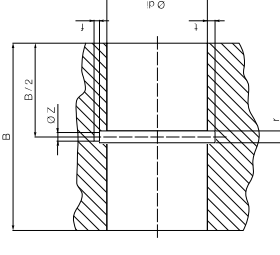

Can be combined with:



RJUM-02 RJUM-05/RJUME-05 FJUMT-01/-02

drylin® R liners | Product range

Long, closed design for shafts, two-piece – made from iglidur® X (the extreme)

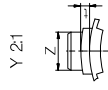
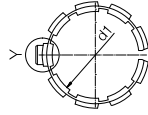
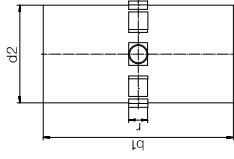

Type **iglidur® X** Size **Inner Ø d1**

Order key

XU M-01-12

Standard
Metric
Liner

The "extreme", resistant to temperature and chemicals on stainless steel and chromed shafts



⁷⁸⁾ According to iglus® testing method ▶ Page 1146

Please note: Installation instructions ▶ Page 1079



Min. -100°C

Max. +250°C

Dimensions [mm]

d1	d1 tolerance ⁷⁸⁾	d2	b1	r	t	Z	Weight [g]	Part No.
12	+0.020+0.060	14	31	3.0	0.8	3.0	1.50	XUM-01-12
14	+0.020+0.060	18	35	3.5	0.8	3.5	2.13	XUM-01-14
16	+0.020+0.060	18	35	3.5	0.8	3.5	2.20	XUM-01-16
20	+0.030+0.070	23	44	5.0	0.8	3.5	4.90	XUM-01-20
25	-0.030+0.010	28	57	5.0	0.8	4.0	8.23	XUM-01-25
30	-0.040+0.010	34	67	5.0	0.8	4.0	14.95	XUM-01-30
40	±0.000+0.050	44	79	6.0	1.3	5.0	23.16	XUM-01-40

Housing hole for XUM-01 | Dimensions [mm]

Shaft Ø	di	B	r	t	f	Z	Part No.
H7	h10	+0.05	+0.1	+0.5	+0.2		
12	14	32	3.0	1.0	1.5	3.1	XUM-01-12
14	16	30	3.5	1.0	1.7	3.6	XUM-01-14
16	18	36	3.5	1.0	1.7	3.6	XUM-01-16
20	23	45	5.0	1.0	2.0	3.6	XUM-01-20
25	28	58	5.0	1.0	2.0	4.1	XUM-01-25
30	34	68	5.0	1.0	2.0	4.1	XUM-01-30
40	44	80	6.0	1.5	2.5	5.1	XUM-01-40

Can be combined with:



RJUM-01-03
TJUM-01-03



RJUM-06-06-LL



FJUM-01-02

drylin® R liners | Product range

Long, open design for supported shafts, two-piece – made from iglidur® X (the extreme)

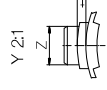
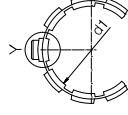
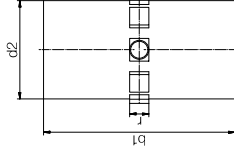

Type **iglidur® X** Size **Inner Ø d1**

Order key

XUM O-01-10

Standard
Open
Metric
Liner

The "extreme", resistant to temperature and chemicals on stainless steel and chromed shafts



⁷⁸⁾ According to iglus® testing method ▶ Page 1146

Please note: Installation instructions ▶ Page 1079



Min. -100°C

Max. +250°C

Dimensions [mm]

d1	d1 tolerance ⁷⁸⁾	d2	b1	r	t	Z	Weight [g]	Part No.
10	-0.020+0.020	12	28	3.0	0.8	2.5	1.00	XUMO-01-10 ¹⁰⁾
12	+0.020+0.060	14	31	3.0	0.8	3.0	1.20	XUMO-01-12
16	+0.020+0.060	18	35	3.5	0.8	3.5	2.30	XUMO-01-16
20	+0.030+0.070	23	44	5.0	0.8	3.5	4.30	XUMO-01-20
25	-0.030+0.010	28	57	5.0	0.8	4.0	6.80	XUMO-01-25
30	-0.040+0.010	34	67	5.0	0.8	4.0	13.30	XUMO-01-30
40	±0.000+0.050	44	79	6.0	1.3	5.0	22.60	XUMO-01-40

Housing hole for XUMO-01 | Dimensions [mm]

Shaft Ø	di	B	W	r	t	f	Z	Part No.
H7	h10	+0.2	+0.05	+0.1	+0.5	+0.2		
10	12	29	7.3	3.0	1.0	1.0	2.6	XUMO-01-10 ¹⁰⁾
12	14	32	9.0	3.0	1.0	1.5	3.1	XUMO-01-12
16	18	36	11.6	3.5	1.0	1.7	3.6	XUMO-01-16
20	23	45	12.0	5.0	1.0	2.0	3.6	XUMO-01-20
25	28	58	14.5	5.0	1.0	2.0	4.1	XUMO-01-25
30	34	68	16.6	5.0	1.0	2.0	4.1	XUMO-01-30
40	44	80	21.0	6.0	1.5	2.5	5.1	XUMO-01-40

¹⁰⁾ One-piece

Can be combined with:



OJUM-01-03
TJUM-01-03



OJUM-06-06-LL

Short, closed design for shafts, two-pieces –
made from iglidur® X (the extreme)

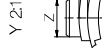
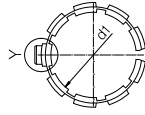
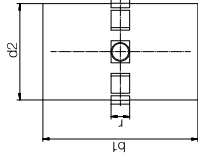

Order key

Type	Size
iglidur® X	Inner Ø d1
Liner	Compact
Metric	
XUM M-02-12	

The "extreme", resistant to temperature and
chemicals on stainless steel and chromed shafts



⁷⁸⁾ According to igus® testing method ▶ Page 1146

Please note: Installation instructions ▶ Page 1079



Min. -100°C

Max. +250°C

Dimensions [mm]

d1	d1 tolerance ⁷⁸⁾	d2	b1	r	t	Z	Weight [g]	Part No.
12	+0.020+0.060	14	27	3.0	0.8	3.0	1.3	XUM-02-12
16	+0.020+0.060	18	29	3.5	0.8	3.5	2.5	XUM-02-16
20	+0.030+0.070	23	29	5.0	0.8	3.5	3.4	XUM-02-20
25	-0.030+0.010	28	39	5.0	0.8	4.0	5.6	XUM-02-25
30	-0.040+0.010	34	49	5.0	0.8	4.0	12.0	XUM-02-30
40	±0.000+0.050	44	59	6.0	1.3	5.0	20.0	XUM-02-40

Housing hole for XUM-02 | Dimensions [mm]

Shaft Ø	di H7	B	b	r	t	f	Z	Part No.
12	14	28	3.0	1.0	1.5	+0.5	+0.2	XUM-02-12
16	18	30	3.5	1.0	1.7	3.6		XUM-02-16
20	23	30	5.0	1.0	2.0	3.6		XUM-02-20
25	28	40	5.0	1.0	2.0	4.1		XUM-02-25
30	34	50	5.0	1.0	2.0	4.1		XUM-02-30
40	44	60	6.0	1.5	2.5	5.1		XUM-02-40

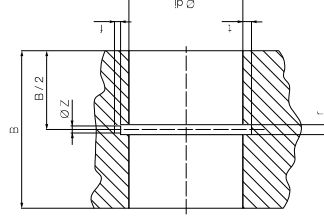

Can be combined with:



RJUM-02



RJUM-01-ES



RJUM-05/RJUME-05
TJUM-05/RJUMT-05



FJUMT-01-02

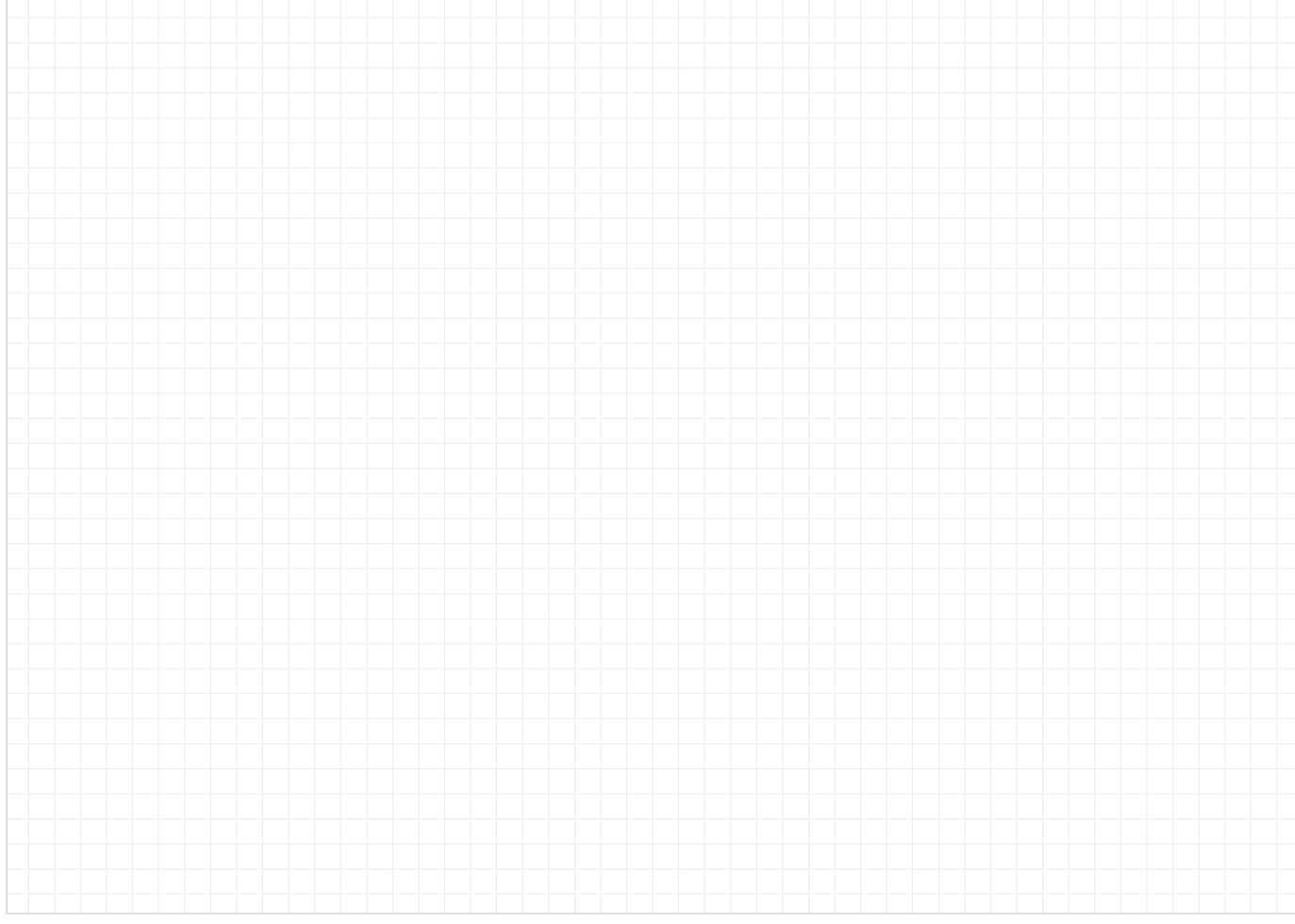

drylin® R liners | Product range

Long, closed design for round shafts –
made from iglidur® A180 (FDA-compliant)

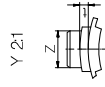
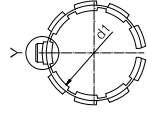
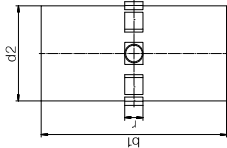

Order key

Type	Size
Liner	Standard
Metric	Standard
A180 U M-01-10	Inner Ø d1

The FDA-compliant for the food
and pharmaceutical industry

⁷⁸⁾ According to igus® testing method ▶ Page 1146
Please note: Installation instructions ▶ Page 1079

Min. -50°C
Max. +90°C

Dimensions [mm]

d1	d1 tolerance ⁷⁸⁾	d2	b1	r	t	Z	Weight [g]	Part No.
10	+0.000+0.020	12	28	3.0	0.8	2.5	1.08	A180UM-01-10
12	+0.030+0.070	14	31	3.0	0.8	3.0	1.47	A180UM-01-12
16	+0.030+0.070	18	35	3.5	0.8	3.5	2.16	A180UM-01-16
20	+0.030+0.070	23	44	5.0	0.8	3.5	4.80	A180UM-01-20
25	+0.030+0.070	28	57	5.0	0.8	4.0	8.07	A180UM-01-25
30	+0.040+0.085	34	67	5.0	0.8	4.0	14.65	A180UM-01-30
35	+0.040+0.085	39	69	5.0	0.8	4.0	17.84	A180UM-01-35
40	+0.040+0.085	44	79	6.0	1.3	5.0	22.70	A180UM-01-40
50	+0.050+0.150	55	99	7.0	1.3	6.0	44.44	A180UM-01-50

Housing hole for A180UM-01 | Dimensions [mm]

Shaft Ø	H7	B	h10	r	t	f	Z	Part No.
10	12	29	3.0	1.0	1.0	+0.5	+0.2	A180UM-01-10
12	14	32	3.0	1.0	1.5	3.1	3.1	A180UM-01-12
16	18	36	3.5	1.0	1.7	3.6	3.6	A180UM-01-16
20	23	45	5.0	1.0	2.0	3.6	3.6	A180UM-01-20
25	28	58	5.0	1.0	2.0	4.1	4.1	A180UM-01-25
30	34	68	5.0	1.0	2.0	4.1	4.1	A180UM-01-30
35	39	70	5.0	1.0	2.0	4.1	4.1	A180UM-01-35
40	44	80	6.0	1.5	2.5	5.1	5.1	A180UM-01-40
50	55	100	7.0	1.5	2.5	6.1	6.1	A180UM-01-50

Can be combined with:



RJUM-01-03
TJUM-01-03
FJUM-01-02

drylin® R liners | Product range

Long, open design for supported shafts –
made from iglidur® A180 (FDA-compliant)

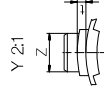
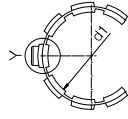
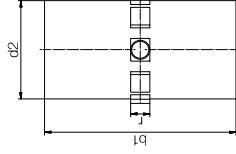

Order key

Type	Size
Liner	Standard
Metric	Standard
Open	Standard
A180 U M O-01-10	Inner Ø d1

The FDA-compliant for the food
and pharmaceutical industry

⁷⁸⁾ According to igus® testing method ▶ Page 1146
Please note: Installation instructions ▶ Page 1079

Min. -50°C
Max. +90°C

Dimensions [mm]

d1	d1 tolerance ⁷⁸⁾	d2	b1	r	t	Z	Weight [g]	Part No.
10	+0.000+0.020	12	28	3.0	0.8	2.5	1.08	A180UMO-01-10
12	+0.030+0.070	14	31	3.0	0.8	3.0	1.47	A180UMO-01-12
16	+0.030+0.070	18	35	3.5	0.8	3.5	2.16	A180UMO-01-16
20	+0.030+0.070	23	44	5.0	0.8	3.5	4.80	A180UMO-01-20
25	+0.030+0.070	28	57	5.0	0.8	4.0	8.07	A180UMO-01-25
30	+0.040+0.085	34	67	5.0	0.8	4.0	14.65	A180UMO-01-30
35	+0.040+0.085	39	69	5.0	0.8	4.0	17.84	A180UMO-01-40
40	+0.040+0.085	44	79	6.0	1.3	5.0	22.70	A180UMO-01-50

Housing hole for A180UMO-01 | Dimensions [mm]

Shaft Ø	H7	B	h10	r	t	f	Z	Part No.
10	12	29	3.0	1.0	1.0	+0.1	+0.2	A180UMO-01-10
12	14	32	3.0	1.0	1.5	3.1	3.1	A180UMO-01-12
16	18	36	3.5	1.0	1.7	3.6	3.6	A180UMO-01-16
20	23	45	5.0	1.0	2.0	3.6	3.6	A180UMO-01-20
25	28	58	5.0	1.0	2.0	4.1	4.1	A180UMO-01-25
30	34	68	5.0	1.0	2.0	4.1	4.1	A180UMO-01-30
40	44	80	6.0	1.5	2.5	5.1	5.1	A180UMO-01-40
50	55	100	7.0	1.5	2.5	6.1	6.1	A180UMO-01-50

Can be combined with:



OJUM-06-06-LL
TJUM-01-03

Long, closed design for round shafts – made from iglidur® A160 (compliant with Regulation (EU) No. 10/2011 and FDA guidelines)

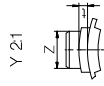
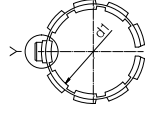
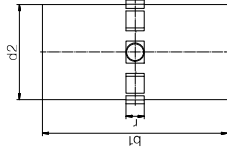

Order key

Type	Size
iglidur® A160	A160 U M-01-10
Liner	Metric
Standard	Inner Ø d1

Compliant with Regulation (EU) No. 10/2011 and FDA guidelines for longer service life on hardened stainless steel shafts



⁷⁸⁾ According to igus® testing method ▶ Page 1146
Please note: Installation instructions ▶ Page 1079

Min. -50°C
Max. +90°C

Dimensions [mm]

d1	d1 tolerance ⁷⁸⁾	d2	b1	r	t	Z	Weight [g]	Part No.
10	+0.03 +0.07	12	28	3.0	0.8	2.5	0.7	A160UM-01-10
12	+0.03 +0.07	14	31	3.0	0.8	3.0	1.0	A160UM-01-12
16	+0.03 +0.07	18	35	3.5	0.8	3.5	1.5	A160UM-01-16
20	+0.03 +0.07	23	44	5.0	0.8	3.5	3.3	A160UM-01-20
25	+0.03 +0.07	28	57	5.0	0.8	4.0	5.4	A160UM-01-25
30	+0.04 +0.09	34	67	5.0	0.8	4.0	9.9	A160UM-01-30
40	+0.04 +0.09	44	79	6.0	1.3	5.0	17.3	A160UM-01-40
50	+0.05 +0.15	55	99	7.0	1.3	6.0	36.3	A160UM-01-50

Housing hole for A160UM-01 | Dimensions [mm]

Shaft	d1	B	r	t	f	Z	Part No.
Ø	H7	h10	+0.05	+0.1	+0.5	+0.2	
10	12	29	3.0	1.0	1.0	2.6	A160UM-01-10
12	14	32	3.0	1.0	1.5	3.1	A160UM-01-12
16	18	36	3.5	1.0	1.7	3.6	A160UM-01-16
20	23	45	5.0	1.0	2.0	3.6	A160UM-01-20
25	28	58	5.0	1.0	2.0	4.1	A160UM-01-25
30	34	68	5.0	1.0	2.0	4.1	A160UM-01-30
40	44	80	6.0	1.5	2.5	5.1	A160UM-01-40
50	55	100	7.0	1.5	2.5	6.1	A160UM-01-50

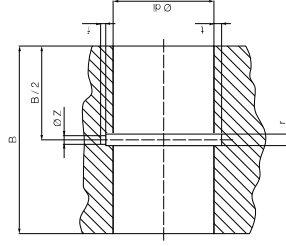

Can be combined with:



RJUM-01-03
TJUM-01-03
RJUM-06-06-LL
FJUM-01-02

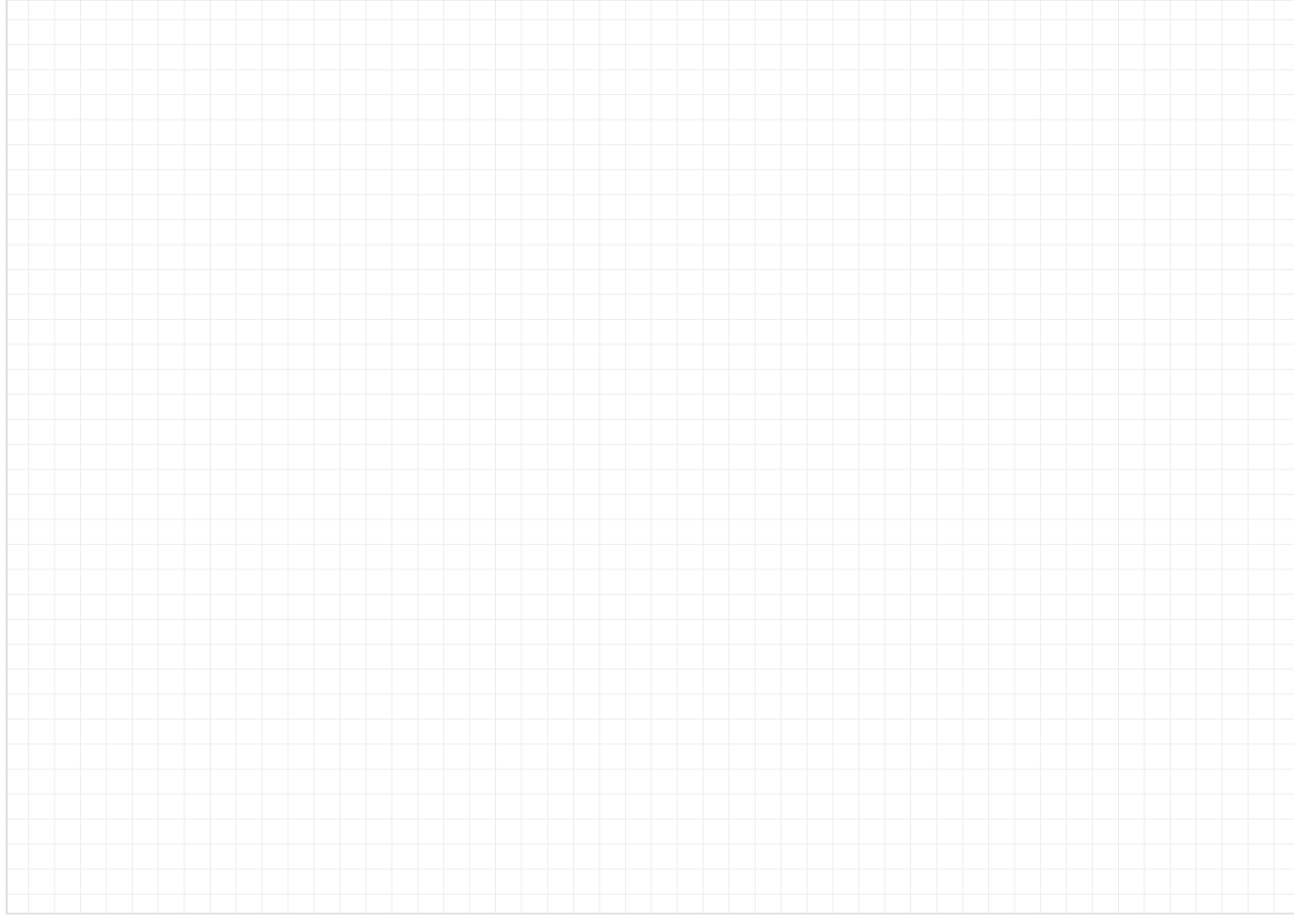

Large force displacement on different surfaces



Order key

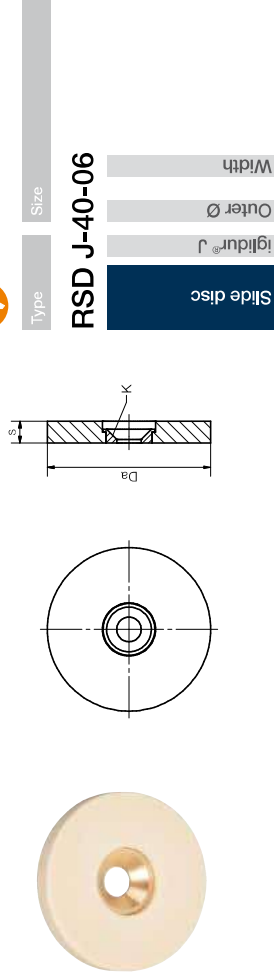

Type	Size	Width
Slide disc	RSD J-40-06	
		Outer Ø
		Width

- Made from the high-performance plastic iglidur® J
- Low coefficient of friction
- Screw through the reinforced hole in the middle for a firm hold

Min. -50°C
Max. +90°C

Dimensions [mm]

Outer Ø	Wear limit	Width	K	Max. static load capacity	Part No.
40	1,5	6 ± 0,05	M6	28,500	RSDJ-40-06
60	2,5	8 ± 0,05	M8	66,000	RSDJ-60-08
80	2,5	8 ± 0,05	M8	120,000	RSDJ-80-08

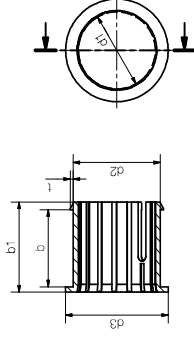

Order key

Type	Size	Length b
JUC M-1216-16		
		Outer Ø d2
		Inner Ø d1
		Metric
		Clip-on
		Liner

- Quick installation by hand for sheet thicknesses of 12 to 30mm
- No locating spigot required



⁷⁸⁾ According to igus® testing method ▶ Page 1146
⁸⁹⁾ Design tips ▶ Page 1078

Please note: Installation instructions ▶ Page 1079

Min. -50°C

Max. +90°C

Dimensions [mm]

d1	d2	d3	b	b1	t	Part No.
12	16	20	16	20,5	0,8	JUCM-1216-16
14	18	22	18	22,5	0,8	JUCM-1418-18
15	17	22	15	18,0	0,8	JUCM-1517-15 New
16	20	25	20	24,5	0,8	JUCM-1620-20
18	22	26	20	24,5	0,8	JUCM-1822-20
20	24	30	25	30,0	1,0	JUCM-2024-25
22	27	34	27	32,0	1,0	JUCM-2227-27
22	27	32	34	39,5	1,0	JUCM-2227-34
25	29	35	30	35,5	1,0	JUCM-2529-30
30	34	40	30	35,0	1,2	JUCM-3034-30

Technical data

Part No.	d1 tolerance ⁷⁸⁾		Fmax. dynamic ⁸²⁾		Fmax. static ⁸²⁾		Weight
	[mm]	p = 5MPa [N]	p = 5MPa [N]	p = 35MPa [N]	[g]		
JUCM-1216-16	+0,04 +0,10	320	1,600	1,600	2,5		
JUCM-1418-18	+0,04 +0,10	440	2,200	2,200	2,9		
JUCM-1517-15	+0,04 +0,10	380	1,900	1,900	1,4		
JUCM-1620-20	+0,04 +0,10	560	2,800	2,800	3,9		
JUCM-1822-20	+0,04 +0,10	630	3,150	3,150	4,2		
JUCM-2024-25	+0,04 +0,12	880	4,400	4,400	5,8		
JUCM-2227-27	+0,04 +0,12	1,000	5,000	5,000	9,4		
JUCM-2227-34	+0,04 +0,12	1,300	6,500	6,500	10,3		
JUCM-2529-30	+0,04 +0,12	1,300	6,500	6,500	8,6		
JUCM-3034-30	+0,04 +0,12	1,500	7,500	7,500	10,0		

Made from iglidur® L100



Order key



Type	Size
W L M-0608-10	
iglidur® L100	
L1 series	
Metric	
Inner Ø d1	
Outer Ø d2	
Length	

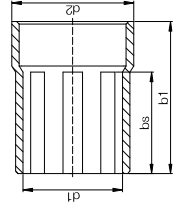
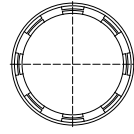

- Extreme wear resistance
- Low coefficient of friction

⁸⁰⁾ Measured with plug gauge

Please note: Installation instructions ▶ Page 1079

Material properties ▶ Page 1654

Min. -40°C

Max. +100°C



Dimensions [mm]

d1	d1 tolerance ⁸⁰⁾	d2	b1	bs	Part No.
6	+0.000 +0.040	8	10	6	WLM-0608-10
8	+0.000 +0.050	10	12	8	WLM-0810-12
10	+0.000 +0.050	12	14.5	10	WLM-1012-14
10	+0.000 +0.050	12	16	10	WLM-1012-16
12	+0.000 +0.050	14	16	10	WLM-1214-16
12	+0.000 +0.050	14	25	15	WLM-1214-25
16	+0.000 +0.050	18	18	10	WLM-1618-18
16	+0.000 +0.050	18	26	16	WLM-1618-26
20	+0.000 +0.060	23	22.5	12.5	WLM-2023-22
20	+0.000 +0.060	23	30	20	WLM-2023-30
22	+0.000 +0.060	25	30	20	WLM-2225-30
25	+0.000 +0.060	28	29	19	WLM-2528-29
25	+0.000 +0.060	28	35	25	WLM-2528-35
30	+0.000 +0.060	34	34	24	WLM-3034-34
30	+0.000 +0.060	34	40	30	WLM-3034-40
40	+0.000 +0.060	44	40	30	WLM-4044-40
40	+0.000 +0.060	44	50	40	WLM-4044-50
50	+0.000 +0.070	55	50	40	WLM-5055-50
50	+0.000 +0.070	55	60	50	WLM-5055-60

Made from iglidur® L100



Order key



Type	Size
W L F M-1214-15	
iglidur® L100	
L1 series	
With flange	
Metric	
Inner Ø d1	
Outer Ø d2	
Length	

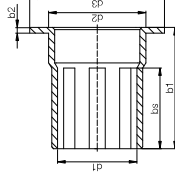
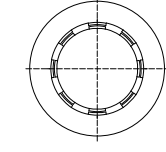

- Extreme wear resistance
- Low coefficient of friction

⁸⁰⁾ Measured with plug gauge

Please note: Installation instructions ▶ Page 1079

Material properties ▶ Page 1654

Min. -40°C

Max. +100°C



Dimensions [mm]

d1	d1 tolerance ⁸⁰⁾	d2	b1	bs	Part No.		
12	+0.000 +0.050	14	20	15.0	1.0	9	WLFM-1214-15
16	+0.000 +0.050	18	24	16.0	1.0	10	WLFM-1618-16
20	+0.000 +0.060	23	30	16.5	1.5	10	WLFM-2023-16
25	+0.000 +0.060	28	35	21.5	1.5	11	WLFM-2528-21
30	+0.000 +0.060	34	42	27.0	2.0	15	WLFM-3034-27
40	+0.000 +0.060	44	52	32.0	2.0	20	WLFM-4044-32
50	+0.000 +0.070	55	63	37.5	2.5	25	WLFM-5055-37

drylin® R solid plastic bearings | Product range

Standard design made from iglidur® J (the all-rounder)

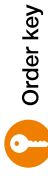

Order key



Type	Size
Closed	Inner Ø d1
Iglidur® J	
Metric	
Standard	

R J M-01-10

- Assembly by press-fitting
- Secured by circlips

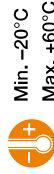

Min. -20°C
Max. +60°C

- i** ⁷⁸⁾ According to igus® testing method ▶ Page 1146
- ⁸²⁾ Design tips ▶ Page 1078
- ⁸³⁾ Applies by room temperature: press-fit decrease with time depending on the temperature

Please note: Installation instructions ▶ Page 1079

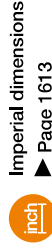

Imperial dimensions
▶ Page 1613

Dimensions [mm]

d1	d2	B	B1	s	dn	Part No.
8	16	25	16.2	1.10	15.2	RJM-01-08
10	19	29	21.6	1.30	17.5	RJM-01-10
12	22	32	22.6	1.30	20.5	RJM-01-12
16	26	36	24.6	1.30	24.2	RJM-01-16
20	32	45	31.2	1.60	29.6	RJM-01-20
25	40	58	43.7	1.85	36.5	RJM-01-25
30	47	68	51.7	1.85	43.5	RJM-01-30
40	62	80	60.3	2.15	57.8	RJM-01-40

Technical data

Part No.	d1 tolerance ⁷⁸⁾		Fmax. dynamic ⁸²⁾ p = 2.5MPa		Fmax. static ⁸²⁾ p = 17.5MPa		Weight [g]	Press-fit force ⁸³⁾ [N]
	[mm]	[mm]	[N]	[N]	[N]	[N]		
RJM-01-08	+0.025	+0.061	250	1,750	1,750	4	400	
RJM-01-10	+0.025	+0.061	363	2,538	2,538	7	700	
RJM-01-12	+0.032	+0.075	480	3,360	3,360	9	1,300	
RJM-01-16	+0.032	+0.075	720	5,040	5,040	13	1,100	
RJM-01-20	+0.040	+0.092	1,125	7,875	7,875	24	1,500	
RJM-01-25	+0.040	+0.092	1,813	12,688	12,688	47	3,500	
RJM-01-30	+0.040	+0.092	2,550	17,850	17,850	72	4,500	
RJM-01-40	+0.050	+0.112	4,000	28,000	28,000	127	4,200	

Can be combined with:

1102 Online tools and more information ▶ www.igus-asean.com/drylinR

Type	Size
Closed	Inner Ø d1
Iglidur® J	
Metric	
Precise	
Standard	

R J M P-01-10

- Easy assembly by soft press-fit
- Reduced bearing clearance
- Secured by circlips



⁷⁸⁾ According to igus® testing method ▶ Page 1146

⁸²⁾ Design tips ▶ Page 1078

Please note: Installation instructions ▶ Page 1079



Min. -20°C
Max. +60°C



Imperial dimensions
▶ Page 1613

Dimensions [mm]

d1	d2	B	B1	s	dn	Part No.
6	12	19	13.5	1.10	11.5	RJMP-01-06
8	16	25	16.2	1.10	15.2	RJMP-01-08
10	19	29	21.6	1.30	17.5	RJMP-01-10
12	22	32	22.6	1.30	20.5	RJMP-01-12
16	26	36	24.6	1.30	24.2	RJMP-01-16
20	32	45	31.2	1.60	29.6	RJMP-01-20
25	40	58	43.7	1.85	36.5	RJMP-01-25
30	47	68	51.7	1.85	43.5	RJMP-01-30

Technical data

Part No.	d1 tolerance ⁷⁸⁾		Fmax. dynamic ⁸²⁾ p = 2.5MPa		Fmax. static ⁸²⁾ p = 17.5MPa		Weight [g]
	[mm]	[mm]	[N]	[N]	[N]	[g]	
RJMP-01-06	+0.000	+0.030	200	1,400	1,400	2	
RJMP-01-08	+0.000	+0.040	250	1,750	1,750	4	
RJMP-01-10	+0.000	+0.040	363	2,538	2,538	7	
RJMP-01-12	+0.000	+0.040	480	3,360	3,360	9	
RJMP-01-16	+0.000	+0.040	720	5,040	5,040	13	
RJMP-01-20	+0.000	+0.040	1,125	7,875	7,875	24	
RJMP-01-25	+0.000	+0.050	1,813	12,688	12,688	47	
RJMP-01-30	+0.000	+0.050	2,550	17,850	17,850	72	

Can be combined with:

3D CAD files, prices and delivery time online ▶ www.igus-asean.com/drylinR 1103

drylin® R solid plastic bearings | Product range

Linear plain bearings with Japanese dimensions made from iglidur® J4



Order key

Type	Size
iglidur® J4	Japan standard
Closed	Precise
	Standard
	Inner Ø d1

R J 4 J P-01-10

- Alternative to ball bearings with Japanese dimension
- Quickly assembled
- Secured by circlips

⁷⁸⁾ According to iglus® testing method ▶ Page 1146⁸²⁾ Design tips ▶ Page 1078

Please note: Installation instructions ▶ Page 1079

Material properties ▶ Page 1652



Min. -20°C

Max. +60°C

Dimensions [mm]

d1	d2	B	B1	s	dn	Part No.
8	15	24	17.5	1.1	14.3	RJ4JP-01-08
10	19	29	22.0	1.3	18.0	RJ4JP-01-10
12	21	30	23.0	1.3	20.0	RJ4JP-01-12
16	28	37	26.5	1.6	26.6	RJ4JP-01-16
20	32	42	30.5	1.6	30.3	RJ4JP-01-20
25	40	59	41.1	1.85	37.5	RJ4JP-01-25
30	45	64	44.6	1.85	42.5	RJ4JP-01-30

Technical data

Part No.	d1 tolerance ⁷⁹⁾		Fmax. dynamic ⁸²⁾		Fmax. static ⁸²⁾		Weight
	[mm]	[N]	[N]	[N]	[N]	[g]	
RJ4JP-01-08	+0.000 +0.040	200	800	800	2	2	
RJ4JP-01-10	+0.000 +0.040	300	1,200	1,200	6	6	
RJ4JP-01-12	+0.000 +0.040	400	1,600	1,600	8	8	
RJ4JP-01-16	+0.000 +0.040	700	2,800	2,800	16	16	
RJ4JP-01-20	+0.000 +0.040	1,000	4,000	4,000	23	23	
RJ4JP-01-25	+0.000 +0.050	1,550	6,500	6,500	47	47	
RJ4JP-01-30	+0.000 +0.050	2,200	8,500	8,500	72	72	

drylin® R solid plastic bearings | Product range

Low-cost linear plain bearings made from iglidur® J260



Order key

Type	Size
iglidur® J260	Grooved
Closed	Metric
	Compact
	Inner Ø d1

R J260 U M-02-12

- 2 variations: RJ260M (with plain design) and RJ260UM (grooved structure)

⁷⁸⁾ According to iglus® testing method ▶ Page 1146⁸²⁾ Design tips ▶ Page 1078

Please note: Installation instructions ▶ Page 1079



Min. -20°C

Max. +60°C

Dimensions [mm]

d1	d2	B	C	Part No.
12	19	28	1,5x15°	RJ260UM-02-12
16	24	30	1,5x15°	RJ260UM-02-16
20	28	30	2,0x15°	RJ260UM-02-20
25	35	40	2,0x15°	RJ260UM-02-25

Technical data

Part No.	d1 tolerance ⁷⁹⁾		Fmax. dynamic ⁸²⁾		Fmax. static ⁸²⁾		Weight
	[mm]	[N]	[N]	[N]	[g]		
RJ260UM-02-12	+0.035 +0.080	420	2,940	2,940	6.2		
RJ260UM-02-16	+0.035 +0.080	600	4,200	4,200	9.7		
RJ260UM-02-20	+0.040 +0.095	750	5,250	5,250	11.7		
RJ260UM-02-25	+0.040 +0.095	1,250	8,750	8,750	22.8		

Closed, anodised aluminium adapter



Order key

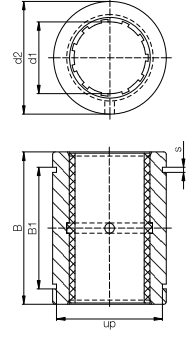

Type	Size
Closed	Inner Ø d1
igidur® J	
Liner	
Metric	
Standard	

RJUM-01-10

- Secured by circlips

i ⁷⁸⁾ According to igus® testing method ▶ Page 1146

⁸¹⁾ Ø < 10mm use press-fitted sleeve plain bearings

⁸²⁾ Design tips ▶ Page 1078

Please note: Installation instructions ▶ Page 1079

Dimensions [mm]

d1	d2	B	B1	s	dn	Part No.
H7	H7	h10	H10	H10	h10	
5	12	22	14,2	1,10	11,5	RJZM-01-05 ⁸¹⁾
6	12	22	14,2	1,10	11,5	RJZM-01-06 ⁸¹⁾
8	16	25	16,2	1,10	15,2	RJZM-01-08 ⁸¹⁾
10	19	29	21,6	1,30	17,5	RJUM-01-10
12	22	32	22,6	1,30	20,5	RJUM-01-12
16	26	36	24,6	1,30	24,2	RJUM-01-16
20	32	45	31,2	1,60	29,6	RJUM-01-20
25	40	58	43,7	1,85	36,5	RJUM-01-25
30	47	68	51,7	1,85	43,5	RJUM-01-30
40	62	80	60,3	2,15	57,8	RJUM-01-40
50	75	100	77,3	2,65	70,5	RJUM-01-50
60	90	125	101,7	3,15	86,5	RJUM-01-60

Technical data

Part No.	d1 tolerance ⁷⁸⁾ [mm]	Fmax. dynamic ⁸²⁾ p = 5MPa		Fmax. static ⁸²⁾ p = 35MPa		Weight [g]
		[N]	[lbf]	[N]	[lbf]	
RJZM-01-05 ⁸¹⁾	+0,025 +0,060	525	118	3,675	825	5
RJZM-01-06 ⁸¹⁾	+0,025 +0,060	525	118	3,675	825	5
RJZM-01-08 ⁸¹⁾	+0,032 +0,070	960	215	6,720	1,500	9
RJUM-01-10	+0,030 +0,068	725	163	5,075	1,140	14
RJUM-01-12	+0,030 +0,068	960	215	6,720	1,500	21
RJUM-01-16	+0,030 +0,068	1,440	324	10,080	2,270	28
RJUM-01-20	+0,030 +0,091	2,250	506	15,750	3,530	49
RJUM-01-25	+0,030 +0,091	3,625	813	25,375	5,700	108
RJUM-01-30	+0,040 +0,110	5,100	1,145	35,700	8,000	162
RJUM-01-40	+0,040 +0,115	8,000	1,800	56,000	12,400	334
RJUM-01-50	+0,050 +0,130	9,000	2,025	63,000	14,000	579
RJUM-01-60	+0,050 +0,140	12,000	2,700	84,000	18,700	1,070

Closed, anodised aluminium adapter, precise



Order key

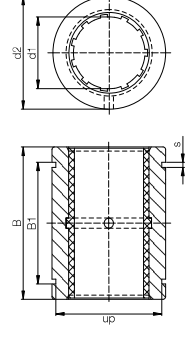

Type	Size
Closed	Inner Ø d1
igidur® J	
Liner	
Metric	
Precise	

RJUM-11-10

- Max. bearing clearance reduced by 50%



⁷⁸⁾ According to igus® testing method ▶ Page 1146

⁸²⁾ Design tips ▶ Page 1078

Please note: Installation instructions ▶ Page 1079

Dimensions [mm]

d1	d2	B	B1	s	dn	Part No.
H7	H7	h10	H10	H10	h10	
10	19	29	21,6	1,30	17,5	RJUM-11-10
12	22	32	22,6	1,30	20,5	RJUM-11-12
16	26	36	24,6	1,30	24,2	RJUM-11-16
20	32	45	31,2	1,60	29,6	RJUM-11-20
25	40	58	43,7	1,85	36,5	RJUM-11-25
30	47	68	51,7	1,85	43,5	RJUM-11-30
40	62	80	60,3	2,15	57,8	RJUM-11-40
50	75	100	77,3	2,65	70,5	RJUM-11-50

Technical data

Part No.	d1 tolerance ⁷⁸⁾ [mm]	Fmax. dynamic ⁸²⁾ p = 5MPa		Fmax. static ⁸²⁾ p = 35MPa		Weight [g]
		[N]	[lbf]	[N]	[lbf]	
RJUM-11-10	+0,000 +0,058	725	163	5,075	1,140	14
RJUM-11-12	+0,000 +0,058	960	215	6,720	1,500	21
RJUM-11-16	+0,000 +0,058	1,440	324	10,080	2,270	28
RJUM-11-20	+0,000 +0,061	2,250	506	15,750	3,530	49
RJUM-11-25	+0,000 +0,061	3,625	813	25,375	5,700	108
RJUM-11-30	+0,000 +0,075	5,100	1,145	35,700	8,000	162
RJUM-11-40	+0,000 +0,080	8,000	1,800	56,000	12,400	334
RJUM-11-50	+0,000 +0,090	12,500	2,790	87,500	19,500	579

Can be combined with:



Available with drylin® liners (optional: J200/A180):

Closed stainless steel adapter made of stainless steel 303



Order key

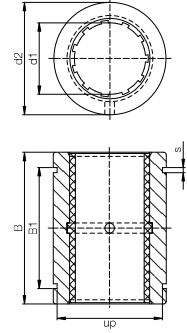

Type	Size	Material
Closed	Inner Ø d1	Stainless steel
Liner	Standard	
Metric		

R J U M-01-12-ES

- Secured by circlips

⁷⁸⁾ According to igus® testing method ▶ Page 1146⁸²⁾ Design tips ▶ Page 1078

Please note: Installation instructions ▶ Page 1079

Dimensions [mm]

d1	d2	B	B1	s	dh	Part No.
H7	H10	h10	H10	H10	h10	
12	22	32	22,6	1,30	20,5	RJUM-01-12-ES
16	26	36	24,6	1,30	24,2	RJUM-01-16-ES
20	32	45	31,2	1,60	29,6	RJUM-01-20-ES
25	40	58	43,7	1,85	36,5	RJUM-01-25-ES
30	47	68	51,7	1,85	43,5	RJUM-01-30-ES

Technical data

Part No.	d1 tolerance ⁷⁸⁾		Fmax. dynamic ⁸²⁾ p = 5MPa		Fmax. static ⁸²⁾ p = 35MPa		Weight
	[mm]	[N]	[N]	[g]			
RJUM-01-12-ES	+0,030 +0,088	960	6,720	60			
RJUM-01-16-ES	+0,030 +0,088	1,440	10,080	84			
RJUM-01-20-ES	+0,030 +0,091	2,250	15,750	147			
RJUM-01-25-ES	+0,030 +0,091	3,625	25,375	324			
RJUM-01-30-ES	+0,040 +0,110	5,100	35,700	486			

Available with drylin® liners (optional: J200/A180):



Closed, anodised aluminium adapter, short design



Order key

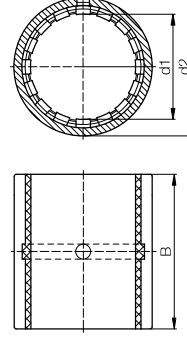

Type	Size
Closed	Inner Ø d1
Liner	Metric
Metric	Compact

R J U M-02-10

- Also available as a reduced clearance version RJUM-12 (Ø 10–50mm)

⁷⁸⁾ According to igus® testing method ▶ Page 1146⁸¹⁾ Ø < 10mm use press-fitted sleeve bearings⁸²⁾ Design tips ▶ Page 1078

Please note: Installation instructions ▶ Page 1079

Dimensions [mm]

d1	d2	B	Part No.
H7	h10	h10	
6	12	22	RJZM-02-06 ⁸¹⁾
8	15	24	RJZM-02-08 ⁸¹⁾
10	17	26	RJUM-02-10
12	19	28	RJUM-02-12
16	24	30	RJUM-02-16
20	28	30	RJUM-02-20
25	35	40	RJUM-02-25
30	40	50	RJUM-02-30
40	52	60	RJUM-02-40
50	62	70	RJUM-02-50

Technical data

Part No.	Housing hole		d1 tolerance ⁷⁸⁾		Fmax. dynamic ⁸²⁾ p = 5MPa		Fmax. static ⁸²⁾ p = 35MPa		Weight
	Ø H7 [mm]	[mm]	[mm]	[N]	[N]	[g]			
RJZM-02-06 ⁸¹⁾	12	+0,032 +0,070	600	4,200	4				
RJZM-02-08 ⁸¹⁾	15	+0,032 +0,070	650	4,550	6				
RJUM-02-10	17	+0,030 +0,088	650	4,550	8				
RJUM-02-12	19	+0,030 +0,088	840	5,880	10				
RJUM-02-16	24	+0,030 +0,088	1,200	8,400	17				
RJUM-02-20	28	+0,030 +0,091	1,500	10,500	18				
RJUM-02-25	35	+0,030 +0,091	2,500	17,500	42				
RJUM-02-30	40	+0,040 +0,110	3,750	26,250	56				
RJUM-02-40	52	+0,040 +0,115	6,000	42,000	113				
RJUM-02-50	62	+0,050 +0,130	8,750	61,250	147				

drylin® R linear plain bearings | Product range

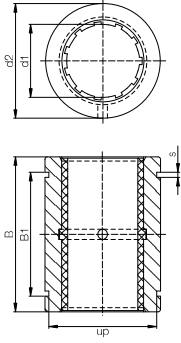
Closed, anodised aluminium adapters
with iglidur® E7 liner

Type	Size
iglidur® E7	Standard
Liner	Metric
Closed	Inner Ø d1

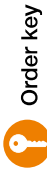

Order key

- Secured by circlips

i ⁷⁸⁾ According to iglus® testing method ▶ Page 1146
⁸²⁾ Design tips ▶ Page 1078

Please note: Installation instructions ▶ Page 1079

Dimensions [mm]

d1	d2	B	B1	s	dn	Part No.
H7	h10	h10	H10	H10	h10	
10	19	29	21,6	1,30	17,5	RE7UM-01-10
12	22	32	22,6	1,30	20,5	RE7UM-01-12
16	26	36	24,6	1,30	24,2	RE7UM-01-16
20	32	45	31,2	1,60	29,6	RE7UM-01-20
25	40	58	43,7	1,85	36,5	RE7UM-01-25
30	47	68	51,7	1,85	43,5	RE7UM-01-30
40	62	80	60,3	2,15	57,8	RE7UM-01-40
50	75	100	77,3	2,65	70,5	RE7UM-01-50
60	90	125	101,7	3,15	86,5	RE7UM-01-60

Technical data

Part No.	d1 tolerance ⁷⁹⁾		F max. dynamic ⁸²⁾		F max. static ⁸²⁾		Weight
	[mm]	[N]	p = 2,5MPa	p = 18MPa	[N]	[g]	
RE7UM-01-10	+0,030 +0,088	360	480	2,610	14	1,4	
RE7UM-01-12	+0,030 +0,088	480	720	3,450	21	2,1	
RE7UM-01-16	+0,030 +0,088	720	1,120	5,180	28	2,8	
RE7UM-01-20	+0,030 +0,091	1,120	1,810	8,100	49	4,9	
RE7UM-01-25	+0,030 +0,091	1,810	2,550	13,050	108	10,8	
RE7UM-01-30	+0,040 +0,110	2,550	4,000	18,360	162	16,2	
RE7UM-01-40	+0,040 +0,115	4,000	4,500	28,800	334	33,4	
RE7UM-01-50	+0,050 +0,180	4,500	6,000	45,000	579	57,9	
RE7UM-01-60	+0,050 +0,190	6,000		61,700	1,070	107,0	

drylin® R linear plain bearings | Product range

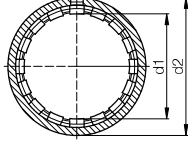
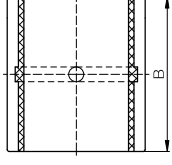
Closed, anodised aluminium adapters,
short design
with iglidur® E7 liner

Type	Size
iglidur® E7	Compact
Liner	Metric
Closed	Inner Ø d1



Order key

i ⁷⁸⁾ According to iglus® testing method ▶ Page 1146
⁸²⁾ Design tips ▶ Page 1078

Please note: Installation instructions ▶ Page 1079

Dimensions [mm]

d1	d2	B	Part No.
H7	h10	h10	
10	17	26	RE7UM-02-10
12	19	28	RE7UM-02-12
16	24	30	RE7UM-02-16
20	28	30	RE7UM-02-20
25	35	40	RE7UM-02-25
30	40	50	RE7UM-02-30
40	52	60	RE7UM-02-40
50	62	70	RE7UM-02-50

Technical data

Part No.	Housing hole		F max. dynamic ⁸²⁾		F max. static ⁸²⁾		Weight
	Ø H7 [mm]	[mm]	p = 2,5MPa	p = 18MPa	[N]	[g]	
RE7UM-02-10	17	+0,030 +0,088	325	2,340	8	0,8	
RE7UM-02-12	19	+0,030 +0,088	420	3,020	10	1,0	
RE7UM-02-16	24	+0,030 +0,088	600	4,320	17	1,7	
RE7UM-02-20	28	+0,030 +0,091	750	5,400	18	1,8	
RE7UM-02-25	35	+0,030 +0,091	1,250	9,000	42	4,2	
RE7UM-02-30	40	+0,040 +0,110	1,875	13,500	56	5,6	
RE7UM-02-40	52	+0,040 +0,115	3,000	21,600	113	11,3	
RE7UM-02-50	62	+0,050 +0,180	4,375	31,500	147	14,7	

drylin® R linear plain bearings | Product range
Closed aluminium adapter (floating bearing)

Order key

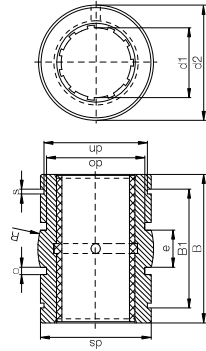

Type	Size
Open	Inner Ø d1
Liner	
Metric	
Self-aligning	
Closed	

R J U M-03-10

- With reduced outer diameter, spherical area on the outer diameter, O-rings for elastic seating and hard-anodised surface

⁷⁸⁾ According to igus® testing method ▶ Page 1146⁸¹⁾ Ø < 10mm use press-fitted sleeve plain bearings⁸²⁾ Design tips ▶ Page 1078

Please note: Installation instructions ▶ Page 1079

Floating bearing ▶ Page 1078

Imperial dimensions ▶ Page 1615



Dimensions [mm]

d1	d2 H7	B h10	B1 H10	s H10	dn h10	ds h10	do +0.1	e	R	Part No.
8	15.8	24.9	16.4	1.10	15.0	15.5	13.2	1.86	5.0	20.0 RJZM-03-08 ⁸¹⁾
10	18.8	28.9	21.8	1.30	17.5	18.5	15.4	1.86	5.0	13.0 RJUM-03-10
12	21.8	31.9	22.8	1.30	20.5	21.5	18.4	1.86	6.0	18.0 RJUM-03-12
16	25.8	35.9	24.9	1.30	24.2	25.5	20.4	2.86	8.0	32.0 RJUM-03-16
20	31.8	44.8	31.5	1.60	29.6	31.5	26.4	2.86	10.0	50.0 RJUM-03-20
25	39.8	57.8	44.1	1.85	36.5	39.0	34.4	2.86	12.5	39.0 RJUM-03-25
30	46.7	67.8	52.1	1.85	43.5	46.0	41.4	2.86	15.0	57.0 RJUM-03-30
40	61.7	79.8	60.9	2.15	57.8	61.0	56.4	2.86	20.0	100.0 RJUM-03-40
50	74.7	99.8	78.0	2.65	70.5	74.0	69.4	2.86	25.0	157.0 RJUM-03-50

Technical data

Part No.	Housing hole Ø H7 [mm]	F max. dynamic ⁸²⁾		F max. static ⁸²⁾		Weight [g]
		[N]	[N]	[N]	[N]	
RJZM-03-08 ⁸¹⁾	16	+0.032	+0.070	960	6,720	8
RJUM-03-10	19	+0.030	+0.088	725	5,075	11
RJUM-03-12	22	+0.030	+0.088	960	6,720	17
RJUM-03-16	26	+0.030	+0.088	1,440	10,080	23
RJUM-03-20	32	+0.030	+0.091	2,250	15,750	44
RJUM-03-25	40	+0.030	+0.091	3,625	25,375	92
RJUM-03-30	47	+0.040	+0.110	5,100	35,700	145
RJUM-03-40	62	+0.040	+0.115	8,000	56,000	311
RJUM-03-50	75	+0.050	+0.150	12,500	87,500	542

Can be combined with:



Available with drylin® liners (optional: J200/A180):

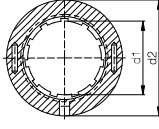
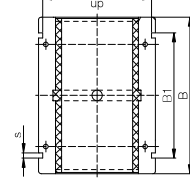
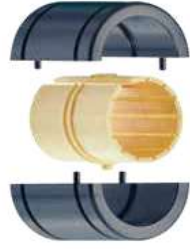
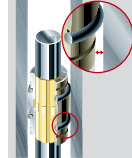

Type	Size
Open	Inner Ø d1
Liner	
Metric	
Standard	
J	
T J U M-01-10	



Order key

drylin® R linear plain bearings | Product range
Split anodised aluminium adapter

- Quick replacement of the liner without removing the shaft

⁷⁸⁾ According to igus® testing method ▶ Page 1146⁸²⁾ Design tips ▶ Page 1078

Please note: Installation instructions ▶ Page 1079

Imperial dimensions ▶ Page 1616



Dimensions [mm]

d1	d2 H7	B h10	B1 H10	s H10	dn h10	ds h10	do +0.1	e	R	Part No.
10	19	-0.020	-0.040	29	21.6	1.30	17.5	1.30	17.5	TJUM-01-10
12	22	-0.020	-0.040	32	22.6	1.30	20.5	1.30	20.5	TJUM-01-12
16	26	-0.020	-0.040	36	24.6	1.30	24.2	1.30	24.2	TJUM-01-16
20	32	-0.020	-0.045	45	31.2	1.60	29.6	1.85	29.6	TJUM-01-20
25	40	-0.030	-0.055	58	43.7	1.85	36.5	2.15	36.5	TJUM-01-25
30	47	-0.030	-0.055	68	51.7	1.85	43.5	2.15	43.5	TJUM-01-30
40	62	-0.030	-0.060	80	60.3	2.15	57.8	2.65	57.8	TJUM-01-40
50	75	-0.030	-0.060	100	77.3	2.65	70.5	2.65	70.5	TJUM-01-50

Technical data

Part No.	d1 tolerance ⁷⁸⁾		F max. dynamic ⁸²⁾		F max. static ⁸²⁾		Weight [g]
	[mm]	p = 5MPa	[N]	[N]	[N]	p = 35MPa	
TJUM-01-10	+0.030	+0.092	725	5,075	14	14	
TJUM-01-12	+0.030	+0.097	960	6,720	19	19	
TJUM-01-16	+0.030	+0.097	1,440	10,080	27	27	
TJUM-01-20	+0.030	+0.103	2,250	15,750	49	49	
TJUM-01-25	+0.030	+0.103	3,625	25,375	106	106	
TJUM-01-30	+0.040	+0.124	5,100	35,700	166	166	
TJUM-01-40	+0.040	+0.124	8,000	56,000	347	347	
TJUM-01-50	+0.050	+0.196	12,500	87,500	577	577	

Can be combined with:



Available with drylin® liners (optional: J200/A180):

drylin® R linear plain bearings | Product range

Split aluminium adapter (floating bearing)



Order key

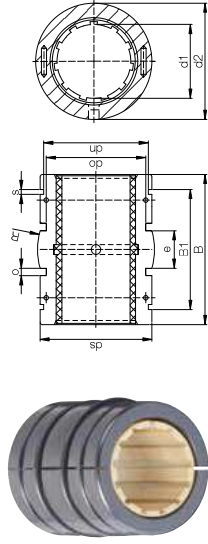

Type	Size
Open	Inner Ø d1
igitur® J	
Liner	
Metric	
Self-aligning	

T J U M-03-10

- Split aluminium adapter with spherical middle area for automatic compensation of misalignments and O-rings for elastic seating



⁷⁸⁾ According to igus® testing method ▶ Page 1146

⁸²⁾ Design tips ▶ Page 1078

Please note: Installation instructions ▶ Page 1079

Floating bearing ▶ Page 1078

Imperial dimensions ▶ Page 1616



Dimensions [mm]

d1	d2	B	B1	s	dn	h10	ds	do	o	e	R	Part No.
10	19	-0,020-0,040	28,9	21,8	1,30	17,5	18,5	15,4	1,86	5,0	13,0	TJUM-03-10
12	22	-0,020-0,040	31,9	22,8	1,30	20,5	21,5	18,4	1,86	6,0	18,0	TJUM-03-12
16	26	-0,020-0,040	35,9	24,9	1,30	24,2	25,5	20,4	2,86	8,0	32,0	TJUM-03-16
20	32	-0,020-0,045	44,8	31,5	1,60	29,6	31,5	26,4	2,86	10,0	50,0	TJUM-03-20
25	40	-0,030-0,055	57,8	44,1	1,85	36,5	39,0	34,4	2,86	12,5	39,0	TJUM-03-25
30	47	-0,030-0,055	67,8	52,1	1,85	43,5	46,0	41,4	2,86	15,0	57,0	TJUM-03-30
40	62	-0,030-0,060	79,8	60,9	2,15	57,8	61,0	56,4	2,86	20,0	100,0	TJUM-03-40
50	75	-0,030-0,060	99,8	78,0	2,65	70,5	74,0	69,4	2,86	25,0	157,0	TJUM-03-50

Technical data

Part No.	d1 tolerance ⁷⁸⁾ [mm]	Fmax. dynamic ⁸²⁾ p = 5MPa		Fmax. static ⁸²⁾ p = 35MPa		Weight [g]
		[N]	[N]	[N]	[N]	
TJUM-03-10	+0,030 +0,092	725	725	5,075	5,075	11
TJUM-03-12	+0,030 +0,097	960	960	6,720	6,720	17
TJUM-03-16	+0,030 +0,097	1,440	1,440	10,080	10,080	23
TJUM-03-20	+0,030 +0,103	2,250	2,250	15,750	15,750	44
TJUM-03-25	+0,030 +0,103	3,625	3,625	25,375	25,375	92
TJUM-03-30	+0,040 +0,124	5,100	5,100	35,700	35,700	145
TJUM-03-40	+0,040 +0,124	8,000	8,000	56,000	56,000	311
TJUM-03-50	+0,050 +0,196	12,500	12,500	87,500	87,500	542

Can be combined with:



Available with drylin® liners (optional: J200/A180):

drylin® R linear plain bearings | Product range

Open, anodised aluminium adapters – for supported shafts



Order key

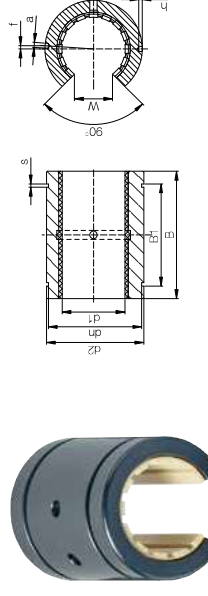

Type	Size
Open	Inner Ø d1
igitur® J	
Liner	
Metric	
Standard	

O J U M-01-10

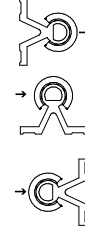

⁷⁸⁾ According to igus® testing method ▶ Page 1146

⁸²⁾ Design tips ▶ Page 1078

Please note: Installation instructions ▶ Page 1079

Imperial dimensions ▶ Page 1614



Dimensions [mm]

d1	d2	B	W	a	dh	B1	s	f	h	Part No.
10	19	29	7,3	0,0	17,5	21,6	1,30	0	1,2	OJUM-01-10
12	22	32	9,0	3,0	20,5	22,6	1,30	1,33 (7°)	1,2	OJUM-01-12
16	26	36	11,6	2,2	24,2	24,6	1,30	0	1,2	OJUM-01-16
20	32	45	12,0	2,2	29,6	31,2	1,60	0	1,2	OJUM-01-20
25	40	58	14,5	3,0	36,5	43,7	1,85	-1,5 (-4,3°)	1,5	OJUM-01-25
30	47	68	16,6	3,0	43,5	51,7	1,85	2 (4,9°)	2,0	OJUM-01-30
40	62	80	21,0	3,0	57,8	60,3	2,15	1,5 (2,8°)	2,0	OJUM-01-40
50	75	100	25,5	5,0	70,5	77,3	2,65	2,5 (3,8°)	2,0	OJUM-01-50

Technical data

Part No.	d1 tolerance ⁷⁸⁾	Fmax. dynamic ⁸²⁾ p = 5MPa			Fmax. static ⁸²⁾ p = 35MPa			Weight [g]
		0°	90°	180°	0°	90°	180°	
OJUM-01-10	+0,030 +0,088	725	500	196	5,075	3,500	1,370	11
OJUM-01-12	+0,030 +0,088	960	635	240	6,720	4,445	1,680	15
OJUM-01-16	+0,030 +0,088	1,440	930	396	10,080	6,943	2,772	21
OJUM-01-20	+0,030 +0,091	2,250	1,800	900	15,750	12,600	6,300	42
OJUM-01-25	+0,030 +0,091	3,625	2,963	1,523	25,375	20,670	10,658	70
OJUM-01-30	+0,040 +0,110	5,100	4,250	2,278	35,700	29,735	15,946	132
OJUM-01-40	+0,040 +0,115	8,000	6,810	3,800	56,000	47,660	26,660	278
OJUM-01-50	+0,050 +0,150	12,500	10,750	6,125	87,500	75,265	42,875	479

Can be combined with:



Available with drylin® liners (optional: J200/A180):

drylin® R linear plain bearings | Product range

Open, anodised aluminium adapter, floating bearing

My sketches

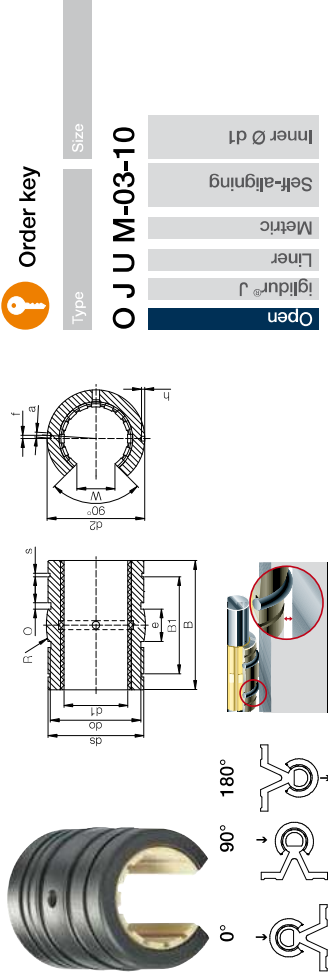

- With reduced outer diameter, spherical area on the outer diameter, O-rings for elastic seating and hard-anodised surface

- i** ⁷⁸⁾ According to igus® testing method ▶ Page 1146
- i** ⁸²⁾ Design tips ▶ Page 1078
- Please note: Installation instructions ▶ Page 1079
- inch** Imperial dimensions ▶ Page 1614

Dimensions [mm]

d1	d2	ds	e	o	do	B1	s	B	R	W	a	f	h	Part No.
H7	h10	+0.1	1.86	15.4	21.8	1.30	28.9	13.0	7.3	0.0	0	±0.2	-0.5	
10	18.8	18.5	5.0	1.86	15.4	1.30	28.9	13.0	7.3	0.0	0	±0.2	-0.5	OJUM-03-10
12	21.8	21.5	6.0	1.86	18.4	2.28	31.9	18.0	9.0	3.0	1.33 (7°)	1.2	1.2	OJUM-03-12
16	25.8	25.5	8.0	2.86	20.4	2.49	35.9	32.0	11.6	2.2	0	1.2	1.2	OJUM-03-16
20	31.8	31.5	10.0	2.86	26.4	31.5	44.8	50.0	12.0	2.2	0	1.2	1.2	OJUM-03-20
25	39.8	39.0	12.5	2.86	34.4	44.1	57.8	67.8	14.5	3.0	-1.5 (-4.3°)	1.5	1.5	OJUM-03-25
30	46.7	46.0	15.0	2.86	41.4	52.1	67.8	79.8	16.6	3.0	2 (4.9°)	2	2	OJUM-03-30
40	61.7	61.0	20.0	2.86	56.4	60.9	81.8	100.0	21.0	3.0	1.5 (2.8°)	2	2	OJUM-03-40
50	74.7	74.0	25.0	2.86	69.4	78.0	99.8	117.0	25.5	5.0	2.5 (3.8°)	2	2	OJUM-03-50

Technical data

Part No.	Housing hole Ø H7 [mm]	Fmax. dynamic ⁸²⁾ p = 5MPa			Fmax. static ⁸²⁾ p = 35MPa			Weight [g]		
		0°	90°	180°	0°	90°	180°			
OJUM-03-10	19	+0.030	+0.088	725	500	196	5,075	3,500	1,370	10
OJUM-03-12	22	+0.030	+0.088	960	635	240	6,720	4,445	1,680	13
OJUM-03-16	26	+0.030	+0.088	1,440	990	396	10,080	6,943	2,772	19
OJUM-03-20	32	+0.030	+0.091	2,250	1,800	900	15,750	12,600	6,300	38
OJUM-03-25	40	+0.030	+0.091	3,625	2,953	1,523	25,375	20,670	10,658	63
OJUM-03-30	47	+0.040	+0.110	5,100	4,250	2,278	35,700	29,735	15,946	119
OJUM-03-40	62	+0.040	+0.115	8,000	6,810	3,800	56,000	47,660	26,600	250
OJUM-03-50	75	+0.050	+0.150	12,500	10,750	6,125	87,500	75,265	42,875	431

Can be combined with:



Available with drylin® liners (optional: J200/A180):

drylin® R pillow blocks

Closed, anodised aluminium housing, short design



Order key

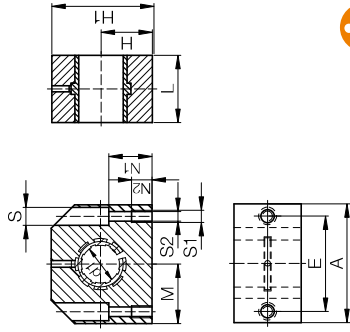

Type	Size
Closed	Inner Ø d1
Liner	
Metric	
Compact	

R J U M -05-10



⁷⁸⁾ According to igus® testing method ▶ Page 1146

⁸¹⁾ Ø < 10mm use press-fitted sleeve bearings

⁸²⁾ Design tips ▶ Page 1078

Please note: Installation instructions ▶ Page 1079

Dimensions [mm]

d1	H	H1	A	M	E	S	S1	S2	N1	N2	L	Part No.	
+0,01 -0,014	8	14	27	32	16,0	23	6,0	M4	3,4	13	9	24	RJUM-05-08 ⁸¹⁾
	10	16	33	40	20,0	29	8,0	M5	4,3	16	11	26	RJUM-05-10
	12	17	33	40	20,0	29	8,0	M5	4,3	16	11	28	RJUM-05-12
	16	19	38	45	22,5	34	8,0	M5	4,3	18	11	30	RJUM-05-16
	20	23	45	53	26,5	40	9,5	M6	5,3	22	13	30	RJUM-05-20
	25	27	54	62	31,0	48	11,0	M8	6,6	26	18	40	RJUM-05-25
	30	30	60	67	33,5	53	11,0	M8	6,6	29	18	50	RJUM-05-30
	40	39	76	87	43,5	69	15,0	M10	8,4	38	22	60	RJUM-05-40
	50	47	92	103	51,5	82	18,0	M12	10,5	46	26	70	RJUM-05-50

Technical data

Part No.	d1 tolerance ⁸¹⁾		Fmax. dynamic ⁸²⁾		Fmax. static ⁸²⁾		Weight
	[mm]	[N]	p = 5MPa	p = 35MPa	[N]	[g]	
RJUM-05-08 ⁸¹⁾	+0,032 +0,070	960	6,720	6,720	46	46	
RJUM-05-10	+0,030 +0,068	650	4,550	4,550	71	71	
RJUM-05-12	+0,030 +0,068	840	5,880	5,880	78	78	
RJUM-05-16	+0,030 +0,068	1,200	8,400	8,400	106	106	
RJUM-05-20	+0,030 +0,091	1,500	10,500	10,500	132	132	
RJUM-05-25	+0,030 +0,091	2,500	17,500	17,500	253	253	
RJUM-05-30	+0,040 +0,110	3,750	26,250	26,250	374	374	
RJUM-05-40	+0,040 +0,115	6,000	42,000	42,000	713	713	
RJUM-05-50	+0,050 +0,150	8,750	61,250	61,250	1,168	1,168	

Available with drylin® liners (optional: J200/A180):



drylin® R pillow blocks

Adjustable anodised aluminium housing, short design



Order key

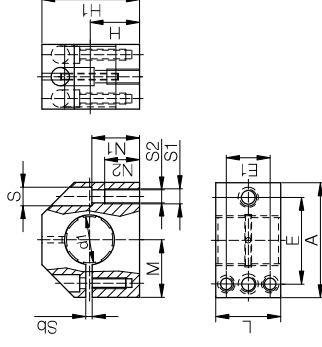

Type	Size
Closed	Inner Ø d1
Liner	
Metric	
Adjustable	
Compact	

R J U M E -05-12



⁷⁸⁾ According to igus® testing method ▶ Page 1146

⁸²⁾ Design tips ▶ Page 1078

Please note: Installation instructions ▶ Page 1079

Dimensions [mm]

d1	H	H1	A	M	E	E1	S	S1	S2	Sb	N1	N2	L	Part No.	
+0,01 -0,014	12	17	33	40	20,0	29	18,0	8,0	4,3	M5	2	16	11	28	RJUME-05-12
	16	19	38	45	22,5	34	19,0	8,0	4,3	M5	2	18	11	30	RJUME-05-16
	20	23	45	53	26,5	40	20,0	9,5	5,3	M6	2	22	13	30	RJUME-05-20
	25	27	54	62	31,0	48	25,5	11,0	6,6	M8	2	26	18	40	RJUME-05-25
	30	30	60	67	33,5	53	30,5	11,0	6,6	M8	2	29	18	50	RJUME-05-30
	40	39	76	87	43,5	69	36,0	15,0	8,4	M10	2	38	22	60	RJUME-05-40
	50	47	92	103	51,5	82	44,0	18,0	10,5	M12	2	46	26	70	RJUME-05-50

Technical data

Part No.	d1 tolerance ⁸¹⁾		Fmax. dynamic ⁸²⁾		Fmax. static ⁸²⁾		Weight
	[mm]	[N]	p = 5MPa	p = 35MPa	[N]	[g]	
RJUME-05-12	Adjustable	840	5,880	5,880	78	78	
RJUME-05-16	Adjustable	1,200	8,400	8,400	106	106	
RJUME-05-20	Adjustable	1,500	10,500	10,500	132	132	
RJUME-05-25	Adjustable	2,500	17,500	17,500	253	253	
RJUME-05-30	Adjustable	3,750	26,250	26,250	374	374	
RJUME-05-40	Adjustable	6,000	42,000	42,000	713	713	
RJUME-05-50	Adjustable	8,750	61,250	61,250	1,168	1,168	

Available with drylin® liners (optional: J200/A180):



drylin® R pillow blocks | Product range

Split anodised aluminium housing, screwed, short design



Order key

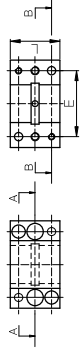

Sectional view A

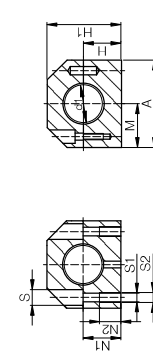

Sectional view B



Type

T J U M-05-16



Size

Inner Ø d1



Open

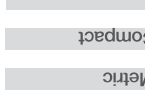

Liner

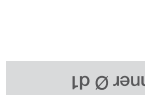

Metric



Compact



Inner Ø d1

- Replacement of the liner without removing the shaft



⁷⁸⁾ According to igus® testing method ▶ Page 1146

⁸²⁾ Design tips ▶ Page 1078

Please note: Installation instructions ▶ Page 1079

Dimensions [mm]

d1	H	H1	A	M	E	S	S1	S2	N1	N2	L	Part No.
	±0,02				±0,15							
16	19	38	45	22,5	34	8,0	M5	4,3	18	11	30	TJUM-05-16
20	23	45	53	26,5	40	9,5	M6	5,3	22	13	30	TJUM-05-20
25	27	54	62	31,0	48	11,0	M8	6,6	26	18	40	TJUM-05-25
30	30	60	67	33,5	53	11,0	M8	6,6	29	18	50	TJUM-05-30
40	39	76	87	43,5	69	15,0	M10	8,4	38	22	60	TJUM-05-40

Technical data

Part No.	d1 tolerance ⁷⁸⁾		Fmax. dynamic ⁸²⁾		Fmax. static ⁸²⁾		Weight
	[mm]	[N]	p = 5MPa	p = 35MPa	[N]	[g]	
TJUM-05-16	+0,030 +0,120	1,200	8,400	8,400	10,500	105	
TJUM-05-20	+0,030 +0,120	1,500	10,500	10,500	17,500	137	
TJUM-05-25	+0,030 +0,120	2,500	17,500	17,500	26,250	253	
TJUM-05-30	+0,040 +0,135	3,750	26,250	26,250	42,000	377	
TJUM-05-40	+0,040 +0,135	6,000	42,000	42,000	720	720	

Available with drylin® liners (optional: J200/A180):



drylin® R pillow blocks | Product range

Closed, anodised aluminium housing, tandem design



Order key

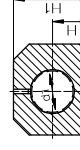

Sectional view A

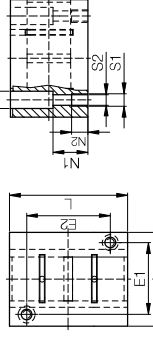

Sectional view B



Type

R J U M T-05-12



Size

Inner Ø d1



Closed

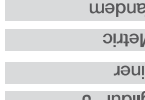

Liner



Metric



Tandem



Compact

Inner Ø d1

- Tandem design



⁷⁸⁾ According to igus® testing method ▶ Page 1146

⁸²⁾ Design tips ▶ Page 1078

Please note: Installation instructions ▶ Page 1079

Dimensions [mm]

d1	H	H1	A	M	E1	E2	S	S1	S2	N1	N2	L	Part No.
	+0,01				±0,15	±0,15							
	-0,014												
12	17	33	40	20	29	35	8,0	M5	4,3	16,0	11	60	RJUMT-05-12
16	19	38	45	22,5	34	40	8,0	M5	4,3	18,0	11	65	RJUMT-05-16
20	23	45	53	26,5	40	45	9,5	M6	5,3	22,0	13	65	RJUMT-05-20
25	27	54	62	31	48	55	11,0	M8	6,6	26,0	18	85	RJUMT-05-25
30	30	60	67	33,5	53	70	11,0	M8	6,6	29,0	18	105	RJUMT-05-30
40	39	76	87	43,5	69	85	15,0	M10	8,4	38,0	22	125	RJUMT-05-40
50	47	92	103	51,5	82	100	18,0	M12	10,5	46,0	26	145	RJUMT-05-50

Technical data

Part No.	d1 tolerance ⁷⁸⁾		Fmax. dynamic ⁸²⁾		Fmax. static ⁸²⁾		Weight
	[mm]	[N]	p = 5MPa	p = 35MPa	[N]	[g]	
RJUMT-05-12	+0,030 +0,088	840	5,880	5,880	8,400	170	
RJUMT-05-16	+0,030 +0,088	1,200	8,400	8,400	10,500	250	
RJUMT-05-20	+0,030 +0,091	1,500	10,500	10,500	17,500	300	
RJUMT-05-25	+0,030 +0,091	2,500	17,500	17,500	26,250	550	
RJUMT-05-30	+0,040 +0,110	3,750	26,250	26,250	42,000	750	
RJUMT-05-40	+0,040 +0,115	6,000	42,000	42,000	72,000	1,500	
RJUMT-05-50	+0,050 +0,150	8,750	61,250	61,250	105,000	2,400	

Available with drylin® liners (optional: J200/A180):



drylin® R pillow blocks | Product range

Closed, anodised aluminium housing, long design



Order key

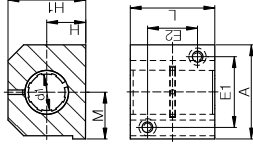

R J U M-06-12

Type Closed
Liner iglidur® J
Metric
Long design
Size Inner Ø d1



78) According to igus® testing method ▶ Page 1146

82) Design tips ▶ Page 1078

Please note: Installation instructions ▶ Page 1079

Dimensions [mm]

d1	H	H1	A	M	E1	E2	S	S1	S2	N1	N2	L	Part No.
+0,01; -0,014													
12	18	35	43	21,5	32	23	8,0	M5	4,3	16,5	11	39	RJUM-06-12
16	22	42	53	26,5	40	26	10,0	M6	5,3	21,0	13	43	RJUM-06-16
20	25	50	60	30,0	45	32	11,0	M8	6,6	24,0	18	54	RJUM-06-20
25	30	60	78	39,0	60	40	15,0	M10	8,4	29,0	22	67	RJUM-06-25
30	35	70	87	43,5	68	45	15,0	M10	8,4	34,0	22	79	RJUM-06-30
40	45	90	108	54,0	86	58	18,0	M12	10,5	44,0	26	91	RJUM-06-40
50	50	105	132	66,0	108	50	20,0	M16	13,5	49,0	34	113	RJUM-06-50

Technical data

Part No.	d1 tolerance ⁷⁸⁾		Fmax. dynamic ⁸²⁾		Fmax. static ⁸²⁾		Weight
	[mm]	[N]	[N]	[N]	[N]	[g]	
RJUM-06-12	+0,030	+0,088	960	6,720	6,720	121	
RJUM-06-16	+0,030	+0,088	1,440	10,080	10,080	211	
RJUM-06-20	+0,030	+0,091	2,250	15,750	15,750	323	
RJUM-06-25	+0,030	+0,091	3,625	25,375	25,375	651	
RJUM-06-30	+0,040	+0,110	5,100	35,700	35,700	1,050	
RJUM-06-40	+0,040	+0,115	8,000	56,000	56,000	1,820	
RJUM-06-50	+0,050	+0,150	12,500	87,500	87,500	3,250	

Available with drylin® liners (optional: J200/A180):



J

E7

X

1122 Online tools and more information ▶ www.igus-asean.com/drylinR

drylin® R pillow blocks | Product range

Closed, anodised aluminium housing, long design with manual clamp



Order key

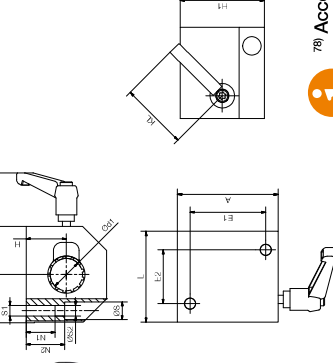

R J U M-06-12 - HK

Type Closed
Liner iglidur® J
Metric
Long design
Size Inner Ø d1
Options Manual clamp



78) According to igus® testing method ▶ Page 1146

82) Design tips ▶ Page 1078

Please note: Installation instructions ▶ Page 1079

Dimensions [mm]

d1	H	H1	A	M	E1	E2	S	S1	S2	N1	N2	L	KL	KB	Part No.	
+0,01; -0,014																
±0,02 ±0,15 ±0,15																
-1																
12	18	35	43	21,5	32	23	8	M5	4,3	16,5	11	10,2	39	40	33	RJUM-06-12-HK
16	22	42	53	26,5	40	26	10	M6	5,3	21	13	11,6	43	40	33	RJUM-06-16-HK
20	25	50	60	30	45	32	11	M8	6,6	24	18	12	54	40	33	RJUM-06-20-HK
25	30	60	78	39	60	40	15	M10	8,4	29	22	14,5	67	65	46	RJUM-06-25-HK
30	35	70	87	43,5	68	45	15	M10	8,4	34	22	16,6	79	65	46	RJUM-06-30-HK
40	45	90	108	54	86	58	18	M12	10,5	44	26	21	91	65	46	RJUM-06-40-HK
50	50	105	132	66	108	50	20	M16	13,5	49	34	25,5	113	65	46	RJUM-06-50-HK

Technical data

Part No.	d1 tolerance ⁷⁸⁾		Fmax. dynamic ⁸²⁾		Fmax. static ⁸²⁾		Clamp force	Weight
	[mm]	[N]	[N]	[N]	[N]	[g]		
RJUM-06-12-HK	+0,030	+0,088	960	6,720	6,720	400	0,098	
RJUM-06-16-HK	+0,030	+0,088	1,440	10,080	10,080	400	0,164	
RJUM-06-20-HK	+0,030	+0,091	2,250	15,750	15,750	400	0,275	
RJUM-06-25-HK	+0,030	+0,091	3,625	25,375	25,375	1,000	0,544	
RJUM-06-30-HK	+0,040	+0,110	5,100	35,700	35,700	1,000	0,832	
RJUM-06-40-HK	+0,040	+0,115	8,000	56,000	56,000	1,000	1,513	
RJUM-06-50-HK	+0,050	+0,150	12,500	87,500	87,500	1,000	2,568	

Available with drylin® liners (optional: J200/A180):



J

E7

X

3D CAD files, prices and delivery time online ▶ www.igus-asean.com/drylinR 1123

drylin® R pillow blocks

Closed, anodised aluminium, floating pillow blocks



Order key

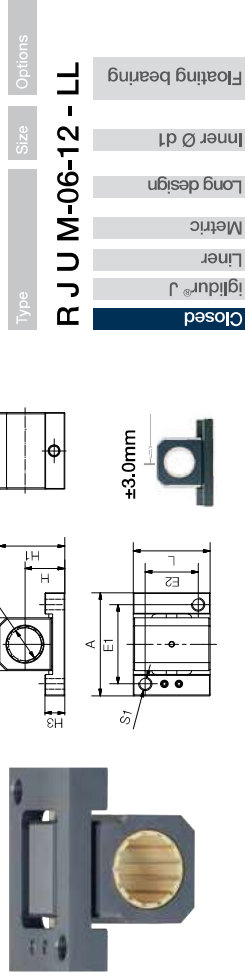

- Compensation of parallelism errors up to 6mm
- Quick assembly even on raw profiles



⁷⁸⁾ According to igus® testing method ▶ Page 1146
⁸²⁾ Design tips ▶ Page 1078
 Please note: Installation instructions ▶ Page 1079
 Floating bearing ▶ Page 1078

Dimensions [mm]

d1	H	H1	A	E1	E2	S1	L	A1	H3	Part No.
	±0,01			±0,15	±0,15					
12	18	28	43	32	23	M5	32	20	11	RJUM-06-12 LL
16	22	35	53	40	26	M6	36	26	11	RJUM-06-16 LL
20	25	41	60	45	32	M8	45	32	12,5	RJUM-06-20 LL
25	30	50	78	60	40	M10	58	40	15	RJUM-06-25 LL
30	35	59	87	68	45	M10	68	48	15	RJUM-06-30 LL
40	45	76	108	86	58	M12	80	62	20	RJUM-06-40 LL
50	50	89	132	108	50	M16	100	78	24	RJUM-06-50 LL

Technical data

Part No.	d1 tolerance ⁷⁸⁾		Fmax. static or dynamic ⁸²⁾ [N]	Weight [g]
	[mm]	[mm]		
RJUM-06-12 LL	+0,030	+0,088	560	50
RJUM-06-16 LL	+0,030	+0,088	920	80
RJUM-06-20 LL	+0,030	+0,091	2,100	130
RJUM-06-25 LL	+0,030	+0,091	3,550	280
RJUM-06-30 LL	+0,040	+0,110	5,300	430
RJUM-06-40 LL	+0,040	+0,115	8,000	850
RJUM-06-50 LL	+0,050	+0,150	12,500	1,550

Available with drylin® liners (optional: J200/A180):

1124 Online tools and more information ▶ www.igus-asean.com/drylinR

drylin® R pillow blocks

Open, anodised aluminium, floating pillow blocks



Order key

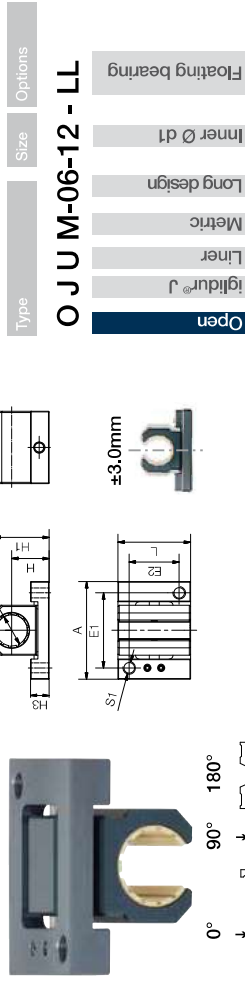

- Compensation of parallelism errors up to 6mm



⁷⁸⁾ According to igus® testing method ▶ Page 1146
⁸²⁾ Design tips ▶ Page 1078
 Please note: Installation instructions ▶ Page 1079
 Floating bearing ▶ Page 1078

Dimensions [mm]

d1	H	H1	A	E1	E2	S1	L	A1	H3	W	α	Part No.
	±0,01			±0,15	±0,15					-1	[°]	
12	18	24,5	43	32	23	M5	32	20	11	10,2	90	OJUM-06-12 LL
16	22	30,5	53	40	26	M6	36	26	11	11,6	90	OJUM-06-16 LL
20	25	37,0	60	45	32	M8	45	32	12,5	12,0	60	OJUM-06-20 LL
25	30	44,0	78	60	40	M10	58	40	15	14,5	60	OJUM-06-25 LL
30	35	52,5	87	68	45	M10	68	48	15	16,8	60	OJUM-06-30 LL
40	45	69,0	108	86	58	M12	80	62	20	21,0	60	OJUM-06-40 LL
50	50	80,0	132	108	50	M16	100	78	24	25,5	60	OJUM-06-50 LL

Technical data

Part No.	d1 tolerance ⁷⁸⁾		Fmax. static or dynamic ⁸²⁾ [N]	Fmax. static ⁸²⁾ with load at 180° [N]	Weight [g]
	[mm]	[mm]			
OJUM-06-12 LL	+0,030	+0,088	560	240	40
OJUM-06-16 LL	+0,030	+0,088	920	400	70
OJUM-06-20 LL	+0,030	+0,091	2,100	900	115
OJUM-06-25 LL	+0,030	+0,091	3,550	1,520	240
OJUM-06-30 LL	+0,040	+0,110	5,100	2,280	370
OJUM-06-40 LL	+0,040	+0,115	8,000	3,800	750
OJUM-06-50 LL	+0,050	+0,150	12,500	6,100	1,400

Available with drylin® liners (optional: J200/A180):

1124 Online tools and more information ▶ www.igus-asean.com/drylinR

drylin® R pillow blocks | Product range

Open, anodised aluminium housing, long design



Order key

Type: Open

Size: Inner Ø d1

Options: Metric, Liner, iglidur® J, Long design

O J U M-06-12

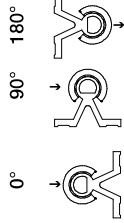
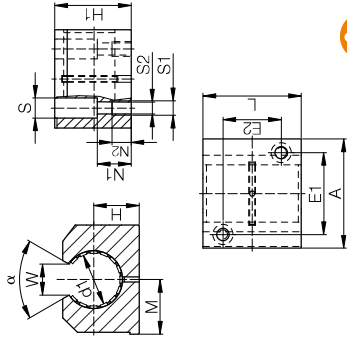

⁷⁸⁾ According to igus® testing method ▶ Page 1146
⁸²⁾ Design tips ▶ Page 1078

Please note: Installation instructions ▶ Page 1079

Dimensions [mm]

d1	H	H1	A	M	E1	E2	S	S1	S2	N1	N2	W	α	L	Part No.
													-1		
					±0.02	±0.15	±0.15								
12	18	28	43	21.5	32	23	8.0	M5	4.3	16.5	11	10.2	78	39	OJUM-06-12
16	22	35	53	26.5	40	26	10.0	M6	5.3	21.0	13	11.6	78	43	OJUM-06-16
20	25	42	60	30.0	45	32	11.0	M8	6.6	24.0	18	12.0	60	54	OJUM-06-20
25	30	51	78	39.0	60	40	15.0	M10	8.4	29.0	22	14.5	60	67	OJUM-06-25
30	35	60	87	43.5	68	45	15.0	M10	8.4	34.0	22	16.6	57	79	OJUM-06-30
40	45	77	108	54.0	86	58	18.0	M12	10.5	44.0	26	21.0	56	91	OJUM-06-40
50	50	88	132	66.0	108	50	20.0	M16	13.5	49.0	34	25.5	54	113	OJUM-06-50

Technical data

Part No.	d1 tolerance ⁷⁸⁾	Fmax. dynamic ⁸²⁾ p = 5MPa			Fmax. static ⁸²⁾ p = 35MPa			Weight [g]
		0°	90°	180°	0°	90°	180°	
OJUM-06-12	+0,030 +0,088	960	635	240	6,720	4,445	1,680	95
OJUM-06-16	+0,030 +0,088	1440	990	396	10,080	6,943	2,772	158
OJUM-06-20	+0,030 +0,091	2250	1,800	900	15,750	12,600	6,300	266
OJUM-06-25	+0,030 +0,091	3625	2,953	1,523	25,375	20,670	10,658	530
OJUM-06-30	+0,040 +0,110	5100	4,250	2,278	35,700	29,795	15,946	818
OJUM-06-40	+0,040 +0,115	8000	6,810	3,800	56,000	47,660	26,600	1,485
OJUM-06-50	+0,050 +0,150	12,500	10,750	6,125	87,500	75,265	42,875	2,750

Available with drylin® liners (optional: J200/A180):

1126 Online tools and more information ▶ www.igus-asean.com/drylinR

drylin® R pillow blocks | Product range

Open, anodised aluminium housing, long design with manual clamp



Order key

Type: Open

Size: Inner Ø d1

Options: Metric, Liner, iglidur® J, Long design, Manual clamp

O J U M-06-12 - HK

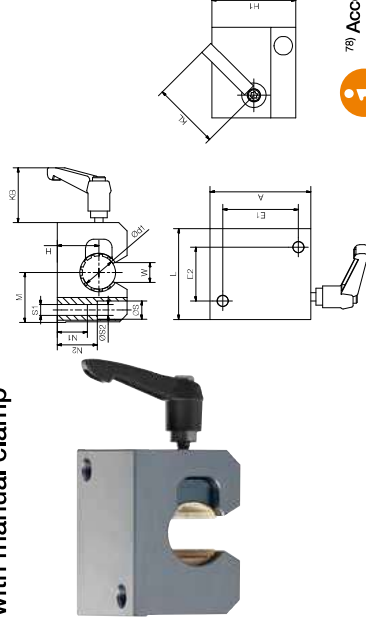

⁷⁸⁾ According to igus® testing method ▶ Page 1146
⁸²⁾ Design tips ▶ Page 1078

Please note: Installation instructions ▶ Page 1079

Dimensions [mm]

d1	H	H1	A	M	E1	E2	S	S1	S2	N1	N2	W	L	KL	KB	Part No.
					±0.02	±0.15	±0.15									
12	18	28	43	21.5	32	23	8	M5	4.3	16.5	11	10.2	39	40	33	OJUM-06-12-HK
16	22	35	53	26.5	40	26	10	M6	5.3	21	13	11.6	43	40	33	OJUM-06-16-HK
20	25	42	60	30.0	45	32	11	M8	6.6	24	18	12.0	54	40	33	OJUM-06-20-HK
25	30	51	78	39.0	60	40	15	M10	8.4	29	22	14.5	67	65	46	OJUM-06-25-HK
30	35	60	87	43.5	68	45	15	M10	8.4	34	22	16.6	79	65	46	OJUM-06-30-HK
40	45	77	108	54.0	86	58	18	M12	10.5	44	26	21.0	91	65	46	OJUM-06-40-HK
50	50	88	132	66.0	108	50	20	M16	13.5	49	34	25.5	113	65	46	OJUM-06-50-HK

Technical data

Part No.	d1 tolerance ⁷⁸⁾	Fmax. dynamic ⁸²⁾ p = 5MPa			Fmax. static ⁸²⁾ p = 35MPa			Clamp force Weight axial [N] [g]
		0°	90°	180°	0°	90°	180°	
OJUM-06-12-HK	+0,030 +0,088	960	635	240	6,720	4,445	1,680	400 0,098
OJUM-06-16-HK	+0,030 +0,088	1440	990	396	10,080	6,943	2,772	400 0,164
OJUM-06-20-HK	+0,030 +0,091	2250	1800	900	15,750	12,600	6,300	400 0,275
OJUM-06-25-HK	+0,030 +0,091	3625	2953	1523	25,375	20,670	10,658	1,000 0,544
OJUM-06-30-HK	+0,040 +0,110	5100	4250	2278	35,700	29,795	15,946	1,000 0,832
OJUM-06-40-HK	+0,040 +0,115	8000	6810	3800	56,000	47,660	26,600	1,000 1,513
OJUM-06-50-HK	+0,050 +0,150	12,500	10,750	6,125	87,500	75,265	42,875	1,000 2,568

Available with drylin® liners (optional: J200/A180):

3D CAD files, prices and delivery time online ▶ www.igus-asean.com/drylinR 1127

drylin® R pillow blocks | Product range

Open, anodised aluminium housing, long design, adjustable

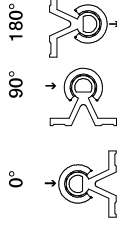
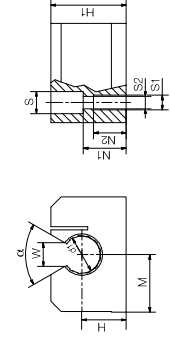

- With two set screws (DIN 913), clearance adjustment possible



⁷⁸⁾ According to igus® testing method ▶ Page 1146
⁸²⁾ Design tips ▶ Page 1078
Please note: Installation instructions ▶ Page 1079



Order key

Type	Size
Open	Long design
igidur® J	Adjustable
Liner	Metric
O J U M E-06-12	Inner Ø d1

Dimensions [mm]

d1	H	H1	A	M	E1	E2	S	S1	S2	S3	N1	N2	W	α	L	Part No.
					±0.02	±0.15							-1			
12	18	28	43	21.5	32	23	8.0	M5	4.3	M4	16.5	11	10.2	78	39	OJUME-06-12
16	22	35	53	26.5	40	26	10.0	M6	5.3	M4	21.0	13	11.6	78	43	OJUME-06-16
20	25	42	60	30.0	45	32	11.0	M8	6.6	M5	24.0	18	12.0	60	54	OJUME-06-20
25	30	51	78	39.0	60	40	15.0	M10	8.4	M6	29.0	22	14.5	60	67	OJUME-06-25
30	35	60	87	43.5	68	45	15.0	M10	8.4	M6	34.0	22	16.6	57	79	OJUME-06-30
40	45	77	108	54.0	86	58	18.0	M12	10.5	M8	44.0	26	21.0	56	91	OJUME-06-40
50	50	88	132	66.0	108	50	20.0	M16	13.5	M8	49.0	34	25.5	54	113	OJUME-06-50

Technical data

Part No.	d1 tolerance ⁷⁸⁾	Fmax. dynamic ⁸²⁾			Fmax. static ⁸²⁾			Weight [g]
		p = 5MPa						
		0°	90°	180°	0°	90°	180°	
OJUME-06-12	Adjustable	960	635	240	6,720	4,445	1,680	100
OJUME-06-16	Adjustable	1,440	990	396	10,080	6,943	2,772	160
OJUME-06-20	Adjustable	2,250	1,800	900	15,750	12,600	6,300	270
OJUME-06-25	Adjustable	3,625	2,953	1,523	25,375	20,670	10,658	530
OJUME-06-30	Adjustable	5,100	4,250	2,278	35,700	29,735	15,946	820
OJUME-06-40	Adjustable	8,000	6,810	3,800	56,000	47,660	26,600	1,490
OJUME-06-50	Adjustable	12,500	10,750	6,125	87,500	75,265	42,875	2,750

Available with drylin® liners (optional: J200/A180):

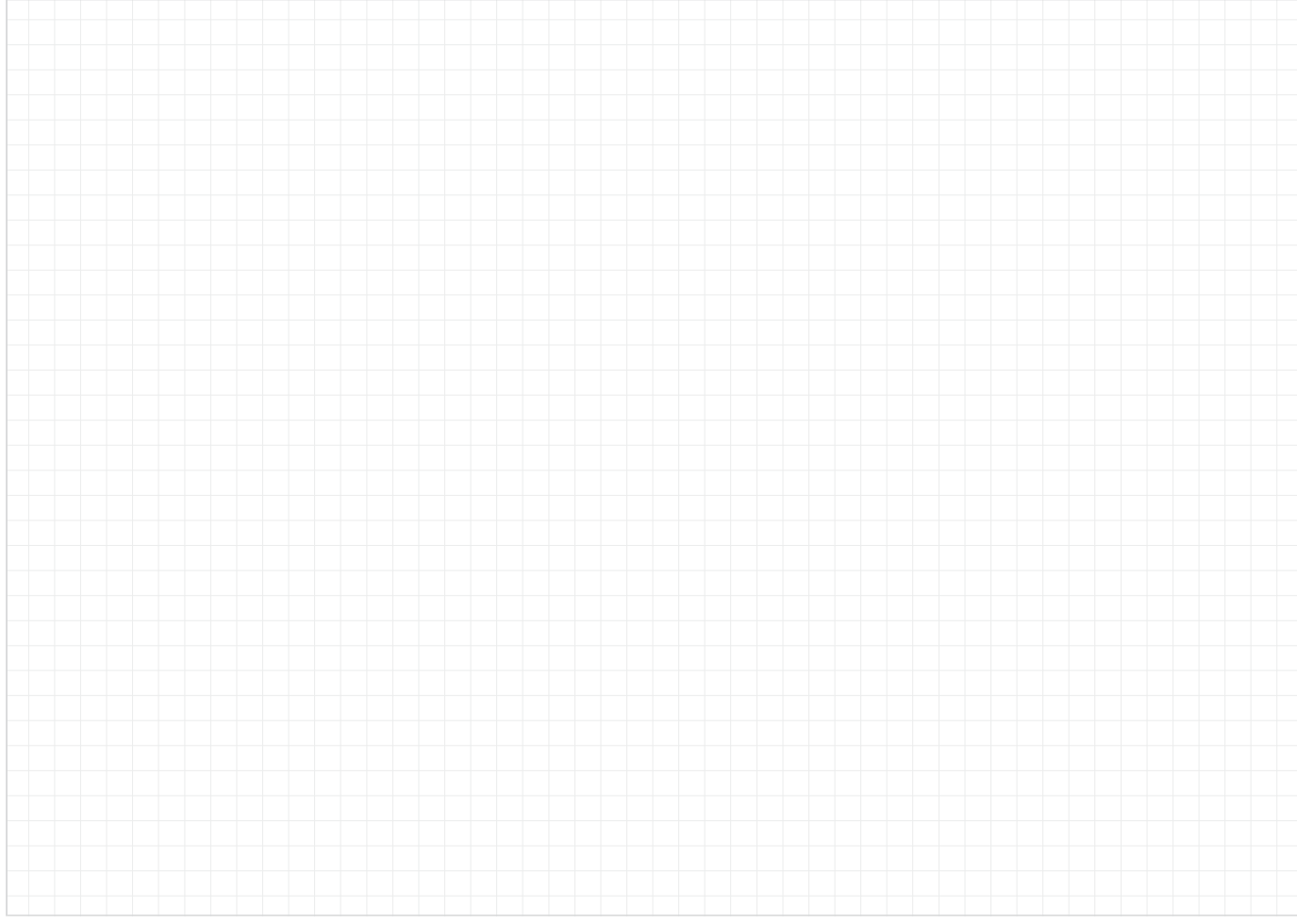

drylin® R flanged linear plain bearings | Product range

Closed, anodised aluminium adapter, round flange

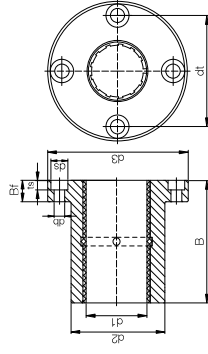

⁷⁸⁾ According to igus® testing method ▶ Page 1146

⁸²⁾ Design tips ▶ Page 1078

Please note: Installation instructions ▶ Page 1079

Dimensions [mm]

d1	d2 h7	d3	dt	B	Bf	ts	db	ds	Part No.
8.0	16	32	24	25	8	3.1	3.5	6.0	FJZM-01-08
10.0	19	39	29	29	9	4.1	4.5	7.5	FJUM-01-10
10.4	19	39	29	29	9	4.1	4.5	7.5	FJUM-01-10-LL
12.0	22	42	32	32	9	4.1	4.5	7.5	FJUM-01-12
12.4	22	42	32	32	9	4.1	4.5	7.5	FJUM-01-12-LL
16.0	26	46	36	36	9	4.1	4.5	7.5	FJUM-01-16
16.4	26	46	36	36	9	4.1	4.5	7.5	FJUM-01-16-LL
20.0	32	54	43	45	11	5.1	5.5	9.0	FJUM-01-20
20.5	32	54	43	45	11	5.1	5.5	9.0	FJUM-01-20-LL
25.0	40	62	51	58	11	5.1	5.5	9.0	FJUM-01-25
25.5	40	62	51	58	11	5.1	5.5	9.0	FJUM-01-25-LL
30.0	47	76	62	68	14	6.1	6.6	11.0	FJUM-01-30
30.6	47	76	62	68	14	6.1	6.6	11.0	FJUM-01-30-LL
40.0	62	98	80	80	18	8.1	9.0	14.0	FJUM-01-40
50.0	75	112	94	100	18	8.1	9.0	14.0	FJUM-01-50

Available with drylin® liners (optional: J200/A180):



drylin® R flanged linear plain bearings | Product range



Order key

Type	Size
With flange	
iglidur® J	
Liner	
Metric	
Round design	Inner Ø d1

F J U M-01-10-LL

Option:
LL: Floating bearing

Technical data

Part No.	d1 tolerance ⁷⁸⁾ [mm]	Fmax. dynamic ⁸²⁾ p = 5MPa		Fmax. static ⁸²⁾ p = 35MPa		Weight
		[N]	[g]	[N]	[g]	
FJZM-01-08	+0.032 +0.070	960	20	6,720	20	
FJUM-01-10	+0.030 +0.088	725	32	5,075	32	
FJUM-01-10-LL	+0.030 +0.088	725	32	5,075	32	
FJUM-01-12	+0.030 +0.088	960	42	6,720	42	
FJUM-01-12-LL	+0.030 +0.088	960	42	6,720	42	
FJUM-01-16	+0.030 +0.088	1,440	51	10,080	51	
FJUM-01-16-LL	+0.030 +0.088	1,440	51	10,080	51	
FJUM-01-20	+0.030 +0.091	2,250	88	15,750	88	
FJUM-01-20-LL	+0.030 +0.091	2,250	88	15,750	88	
FJUM-01-25	+0.030 +0.091	3,625	152	25,375	152	
FJUM-01-25-LL	+0.030 +0.091	3,625	152	25,375	152	
FJUM-01-30	+0.040 +0.110	5,100	266	35,700	266	
FJUM-01-30-LL	+0.040 +0.110	5,100	266	35,700	266	
FJUM-01-40	+0.040 +0.115	8,000	552	56,000	552	
FJUM-01-50	+0.050 +0.150	12,500	853	87,500	853	

drylin® R flanged linear plain bearings | Product range

Closed, anodised aluminium adapter, square flange

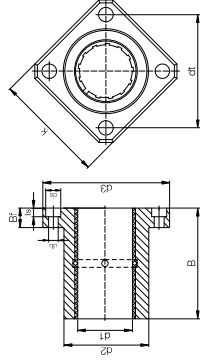

⁷⁸⁾ According to igus® testing method ▶ Page 1146

⁸²⁾ Design tips ▶ Page 1078

Please note: Installation instructions ▶ Page 1079

Dimensions [mm]

d1	d2	d3	dt	k	B	Bf	ts	db	ds	Part No.
±0.01	h7		±0.15	±0.15						
8.0	16	32	24	25	25	8	3.1	3.5	6.0	FJZM-02-08 ⁸²⁾
10.0	19	39	29	30	29	9	4.1	4.5	7.5	FJUM-02-10
10.4	19	39	29	30	29	9	4.1	4.5	7.5	FJUM-02-10-LL
12.0	22	42	32	32	32	9	4.1	4.5	7.5	FJUM-02-12
12.4	22	42	32	32	32	9	4.1	4.5	7.5	FJUM-02-12-LL
16.0	26	46	36	35	36	9	4.1	4.5	7.5	FJUM-02-16
16.4	26	46	36	35	36	9	4.1	4.5	7.5	FJUM-02-16-LL
20.0	32	54	43	42	45	11	5.1	5.5	9.0	FJUM-02-20
20.5	32	54	43	42	45	11	5.1	5.5	9.0	FJUM-02-20-LL
25.0	40	62	51	50	58	11	5.1	5.5	9.0	FJUM-02-25
25.5	40	62	51	50	58	11	5.1	5.5	9.0	FJUM-02-25-LL
30.0	47	76	62	60	68	14	6.1	6.6	11.0	FJUM-02-30
30.6	47	76	62	60	68	14	6.1	6.6	11.0	FJUM-02-30-LL
40.0	62	98	80	75	80	18	8.1	9.0	14.0	FJUM-02-40
50.0	75	112	94	88	100	18	8.1	9.0	14.0	FJUM-02-50

Available with drylin® liners (optional: J200/A180):



drylin® R flanged linear plain bearings | Product range



Order key

Type	Size
With flange	
igidur® J	
Liner	
Metric	
Square design	Inner Ø d1

F J U M-02-10-LL

Option:
LL: Floating bearing

Technical data

Part No.	d1 tolerance ⁷⁸⁾ [mm]	Fmax. static or dynamic ⁸²⁾ [N]	Fmax. static ⁸²⁾ with load at 180° [N]	Weight [g]
FJZM-02-08 ⁸²⁾	+0.032 +0.070	960	6,720	17
FJUM-02-10	+0.030 +0.088	725	5,075	25
FJUM-02-10-LL	+0.030 +0.088	725	5,075	25
FJUM-02-12	+0.030 +0.088	960	6,720	32
FJUM-02-12-LL	+0.030 +0.088	960	6,720	32
FJUM-02-16	+0.030 +0.088	1,440	10,080	41
FJUM-02-16-LL	+0.030 +0.088	1,440	10,080	41
FJUM-02-20	+0.030 +0.091	2,250	15,750	73
FJUM-02-20-LL	+0.030 +0.091	2,250	15,750	73
FJUM-02-25	+0.030 +0.091	3,625	25,375	135
FJUM-02-25-LL	+0.030 +0.091	3,625	25,375	135
FJUM-02-30	+0.040 +0.110	5,100	35,700	228
FJUM-02-30-LL	+0.040 +0.110	5,100	35,700	228
FJUM-02-40	+0.040 +0.115	8,000	56,000	454
FJUM-02-50	+0.050 +0.150	12,500	87,500	735

Closed, anodised aluminium adapter, round flange, tandem design

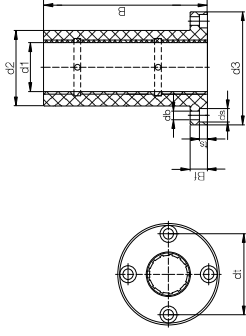

- Equipped with two liners to increase the guide length



⁷⁸⁾ According to igus® testing method ▶ Page 1146
⁸⁹⁾ Fitted with two pieces of JSM-0810-16

Please note: Installation instructions ▶ Page 1079

Dimensions [mm]

d1	d2	d3	dt	B	Bf	ts	db	ds	Part No.
8.0	16	32	24	45	8	3.1	3.5	6.0	FJZMT-01-08 ⁸⁹⁾
10.0	19	39	29	52	9	4.1	4.5	7.5	FJUMT-01-10
10.4	19	39	29	52	9	4.1	4.5	7.5	FJUMT-01-10-LL
12.0	22	42	32	57	9	4.1	4.5	7.5	FJUMT-01-12
12.4	22	42	32	57	9	4.1	4.5	7.5	FJUMT-01-12-LL
16.0	26	46	36	70	9	4.1	4.5	7.5	FJUMT-01-16
16.4	26	46	36	70	9	4.1	4.5	7.5	FJUMT-01-16-LL
20.0	32	54	43	80	11	5.1	5.5	9.0	FJUMT-01-20
20.5	32	54	43	80	11	5.1	5.5	9.0	FJUMT-01-20-LL
25.0	40	62	51	112	11	5.1	5.5	9.0	FJUMT-01-25
25.5	40	62	51	112	11	5.1	5.5	9.0	FJUMT-01-25-LL
30.0	47	76	62	123	14	6.1	6.6	11.0	FJUMT-01-30
30.6	47	76	62	123	14	6.1	6.6	11.0	FJUMT-01-30-LL
40.0	62	98	80	151	18	8.1	9.0	14.0	FJUMT-01-40
50.0	75	112	94	192	18	8.1	9.0	14.0	FJUMT-01-50

Available with drylin® liners (optional: J200/A180):



Order key

Type	Size
With flange	
iglidur® J	
Liner	
Metric	
Tandem	
Round design	
	Inner Ø d1

F J U M T-01-10-LL

Option:
LL: Floating bearing

Technical data

Part No.	Dimension nominal diameter [mm]	d1 tolerance ⁷⁸⁾ [mm]	Guide length [mm]	Projected bearing surface [N]	Weight [g]
FJZMT-01-08 ⁸⁹⁾	8	+0,032 +0,070	45	256	27,13
FJUMT-01-10	10	+0,030 +0,088	52	250	43,75
FJUMT-01-10-LL	10	+0,030 +0,088	52	250	43,75
FJUMT-01-12	12	+0,030 +0,088	57	324	57,00
FJUMT-01-12-LL	12	+0,030 +0,088	57	324	57,00
FJUMT-01-16	16	+0,030 +0,088	70	464	78,28
FJUMT-01-16-LL	16	+0,030 +0,088	70	464	78,28
FJUMT-01-20	20	+0,030 +0,091	80	580	126,42
FJUMT-01-20-LL	20	+0,030 +0,091	80	580	126,42
FJUMT-01-25	25	+0,030 +0,091	112	975	248,85
FJUMT-01-25-LL	25	+0,030 +0,091	112	975	248,85
FJUMT-01-30	30	+0,040 +0,110	123	1,470	388,37
FJUMT-01-30-LL	30	+0,040 +0,110	123	1,470	388,37
FJUMT-01-40	40	+0,040 +0,115	151	2,360	835,00
FJUMT-01-50	50	+0,050 +0,150	192	3,450	1,352,30

drylin® R flanged linear plain bearings | Product range

Closed, anodised aluminium adapter, square flange, tandem design

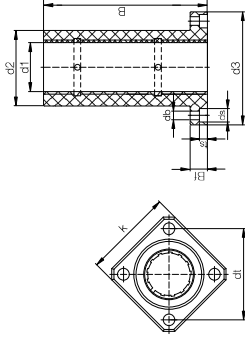

- Equipped with two liners to increase the guide length



⁷⁸⁾ According to igus® testing method ▶ Page 1146

⁸⁹⁾ Fitted with two pieces of JSM-0810-16

Please note: Installation instructions ▶ Page 1079

Dimensions [mm]

d1	d2	d3	dt	dk	B	Bf	ts	db	ds	Part No.
8,0	16	32	24	25	45	8	3,1	3,5	6,0	FJZMT-02-08 ⁸⁹⁾
10,0	19	39	29	30	52	9	4,1	4,5	7,5	FJUMT-02-10
10,4	19	39	29	30	52	9	4,1	4,5	7,5	FJUMT-02-10-LL
12,0	22	42	32	32	57	9	4,1	4,5	7,5	FJUMT-02-12
12,4	22	42	32	32	57	9	4,1	4,5	7,5	FJUMT-02-12-LL
16,0	26	46	36	35	70	9	4,1	4,5	7,5	FJUMT-02-16
16,4	26	46	36	35	70	9	4,1	4,5	7,5	FJUMT-02-16-LL
20,0	32	54	43	42	80	11	5,1	5,5	9,0	FJUMT-02-20
20,5	32	54	43	42	80	11	5,1	5,5	9,0	FJUMT-02-20-LL
25,0	40	62	51	50	112	11	5,1	5,5	9,0	FJUMT-02-25
25,5	40	62	51	50	112	11	5,1	5,5	9,0	FJUMT-02-25-LL
30,0	47	76	62	60	123	14	6,1	6,6	11,0	FJUMT-02-30
30,6	47	76	62	60	123	14	6,1	6,6	11,0	FJUMT-02-30-LL
40,0	62	98	80	75	151	18	8,1	9,0	14,0	FJUMT-02-40
50,0	75	112	94	88	192	18	8,1	9,0	14,0	FJUMT-02-50

Available with drylin® liners (optional: J200/A180):



drylin® R flanged linear plain bearings | Product range



Order key

Type	Size
With flange	F J U M T-02-10-LL
iglidur® J	
Liner	
Metric	
Tandem	
Square design	
Inner Ø d1	

Option:

LL: Floating bearing

Technical data

Part No.	Dimension nominal diameter [mm]	d1 tolerance ⁷⁸⁾ [mm]	Guide length [mm]	Projected bearing surface [N]	Weight [g]
FJZMT-02-08 ⁸⁹⁾	8	+0,032 +0,070	45	256	23,00
FJUMT-02-10	10	+0,030 +0,088	52	250	36,58
FJUMT-02-10-LL	10	+0,030 +0,088	52	250	36,58
FJUMT-02-12	12	+0,030 +0,088	57	324	48,19
FJUMT-02-12-LL	12	+0,030 +0,088	57	324	48,19
FJUMT-02-16	16	+0,030 +0,088	70	464	67,79
FJUMT-02-16-LL	16	+0,030 +0,088	70	464	67,79
FJUMT-02-20	20	+0,030 +0,091	80	580	110,06
FJUMT-02-20-LL	20	+0,030 +0,091	80	580	110,06
FJUMT-02-25	25	+0,030 +0,091	112	975	230,06
FJUMT-02-25-LL	25	+0,030 +0,091	112	975	230,06
FJUMT-02-30	30	+0,040 +0,110	123	1,470	350,74
FJUMT-02-30-LL	30	+0,040 +0,110	123	1,470	350,74
FJUMT-02-40	40	+0,040 +0,115	151	2,360	739,30
FJUMT-02-50	50	+0,050 +0,150	192	3,450	1,249,30

drylin® R quad blocks | Product range
Closed design

Order key



Type	Option	Size
Quad block with RUM bearings	Aluminium housing	Inner Ø d1
	Standard with RJUM-01	

- Housing: Aluminium, equipped with four drylin® R linear plain bearings

Options:
01: Standard with RJUM-01
03: with RJUM-03
04: with RJUM-01

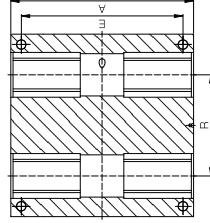
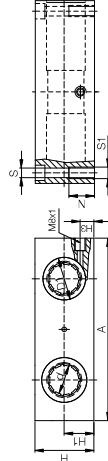

Please note:
Installation instructions
▶ Page 1079

Dimensions [mm]

d	D1	A	H	H1	H3	R	N	E	S	S1	Part No. Standard with	Self-aligning with	Solid plastic bearings with
8	16	65	23	11,5	8	32	11	55	4,3	M5	RQA-01-08	RJUM-01	RQA-04-08
10	19	70	25	12,5	10	34	13	60	4,3	M5	RQA-01-10	RJUM-03	RQA-04-10
12	22	85	32	16	13	42	13	73	5,3	M6	RQA-01-12	RJUM-03	RQA-04-12
16	26	100	36	18	15	54	13	88	5,3	M6	RQA-01-16	RJUM-03	RQA-04-16
20	32	130	46	23	19	72	18	115	6,6	M8	RQA-01-20	RJUM-03	RQA-04-20
25	40	160	56	28	24	88	22	140	8,4	M10	RQA-01-25	RJUM-03	RQA-04-25
30	47	180	64	32	27	96	26	158	10,5	M12	RQA-01-30	RJUM-03	RQA-04-30
40	62	230	80	40	35	122	34	202	13,5	M16	RQA-01-40	RJUM-03	RQA-04-40

Are equipped with:



Available with drylin® liners (optional: J200/A180):

drylin® R quad blocks | Product range
Open design

Order key



Type	Option	Size
Quad block with OJUM bearings	Aluminium housing	Inner Ø d1
	Standard with OJUM-01	

- Housing: Aluminium, equipped with four drylin® R linear plain bearings

Options:
01: Standard with OJUM-01
03: with OJUM-03

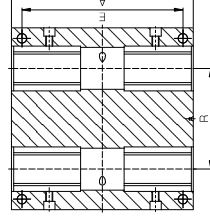
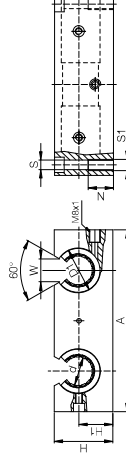

Please note:
Installation instructions
▶ Page 1079

Dimensions [mm]

d	D1	A	H	H1	W	R	N	E	S	S1	Part No. Standard with	Self-aligning with
12	22	85	30	18	14	42	13	73	5,3	M6	OQA-01-12	OJUM-03
16	26	100	35	22	17	54	13	88	5,3	M6	OQA-01-16	OQA-03-16
20	32	130	42	25	17	72	18	115	6,8	M8	OQA-01-20	OQA-03-20
25	40	160	51	30	21	88	22	140	9,0	M10	OQA-01-25	OQA-03-25
30	47	180	60	35	21	96	26	158	10,5	M12	OQA-01-30	OQA-03-30
40	62	230	77	45	27	122	34	202	13,5	M16	OQA-01-40	OQA-03-40

Are equipped with:



Available with drylin® liners (optional: J200/A180):



Closed, tandem design



Order key



Type	Option	Size
Tandem housing with RJUM bearings	Aluminum housing	Inner Ø
	Standard with RJUM-01	

- Housing: Aluminum, equipped with two drylin® R linear plain bearings to increase the guide length

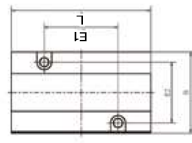
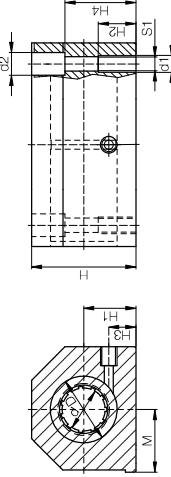

- Options:
- 01: Standard with RJUM-01
- 03: with RJUM-03
- 04: with RJUM-01

Please note:
Installation instructions
▶ Page 1079

Dimensions [mm]

d	D	H	H1	H2	H3	H4	S1	B	L	M	E1	E2	d1	d2	Part No.	Self-aligning bearings		Solid plastic bearings
																Standard with	with	
H6	+0,01	-0,02	+0,3	±0,02	±0,15	±0,15										RJUM-01	RJUM-03	RJM-01
8	16	28	13	13	8	23	M5	35	62	17,5	35	25	4,20	8	RTA-01-08	-		RTA-04-08
12	22	35	18	13	10	25	M6	43	76	21,5	40	30	5,20	10	RTA-01-12	RTA-03-12		RTA-04-12
16	26	42	22	13	12	30	M6	53	84	26,5	45	36	5,20	10	RTA-01-16	RTA-03-16		RTA-04-16
20	32	50	25	18	13	34	M8	60	104	30,0	55	45	6,80	11	RTA-01-20	RTA-03-20		RTA-04-20
25	40	60	30	22	15	40	M10	78	130	39,0	70	54	8,60	15	RTA-01-25	RTA-03-25		RTA-04-25
30	47	70	35	26	16	48	M12	87	152	43,5	85	62	10,30	18	RTA-01-30	RTA-03-30		RTA-04-30
40	62	90	45	34	20	60	M16	108	176	54,0	100	80	14,25	20	RTA-01-40	RTA-03-40		RTA-04-40

Are equipped with:



Available with drylin® liners (optional: J200/A180):



Open, tandem design



Order key



Type	Option	Size
Tandem housing with OJUM bearings	Aluminum housing	Inner Ø
	Standard with OJUM-01	

- Housing: Aluminum, equipped with two drylin® R linear plain bearings to increase the guide length

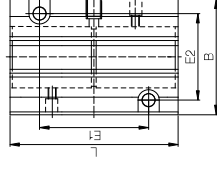
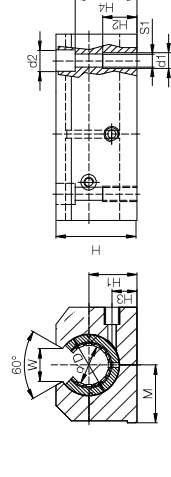

- Options:
- 01: Standard with OJUM-01
- 03: with OJUM-03

Please note:
Installation instructions
▶ Page 1079

Dimensions [mm]

d	D	H	H1	H2	H3	H4	S1	B	L	M	E1	E2	d1	d2	W	Part No.	Self-aligning	
																	Standard with	with
H6	+0,01	-0,02	+0,3	±0,02	±0,15	±0,15										OJUM-01	OJUM-03	
12	22	30	18	13	10	25	M6	43	76	21,5	40	30	5,20	10	14	OTA-01-12	OTA-03-12	
16	26	35	22	13	12	30	M6	53	84	26,5	45	36	5,20	10	17	OTA-01-16	OTA-03-16	
20	32	42	25	18	13	34	M8	60	104	30,0	55	45	6,80	11	17	OTA-01-20	OTA-03-20	
25	40	51	30	22	15	40	M10	78	130	39,0	70	54	8,60	15	21	OTA-01-25	OTA-03-25	
30	47	60	35	26	16	48	M12	87	152	43,5	85	62	10,30	18	21	OTA-01-30	OTA-03-30	
40	62	77	45	34	20	60	M16	108	176	54,0	100	80	14,25	20	27	OTA-01-40	OTA-03-40	

Are equipped with:



Available with drylin® liners (optional: J200/A180):



Closed, long design



Order key



Type	Option	Size
Linear housing with RJUM bearing	Aluminum housing	Inner Ø
	Standard with RJUM-01	
	03: with RJUM-03	
	04: with RJUM-01	

- Housing: Aluminium, equipped with drylin® R linear plain bearings

Options:
01: Standard with RJUM-01
03: with RJUM-03
04: with RJUM-01

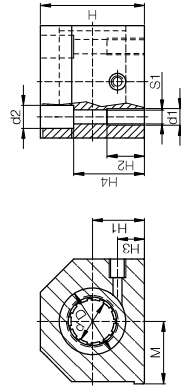

Please note:
Installation instructions
▶ Page 1079

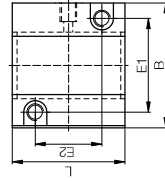

Dimensions [mm]

d	D	H	H1	H2	H3	H4	S1	B	L	M	E1	E2	d1	d2	Part No.	Self-aligning with	Solid plastic bearings with
H6	+0.01	-0.02	$\pm 0.3 \pm 0.02 \pm 0.15 \pm 0.15$														
8	16	28	13	10	8	14	M4	35	32	17.5	25	20	3.2	6	RG A-01-08	-	RG A-04-08
12	22	35	18	11	10	25	M5	43	39	21.5	32	23	4.2	6	RG A-01-12	RG A-03-12	RG A-04-12
16	26	42	22	13	12	30	M6	53	43	26.5	40	26	5.2	10	RG A-01-16	RG A-03-16	RG A-04-16
20	32	50	25	18	13	34	M8	60	54	30.0	45	32	6.8	11	RG A-01-20	RG A-03-20	RG A-04-20
25	40	60	30	22	15	40	M10	78	67	39.0	60	40	8.6	15	RG A-01-25	RG A-03-25	RG A-04-25
30	47	70	35	22	16	48	M10	87	79	43.5	68	45	8.6	15	RG A-01-30	RG A-03-30	RG A-04-30
40	62	90	45	26	20	60	M12	108	91	54.0	86	58	10.3	18	RG A-01-40	RG A-03-40	RG A-04-40

Are equipped with:



Available with drylin® liners (optional: J200/A180):



Open, long design



Order key



Type	Option	Size
Linear housing with OJUM bearing	Aluminum housing	Inner Ø
	Standard with OJUM-01	
	03: with OJUM-03	

- Housing: Aluminium, equipped with drylin® R linear plain bearings

Options:
01: Standard with OJUM-01
03: with OJUM-03

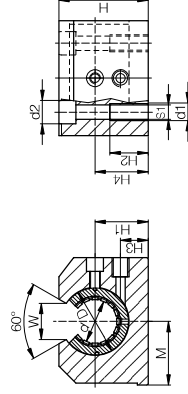

Please note:
Installation instructions
▶ Page 1079

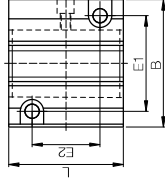

Dimensions [mm]

d	D	H	H1	H2	H3	H4	S1	B	L	M	E1	E2	d1	d2	W	Part No.	Self-aligning with	
H6	+0.01	-0.02	$\pm 0.3 \pm 0.02 \pm 0.15 \pm 0.15$												+0.6	Standard	OJUM-01	OJUM-03
12	22	28	18	11	8	25	M5	43	39	21.5	32	23	4.2	8	14	OG A-01-12	OG A-03-12	
16	26	35	22	13	12	30	M6	53	43	26.5	40	26	5.2	10	17	OG A-01-16	OG A-03-16	
20	32	42	25	18	13	34	M8	60	54	30.0	45	32	6.8	11	17	OG A-01-20	OG A-03-20	
25	40	51	30	22	15	40	M10	78	67	39.0	60	40	8.6	15	21	OG A-01-25	OG A-03-25	
30	47	60	35	22	16	48	M10	87	79	43.5	68	45	8.6	15	21	OG A-01-30	OG A-03-30	
40	62	77	45	26	20	60	M12	108	91	54.0	86	58	10.3	18	27	OG A-01-40	OG A-03-40	

Are equipped with:



Available with drylin® liners (optional: J200/A180):



drylin® R shaft guides | igus® testing method

igus® testing method for measuring the tolerance of drylin® linear plain bearings

To ensure the correct function of a drylin® linear plain bearing, it is necessary to use the bearing with a defined minimum oversize (bearing clearance). The quality control of this part is carried out with a plug gauge test. For this purpose, specific force is defined with which the plug gauge is loaded when the plain bearing is tested.

Part No.	Test force [N]	Ø test housing	Min. bearing Øi (plug gauge falls)	Max. bearing Øi (plug gauge sticks)
J / J200 / E7 / A180 / A160UM-01/02-10	0.981	12.000mm	10.030mm	10.070mm
J / J200 / E7 / A180 / A160UM-01/02-12	1.373	14.000mm	12.030mm	12.070mm
J / J200 / E7 / A180 / A160UM-01/02-16	1.864	18.000mm	16.030mm	16.070mm
J / J200 / E7 / A180 / A160UM-01/02-20	2.649	23.000mm	20.030mm	20.070mm
J / J200 / E7 / A180 / A160UM-01/02-25	3.729	28.000mm	25.030mm	25.070mm
J / J200 / E7 / A180 / A160UM-01/02-30	4.807	34.000mm	30.040mm	30.090mm
J / J200 / E7 / A180 / A160UM-01/02-40	7.063	44.000mm	40.040mm	40.090mm
J / J200 / E7 / A180 / A160UM-01/02-50	9.810	55.000mm	50.050mm	50.150mm
J / J200 / E7UM-01/02-60	13.047	65.000mm	60.050mm	60.150mm

JUI-01-06	0.981	0.4684in	0.3768in	0.3776in
JUI-01-08	1.373	0.5934in	0.5016in	0.5024in
JUI-01-10	1.864	0.7184in	0.6268in	0.6276in
JUI-01-12	2.649	0.8747in	0.7516in	0.7524in
JUI-01-16	3.729	1.1247in	1.0016in	1.0024in
JUI-01-20	4.807	1.4058in	1.2520in	1.2531in
JUI-01-24	7.063	1.6558in	1.5020in	1.5031in
JUI-01-32	9.810	2.1870in	2.0024in	2.0039in

RJM / RJMP / RJ4JP-01-08	-	16.000mm	8.025mm	8.061mm
RJM / RJMP / RJ4JP-01-10	-	19.000mm	10.025mm	10.061mm
RJM / RJMP / RJ4JP-01-12	-	22.000mm	12.032mm	12.075mm
RJM / RJMP / RJ4JP-01-16	-	26.000mm	16.032mm	16.075mm
RJM / RJMP / RJ4JP-01-20	-	32.000mm	20.040mm	20.092mm
RJM / RJMP / RJ4JP-01-25	-	40.000mm	25.040mm	25.092mm
RJM / RJMP / RJ4JP-01-30	-	47.000mm	30.040mm	30.092mm
RJM / RJMP-01-40	-	62.000mm	40.050mm	40.112mm

RJI-01-06	0.981	0.6250in	0.3762in	0.3776in
RJI-01-08	1.373	0.8750in	0.5013in	0.5030in
RJI-01-10	1.864	1.1250in	0.6265in	0.6282in
RJI-01-12	2.649	1.2500in	0.7516in	0.7536in
RJI-01-16	3.729	1.5625in	1.0035in	1.0056in
RJI-01-20	4.807	2.0000in	1.2520in	1.2544in
RJI-01-24	7.063	2.3750in	1.5020in	1.5044in
RJI-01-32	9.810	3.0000in	2.0024in	2.0053in

RJ260(U)M-02-12	-	19.000mm	12.032mm	12.084mm
RJ260(U)M-02-16	-	24.000mm	16.032mm	16.084mm
RJ260(U)M-02-20	-	28.000mm	20.040mm	20.100mm
RJ260(U)M-02-25	-	35.000mm	25.040mm	25.100mm

drylin® R shaft guides | igus® testing method

Part No.	Test force [N]	Ø test housing	Min. bearing Øi (plug gauge falls)	Max. bearing Øi (plug gauge sticks)
XUMO-01-10	0.981	12.000mm	9.98mm	10.02mm
XUM-01/02-12	1.373	14.000mm	12.02mm	12.06mm
XUM-01-14	1.500	16.000mm	14.02mm	14.06mm
XUM-01/02-16	1.864	18.000mm	16.02mm	16.06mm
XUM-01/02-20	2.649	23.000mm	20.03mm	20.07mm
XUM-01/02-25	3.729	28.000mm	24.97mm	25.01mm
XUM-01/02-30	4.807	34.000mm	29.96mm	30.01mm
XUM-01/02-40	7.063	44.000mm	40.00mm	40.05mm

Explanation:

The iglidur® X material has a higher stiffness than iglidur® J. This causes shifts – depending on the diameter – compared to the ratio of test force to LD diameter. The parts are designed in such a way that under load the clearance between the iglidur® X and iglidur® J plain bearings is as identical as possible. Thereby in the use of iglidur® X liners, increased shifting forces can occur in the unloaded new condition on an h-toleranced shaft.

When using a plain bearing (e.g. JUM/RJM) in connection with an adapter/ housing (e.g. RJUM, OJUM, RGA) the factory tolerance of the housing hole (standard case: H7) is also added to the minimum clearance stated above. The total from these two values then produces the maximum possible bearing tolerance.

The effective bearing clearance is also influenced by the shaft tolerance. The maximum shaft undersize value should be added to give the maximum possible clearance.

F_{max} dynamic:

The maximum values are the result of the projected surface and 5MPa surface pressure.

F_{max} static:

The maximum values are the result of the projected surface and 35MPa surface pressure.

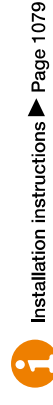

Tightening torque for drylin® connections between metal parts

Metric thread (Da)	Tightening torque [Nm]	Recommended tightening torque [Nm]
M3	0.5–1.1	0.7
M4	1.0–2.8	1.5
M5	2.0–5.5	3.0
M6	4.0–10.0	6.0
M8	8.0–23.0	15.0
M10	22.0–46.0	30.0

Please be aware of the minimal screw-in depth for aluminium and zinc die-casting parts: 1.5 x Da

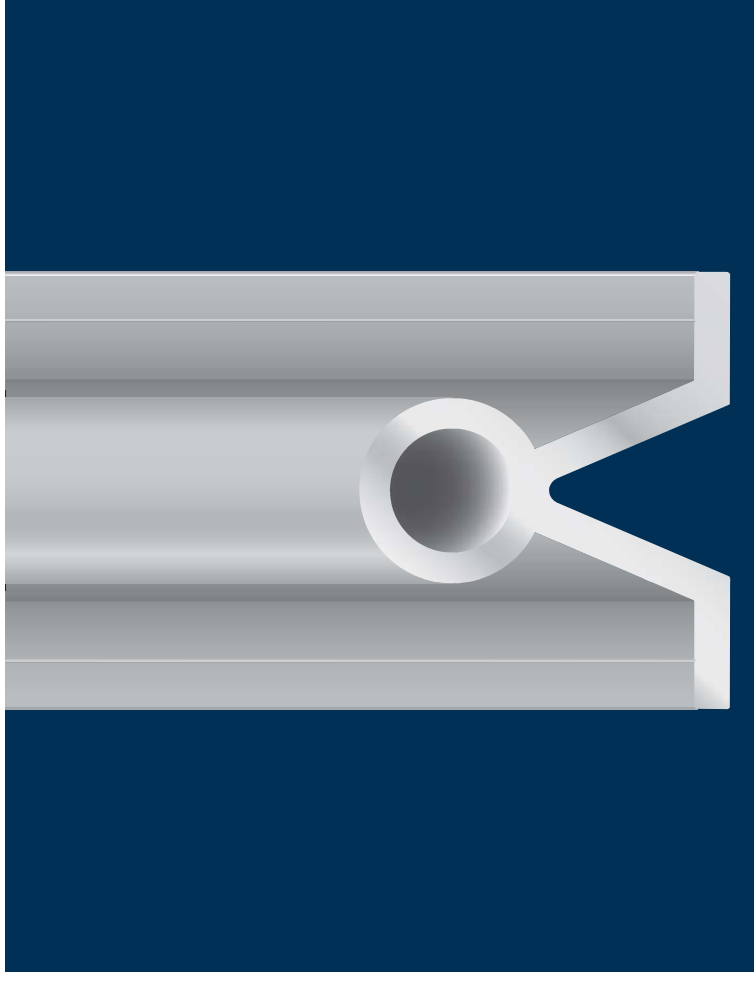
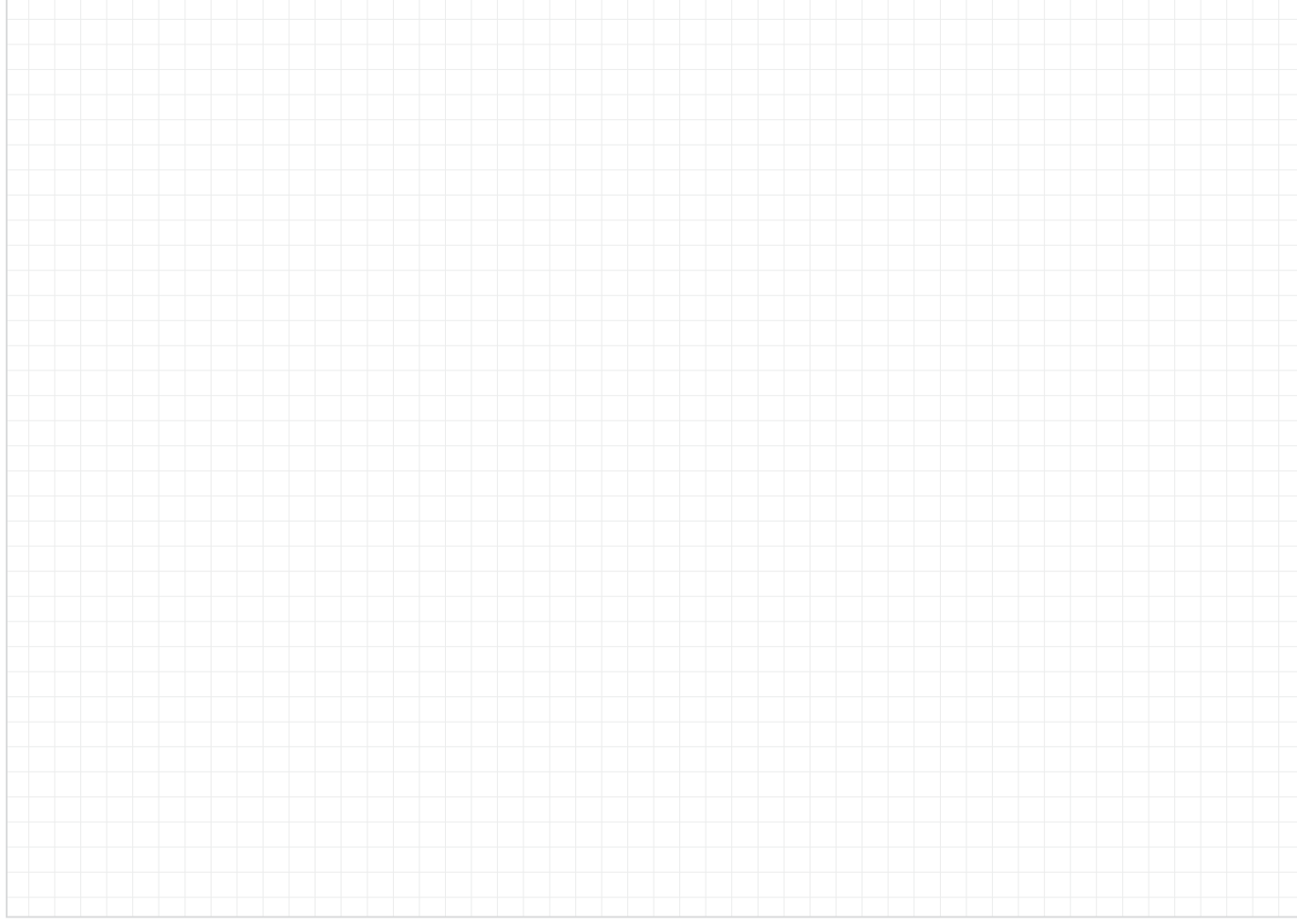

drylin[®] linear technology – drylin[®] shafts

Hard-anodised aluminium shafts for optimum running performance

Stainless steel for high corrosion resistance

Hardened steel and stainless steel shafts

Carbon fibre shafts

Round shafts with or without support



Suitable liner materials:

					
Potential counter partner	The all-rounder - iglidur® J	The specialist - iglidur® J200	The extreme - iglidur® X	The FDA-compliant - iglidur® A180	Blue Sky Thinking FDA/VEU-compliant iglidur® A160
Application temperature	All shaft materials from -50°C to +90°C	Hard-anodised aluminium from -50°C to +90°C	Hardened stainless steel from -100°C to +250°C	All shaft materials from -50°C to +90°C	Stainless steel from -50°C to +90°C
Best coefficient of friction with	Steel shaft	Hard-anodised aluminium	Hard-chromed steel	Stainless steel shaft	Hardened stainless steel shafts
Maximum service life with	Hard-anodised aluminium	Hard-anodised aluminium	Hardened stainless steel	Stainless steel shaft	Hardened stainless steel shafts
Permissible stat. surface pressure	35MPa	23MPa	150MPa	28MPa	15MPa
Moisture absorption	1.3% weight	0.7% weight	0.5% weight	< 0.1% weight	< 0.1% weight
Volume resistance	> 10 ¹⁰ Ocm	> 10 ¹⁰ Ocm	< 10 ¹⁰ Ocm	> 10 ¹⁰ Ocm	> 10 ¹⁰ Ocm
More information	▶ Page 159	▶ Page 261	▶ Page 279	▶ Page 401	▶ Page 419

Available shaft materials:

- | | | |
|---|--|--|
| <p>Aluminium</p> <ul style="list-style-type: none"> ● Ideal in combination with liners made from iglidur® J/J200 ● Lightweight ● Low wear ● Corrosion-free ● Available from stock | <p>Stainless steel</p> <ul style="list-style-type: none"> ● E7 liners for up to 8 times longer service life ● Cost-effective standard ● High load capacity ● Dry area applications ● Hard chrome-plated also available ● Lower coefficient of friction against plastic bearings | <p>Stainless steel</p> <ul style="list-style-type: none"> ● A180 liners for food and pharmaceutical applications ● Corrosion resistance ● High chemical resistance ● Ideal solution for wet applications ● 316 stainless steel for extremely chemical intensive applications |
|---|--|--|



Please remember that this is a technical surface. Small colour variations are possible due to variable coating depths.



iglidur J against particular shaft materials



iglidur J against particular shaft materials

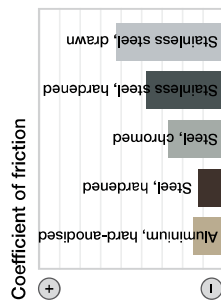

iglidur J against particular shaft materials



iglidur J against particular shaft materials

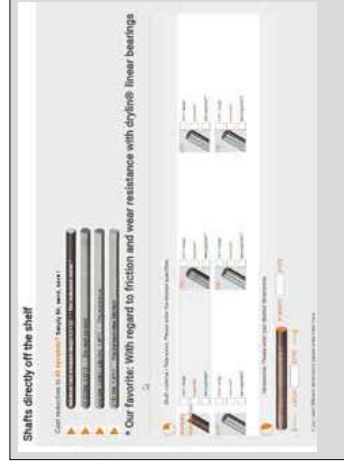

Inquiries can be put online as well:

▶ www.igus-asean.com/shaftinquiry

Special machining

All shafts can be individually machined. Please send us your drawing. We can then provide a quotation quickly.

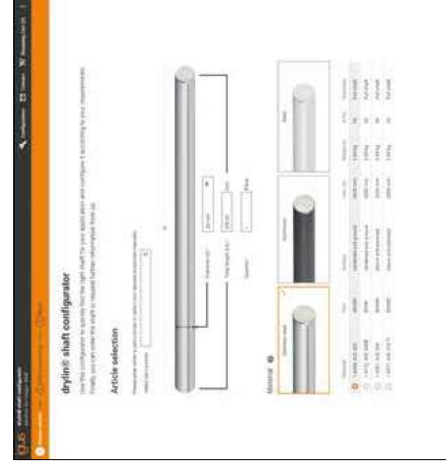

Configurator for guide shafts; guide shafts with machining – anyone can configure online

With this online tool, guide shafts with and without machining can be individually configured and ordered. Fast and easy with no previous CAD experience. All in all, the tool makes it possible to order 7 shaft materials from Ø 6 to 50mm. Order online, delivered quickly,

- Add chamfers with just one click
- Offset machined end possible
- Radial and axial holes, with or without female thread
- With plausibility check
- Live price display

▶ www.igus-asean.com/shaft-configurator

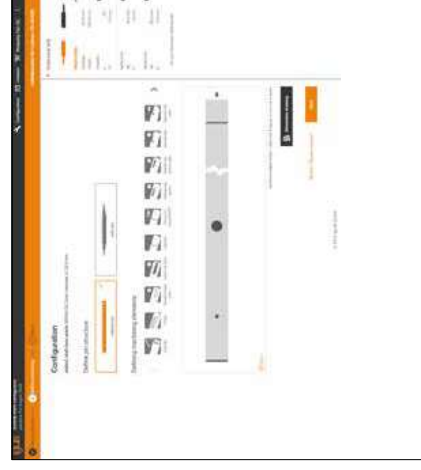

drylin® shafts | Product range

Material	Aluminium				Steel				
	AWMP AWMPV	AWMU	AWMR	AWMH	SWUM SWUMN	SWM	SWMH	SWUMH SWUMHN	
Designation	EN AW 6061/6060				AISI 1055				1.1213 HV
Material	EN AW 6061/6060				AISI 1055				1.1213 HV
Availability									
Ø 6	●		▲	▲		▲	▲	▲	
Ø 8	●		▲	▲		▲	▲	▲	
Ø 10	●	●	▲	▲		▲	▲	▲	
Ø 12	●	●	●	▲	▲	▲	▲	▲	
Ø 16	●	●	●	▲	▲	▲	▲	▲	
Ø 20	●	●	●	▲	▲	▲	▲	▲	
Ø 25	●	●	●	▲	▲	▲	▲	▲	
Ø 30	● ⁽⁶⁴⁾ / ●	●	▲	▲	▲	▲	▲	▲	
Ø 40	● ⁽⁶⁴⁾ / ●	●	▲	▲	▲	▲	▲	▲	
Ø 50	● ⁽⁶⁴⁾ / ●	●	▲	▲	▲	▲	▲	▲	
Ø 60	● ⁽⁶⁴⁾ / ●	●	▲	▲	▲	▲	▲	▲	
Ø Tolerance									
	h8	-0,1mm	h9	h6	h6	h6	h7	h7	
Max. supply length Ø 8–10mm									
	3,000	-	-	3,000	-	-	-	3,000	
Max. supply length Ø 12–50mm									
	3,000	4,000	3,000	6,000	6,000	6,000	6,000	6,000	
Surface									
	hard-anodised				hardened/ground				hard chromed
Surface roughness Ra									
	< 0.6				0.15–0.3				
Hardness									
	up to 550 HV				60+4 HRC				
Roundness									
	≤ 1/2 Ø Tolerance				≤ 1/2 Ø Tolerance				

Delivery time: ● From stock ▲ simply cut shafts 3–8 days; machined shafts 12 days
⁽⁶⁴⁾ Hollow profile 30 · 7.5; 40 · 10; 50 · 11

Material	Stainless steel, hardened				Drawn stainless steel				Carbon fibre	
	EWM EWUMN	EWM EWUMN	EEWUM EEWUMN	EWUM EWUMN	EWMR	EWMS	EWUMS	EWUMS		
Material	AISI 440B				AISI 304				AISI 316Ti	CFK Composite
Availability										
Ø 6	▲		▲	▲	▲	▲	▲	▲		
Ø 8	▲		▲	▲	▲	▲	▲	▲		
Ø 10	▲		▲	▲	▲	▲	▲	▲		
Ø 12	▲	▲	▲	▲	▲	▲	▲	▲	▲	
Ø 16	▲	▲	▲	▲	▲	▲	▲	▲	▲	
Ø 20	▲	▲	▲	▲	▲	▲	▲	▲	▲	
Ø 25	▲	▲	▲	▲	▲	▲	▲	▲	▲	
Ø 30	▲	▲	▲	▲	▲	▲	▲	▲	▲	
Ø 40	▲	▲	▲	▲	▲	▲	▲	▲	▲	
Ø 50	▲	▲	▲	▲	▲	▲	▲	▲	▲	
Ø 60	▲	▲	▲	▲	▲	▲	▲	▲	▲	
Ø Tolerance										
	h6	h6	h6	h6	h9	h9	h9	h9	-0,1mm	
Max. supply length Ø 8–10mm										
	-	-	3,000	-	-	-	-	-	2,000	
Max. supply length Ø 12–50mm										
	6,000	6,000	6,000	6,000	3,000	3,000	3,000	3,000	2,000	
Surface										
	hardened/ground				drawn, polished				UCU unidirectional/ cross winding/ unidirectional	
Surface roughness Ra										
	0.15–0.3				0.3–0.6				< 0.6µm	
Hardness										
	52+8 HRC				soft				-	
Roundness										
	≤ 1/2 Ø Tolerance				≤ 1/2 Ø Tolerance				± 0.05mm	



AWMR AWMR

Order key

Type	Size	Options
Aluminium shaft	AWM P - 06 - 2000	AWMP: Solid shaft up to Ø 25mm Hollow shaft from Ø 30mm AWMR: Tube
Metric		Shaft length [mm]
Precise		Outer Ø

- !** **igus® recommendation:** Linear plain bearings equipped with **iglidur® J2000** liners for the longest service life

i **Hard-anodised surfaces**
 ▶ Page 958
 Minimum saw lengths
 ▶ Page 961

- Material: EN AW 6061/6060
- Straightness: EN 754-3
- Hardness: 75 HB
- Surface: hard-anodised
- Hardness: up to 550 HV
- Imperial shafts available upon request

Computer **Please contact us!**
 drylin® shafts can be individually machined. Please send us your drawing or configure online. We can then provide a quotation quickly.
 ▶ www.igus-asean.com/shaft-configurator

Dimensions [mm]

Part No.	Design	Outer Ø	Tolerance	Insulation thickness	Inner Ø	Max. length	Weight [kg/m]
AWMP-06	Solid shaft	6	h8	-	-	3,000	0.08
AWMP-08	Solid shaft	8	h8	-	-	3,000	0.14
AWMP-10	Solid shaft	10	h8	-	-	3,000	0.22
AWMP-12	Solid shaft	12	h8	-	-	3,000	0.32
AWMR-12	Tube	12	h8	2	8	3,000	0.17
AWMP-16	Solid shaft	16	h8	-	-	3,000	0.56
AWMR-16	Tube	16	h8	2	12	3,000	0.25
AWMP-20	Solid shaft	20	h8	-	-	3,000	0.88
AWMR-20	Tube	20	h9	2	16	3,000	0.32
AWMP-25	Solid shaft	25	h8	-	-	3,000	1.37
AWMR-25	Tube	25	h9	3	19	3,000	0.59
AWMP-30	Hollow shaft	30	h8	7.5	15	3,000	1.48
AWMPV-30	Solid shaft	30	h8	-	-	3,000	1.9
AWMP-40	Hollow shaft	40	h8	10	20	3,000	2.63
AWMPV-40	Solid shaft	40	h8	-	-	3,000	3.4
AWMP-50	Hollow shaft	50	h8	11	28	3,000	3.75
AWMP-60	Hollow shaft	60	h8	11	38	3,000	4.7



Order example: AWMP-12-500: Precision aluminium shaft, 12mm Ø, 500mm length



AWMU

Order key

Type	Size	Options
Aluminium shaft	AWM U - 12 - 2000	Supported Metric Shaft length [mm]
Metric		Outer Ø

i **Hard-anodised surfaces**
 ▶ Page 958
 Minimum saw lengths
 ▶ Page 961

- Material: EN AW 6061/6060
- Straightness: DIN 12020
- Hardness: 75 HB
- Surface: hard-anodised
- Hardness: up to 550 HV
- Symmetrical standard hole pattern C5 = C6

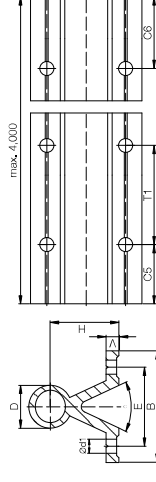

Dimensions [mm]

Part No.	D	B	H	V	d1	°	E	T1	C5/C6	Min.	Max. length	Max. length [kg/m]	Iy [mm ⁴]	Iz [mm ⁴]	Wby [mm ³]	Wbz [mm ³]	
AWMU-12	12	40	22	5	4.5	50	±0.25	29	75	20	57	4,000	0.75	26,600	19,700	1,330	1,091
AWMU-16	16	45	26	5	5.5	50		33	100	20	69	4,000	1.00	40,000	39,200	1,778	1,844
AWMU-20	20	52	32	6	6.6	50		37	100	20	69	4,000	1.42	76,600	86,200	2,946	3,336
AWMU-25	25	57	36	6	6.6	50		42	120	20	79	4,000	1.81	109,800	146,700	3,853	5,103
AWMU-30	30	69	42	7	9.0	50		51	150	20	94	4,000	2.69	226,900	328,700	6,577	10,049
AWMU-40 ⁸⁹⁾	40	73	50	8	9.0	50		55	200	20	119	4,000	4.06	382,100	734,800	10,468	19,160

⁸⁹⁾ The tolerance for the shaft diameter D amounts **-0.15**



Order example: AWMU-16-500: supported aluminium shaft, 16mm Ø, 500mm length



igus® recommendation: Linear plain bearings equipped with iglidur® E7 liners for 8 times longer service life



Please contact us!
drylin® shafts can be individually machined. Please send us your drawing or configure online. We can then provide a quotation quickly.
► www.igus-asean.com/shaft-configurator

Dimensions [mm] – hardened stainless steel AISI 440B

Part No.	Outer Ø	Weight [kg/m]	Max. length	Effective hardness depth
EWM-06	6	0,222	3,000	0,8
EWM-08	8	0,359	4,000	0,9
EWM-10	10	0,617	4,000	0,9
EWM-12	12	0,888	6,000	1,0
EWM-16	16	1,578	6,000	1,2
EWM-20	20	2,466	6,000	1,6
EWM-25	25	3,853	6,000	1,8
EWM-30	30	5,549	6,000	2,0
EWM-40	40	9,865	6,000	2,2
EWM-50	50	15,413	6,000	2,4



Order key

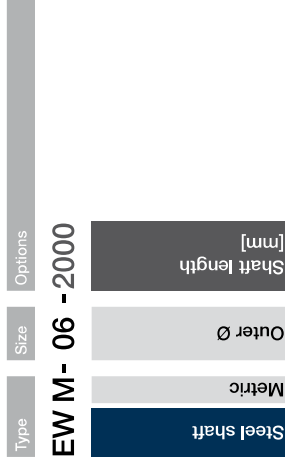

Available shaft materials

AISI 440B, hardened/ground ► EWM
 AISI 420C, hardened/ground ► EEW
 AISI 304, drawn ► EWMR
 AISI 316Ti, drawn ► EWMS

Dimensions [mm] – hardened stainless steel AISI 420C

Part No.	Outer Ø	Weight [kg/m]	Max. length	Effective hardness depth
EEWM-06	6	0,222	3,000	0,8
EEWM-08	8	0,359	4,000	0,9
EEWM-10	10	0,617	4,000	0,9
EEWM-12	12	0,888	6,000	1,0
EEWM-16	16	1,578	6,000	1,2
EEWM-20	20	2,466	6,000	1,6
EEWM-25	25	3,853	6,000	1,8
EEWM-30	30	5,549	6,000	2,0
EEWM-40	40	9,865	6,000	2,2
EEWM-50	50	15,413	6,000	2,4

Dimensions [mm] – stainless steel AISI 304 (EWMR) or AISI 316Ti soft stainless steel (EWMS)

Part No.	Outer Ø	Weight [kg/m]	Max. length
EWMR-06	6	0,222	3,000
EWMR-08	8	0,359	3,000
EWMR-10	10	0,617	3,000
EWMR-12	12	0,888	3,000
EWMR-16	16	1,578	3,000
EWMR-20	20	2,466	3,000
EWMR-25	25	3,853	3,000
EWMR-30	30	5,549	3,000
EWMR-40	30	5,549	3,000
EWMR-50	30	5,549	3,000



Order example:

EWM-16-500: Stainless steel shaft (AISI 440B) with 16mm Ø, 500mm in length



EWUM

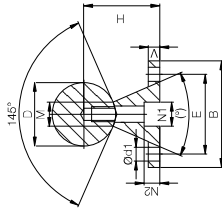

- igus® recommendation: Linear plain bearings equipped with iglidur® E7 liners for 8 times longer service life
- Completely supported and mounted with standard aluminum support
- For supported shafts:
 - Shaft support supplied in lengths of 600mm max.
 - Standard pitch T2, T1 also possible upon request
 - Symmetrical hole pitches C5 = C6

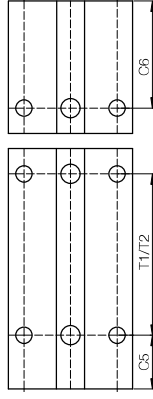

EWUMN

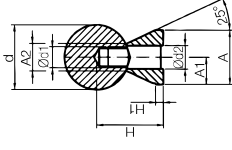

Order key

Type	Size	Options
EWUMN- 20 -2000-T1	Outer Ø	Shaft length [mm] Hole pattern

Low level supported stainless steel shaft.

EWUM: Supported stainless steel shaft
EWUMN: Low level supported stainless steel shaft

Available materials and lengths:
AISI 440B, max. 6.000mm

Hole pattern:
T2: T2 pitch (standard)
T1: T1 pitch (upon request)

Dimensions [mm] – supported stainless steel shafts AISI 440B

Part No.	D	B	H	V	N1	N2	d1	M	E	T1		C5/C6	T2	C5/C6		Weight	
										Min.	Max.			Min.	Max.		
										±0.15	±0.15						
EWUM-12	12	40	22	5	8.0	5.0	4.5	5.8	50	29	75	20	57	120	20	79	1.75
EWUM-16	16	45	26	5	9.5	6.0	5.5	7.0	50	33	100	20	69	150	20	94	2.64
EWUM-20	20	52	32	6	11.0	6.5	6.6	8.3	50	37	100	20	69	150	20	94	3.97
EWUM-25	25	57	36	6	14.0	8.5	6.6	10.8	50	42	120	20	79	200	20	119	5.65
EWUM-30	30	69	42	7	17.0	10.5	9.0	11.0	50	51	150	20	94	200	20	119	7.93
EWUM-40	40	73	50	8	17.0	10.5	9.0	15.0	50	55	200	20	119	300	20	169	12.88
EWUM-50	50	84	60	9	19.0	12.5	11.0	19.0	46	63	200	20	119	300	20	169	19.60



Order example:
EWUM-16-500-T1: Supported stainless steel shaft (AISI 440B) with 16mm outer Ø 500mm length, T1 pitch

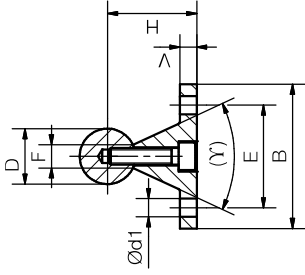

Order example:
EWUMN-16-500: Low level supported stainless steel shaft (AISI 440B) with 16mm outer Ø, 500mm length

EWUM-ES/
EWUMS-ES

! igus® recommendation: Linear plain bearings equipped with iglidur® E7 liners for 8 times longer service life

Standard shaft support blocks made of stainless steel

- Connection sizes are identical to aluminium supports

► Page 1160

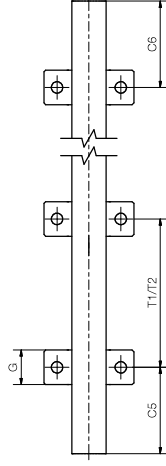

Order key

Type	Size	Options
Partially supported stainless steel shaft, metric	Outer Ø	Hole pattern
EWUMS-ES- 20 -500 -T2	Shaft length [mm]	

Available materials and lengths:

AISI 440B, max. 6.000mm

▲ EWUM

AISI 316Ti, max. 3.000mm

▲ EWUMS

Options:

Blank: AISI 440B material

S: AISI 316Ti

Hole pattern:

T2: T2 pitch (standard)

T1: T1 pitch

Dimensions [mm] – partially supported stainless steel shafts AISI 440B

Part No.	D h6	B	H	V	d1	E	γ	F	G	T1	C5/C6 for T1		T2 Standard	C5/C6 for T2	
											Min.	Max.		Min.	Max.
EWUM-ES-12	12	40	22	5	4,5	29	-	5,8	14	75	20	57	120	20	79
EWUM-ES-16	16	45	26	5	5,5	33	-	7,0	16	100	20	69	150	20	94
EWUM-ES-20	20	52	32	6	6,6	37	50°	8,3	20	100	20	69	150	20	94
EWUM-ES-25	25	57	36	6	6,6	42	-	10,8	25	150	20	79	200	20	119
EWUM-ES-30	30	69	42	7	9,0	51	-	11,0	25	150	20	94	200	20	119
EWUM-ES-40	40	73	50	8	9,0	55	-	15,0	25	200	20	119	300	20	169



Order example:

EWUM-ES-20-500, partially supported stainless steel shaft (shaft and support made of stainless steel),

AISI 440B material, T2 pitch, outer Ø 20mm, L = 500mm

Dimensions [mm] – partially supported stainless steel shafts AISI 316Ti

Part No.	D h6	B	H	V	d1	E	γ	F	G	T1	C5/C6 for T1		T2 Standard	C5/C6 for T2	
											Min.	Max.		Min.	Max.
EWUMS-ES-12	12	40	22	5	4,5	29	-	5,8	14	75	20	57	120	20	79
EWUMS-ES-16	16	45	26	5	5,5	33	-	7,0	16	100	20	69	150	20	94
EWUMS-ES-20	20	52	32	6	6,6	37	50°	8,3	20	100	20	69	150	20	94
EWUMS-ES-25	25	57	36	6	6,6	42	-	10,8	25	150	20	79	200	20	119
EWUMS-ES-30	30	69	42	7	9,0	51	-	11,0	25	150	20	94	200	20	119
EWUMS-ES-40	40	73	50	8	9,0	55	-	15,0	25	200	20	119	300	20	169



Order example:

EWUM-ES-20-500, partially supported stainless steel shaft (shaft and support made of stainless steel),

AISI 316Ti material, T1 pitch, outer Ø 20mm, L = 500mm

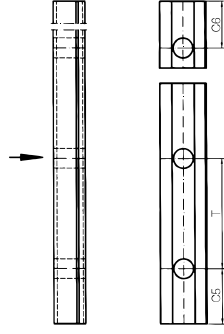
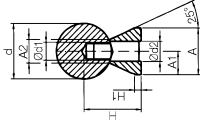
EWUMN-ES/
EWUMSN-ES

! igus® recommendation: Linear plain bearings equipped with iglidur® E7 liners for 8 times longer service life

Low level shaft support blocks made of stainless steel
 ● Connection sizes are identical to low-level aluminium supports ► [Page 1161](#)



Order key

Type	Size	Options
EWUMSN-ES- 20 -500-T2	Outer Ø	Shaft length [mm] Hole pattern
Partially supported, stainless steel shaft, metric	Material	

Available materials and lengths:

▲ AISI 440B, max. 6,000mm

▲ EWUMN

▲ AISI 316Ti, max. 3,000mm

▲ EWUMSN

Dimensions [mm] – low level partially supported stainless steel shafts AISI 440B

Part No.	d	H	H1	A	A1	A2	d1	d2	T	C5/C6		Weight [kg/m]
										Min.	Max.	
EWUMN-ES-12	12	14.5	3	11	5.5	5.4	M4	4.2	75	20	57.0	1.00
EWUMN-ES-16	16	18.0	3	14	7.0	7.0	M5	5.2	75	20	57.0	1.76
EWUMN-ES-20	20	22.0	3	17	8.5	8.1	M6	6.2	75	20	57.0	2.77
EWUMN-ES-25	25	26.0	3	21	10.5	10.3	M8	8.2	75	20	57.0	4.35
EWUMN-ES-30	30	30.0	3	23	11.5	11.0	M10	10.2	100	20	69.5	6.01
EWUMN-ES-40	40	39.0	4	30	15.0	15.0	M12	12.5	100	20	69.5	10.80

Low-level partially supported stainless steel shafts are supplied unassembled

Dimensions [mm] – low level partially supported stainless steel shafts AISI 316Ti

Part No.	d	H	H1	A	A1	A2	d1	d2	T	C5/C6		Weight [kg/m]
										Min.	Max.	
EWUMSN-ES-12	12	14.5	3	11	5.5	5.4	M4	4.2	75	20	57.0	1.00
EWUMSN-ES-16	16	18.0	3	14	7.0	7.0	M5	5.2	75	20	57.0	1.76
EWUMSN-ES-20	20	22.0	3	17	8.5	8.1	M6	6.2	75	20	57.0	2.77
EWUMSN-ES-25	25	26.0	3	21	10.5	10.3	M8	8.2	75	20	57.0	4.35
EWUMSN-ES-30	30	30.0	3	23	11.5	11.0	M10	10.2	100	20	69.5	6.01
EWUMSN-ES-40	40	39.0	4	30	15.0	15.0	M12	12.5	100	20	69.5	10.80

Low-level partially supported stainless steel shafts are supplied unassembled



Order example:

EWUMN-ES-20-500: Low level partially supported stainless steel shafts, AISI 440B material, T2 pitch (standard), 20mm outer Ø, 500mm length



Order example:

EWUMSN-ES-20-500-T2: Low-level partially supported stainless steel shaft, AISI 316Ti material, T2 pitch, outer Ø 20mm, length 500mm



CWM

- Material: CFK composite
- Roundness tolerance: $\pm 0.05\text{mm}$
- Diameter tolerance: -0.1mm
- Application temperature: max. $+80^\circ\text{C}$
- Colour: Black



Order key

Type	Size	Options
Carbon fibre shaft	CWM- 12 - 1000	Shaft length [mm]
Metric		Outer Ø



Order key

Type	Size
Shaft end support, floating	TA - 08
	Inner Ø

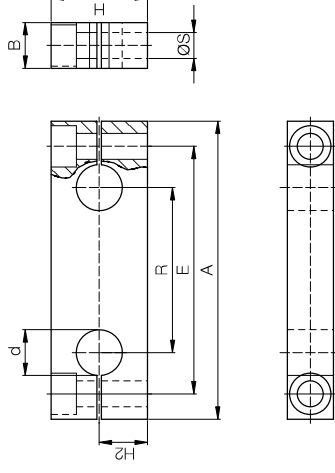

 Material: aluminium
Threaded fixing hole

Dimensions [mm]

Part No.	Design	Outer Ø	Inner Ø	Max. length	Weight [g]
CWM-12	Hollow shaft	-0.1	9.0	2,000	70
CWM-16	Hollow shaft	16	12.5	2,000	120
CWM-20	Hollow shaft	20	16.0	2,000	170
CWM-30	Hollow shaft	30	26.0	2,000	270



Order example:

CWM-16-500: Carbon fibre shaft, 16mm outer Ø, 500mm length

Dimensions [mm]

Part No.	d	A	B	H	H2	Ø S	E	R	Weight [g]
TA-08	8	65	12	22	11	M5	52	32	40
TA-10	10	70	12	21	10.5	M5	55	34	37
TA-12	12	85	14	28	14	M6	70	42	70
TA-16	16	100	18	32	16	M8	82	54	130
TA-20	20	130	20	42	21	M10	108	72	220
TA-25	25	160	25	52	26	M12	132	88	440
TA-30	30	180	25	58	29	M12	150	96	560
TA-40	40	230	30	72	36	M16	190	122	1,000



Order example:

TA-10: floating shaft end support with inner Ø 10mm

Shaft end supports, fixed



Order key

Type	Size
Fixed	Inner Ø
Shaft end support	
TAF - 08	

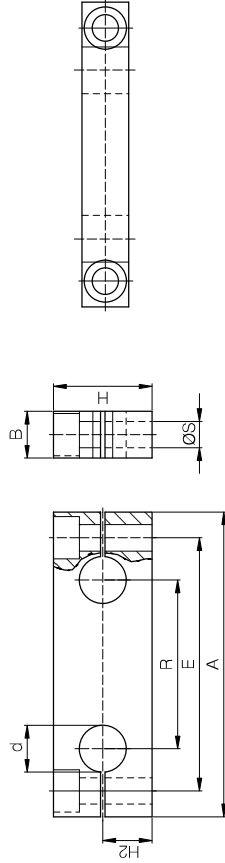
 Material: aluminium
Through fixing hole

Dimensions [mm]

Part No.	d	A	B	H	H2	Ø S	E	R	Weight [g]
TAF-08	8	65	12	23	12,5	5,5	52	32	40
TAF-10	10	70	12	25	14,0	5,5	55	34	45
TAF-12	12	85	14	32	18,0	6,6	70	42	90
TAF-16	16	100	18	36	20,0	9,0	82	54	140
TAF-20	20	130	20	46	25,0	11,0	108	72	250
TAF-25	25	160	25	56	30,0	13,5	132	88	470
TAF-30	30	180	25	64	35,0	13,5	150	96	620
TAF-40	40	230	30	80	44,0	17,5	190	122	1,150

Order example:

TAF-12: fixed shaft end support with 12mm inner Ø

Shaft end blocks, standard design



Order key

Type	Size
Standard design	Inner Ø
Shaft end block	
WA - 08	

Material: aluminium

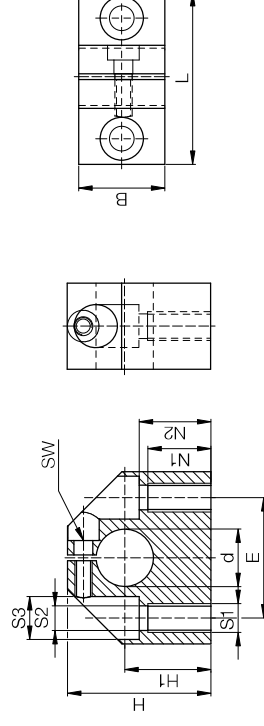

Dimensions [mm]

Part No.	d	B	H	H1	L	S1	S2	S3	E	N1	N2	SW	Weight [g]
WA-08	8	18	28	15	32	M4	3,3	6	22	9	13,0	2,5	40
WA-12	12	20	35	20	43	M6	5,2	10	30	13	16,5	3,0	100
WA-16	16	24	42	25	53	M8	6,8	11	38	18	21,0	4,0	150
WA-20	20	30	50	30	60	M10	8,6	15	42	22	25,0	5,0	230
WA-25	25	38	60	35	78	M12	10,3	18	56	26	30,0	6,0	410
WA-30	30	40	70	40	87	M12	10,3	18	64	26	34,0	6,0	530
WA-40	40	48	90	50	108	M16	14,25	20	82	34	44,0	8,0	990
WA-50	50	58	105	60	132	M20	17,5	26	100	43	49,0	10,0	1,250
WA-60	60	74	130	75	164	M27	22	33	124	43	59,0	10,0	2,950

Order example:

WA-08: shaft end block, standard design with inner Ø 8mm



Order key

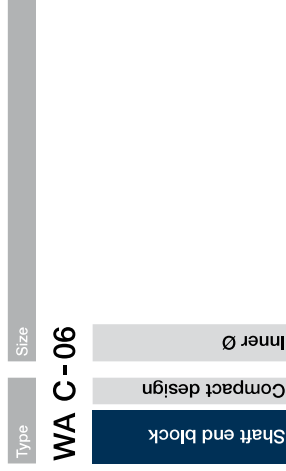

Material: aluminium

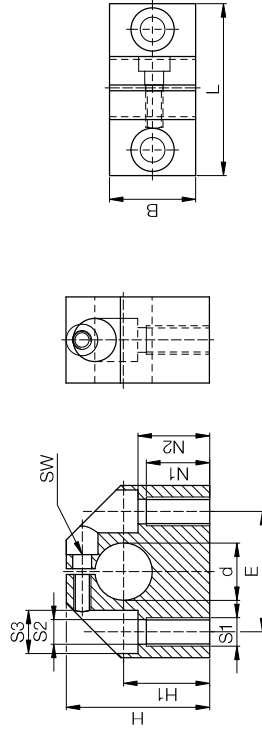

Dimensions [mm]

Part No.	d	B	H	H1	L	S1	S2	S3	E	N1	N2	SW	Weight [g]
WAC-06	6	16	27	15	32	M5	4,2	8	22	11	13	2,5	30
WAC-08	8	16	27	16	32	M5	4,2	8	22	11	13	2,5	30
WAC-10	10	18	33	18	40	M6	5,2	10	27	13	16	3,0	50
WAC-12	12	18	33	19	40	M6	5,2	10	27	13	16	3,0	50
WAC-14	14	20	38	20	45	M6	5,2	10	32	13	18	3,0	70
WAC-16	16	20	38	22	45	M6	5,2	10	32	13	18	3,0	70
WAC-20	20	24	45	25	53	M8	6,8	11	39	18	22	4,0	120
WAC-25	25	28	54	31	62	M10	8,6	15	44	22	26	5,0	170
WAC-30	30	30	60	34	67	M10	8,6	15	49	22	29	5,0	220
WAC-40	40	40	76	42	87	M12	10,3	18	66	26	38	6,0	480
WAC-50	50	50	92	50	103	M16	14,25	20	80	34	46	8,0	820



Order example:

WAC-12: shaft end block, compact design with inner Ø 12mm



Order key

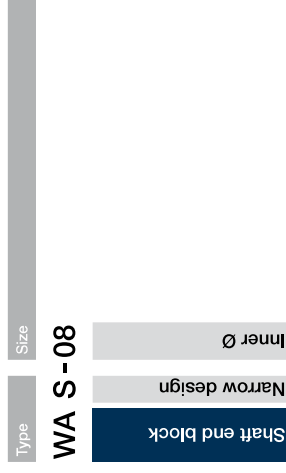

Material: aluminium

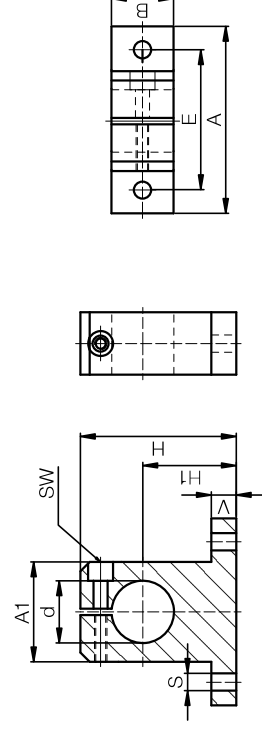

Dimensions [mm]

Part No.	d	H	H1	A	A1	B	E	S	V	SW	Weight [g]
WAS-08	8	27	15	32	16	10	25	4,5	5,0	2,5	12
WAS-12	12	35	20	42	20	12	32	5,5	5,5	3,0	23
WAS-16	16	42	25	50	26	16	40	5,5	6,5	3,0	35
WAS-20	20	50	30	60	32	20	45	5,5	8,0	4,0	67
WAS-25	25	58	35	74	38	25	60	6,6	9,0	4,0	140
WAS-30	30	68	40	84	45	28	68	9,0	10,0	5,0	200
WAS-40	40	86	50	108	56	32	86	11,0	12,0	6,0	480



Order example:

WAS-12: shaft end block, narrow design with inner Ø 12mm



Type: **WA F - 12**

Size: **Inner Ø**

With flange: **Shaft end block**



Material: aluminium

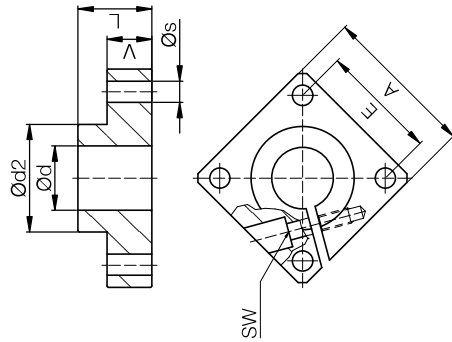

Dimensions [mm]

Part No.	Ø d	A	L	Ø d2	E	Ø s	V	SW	Weight [kg]
WAF-12	12	40	20	23,5	30 ± 0,12	5,5	12	3	60
WAF-16	16	50	20	27,5	35 ± 0,12	5,5	12	3	80
WAF-20	20	50	23	33,5	38 ± 0,15	6,6	14	4	100
WAF-25	25	60	25	42,0	42 ± 0,15	6,6	16	5	150
WAF-30	30	70	30	49,5	54 ± 0,15	9,0	19	6	300
WAF-40	40	100	40	65,0	68 ± 0,25	11,0	26	8	700
WAF-50	50	100	50	75,0	75 ± 0,25	11,0	36	8	1.200



Order example:
WAF-16: Flange shaft support with inner Ø 16mm



Expert for linear guides: System selection and service life calculation with CAD
Configure linear bearings and calculate their service life – constantly expanded by new sizes and products

Easily calculate the service life of your required linear guide and configure with a few clicks. Select a drylin® system and add the relevant environmental parameters. Select the bearing size, carriage, number and position. Then enter the distance between the rails and the mounting. Define more relevant parameter of the guidance and select a rail length. The results are displayed.



► www.igus-asean.com/drylin-expert



Download the online tool app now



Aluminium shafts in combination with iglidur® J enable high speeds due to the lightweight.



Stainless steel shafts combined with iglidur® X, offer maximum resistance at +120°C. Cleaning in filling machine.



Stainless steel combined with iglidur® J in cut-off grinding machine. Grinding particles and coolants, extreme conditions.



Cost-effective guide for work piece carriage in a machine tool with supported aluminium shaft.

X-ON Electronics

Largest Supplier of Electrical and Electronic Components

Click to view similar products for [Headers & Wire Housings](#) category:

Click to view products by [Igus](#) manufacturer:

Other Similar products are found below :

[0015917161](#) [0022155065](#) [57102-F02-18ULF](#) [58102-G61-06LF](#) [582553-1](#) [01.001.5753.1](#) [0050291907](#) [02.125.8002.8](#) [609-3404](#) [61062-3](#)
[CSU011177004](#) [622-0430](#) [622-3653LF](#) [63453-116](#) [636-1030](#) [636-1427](#) [636-3427](#) [636-4007](#) [641938-9](#) [644827-2](#) [65495-038](#) [65692-001LF](#)
[65781-018](#) [65781-047](#) [65817-010LF](#) [65817-015LF](#) [67095-007LF](#) [67601157](#) [68631-112](#) [68645-018](#) [699319-000](#) [70.362.1628.0](#) [70-4210](#) [70-4226B](#) [70-4853B](#) [71.350.2428.0](#) [733-134](#) [733-162](#) [760-3052](#) [MHR-64-VUAL](#) [80.063.4001.1](#) [800-90-001-10-001000](#) [801-43-002-10-013000](#)
[801-43-006-10-002000](#) [803-43-024-10-001000](#) [803-93-012-10-001000](#) [8-1437020-4](#) [819-22-004-30-001101](#) [820-22-006-30-001101](#)
[821-22-002-10-001101](#)