

3.0 A Step-Down Voltage Regulator

IL2576HV-xx

The IL2576HV series of regulators are monolithic integrated circuits that provide all the active functions for a step-down (buck) switching regulator, capable of driving 3A load with excellent line and load regulation. These devices are available in fixed output voltages of 3.3V, 5.0V, 12V, and adjustable output version. Requiring a minimum number of external components, these regulators are simple to use and include internal frequency compensation and a fixed-frequency oscillator.

The IL2576HV series offers a high-efficiency replacement for popular three-terminal linear regulators. It substantially reduces the size of the heat sink, and in some cases no heat sink is required. A standard series of inductors optimized for use with the IL2576HV are available from several different manufacturers. This feature greatly simplifies the design of switch-mode power supplies.

Other features include a guaranteed $\pm 4\%$ tolerance on output voltage within specified input voltages and output load conditions, and $\pm 10\%$ on the oscillator frequency. The external shutdown function can be controlled by logic level and then come into standby mode. The output switch includes cycle-by-cycle current limiting, as well as thermal shutdown for full protection under fault conditions.

The IL2576HV series are available in a standard 5-lead TO-220 package.

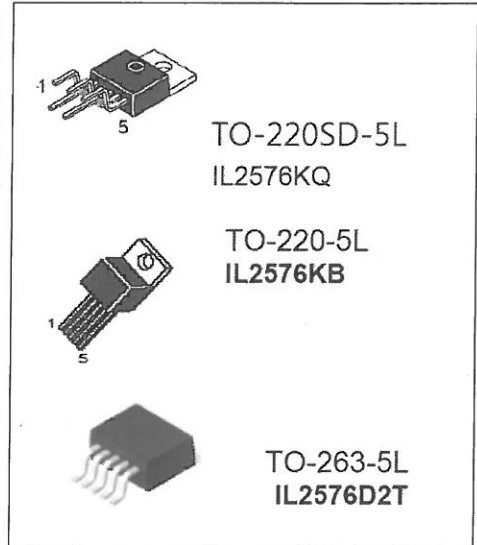

Pin connections

1. Vin
2. Output
3. Ground
4. Feedback
5. ON/OFF

Features

- 3.3 V, 5.0 V, 12 V, and Adjustable Output Versions
- Adjustable version output voltage range, 1.23V to 57V $\pm 4\%$ max over line and load conditions
- Output load current: 3A
- Input voltage range up to 60V
- Requires only 4 external components
- 52 kHz fixed frequency internal oscillator
- TTL shutdown capability, low power standby mode
- High efficiency
- Thermal shutdown and current limit protection
- Built-in switching transistor on chip
- 5-lead TO-220 package

Applications

- Simple High-Efficiency Step-Down (Buck) Regulator
- Efficient Pre-Regulator for Linear Regulators
- On-Card Switching Regulators
- Positive to Negative Converter (Buck-Boost)
- Negative Step-Up Converters
- Power Supply for Battery Chargers

ORDERING INFORMATION

Device	Operating Temperature Range	Package	Packaging
IL2576HV-xxD2T	$T_A = -40^\circ$ to 125° C for all packages	TO-263	Tape & Reel
IL2576HV-xxKB		TO-220	Tube
IL2576HV-xxKQ		TO-220SD	Tube

Figure 1.

Pin Description

Pin number	Symbol	Purpose description
01	V_{IN}	Operating voltage input
02	Output	Switching output
03	GND	Ground
04	FB	Output voltage feedback control
05	ON/OFF	ON/OFF Shutdown

Block diagram

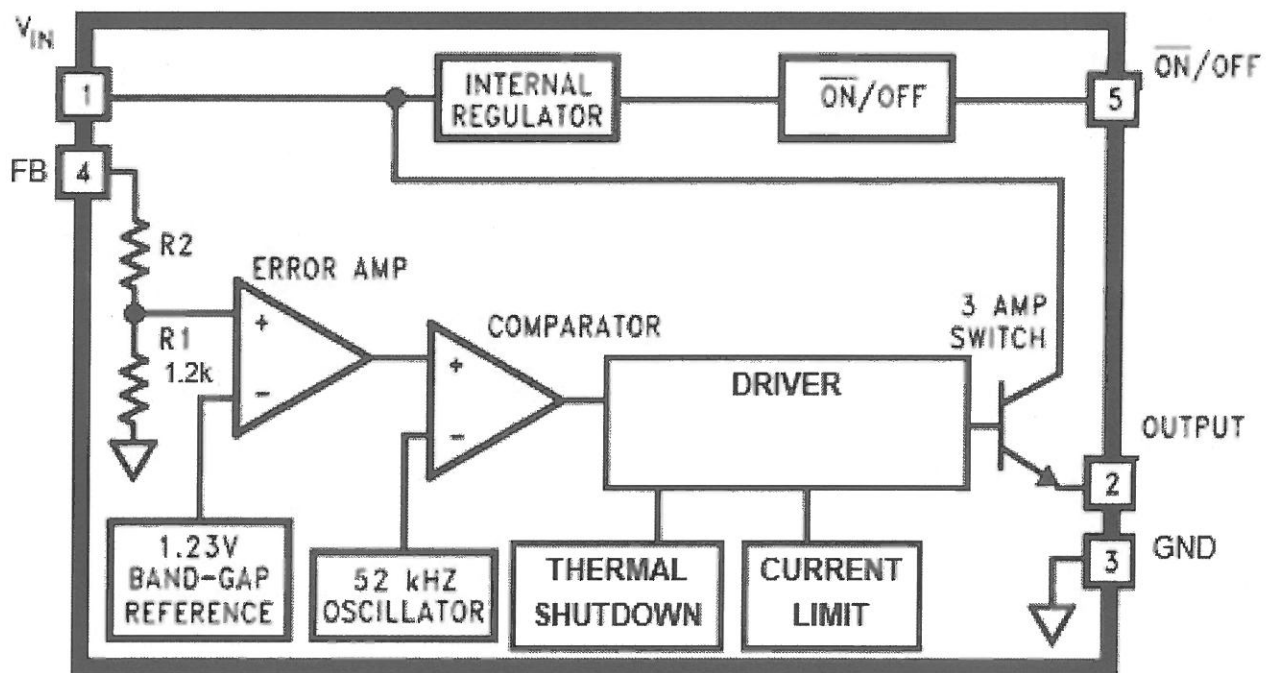

Figure 2.

3.3V $R_2 = 2.02k$
 5.0V, $R_2 = 3.69k$
 12V, $R_2 = 10.56k$
 For adjustable version
 $R_1 = \text{Open}$, $R_2 = 0\Omega$

Typical Electrical Parameters

Parameter, unit	Symbol	Typ. value	Test condition
Efficiency, %	- IL2576HV-ADJ	77	$V_{IN} = 12V, I_{LOAD} = 3A, V_{OUT} = 5V$
	- IL2576HV-3.3	75	$V_{IN} = 12V, I_{LOAD} = 3A$
	- IL2576HV-5.0	77	
	- IL2576HV-12	88	$V_{IN} = 15V, I_{LOAD} = 3A$
Max. Duty Cycle (ON), %	DC_{max}	98	$V_{FB} = 0V$

Typical Application (Fixed Output voltage versions)

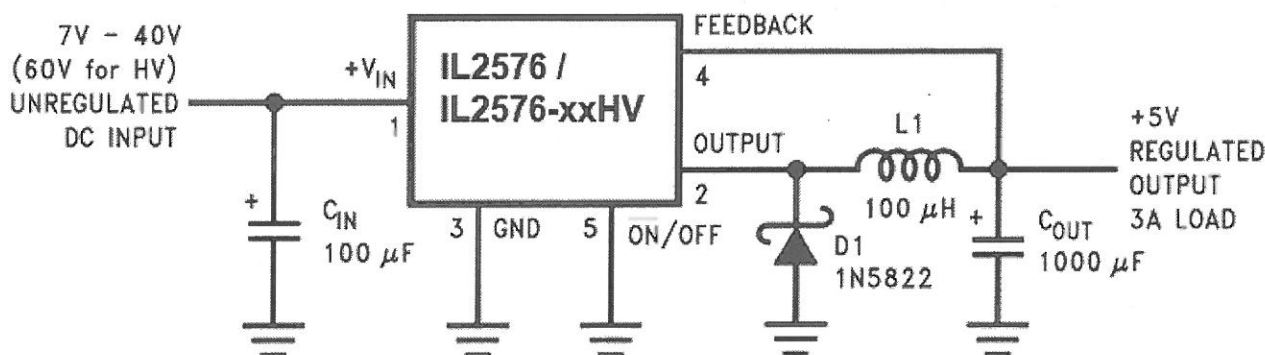

Figure 3.

- C1 – aluminum electrolytic capacitor (100µF, 75V);
- C2 – aluminum electrolytic capacitor (1000µF, 25V);
- L1 – inductor (100µH);
- D1 – Schottky diode

Adjustable Output Voltage Versions

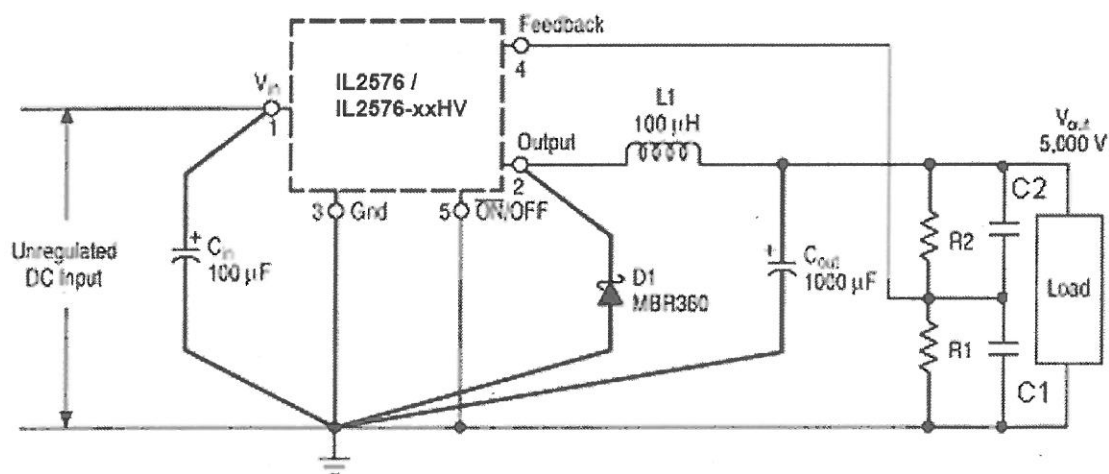

Figure 4.

$$V_{out} = V_{ref} \left(1.0 + \frac{R_2}{R_1} \right), \quad R_2 = R_1 \left(\frac{V_{out}}{V_{ref}} - 1.0 \right)$$

Where $V_{ref} = 1.23V$, R_1 between 1.0 k and 5.0 k
 C1 = 10 nF
 C2 = 1 nF

ABSOLUTE MAXIMUM RATINGS

(Absolute Maximum Ratings indicate limits beyond which damage to the device may occur.)

Rating	Symbol	Value	Unit
Maximum Supply Voltage	V _{in}	63	V
ON/OFF Pin Input Voltage	–	–0.3 V ≤ V ≤ +25	V
Output Voltage to Ground (Steady-State)	–	–1.0	V
Power Dissipation	P _D	Internally Limited	W
TO–220, 5–Lead	R _{θJA}	65	°C/W
Thermal Resistance, Junction–to–Ambient	R _{θJC}	5.0	°C/W
Thermal Resistance, Junction–to–Case	P _D	Internally Limited	W
TO–263, 5–Lead (D2PAK)	R _{θJA}	70	°C/W
Thermal Resistance, Junction–to–Ambient	R _{θJC}	5.0	°C/W
Thermal Resistance, Junction–to–Case	T _{stg}	–65 to +150	°C
Storage Temperature Range	–	2.0	kV
Minimum ESD Rating (Human Body Model: C = 100 pF, R = 1.5 kΩ)	–	260	°C
Lead Temperature (Soldering, 10 seconds)	T _J	150	°C
Maximum Junction Temperature			

* Stresses beyond those listed under “absolute maximum ratings” may cause permanent damage to the device.

These are stress ratings only and functional operation of the device at these or any other conditions beyond those indicated under “recommended operating conditions” is not implied.

Exposure to absolute-maximum-rated conditions for extended periods may affect device reliability.

OPERATING RATINGS

(Operating Ratings indicate conditions for which the device is intended to be functional, but do not guarantee specific performance limits. For guaranteed specifications and test conditions, see the Electrical Characteristics.)

Rating	Symbol	Value	Unit
Operating Junction Temperature Range	T _J	–40 to +125	°C
Supply Voltage	V _{in}	60	V

ELECTRICAL CHARACTERISTICS

(Unless otherwise specified, $V_{in} = 12\text{ V}$ for the 3.3 V, 5.0 V, and Adjustable version, $V_{in} = 25\text{ V}$ for the 12 V version, and $V_{in} = 30\text{ V}$ for the 15 V version. $I_{load} = 500\text{ mA}$, $T_J = 25^\circ\text{C}$, for min/max values T_J is the operating junction temperature range that applies unless otherwise noted)

IC	Parameter, unit	Symbol	Limit		Test condition	$T_A, ^\circ\text{C}$
			min	max		
IL2576HV-ADJ	Feedback bias current, nA	IB	-	100 500	VFB = 1,3V; VIN = 12V	25±10 125* -40
	Oscillator frequency, kHz	fOSC	47 42	58 63	VIN = 12V	
	Saturation voltage, V	VSAT	-	1.8 2,0	VFB = 0V; VIN = 12V; IOUT = 3A no external circuit	
	Current limit, A	ICL	4.2 3.5	6.9 7.5	VFB = 0V; VIN = 12V; 3A ≤ IOUT ≤ 8A no external circuit	
	Output leakage current, mA	IL(0)	-	2	VFB = 12V; VIN = 60V; VOUT = 0V no external circuit	25±10
		IL(-1)	-	30	VFB = 12V; VIN = 60V; VOUT = -1V no external circuit	
	Quiescent current, mA	IQ	-	10	VFB = 12V; VIN = 12V	25±10 125* -40
	Standby quiescent current, uA	ISTBY	-	200	VFB = 0V; VIN = 60V; VON/OFF = 5V	
	ON/OFF pin low level input voltage (switch on), V	VIL	1.0 0.8	-	FB = 0V; IN = 12V	
	ON/OFF pin high level input voltage (switch off), V	VIH	-	2.2 2.4		25±10
	ON/OFF pin high level input current (switch off), uA	IiH	-	30	VFB = 0V; VIN = 12V; VON/OFF = 5V	
	ON/OFF pin low level input current (switch on), uA	IiL	-	10	VFB = 0V; VIN = 12V; VON/OFF = 0V	25±10 125* -40
	Feedback voltage, V	VFB	1.217	1.243	VIN=12V;ILOAD=0.5A; VOUT = 5 V	
			1.193 1.180	1.273 1.286	8V ≤ VIN ≤ 60V; 0.5A ≤ ILOAD ≤ 3A; VOUT = 5 V	

Electrical parameters (continued)

IC	Parameter, unit	Symbol	Limit		Test condition	T _A , °C	
			min	max			
IL2576HV-3.3	Oscillator frequency, kHz	f _{OSC}	$\frac{47}{42}$	$\frac{58}{63}$	V _{IN} = 12V	$\frac{25 \pm 10}{125^*}$ -40	
	Saturation voltage, V	V _{SAT}	-	$\frac{1.8}{2.0}$	V _{FB} = 0V; V _{IN} = 12V; I _{OUT} = 3A no external circuit		
	Current limit, A	I _{CL}	$\frac{4.2}{3.5}$	$\frac{6.9}{7.5}$	V _{FB} = 0V; V _{IN} = 12V; 3A ≤ I _{OUT} ≤ 8A no external circuit		
	Output leakage current, mA	I _{L(0)}	-	2	V _{FB} = 12V; V _{IN} = 60V; V _{OUT} = 0V no external circuit	25 ± 10	
		I _{L(-1)}	-	30	V _{FB} = 12V; V _{IN} = 60V; V _{OUT} = -1V no external circuit		
	Quiescent current, mA	I _Q	-	10	V _{FB} = 12V; V _{IN} = 12V		
	Standby quiescent current, uA	I _{STBY}	-	200	V _{FB} = 0V; V _{IN} = 60V; V _{ON/OFF} = 5V		
	ON/OFF pin low level input voltage (switch on), V	V _{IL}	$\frac{1.0}{0.8}$	-	V _{FB} = 0V; V _{IN} = 12V	$\frac{25 \pm 10}{125^*}$ -40	
	ON/OFF pin high level input voltage (switch off), V	V _{IH}	-	$\frac{2.2}{2.4}$			
	ON/OFF pin high level input current (switch off), uA	I _{IH}	-	30	V _{FB} = 0V; V _{IN} = 12V; V _{ON/OFF} = 5V	25 ± 10	
	ON/OFF pin low level input current (switch on), uA	I _{IL}	-	10	V _{FB} = 0V; V _{IN} = 12V; V _{ON/OFF} = 0V		
	Output voltage, V	V _{OUT}		3.234	3.366	V _{IN} = 12V; I _{LOAD} = 0.5A	
				$\frac{3.168}{3.135}$	$\frac{3.450}{3.482}$	6V ≤ V _{IN} ≤ 60V; 0.5A ≤ I _{LOAD} ≤ 3A	$\frac{25 \pm 10}{125^*}$ -40

Electrical parameters (continued)

IC	Parameter, unit	Symbol	Limit		Test condition	T _A , °C
			min	max		
IL2576HV-5.0	Oscillator frequency, kHz	f _{OSC}	$\frac{47}{42}$	$\frac{58}{63}$	V _{IN} = 12V	$\frac{25 \pm 10}{125^*}$ -40
	Saturation voltage, V	V _{SAT}	-	$\frac{1.8}{2.0}$	V _{FB} = 0V; V _{IN} = 12V; I _{OUT} = 3A no external circuit	
	Current limit, A	I _{CL}	$\frac{4.2}{3.5}$	$\frac{6.9}{7.5}$	V _{FB} = 0V; V _{IN} = 12V; 3A ≤ I _{OUT} ≤ 8A no external circuit	
	Output leakage current, mA	I _{L(0)}	-	2	V _{FB} = 12V; V _{IN} = 60V; V _{OUT} = 0V no external circuit	25±10
		I _{L(-1)}	-	30	V _{FB} = 12V; V _{IN} = 60V; V _{OUT} = -1V no external circuit	
	Quiescent current, mA	I _Q	-	10	V _{FB} = 12V; V _{IN} = 12V	
	Standby quiescent current, μA	I _{STBY}	-	200	V _{FB} = 0V; V _{IN} = 60V; V _{ON/OFF} = 5V	
	ON/OFF pin low level input voltage (switch on), V	V _{IL}	$\frac{1.0}{0.8}$	-	V _{FB} = 0V; V _{IN} = 12V	$\frac{25 \pm 10}{125^*}$ -40
	ON/OFF pin high level input voltage (switch off), V	V _{IH}	-	$\frac{2.2}{2.4}$		
	ON/OFF pin high level input current (switch off), μA	I _{IH}	-	30	V _{FB} = 0V; V _{IN} = 12V; V _{ON/OFF} = 5V	25±10
	ON/OFF pin low level input current (switch on), μA	I _{IL}	-	10	V _{FB} = 0V; V _{IN} = 12V; V _{ON/OFF} = 0V	
	Output voltage, V	V _{OUT}	4.90	5.10	V _{IN} = 12V; I _{LOAD} = 0.5A	
			$\frac{4.800}{4.750}$	$\frac{5.225}{5.275}$	8V ≤ V _{IN} ≤ 60V; 0.5A ≤ I _{LOAD} ≤ 3A	$\frac{25 \pm 10}{125^*}$ -40

Electrical parameters (continued)

IC	Parameter, unit	Symbol	Limit		Test condition	T _A , °C
			min	max		
IL2576HV-12	Oscillator frequency, kHz	f _{OSC}	$\frac{47}{42}$	$\frac{58}{63}$	V _{IN} = 25V	$\frac{25 \pm 10}{125^*}$ -40
	Saturation voltage, V	V _{SAT}	-	$\frac{1.8}{2.0}$	V _{FB} = 0V; V _{IN} = 25V; I _{OUT} = 3A no external circuit	
	Current limit, A	I _{CL}	$\frac{4.2}{3.5}$	$\frac{6.9}{7.5}$	V _{FB} = 0V; V _{IN} = 25V; 3A ≤ I _{OUT} ≤ 8A no external circuit	
	Output leakage current, mA	I _{L(0)}	-	2	V _{FB} = 25V; V _{IN} = 60V; V _{OUT} = 0V no external circuit	25±10
		I _{L(-1)}	-	30	V _{FB} = 25V; V _{IN} = 60V; V _{OUT} = -1V no external circuit	
	Quiescent current, mA	I _Q	-	10	V _{FB} = 25V; V _{IN} = 25V	
	Standby quiescent current, uA	I _{STBY}	-	200	V _{FB} = 0V; V _{IN} = 60V; V _{ON/OFF} = 5V	
	ON/OFF pin low level input voltage (switch on), V	V _{IL}	$\frac{1.0}{0.8}$	-	V _{FB} = 0V; V _{IN} = 25V	$\frac{25 \pm 10}{125^*}$ -40
	ON/OFF pin high level input voltage (switch off), V	V _{IH}	-	$\frac{2.2}{2.4}$		
	ON/OFF pin high level input current (switch off), uA	I _{IH}	-	30	V _{FB} = 0V; V _{IN} = 25V; V _{ON/OFF} = 5V	25±10
	ON/OFF pin low level input current (switch on), uA	I _{IL}	-	10	V _{FB} = 0V; V _{IN} = 25V; V _{ON/OFF} = 0V	
	Output voltage, V	V _{OUT}	11.76	12.24	V _{IN} = 25V; I _{LOAD} = 0.5A	
			$\frac{11.52}{11.40}$	$\frac{12.54}{12.66}$	15V ≤ V _{IN} ≤ 60V; 0.5A ≤ I _{LOAD} ≤ 3A	$\frac{25 \pm 10}{125^*}$ -40

* Junction temperature. Junction temperature is equal to ambient because of measurements of electric parameters are executed in pulse mode.

Application Information

INVERTING REGULATOR

Figure 5 shows a IL2576-12 in a buck-boost configuration to generate a negative 12V output from a positive input voltage. This circuit bootstraps the regulator's ground pin to the negative output voltage, then by grounding the feedback pin, the regulator senses the inverted output voltage and regulates it to -12V.

For an input voltage of 12V or more, the maximum available output current in this configuration is approximately 700 mA. At lighter loads, the minimum input voltage required drops to approximately 4.7V.

The switch currents in this buck-boost configuration are higher than in the standard buck-mode design, thus lowering the available output current. Also, the start-up input current of the buck-boost converter is higher than the standard buck-mode regulator, and this may overload an input power source with a current limit less than 5A. Using a delayed turn-on or an undervoltage lockout circuit (described in the next section) would allow the input voltage to rise to a high enough level before the switcher would be allowed to turn on.

Because of the structural differences between the buck and the buck-boost regulator topologies, the buck regulator design procedure section can not be used to select the inductor or the output capacitor. The recommended range of inductor values for the buck-boost design is between 68 μ H and 220 μ H, and the output capacitor values must be larger than what is normally required for buck designs. Low input voltages or high output currents require a large value output capacitor (in the thousands of micro Farads).

The peak inductor current, which is the same as the peak switch current, can be calculated from the following formula:

$$I_p \approx \frac{I_{LOAD} (V_{IN} + |V_O|) + \frac{V_{IN} |V_O|}{V_{IN} + |V_O|} \times \frac{1}{2L_1 f_{osc}}}{V_{IN}}$$

Where $f_{osc} = 52$ kHz. Under normal continuous inductor current operating conditions, the minimum V_{IN} represents the worst case. Select an inductor that is rated for the peak current anticipated.

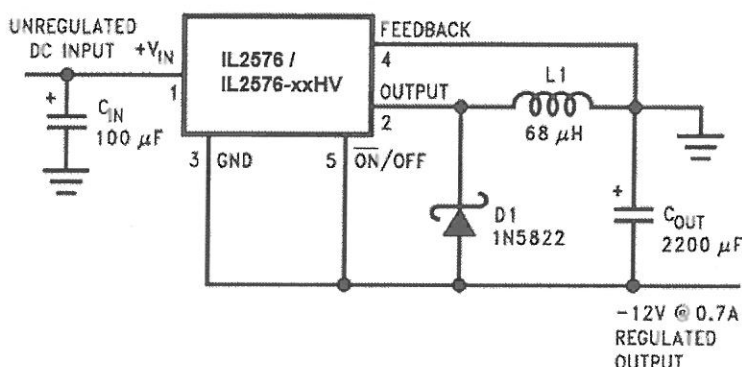
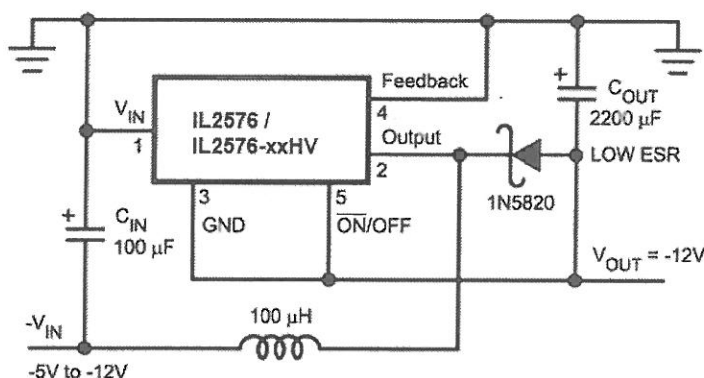

FIGURE 5. Inverting Buck-Boost Develops -12V

Also, the maximum voltage appearing across the regulator is the absolute sum of the input and output voltage. For a -12V output, the maximum input voltage for the IL2576 is +28V.

NEGATIVE BOOST REGULATOR

Another variation on the buck-boost topology is the negative boost configuration. The circuit in Figure 6 accepts an input voltage ranging from -5V to -12V and provides a regulated -12V output. Input voltages greater than -12V will cause the output to rise above -12V, but will not damage the regulator.



Typical Load Current
 400 mA for $V_{IN} = -5.2V$
 750 mA for $V_{IN} = -7V$
 Note: Heat sink may be required.

FIGURE 6. Negative Boost

Because of the boosting function of this type of regulator, the switch current is relatively high, especially at low input voltages.

Output load current limitations are a result of the maximum current rating of the switch. Also, boost regulators can not provide current limiting load protection in the event of a shorted load, so some other means (such as a fuse) may be necessary.

UNDERVOLTAGE LOCKOUT

In some applications it is desirable to keep the regulator off until the input voltage reaches a certain threshold. An undervoltage lockout circuit which accomplishes this task is shown in Figure 7 while Figure 8 shows the same circuit applied to a buck-boost configuration. These circuits keep the regulator off until the input voltage reaches a predetermined level.

$$V_{TH} = V_{Z1} + 2V_{BE}(Q1)$$

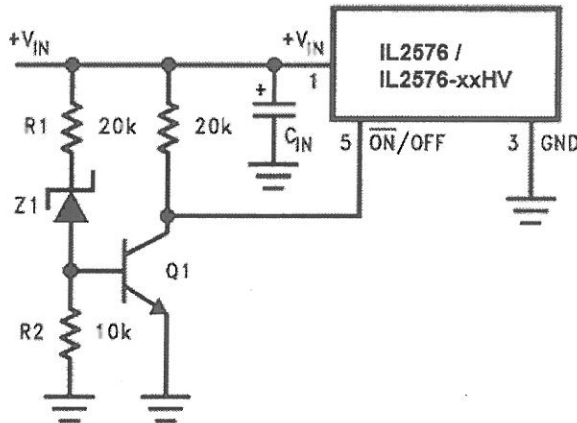

Note: Complete circuit not shown.

FIGURE 7. Undervoltage Lockout for Buck Circuit

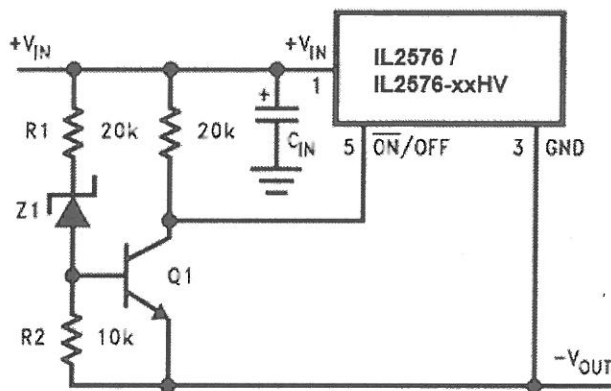

Note: Complete circuit not shown (see Figure 10).

FIGURE 8. Undervoltage Lockout for Buck-Boost Circuit

DELAYED STARTUP

The ON /OFF pin can be used to provide a delayed startup feature as shown in Figure 9. With an input voltage of 20V and for the part values shown, the circuit provides approximately 10 ms of delay time before the circuit begins switching.

Increasing the RC time constant can provide longer delay times. But excessively large RC time constants can cause problems with input voltages that are high in 60 Hz or 120 Hz ripple, by coupling the ripple into the ON /OFF pin.

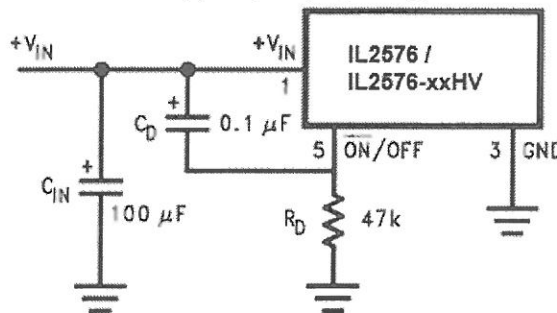

Note: Complete circuit not shown.

FIGURE 9. Delayed Startup

ADJUSTABLE OUTPUT, LOW-RIPPLE POWER SUPPLY

A 3A power supply that features an adjustable output voltage is shown in Figure 10. An additional L-C filter that reduces the output ripple by a factor of 10 or more is included in this circuit.

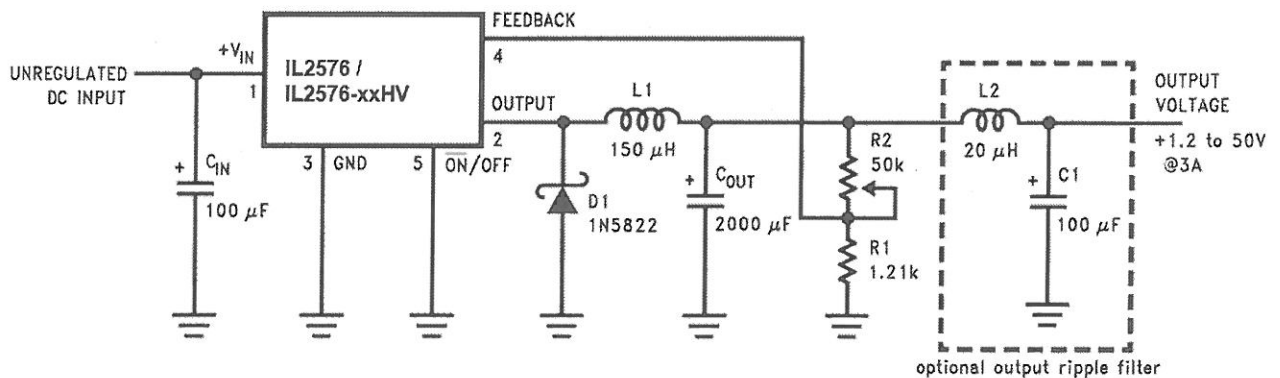

FIGURE 10. Adjustable 3A Power Supply with Low Output Ripple

Definition of Terms

BUCK REGULATOR

A switching regulator topology in which a higher voltage is converted to a lower voltage. Also known as a step-down switching regulator.

BUCK-BOOST REGULATOR

A switching regulator topology in which a positive voltage is converted to a negative voltage without a transformer.

DUTY CYCLE (D)

Ratio of the output switch's on-time to the oscillator period.

$$\text{for buck regulator } D = \frac{t_{ON}}{T} = \frac{V_{OUT}}{V_{IN}}$$

$$\text{for buck-boost regulator } D = \frac{t_{ON}}{T} = \frac{|V_O|}{|V_O| + V_{IN}}$$

CATCH DIODE OR CURRENT STEERING DIODE

The diode which provides a return path for the load current when the IL2576 switch is OFF.

EFFICIENCY (η)

The proportion of input power actually delivered to the load.

$$\eta = \frac{P_{OUT}}{P_{IN}} = \frac{P_{OUT}}{P_{OUT} + P_{LOSS}}$$

TO-220-5L

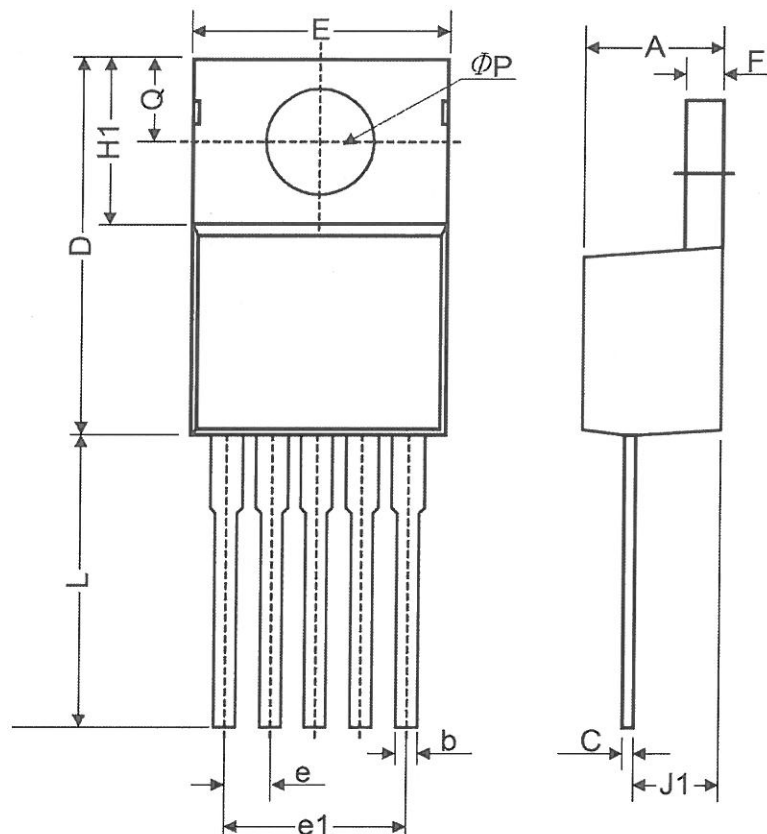

Symbol	Dimensions In Millimeters			Dimensions In Inches		
	Min.	Nom.	Max.	Min.	Nom.	Max.
A	4.07	4.45	4.82	0.160	0.175	0.190
b	0.76	0.89	1.02	0.030	0.035	0.040
C	0.36	0.50	0.64	0.014	0.020	0.025
D	14.22	14.86	15.50	0.560	0.585	0.610
E	9.78	10.16	10.54	0.385	0.400	0.415
e	1.57	1.71	1.85	0.062	0.067	0.073
e1	6.68	6.81	6.93	0.263	0.268	0.273
F	1.14	1.27	1.40	0.045	0.050	0.055
H1	5.46	6.16	6.86	0.215	0.243	0.270
J1	2.29	2.74	3.18	0.090	0.108	0.125
L	13.21	13.97	14.73	0.520	0.550	0.580
Øp	3.68	3.81	3.94	0.145	0.150	0.155
Q	2.54	2.73	2.92	0.100	0.107	0.115

TO-263-5L

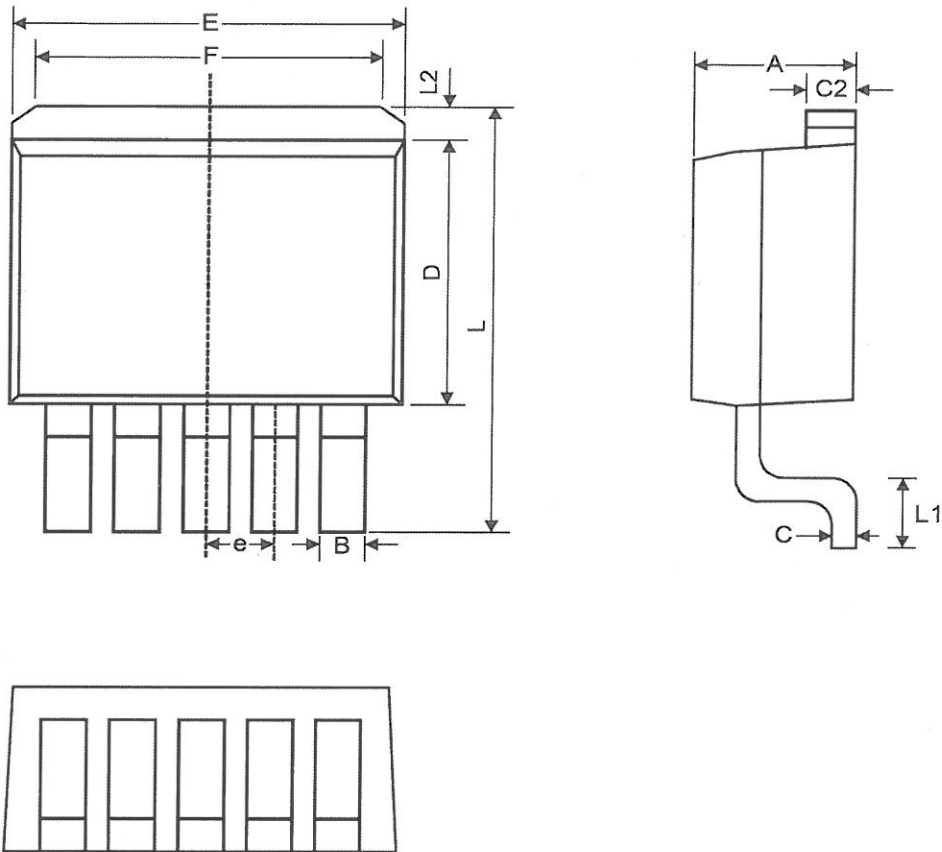

Symbol	Dimensions In Millimeters			Dimensions In Inches		
	Min.	Nom.	Max.	Min.	Nom.	Max.
A	4.07	4.46	4.85	0.160	0.176	0.191
B	0.66	0.84	1.02	0.026	0.033	0.040
C	0.36	0.50	0.64	0.014	0.020	0.025
C2	1.14	1.27	1.40	0.045	0.050	0.055
D	8.65	9.15	9.65	0.341	0.360	0.380
E	9.78	10.16	10.54	0.385	0.400	0.415
e	1.57	1.71	1.85	0.062	0.068	0.073
F	6.60	6.86	7.11	0.260	0.270	0.280
L	14.61	15.24	15.88	0.575	0.600	0.625
L1	2.29	2.54	2.79	0.090	0.100	0.110
L2	-	-	2.92	-	-	0.115

TO-220-5L (Bent Staggered)

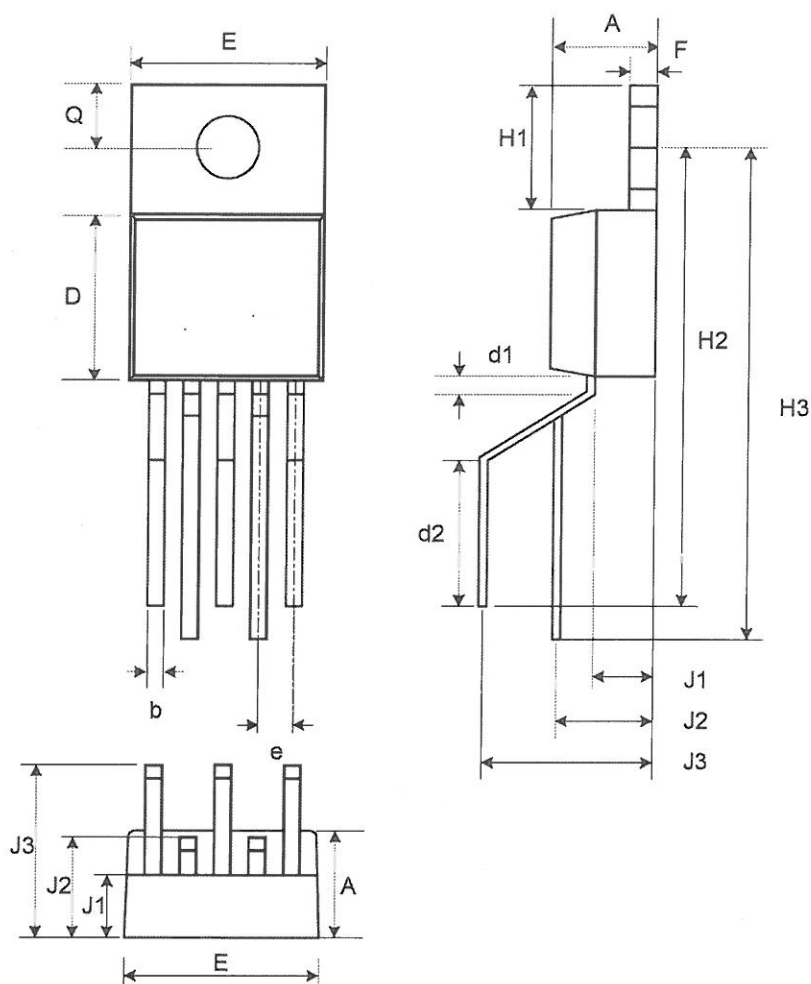

Symbol	Dimensions In Millimeters			Dimensions In Inches		
	Min.	Nom.	Max.	Min.	Nom.	Max.
A	4.4	4.6	4.7	0.175	0.180	0.185
b	0.7	0.8	0.9	0.027	0.032	0.037
D	8.4	8.7	8.9	0.330	0.340	0.350
d1	1.0			0.039		
d2	6.3			0.248		
E	9.91	10.16	10.41	0.390	0.400	0.410
e	1.6	1.7	1.8	0.062	0.067	0.072
F	1.2	1.25	1.3	0.048	0.050	0.052
H1	6.4			0.250		
H2	20.8	21.6	22.4	0.820	0.850	0.880
H3	23.9	24.7	25.5	0.942	0.972	1.002
J1	2.7			0.105		
J2	3.7	4.5	5.3	0.147	0.177	0.207
J3	8.4			0.331		
Q	2.5	2.8	3.0	0.100	0.110	0.120

Document Revision History

Rev	Date	Initiator	Description of Change
00	2019. 05.. 15	HG Ryu	Initial Release

X-ON Electronics

Largest Supplier of Electrical and Electronic Components

Click to view similar products for [Isolated DC/DC Converters](#) category:

Click to view products by [IKSEMICON](#) manufacturer:

Other Similar products are found below :

[ESM6D044440C05AAQ](#) [FMD15.24G](#) [PSL486-7LR](#) [PSR152.5-7IR](#) [Q48T30020-NBB0](#) [AVO240-48S12B-6L](#) [AVO250-48S28B-6L](#) [NAN-0505](#) [HW-L16D](#) [JAHW100Y1](#) [217-1617-001](#) [22827](#) [SPB05C-12](#) [SQ24S15033-PS0S](#) [18952](#) [19-130041](#) [CE-1003](#) [CE-1004](#) [GQ2541-7R](#) [PSE1000DCDC-12V](#) [RDS180245](#) [MAU228](#) [419-2065-201](#) [449-2075-101](#) [TME 0303S](#) [TME 0505S](#) [TME 1205S](#) [TME 1212S](#) [TME 2405S](#) [TME 2412S](#) [J80-0041NL](#) [V300C24C150BG](#) [419-2062-200](#) [419-2063-401](#) [419-2067-101](#) [419-2067-501](#) [419-2068-001](#) [DCG40-5G](#) [DFC15U48D15](#) [449-2067-000](#) [XGS-0512](#) [XGS-1205](#) [XGS-1212](#) [XGS-2412](#) [XGS-2415](#) [XKS-1215](#) [033456](#) [NCT1000N040R050B](#) [SPB05B-15](#) [SPB05C-15](#)