

CAN TRANSCEIVER

ILA82C251

The ILA82C251 is the interface between the CAN protocol controller and the physical bus. The device provides differential transmit capability to the bus and differential receive capability to the CAN controller. The IC is intended for automotive electronic applications

ORDERING INFORMATION

Device	Operating Temperature Range	Package	Shipping
ILA82C251D	T _j = -40° to 125° C	SOP-8	Tube
ILA82C251DT	T _j = -40° to 125° C	SOP-8	Tape & Reel

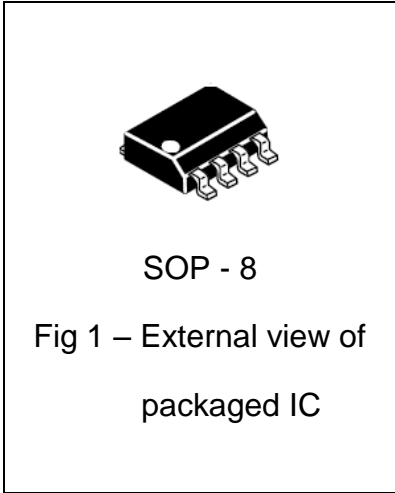

FEATURES

- Fully compatible with the “ISO 11898-24 V” standard
- Thermally protected
- Short-circuit proof
- Three mode operation
- An unpowered node does not disturb the bus lines
- At least 110 nodes can be connected
- High speed of data transfer (up to 1 Mbit/s)
- High immunity against electromagnetic interference.

Permissible value of electrostatic potential is 2000V.
The IC is realized in SOP - 8 package (MS-012AA)

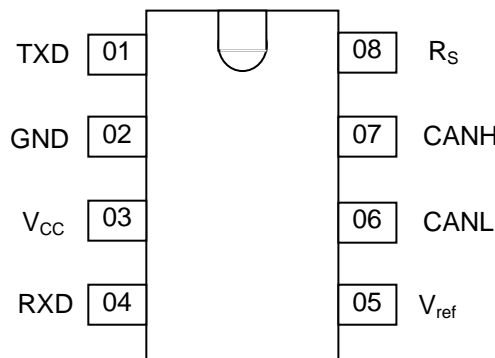
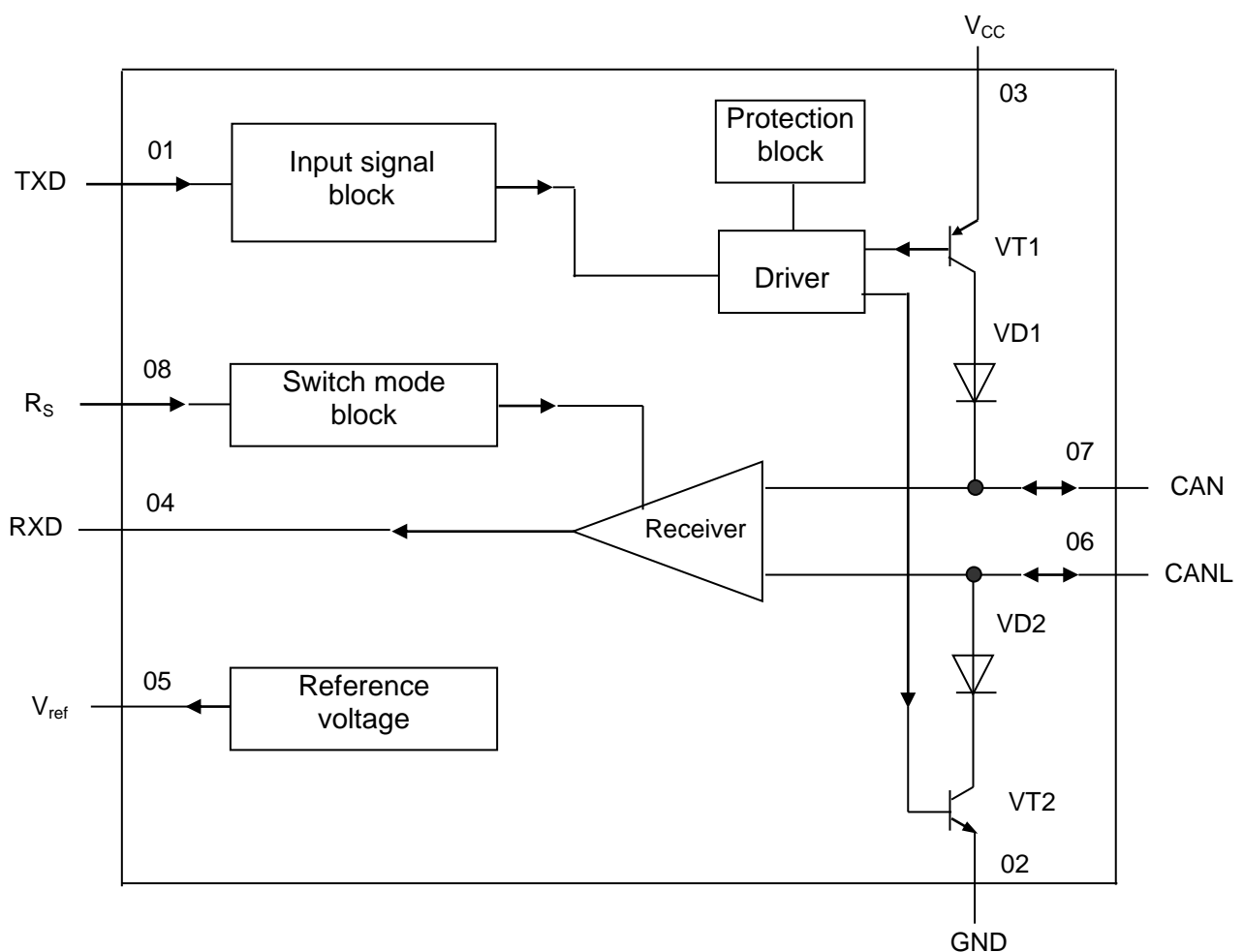

Fig. 2 – Pin layout

Table 1 – Pin description

Pin number	Pad number	Symbol	Description
01	01	TXD	Transmit data input (transmitter)
02	02	GND	Ground
03	03	V _{CC}	Supply voltage
04	05	RXD	Receive data output (receiver)
05	06	V _{ref}	Reference voltage output
06	07	CANL	LOW-level CAN voltage input/output
07	08	CANH	HIGH-level CAN voltage input/output
08	09	R _s	Mode set input
-	04	-	Not bonded



VD1, VD2 – diodes;
VT1, VT2 - transistors

Fig. 3 – Block diagram

Table 2 – Absolute maximum ratings

Symbol	Parameter	Target		Unit
		Min	Max	
V_{CC}	Supply voltage	-0,3	7,0	V
V_n	01, 04, 05, 08 pin voltage	-0,3	$V_{CC} + 0,3$	V
V_{tr}	06, 07 pin transient voltage	-200	200	V
T_{stg}	Storage temperature	-60	150	°C
T_j	Junction temperature	-	150	°C

* Stresses beyond those listed under “absolute maximum ratings” may cause permanent damage to the device.

These are stress ratings only and functional operation of the device at these or any other conditions beyond those indicated under “recommended operating conditions” is not implied.

Exposure to absolute-maximum-rated conditions for extended periods may affect device reliability.

Table 3 – Recommended operating condition

Symbol	Parameter	Target		Unit
		Min	Max	
V_{CC}	Supply voltage	4,5	5,5	V
V_{CAN}	Input/output high and low level voltage of CAN - signal	-36	36	V

Table 4 – Electric parameters at $-40^{\circ} \leq T_{amb} \leq +125^{\circ}C$

Symbol	Parameter	Measurement mode	Target		Unit
			Min	Max	
Supply					
I ₃	Supply current	Dominant; V ₁ = 1,0 V, V _{CC} < 5,1 V	-	78	mA
		Dominant; V ₁ = 1,0 V, V _{CC} < 5,25 V	-	80	
		Dominant; V ₁ = 1,0 V, V _{CC} < 5,5 V	-	85	
		Recessive; V ₁ = 4,0 V, R ₈ = 47 kΩ	-	10	
		Standby mode ¹⁾	-	0,315	
		Standby mode ²⁾	-	0,275	
Transmitter					
V _{IH}	High-level input voltage	Output recessive	0,7 V _{CC}	V _{CC} +0,3	V
V _{IL}	Low-level input voltage	Output dominant	-0,3	0,3 V _{CC}	V
I _{IH}	High-level input current	4,5 V < V _{CC} < 5,5 V V ₁ = 4,0 V	-200	30	μA
I _{IL}	Low-level input current	4,5 V < V _{CC} < 5,5 V V ₁ = 1,0 V	-200	-100	μA
V _{6,7}	Recessive bus voltage	4,5 V < V _{CC} < 5,5 V V ₁ = 4,0 V, no load	2,0	3,0	V
I _{LO}	Off-state output leakage current	4,5 V < V _{CC} < 5,5 V -2,0 V < (V ₆ , V ₇) < 7,0 V	-2,0	2,0	mA
		4,5 V < V _{CC} < 5,5 V -5,0 V < (V ₆ , V ₇) < 36 V	-10	10	
V ₇	CANH output voltage	4,75 V < V _{CC} < 5,5 V V ₁ = 1,0 V	3,0	4,5	V
		V ₁ = 1,0 V 4,5 V < V _{CC} < 4,75 V	2,75	4,5	
V ₆	CANL output voltage	4,5 V < V _{CC} < 5,5 V V ₁ = 1,0 V	0,5	2,0	V

Table 4 continued

Symbol	Parameter	Measurement mode	Target		Unit
			Min	Max	
$\Delta V_{6,7}$	difference between output voltage at pins 6 and 7	$4,5\text{ V} < V_{CC} < 5,5\text{ V}$ $V_1 = 1,0\text{ V}$	1,5	3,0	V
		$V_1 = 1,0\text{ V}, R_L = 45\ \Omega$	1,5	-	
		$V_1 = 4,0\text{ V}, \text{no load}$	-0,5	0,05	
I_{SC7}	CANH short-circuit current	$4,5\text{ V} < V_{CC} < 5,5\text{ V}$ $V_7 = -5,0\text{ V}$	-	-200	mA
I_{SC6}	CANL signal short-circuit current	$4,5\text{ V} < V_{CC} < 5,5\text{ V}$ $V_6 = 36\text{ V}^{3)}$	-	200	mA
Receiver (pins 06, 07 are externally controlled, $V_4 = 4,0\text{ V}$, $-2,0\text{ V} < (V_6, V_7) < 7,0\text{ V}$, unless otherwise specified)					
$V_{DIFF(R)}$	Differential input voltage (recessive mode)	⁴⁾	-1,0	0,5	V
		$4,5\text{ V} < V_{CC} < 5,5\text{ V}$ $-7,0\text{ V} < (V_6, V_7) < 12\text{ V}$ ⁴⁾	-1,0	0,4	
$V_{DIFF(D)}$	Differential input voltage (dominant mode)	-	0,9	5,0	V
		$4,5\text{ V} < V_{CC} < 5,5\text{ V}$ $-7,0\text{ V} < (V_6, V_7) < 12\text{ V}$ ⁵⁾	1,0	5,0	
		⁵⁾	0,97	5,0	
		$4,5\text{ V} < V_{CC} < 5,1\text{ V}$ ⁵⁾	0,91	5,0	
V_{OH}	High-level output voltage (pin 4)	$4,5\text{ V} < V_{CC} < 5,5\text{ V}$ $I_4 = -100\ \mu\text{A}$	$0,8 V_{CC}$	V_{CC}	V
V_{OL}	Low-level output voltage (pin 4)	$4,5\text{ V} < V_{CC} < 5,5\text{ V}$ $I_4 = 1,0\text{ mA}$	0	$0,2 V_{CC}$	V
		$4,5\text{ V} < V_{CC} < 5,5\text{ V}$ $I_4 = 10\text{ mA}$	0	1,5	
R_I	CANL and CANH input resistance I	$4,5\text{ V} < V_{CC} < 5,5\text{ V}$	5,0	25	k Ω
R_{DIFF}	Differential input resistance	$4,5\text{ V} < V_{CC} < 5,5\text{ V}$	20	100	k Ω
Reference voltage					
V_{REF}	Reference voltage	$4,5\text{ V} < V_{CC} < 5,5\text{ V}$ $V_8 = 1,0\text{ V}, I_5 < 50\ \mu\text{A}$	$0,45 V_{CC}$	$0,55 V_{CC}$	V
		$4,5\text{ V} < V_{CC} < 5,5\text{ V}$ $V_8 = 4,0\text{ V}, I_5 < 5,0\ \mu\text{A}$	$0,4 V_{CC}$	$0,6 V_{CC}$	

Table 4 continued

Symbol	Parameter	Measurement mode	Target		Unit
			Min	Max	
Timing parameters ($R_L = 60 \Omega$, $C_L = 100 \text{ pF}$, unless otherwise specified)					
t_{bit}	One bit transmitting minimum time	$4,5 \text{ V} < V_{\text{CC}} < 5,5 \text{ V}$ $R_8 = 0 \Omega$	-	1,0	μs
t_{onTXD}	Input data transfer to active bus delay	$4,5 \text{ V} < V_{\text{CC}} < 5,5 \text{ V}$ $R_8 = 0 \Omega$	-	50	ns
t_{offTXD}	Input data transfer to inactive bus delay	$4,5 \text{ V} < V_{\text{CC}} < 5,5 \text{ V}$ $R_8 = 0 \Omega$	-	80	ns
t_{onRXD}	Input data transfer to active receiver delay	$4,5 \text{ V} < V_{\text{CC}} < 5,5 \text{ V}$ $R_8 = 0 \Omega$	-	120	ns
		$4,5 \text{ V} < V_{\text{CC}} < 5,5 \text{ V}$ $R_8 = 47 \text{ k}\Omega$	-	550	
t_{offRXD}	Input data transfer to inactive receiver delay	$4,5 \text{ V} < V_{\text{CC}} < 5,5 \text{ V}$ $R_8 = 0 \Omega$	-	190	ns
		$4,5 \text{ V} < V_{\text{CC}} < 5,5 \text{ V}$ $R_8 = 47 \text{ k}\Omega$	-	400	
t_{WAKE}	Wake-up time from standby mode (via 08 pin)	$4,5 \text{ V} < V_{\text{CC}} < 5,5 \text{ V}$	-	20	μs
t_{dRXDL}	Bus input data transfer delay to low on output of received data	$4,5 \text{ V} < V_{\text{CC}} < 5,5 \text{ V}$ $V_8 = 4,0 \text{ V}$	-	3,0	μs
Standby mode and low RFI mode					
V_{stb}	Input voltage for standby mode	$4,5 \text{ V} < V_{\text{CC}} < 5,5 \text{ V}$	$0,75 V_{\text{CC}}$	-	V
I_{slope}	Input current for low RFI mode	$4,5 \text{ V} < V_{\text{CC}} < 5,5 \text{ V}$	- 200	- 10	μA
V_{slope}	Input voltage for low RFI mode	$4,5 \text{ V} < V_{\text{CC}} < 5,5 \text{ V}$	$0,4 V_{\text{CC}}$	$0,6 V_{\text{CC}}$	V
<p>1) $I_1 = I_4 = I_5 = 0 \text{ mA}$, $V_8 = V_{\text{CC}}$</p> <p>2) $I_1 = I_4 = I_5 = 0 \text{ mA}$, $V_8 = V_{\text{CC}}$, $T_{\text{amb}} < 90 \text{ }^\circ\text{C}$.</p> <p>3) TXD is LOW, Short-circuit protection provided for slew rate up to 5V/us for Voltage above +20V</p> <p>4) For the receiver in all modes.</p> <p>5) Standby mode</p>					

Table 5 Typical values of electric parameters

Symbol	Parameter	Measurement mode	Typical value	Unit
$V_{\text{diff(hys)}}$	Differential hysteresis voltage	V_{CC} from 4,5 to 5,5 V	150	mV
$ \text{SR} $	CANH, CANL slew rate	V_{CC} from 4,5 to 5,5 V; $R_8 = 47 \text{ k}\Omega$	7,0	V/ μs
I_{SC7}	High level CAN short circuit current	V_{CC} from 4,5 to 5,5 V; $V_7 = -36 \text{ V}$	-100	mA

FUNCTIONAL DESCRIPTION

The INA82C251 provides differential transmit capability to the bus and differential receive capability to the CAN controller. Data transfer rate is up to 1 Mbit/s.

Output stage has good load capacity. It guarantees 2V peak-to-peak output voltage for 60 Ω load. ILA82C251D has thermal and short circuit protection, high immunity to EMI and is fully compatible with the "ISO 11898-24 V" standard.

The IC provides three operation modes: high-speed, reduced RFI mode, standby mode. The design of ILA82C251D permits possibility of adjustment of rise and fall slope of output stages (transistors).

Pin R_S is used to select one of three modes of operation: high-speed, reduced RFI or standby. High level applied to this pin switches the IC to standby mode, low level – to high-speed mode. The high-speed mode is selected by connecting pin R_S to ground. To reduce RFI, connect pin R_S by resistor R_{ext} to ground. The rise and fall slope of output stages (transistors) can be regulated with R_{ext} resistance.

To select high-speed dominant mode a low level voltage ($\sim 1 \text{ V}$) is applied to TXD pin and R_S is connected to ground, CANH and CANL pins are connected by 60 Ω resistor. Guaranteed peak-to-peak output voltage (high and low level) will be 1,5 V for all operating supply voltage range

To select recessive mode a high level voltage ($\sim 4 \text{ V}$) is applied to TXD pin and R_S is connected to ground. In recessive mode bus output voltage $V_{6,7}$ is about ($\sim 2.5 \text{ V}$).

High level ($\sim 4\text{V}$) applied to pin R_S switches IC to standby mode (with low power consumption); in this mode consumption current doesn't exceed 270 μA . In this mode transmitter is turn off and consumption current of receiver and all circuit is significantly decreased.

Reference voltage value V_{REF} per 05 output is half of supply voltage.

Table 6 - Truth table of the transceiver

Supply voltage range, V_{CC} , V	TXD pin	CANH pin	CANL pin	Bus state	RXD output
4,5 ÷ 5,5	L	H	L	Dominant	L
4,5 ÷ 5,5	H	Floating	Floating	Recessive	H *
4,5 ÷ 5,5	X	Floating, if $V_{RS} > 0,75 V_{CC}$	Floating, if $V_{RS} > 0,75 V_{CC}$	Floating	H *
0 ÷ 5,5	Floating	Floating	Floating	Floating	X

Notes

1 H – high level voltage; L – low level voltage; X – don't care (H or L).

2 Floating state – half of sum of output levels on pins 06 and 07 ($V_{O(CANL)} + V_{O(CANH)} / 2$).

* If another bus node is transmitting a dominant bit, then RXD shall be low

Table 7 – Transceiver mode table

R_S pin state	Mode	R_S pin resulting voltage or current
$V_{RS} > 0,75 V_{CC}$	Standby	- $I_{RS} < 10 \mu A$
$10 \mu A < -I_{RS} < 200 \mu A$	Slope control (Reduced RFI)	$0,4 V_{CC} < V_{RS} < 0,6 V_{CC}$
$V_{RS} < 0,3 V_{CC}$	High – speed	- $I_{RS} < 500 \mu A$

Table 8 - Truth table of the receiver

Input differential voltage V_{DIFF}^* , B	RXD pin
$V_{DIFF} > 0,9 V$	L
$0,5 V < V_{DIFF} < 0,9 V$	**
$V_{DIFF} < 0,5 V$	H
Absent	H

* Input difference voltage V_{DIFF} , V is determined by formula

$$V_{DIFF} = V_7 - V_6 \quad , \quad (1)$$
 V_7 – CANH output voltage, V;
 V_6 - CANL output voltage, V
 ** Not determined (hysteresis zone)

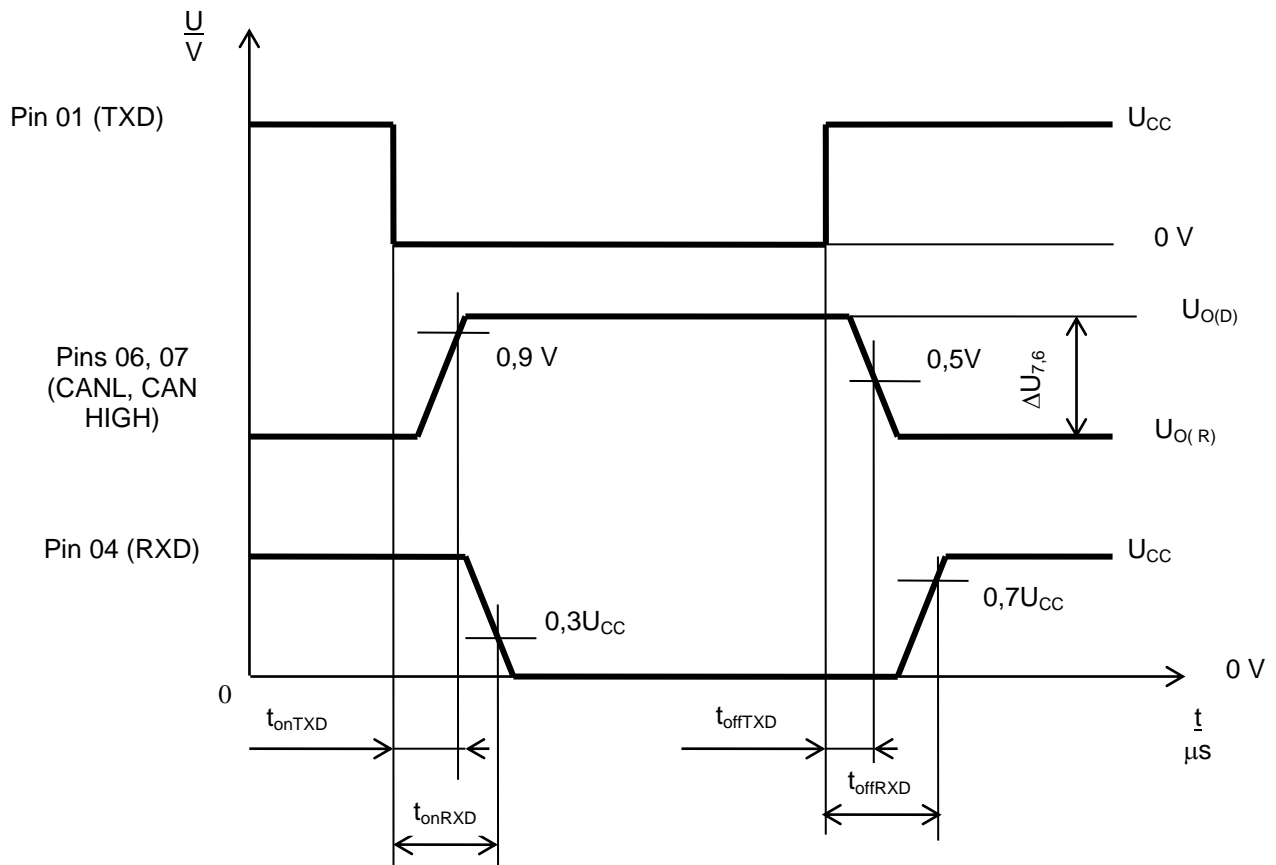

Fig. 4 – t_{onTXD} , t_{onRXD} , t_{offTXD} , t_{offRXD} parameters measurement timing diagram

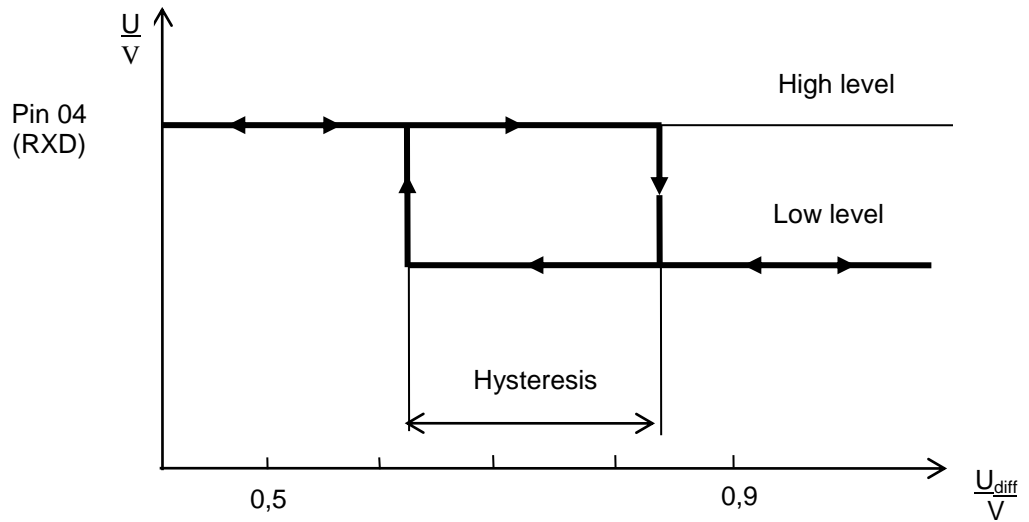

Fig. 5 – $V_{diff(hys)}$ parameter measurement timing diagram

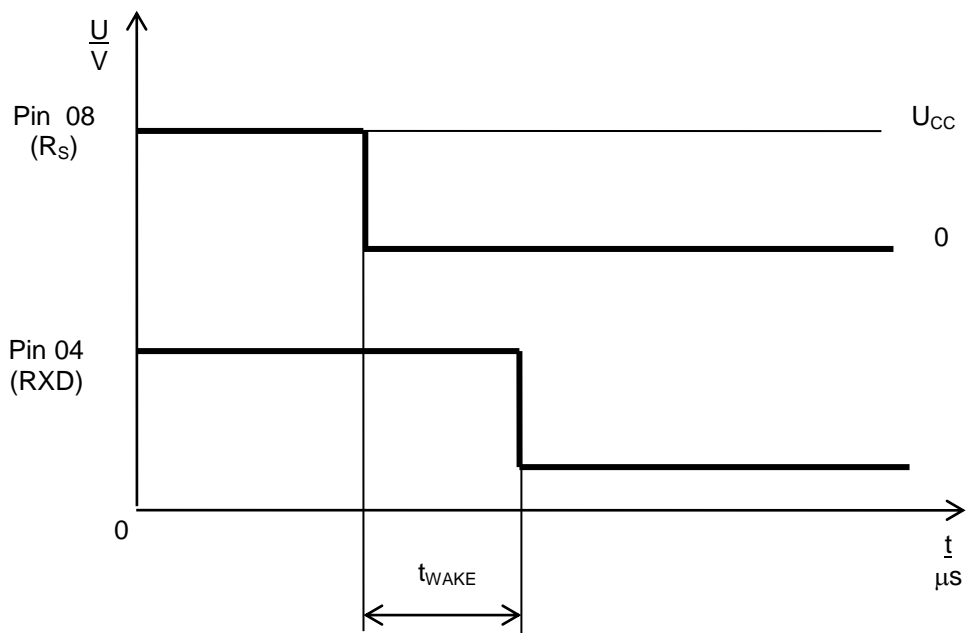
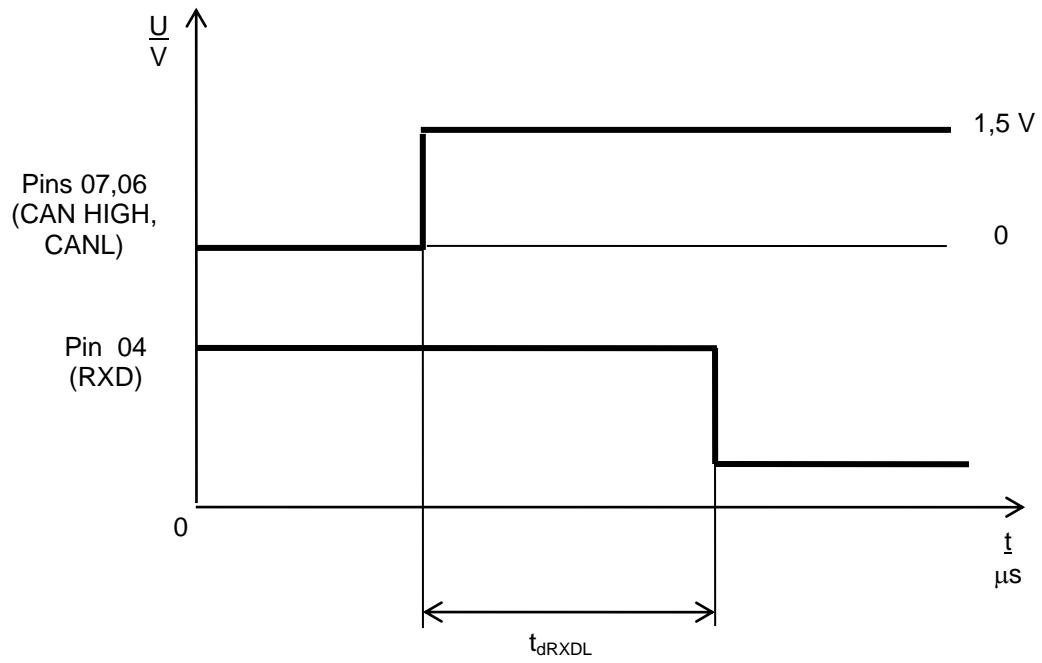

Fig. 6 – t_{WAKE} parameter measurement timing diagram



$$t_{dRXDL} \leq 15 \mu s$$

Fig. 7 – t_{dRXDL} parameter measurement timing diagram

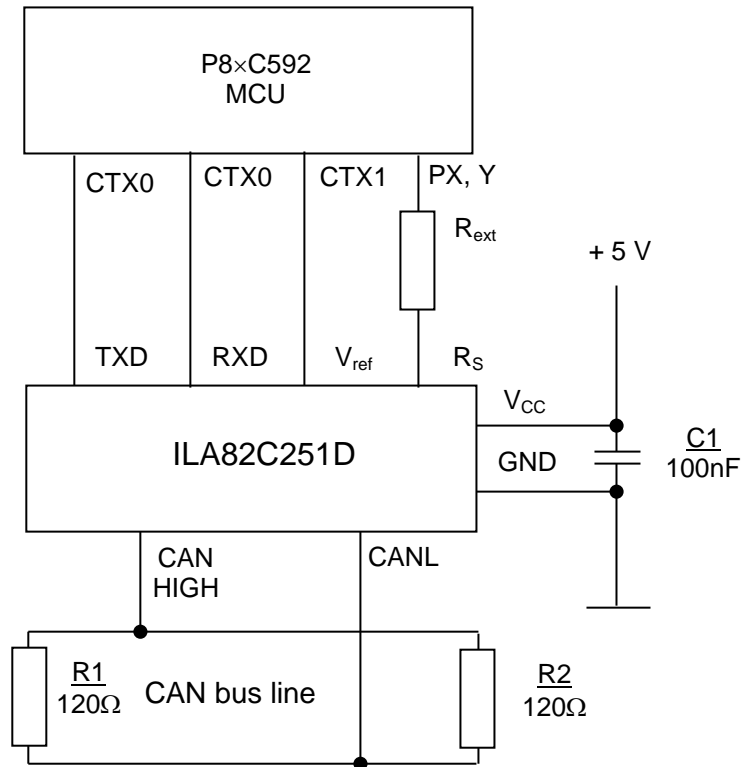
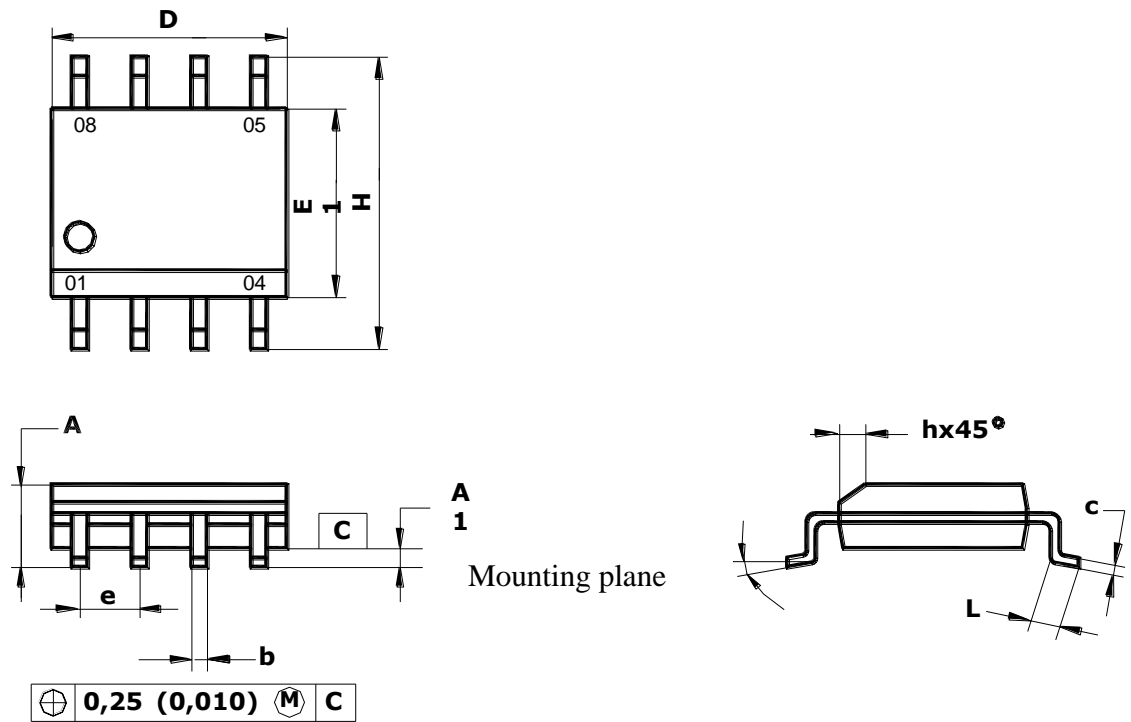

Fig. 8 – Application diagramm

Package Dimensions



	D	E1	H	b	e	α	A	A1	c	L	h
	mm										
min	4.80	3.86	5.84	0.35		0°	1.35	0.10	0.19	0.40	0.25
max	4.95	4.00	6.20	0.51	1.27	8°	1.75	0.25	0.25	0.89	0.50

Fig. 9 –MS-012AA package dimensions

X-ON Electronics

Largest Supplier of Electrical and Electronic Components

Click to view similar products for [CAN Interface IC category](#):

Click to view products by [IKSEMICON manufacturer](#):

Other Similar products are found below :

[IFX1040SJ](#) [416694H](#) [MAX13052ASAT](#) [MAX3057ASAT](#) [MC33742PEP](#) [MCP25025-I/P](#) [MCP25055-I/SL](#) [MCP2561-HMF](#) [MCP2515T-ESO](#) [MCP2561FD-HSN](#) [TJA1042T,118](#) [TJA1050T/CM](#) [TJA1052IT2Y](#) [IL41050TA-1E](#) [ATA6560-GBQW](#) [TJA1042T/1J](#) [TJA1042T/3/1J](#) [TJA1042TCM,118](#) [TJA1042T/CM,118](#) [TJA1051T/CM,118](#) [TJA1051T/E,118](#) [TJA1052IT/5Y](#) [UJA1078ATW/5V0/WDJ](#) [ATA6560-GAQW](#) [ATA6560-GAQW](#) [MCP2561FD-E/SN](#) [MCP25050-E/P](#) [MCP2515-I/ML](#) [SN65LBC031QD](#) [SN65LBC031DG4](#) [SN65HVD267DR](#) [MAX3050ASA+](#) [NCV7342D13R2G](#) [MAX13054ESA+](#) [TJA1050T/CM,118](#) [TJA1040T/CM,118](#) [SJA1000T/N1.118](#) [TJA1051TCM,118](#) [TJF1052IT5Y](#) [TJA1042T31J](#) [TJA1042T/3/CM,118](#) [MCP2562FD-E/P](#) [MAX13052ASA+T](#) [MCP2561-EMF](#) [MCP2561FD-E/P](#) [MCP2562FD-EMF](#) [MCP25025-I/SL](#) [MCP2561FD-H/SN](#) [TLE6251DSXUMA2](#) [LT1796CN8#PBF](#)