

HIGH-VOLTAGE HIGH-CURRENT DARLINGTON TRANSISTOR ARRAYS

ILN2003A

The ILN2003A are monolithic high-voltage, high-current Darlington transistor arrays. Each consists of seven n-p-n Darlington pairs that feature high-voltage outputs with common-cathode clamp diodes for switching inductive loads. The collector-current rating of a single Darlington pair is 500 mA. The Darlington pairs may be paralleled for higher current capability. Applications include relay drivers, hammer drivers, lamp drivers, display drivers (LED and gas discharge), line drivers, and logic buffers.

The ILN2003A has a 2.7-kΩ series base resistor for each Darlington pair for operation directly with TTL or 5-V CMOS devices.

- 500-mA Rated Collector Current (Single Output)
- High-Voltage Outputs . . . 50 V
- Output Clamp Diodes
- Inputs Compatible With Various Types of Logic
- Relay Driver Applications

N SUFFIX
DIP

D SUFFIX
SOP

ORDERING INFORMATION
 ILN2003AN DIP
 ILN2003ADT SOP
 T_A = -40°C to 85°C for all packages

LOGIC SYMBOL

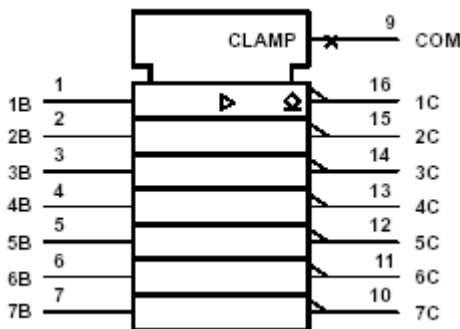

LOGIC DIAGRAM

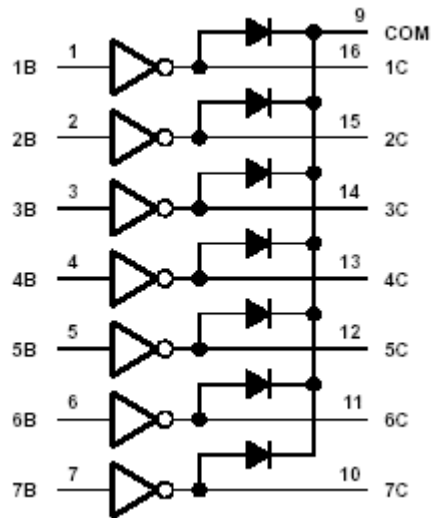

SCHEMATICS (each Darlington Pair)

All resistor values shown are nominal.

ILN2003A: R_B = 2.7 kΩ

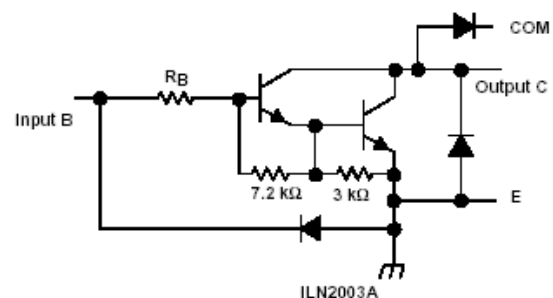

Absolute Maximum Ratings (Ta =25°C)

Parameter	Symbol	Limit Values		Unit	
		min.	max.		
Output Sustaining Voltage	$V_{CE(SUS)}$	-0.5	50	V	
Output Current	I_{OUT}	500		mA/ch	
Input Voltage	V_{IN}	-0.5	30	V	
Clamp Diode Reverse Voltage	V_R	50		V	
Clamp Diode Forward Current	I_F	500		mA	
Power Dissipation	DIP	P_D	1.15		W
	SOP		0.95		
Operating Temperature	T_{opr}	-40	85	°C	
Storage Temperature	T_{stg}	-55	150	°C	

* Stresses beyond those listed under "absolute maximum ratings" may cause permanent damage to the device. These are stress ratings only and functional operation of the device at these or any other conditions beyond those indicated under "recommended operating conditions" is not implied. Exposure to absolute-maximum-rated conditions for extended periods may affect device reliability.

Recommended Operating Conditions (Ta=-40~85°C)

Parameter	Symbol	Test Condition	Limit Value			Unit	
			Min	Typ	Max		
Output Sustaining Voltage	$V_{CE(SUS)}$		0	-	50	V	
Output Current	DIP	I_{OUT}	$T_{pw}=25ms, Duty=10%, 7$ Circuits	0	-	370	mA/ch
			$T_{pw}=25ms, Duty=30%, 7$ Circuits	0	-	200	
	SOP	$T_{pw}=25ms, Duty=10%, 7$ Circuits	0	-	290		
		$T_{pw}=25ms, Duty=30%, 7$ Circuits	0	-	150		
Input Voltage	V_{IN}		0	-	30	V	
Clamp Diode Reverse Voltage	V_R		-	-	50	V	
Clamp Diode Forward Current	I_F		-	-	400	mA	
Power Dissipation	DIP	P_D		-	-	0.52	W
	SOP			-	-	0.4	

Electrical characteristics, $T_A = 25^\circ\text{C}$ (unless otherwise noted)

Parameter	Test Fig.	Test Conditions	Min	Typ	Max	Unit	
$V_{I(\text{on})}$ On-state Input Voltage	6	$V_{CE}=2\text{V}$	$I_C=125\text{mA}$				V
			$I_C=200\text{mA}$			2.4	
			$I_C=250\text{mA}$			2.7	
			$I_C=275\text{mA}$				
			$I_C=300\text{mA}$			3	
			$I_C=350\text{mA}$				
$V_{CE(\text{sat})}$ Collector-emitter saturation voltage	5	$I_F=250\mu\text{A}$	$I_C=100\text{mA}$		0.9	1.1	V
		$I_F=350\mu\text{A}$	$I_C=200\text{mA}$		1	1.3	
		$I_F=500\mu\text{A}$	$I_C=350\text{mA}$		1.2	1.6	
I_{CEX} Collector outoff current	1	$V_{CE}=50\text{V}$	$I_F=0$			50	uA
	2	$V_{CE}=50\text{V}$, $T_A=85^\circ\text{C}$	$I_F=0$ $V_I=1\text{V}$			100	
h_{FE} DC Current Transfer Ratio	5	$V_{CE}=2\text{V}$, $I_{OUT}=350\text{mA}$	1000	-	-		
V_F Clamp forward voltage	8	$I_F=350\text{mA}$		1.7	2	V	
$I_{I(\text{off})}$ Off-state input current	3	$V_{CE}=50\text{V}$ $T_A=85^\circ\text{C}$	$I_C=500\mu\text{A}$	50	65	uA	
I_I Input current	4	$V_I=2.4\text{V}$			0.4	0.7	mA
		$V_I=5\text{V}$					
		$V_I=12\text{V}$					
I_R Clamp reverse current	7	$V_R=50\text{V}$				50	uA
		$V_R=50\text{V}$	$T_A=85^\circ\text{C}$				
C_I Input capacitance		$V_I=0$	$f=1\text{MHz}$		15	25	pF

Switching Characteristics, $T_A=25^\circ\text{C}$

Parameter	Test Conditions	Min	Typ	Max	Unit
t_{PLH} Propagation delay time, low-to-high-level output	See Figure 9		0.25	1	us
t_{PHL} Propagation delay time, high -to- low -level output			0.25	1	us
V_{OH} High-level output voltage after switching	$V_S=50\text{V}$, $I_O=300\text{mA}$, See Figure 10	V_S-20			mV

PARAMETER MEASUREMENT INFORMATION

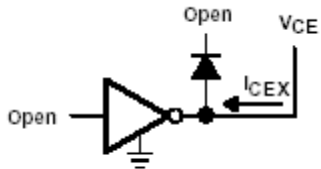

Figure 1. I_{CEX} Test Circuit

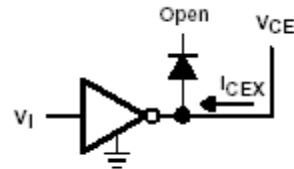

Figure 2. I_{CEX} Test Circuit

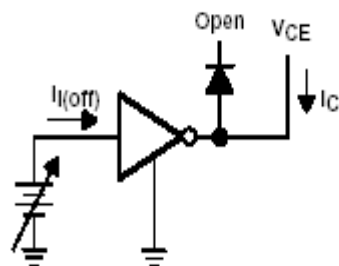

Figure 3. $I_{I(off)}$ Test Circuit

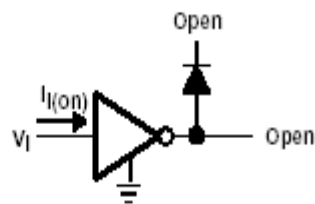
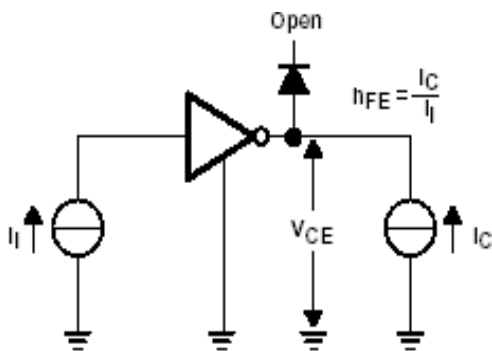

Figure 4. I_I Test Circuit



NOTE: I_I is fixed for measuring $V_{CE(sat)}$, variable for measuring h_{FE} .

Figure 5. h_{FE} , $V_{CE(sat)}$ Test Circuit

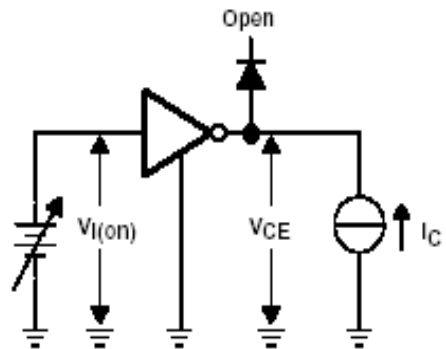

Figure 6. $V_{I(on)}$ Test Circuit

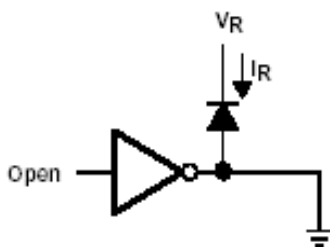

Figure 7. I_R Test Circuit

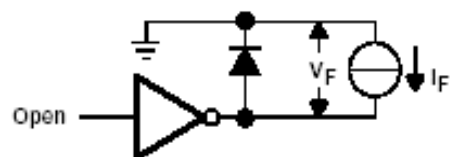

Figure 8. V_F Test Circuit

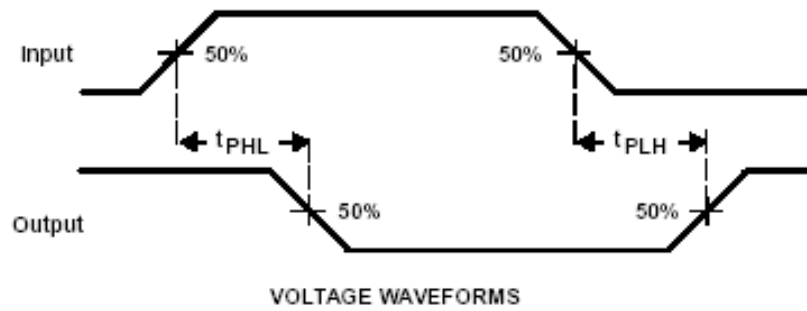
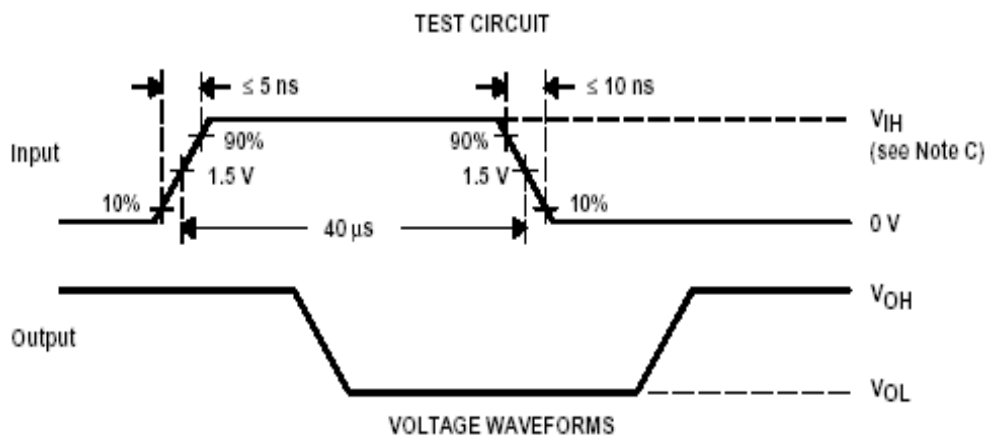

Figure 9. Propagation Delay-Time Waveforms



- NOTES: A. The pulse generator has the following characteristics: PRR = 12.5 kHz, $Z_O = 50 \Omega$.
 B. C_L includes probe and jig capacitance.
 C. $V_{IH} = 3 \text{ V}$;

Figure 10. Latch-Up Test Circuit and Voltage Waveforms

TYPICAL CHARACTERISTICS

COLLECTOR-EMITTER SATURATION VOLTAGE vs COLLECTOR CURRENT (ONE DARLINGTON)

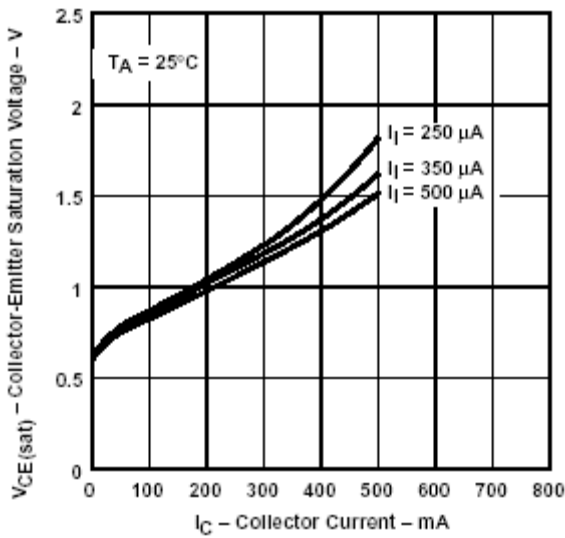

Figure 11

COLLECTOR-EMITTER SATURATION VOLTAGE vs TOTAL COLLECTOR CURRENT (TWO DARLINGTONS PARALLELED)

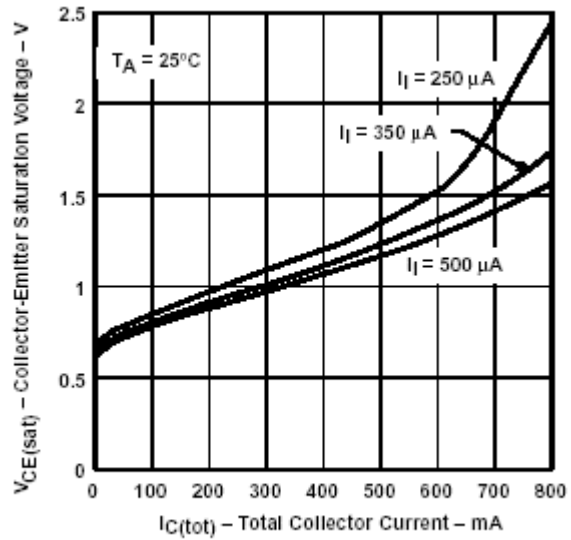

Figure 12

COLLECTOR CURRENT vs INPUT CURRENT

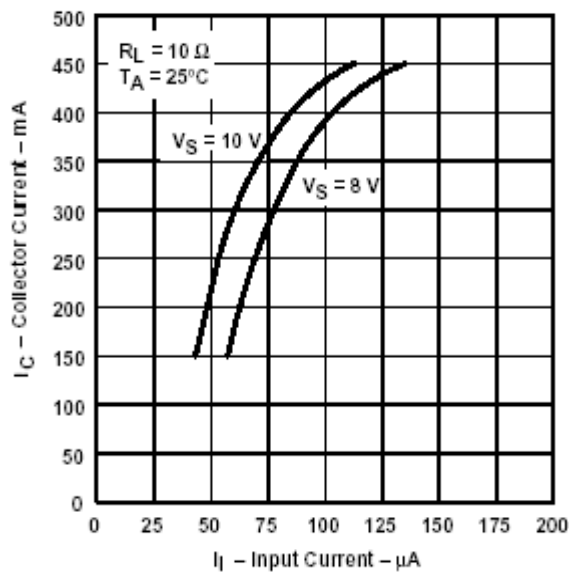

Figure 13

THERMAL INFORMATION

D PACKAGE
MAXIMUM COLLECTOR CURRENT
Vs
DUTY CYCLE

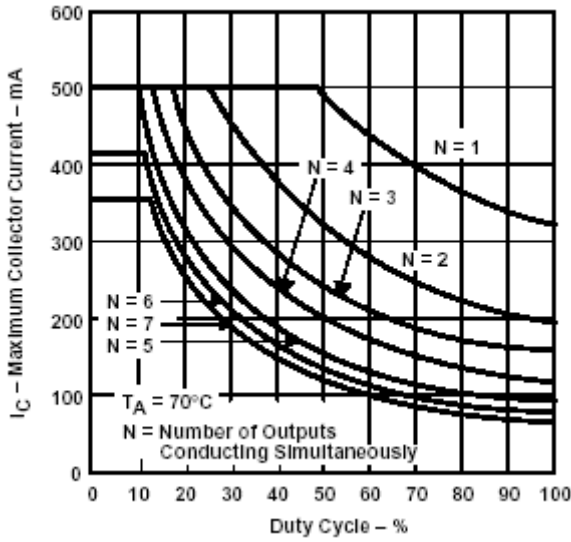

Figure 14

N PACKAGE
MAXIMUM COLLECTOR CURRENT
VS
DUTY CYCLE

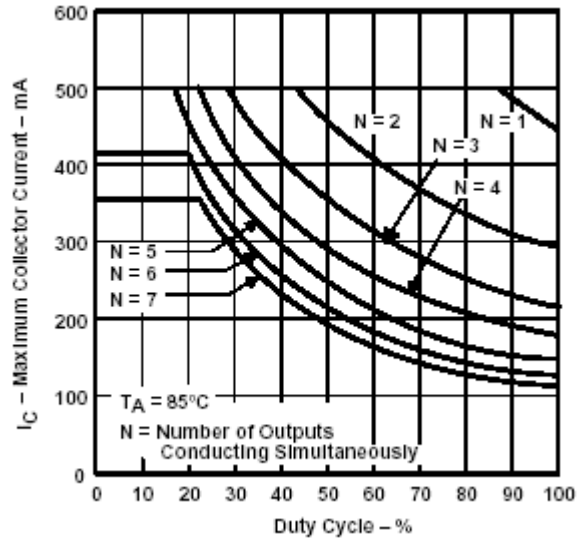
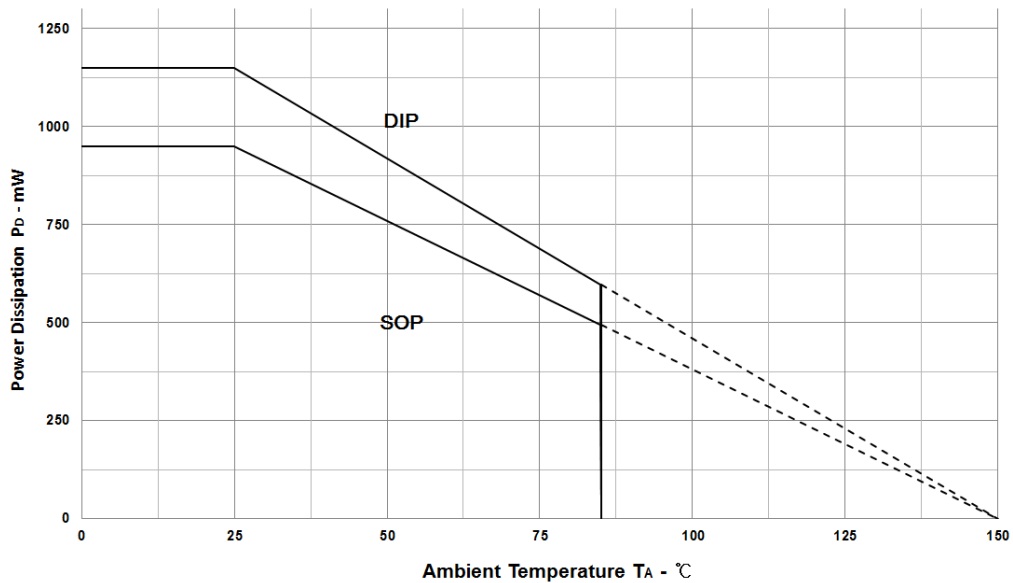

Figure 15

POWER DISSIPATION
VS.
AMBIENT TEMPERATURE



APPLICATION INFORMATION

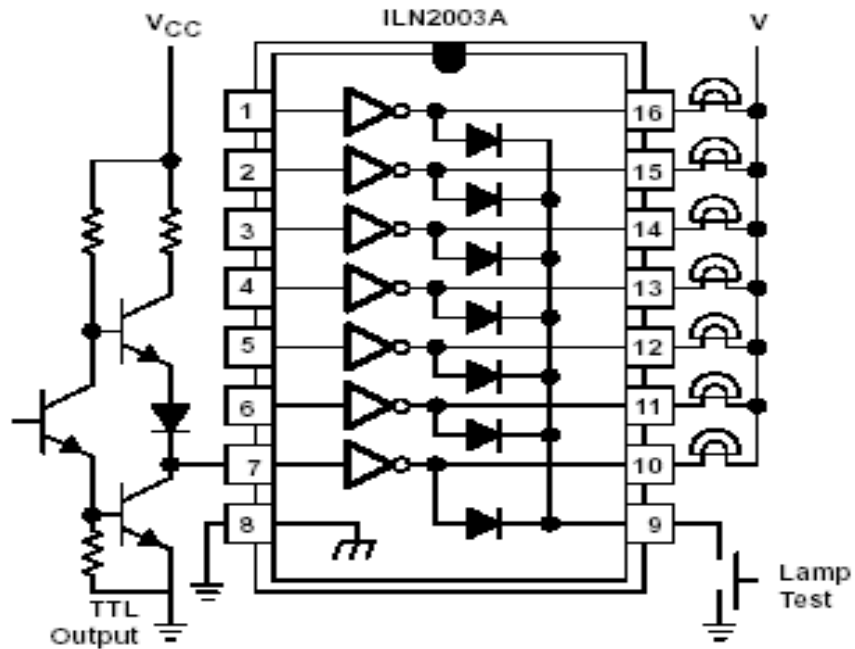

Figure 16. TTL to Load

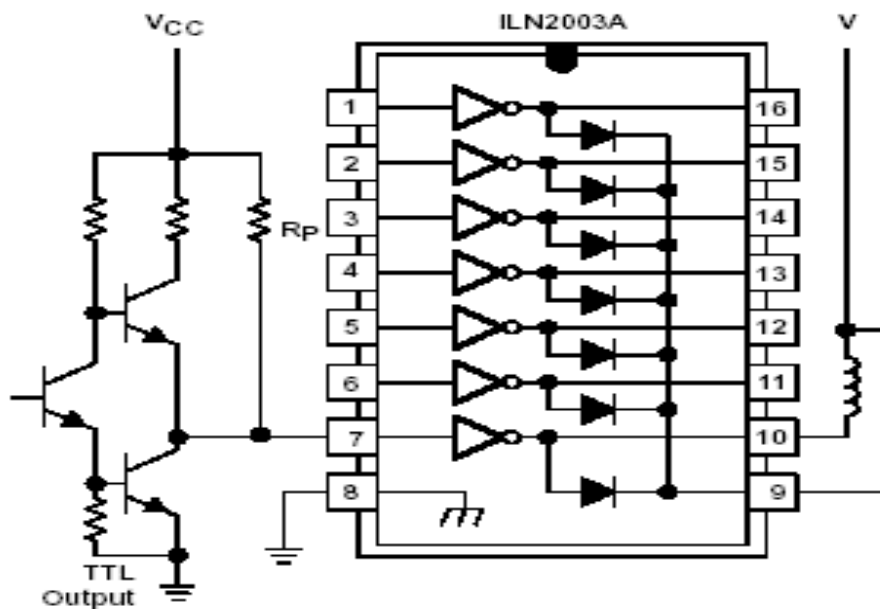
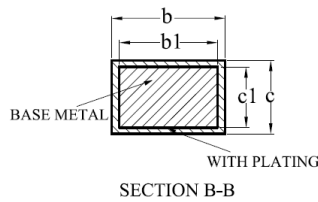
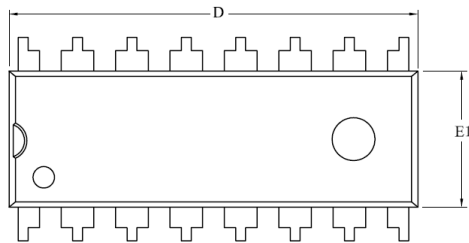
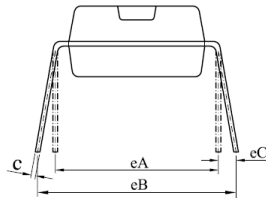
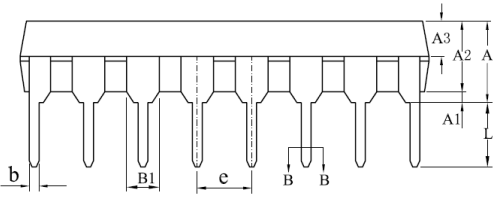

Figure 17. Use of Pullup Resistors to Increase Drive Current

DIP-16



SYMBOL	MILLIMETER		
	MIN	NOM	MAX
A	3.60	3.80	4.00
A1	0.51	—	—
A2	3.10	3.30	3.50
A3	1.42	1.52	1.62
b	0.44	—	0.53
b1	0.43	0.46	0.48
B1	1.52BSC		
c	0.25	—	0.31
c1	0.24	0.25	0.26
D	18.90	19.10	19.30
E1	6.15	6.35	6.55
e	2.54BSC		
eA	7.62BSC		
eB	7.62	—	9.50
eC	0	—	0.94
L	3.00	—	—
L/F载体尺寸 (mil)	80*80		
	110*140		
	140*170		

SOP-16

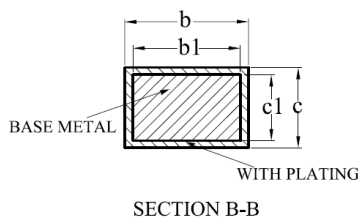
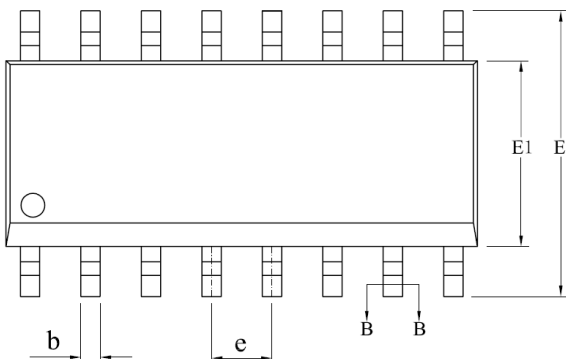
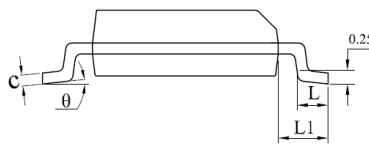
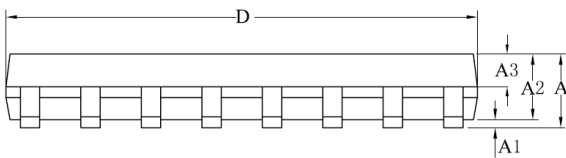

SYMBOL	MILLIMETER		
	MIN	NOM	MAX
A	—	—	1.75
A1	0.10	—	0.25
A2	1.35	1.40	1.45
A3	0.60	0.65	0.70
b	0.39	—	0.48
b1	0.38	0.41	0.43
c	0.21	—	0.26
c1	0.19	0.20	0.21
D	9.70	9.90	10.10
E	5.80	6.00	6.20
E1	3.70	3.90	4.10
e	1.27BSC		
L	0.50	—	0.80
L1	1.05BSC		
theta	0	—	8°
L/F载体尺寸 (mil)	75*75		
	90*110		
	90*180		

X-ON Electronics

Largest Supplier of Electrical and Electronic Components

Click to view similar products for [Darlington Transistors](#) category:

Click to view products by [IKSEMICON](#) manufacturer:

Other Similar products are found below :

[281287X](#) [SMMBT6427LT1G](#) [2N7371](#) [BDV64B](#) [JANTXV2N6287](#) [028710A](#) [SMMBTA64LT1G](#) [2N6350](#) [2SB1214-TL-E](#)
[SMMBTA14LT1G](#) [SBSP52T1G](#) [NJVMJD117T4G](#) [Jantx2N6058](#) [2N6353](#) [LB1205-L-E](#) [500-00005](#) [2N6053](#) [NJVMJD112G](#) [Jan2N6350](#)
[Jantx2N6352](#) [Jantx2N6350](#) [BULN2803LVS](#) [ULN2001N](#) [2SB1383](#) [2SB1560](#) [2SB852KT146B](#) [TIP112TU](#) [TIP122TU](#) [BCV27](#) [MMBTA13-](#)
[TP](#) [MMBTA14-TP](#) [MMSTA28T146](#) [BSP50H6327XTSA1](#) [KSH122TF](#) [NTE2557](#) [NJVNJD35N04T4G](#) [TIP115](#) [MPSA29-D26Z](#) [MJD127T4](#)
[FJB102TM](#) [BCV26E6327HTSA1](#) [BCV46E6327HTSA1](#) [BCV47E6327HTSA1](#) [BSP61H6327XTSA1](#) [BU941ZPFI](#) [2SB1316TL](#) [2SD1980TL](#)
[NTE2350](#) [NTE245](#) [NTE246](#)