

Automotive Grade, 4 Pad 5.0mm x 3.2mm SMD, LVCMOS Oscillator

ISA20 Series

Product Features:

- AEC-Q200 qualified
- IATF 16949 certified production lines
- LVCMOS compatible output
- Industry-standard package 5.0mm x 3.2mm
- Five supply voltages options, 1.8V, 2.5V, 2.8V, 3.0V or 3.3V
- Pb-free, Halogen-free, and Antimony-free
- RoHS and REACH compliant

Typical Applications:

- Navigation, GPS
- Infotainment System
- Instrument Panel, Ethernet
- ADAS, Camera, Engine Control Units
- LIDAR Systems, TPMS

ELECTRICAL SPECIFICATIONS

Frequency Range	1MHz to 156.250MHz 1MHz to 135MHz	Vdd = 2.5V, 2.8V, 3.0V or 3.3V Vdd = 1.8V
Frequency Stability	±50ppm Maximum ±100ppm Maximum	Inclusive of Initial Tolerance, Stability over Operating Temperature Range, Load (±5%), Voltage (±10%), and Aging (First Year at +25°C)
Operating Temperature Range	-40°C to +85°C -40°C to +105°C -40°C to +125°C	
Supply Voltage (Vdd)	1.8V 2.5V, 2.8V, 3.0V or 3.3V	±5% ±10%
Input Current	20mA Maximum	No Load
Output Logic Type	LVCMOS	
Output Drive Capability	15pF Maximum	
Aging	±3ppm/year Maximum	at +25°C
Duty Cycle	50 ±5(%)	Measured at 50% of waveform
Rise / Fall Time	6nSec Maximum	Measured from 20% to 80% of waveform
Output Voltage Logic High	90% of Vdd Minimum	
Output Voltage Logic Low	10% of Vdd Maximum	
Input Voltage Logic High	70% of Vdd Minimum or No Connect to Enable Output	
Input Voltage Logic Low	30% of Vdd Maximum to Disable Output (High Impedance)	
Standby Current	10µA Maximum	Disabled Output, High Impedance
Startup Time	10mSec Maximum	
RMS Period Jitter	5pSec Maximum 6pSec Maximum	Vdd = 2.5V, 2.8V, 3.0V or 3.3V Vdd = 1.8V
Peak-to-Peak Period Jitter	30pSec Maximum 40pSec Maximum	Vdd = 2.5V, 2.8V, 3.0V or 3.3V Vdd = 1.8V
NOTES:	<ul style="list-style-type: none"> • All minimum and maximum limits are specified over temperature and rated operating voltage with 15pF output unless otherwise stated. • A 0.1µF bypass capacitor is recommended between Vdd (pad 4) and GND (pad 2) to minimize power supply noise. 	

ABSOLUTE MAXIMUM LIMITS

Storage Temperature Range	-55°C to +125°C
Supply Voltage Range	-0.3Vdc to Vdd +0.3Vdc
Electrostatic Discharge	2000V Maximum
Solder Temperature	260°C Maximum
Junction Temperature	150°C Maximum
NOTE:	If the part is used beyond absolute maximum ratings, it may cause internal destruction. The part should be used under the recommended operating conditions or the reliability of this part may be damaged if those conditions are exceeded.

PART NUMBER GUIDE

Series	Supply Voltage	Operating Temperature Range	Frequency Stability	Function	Frequency
ISA20-	1 = 1.8V 6 = 2.5V 2 = 2.8V 7 = 3.0V 3 = 3.3V	2 = -40°C to +85°C E = -40°C to +105°C F = -40°C to +125°C	A = ±25ppm B = ±50ppm C = ±100ppm	H = Output Enable	-25.000 MHz

Sample Part Number: ISA20-3FCH-25.000 MHz

- NOTES:**
- Not all Frequency Stability options are available at all frequency and Operating Temperature Ranges.
 - Please consult with Sales Department any other parameters or options.

Automotive Grade, 4 Pad 5.0mm x 3.2mm SMD, LVCMOS Oscillator

ISA20 Series

MECHANICAL & SOLDER PAD LAYOUT DIMENSIONS

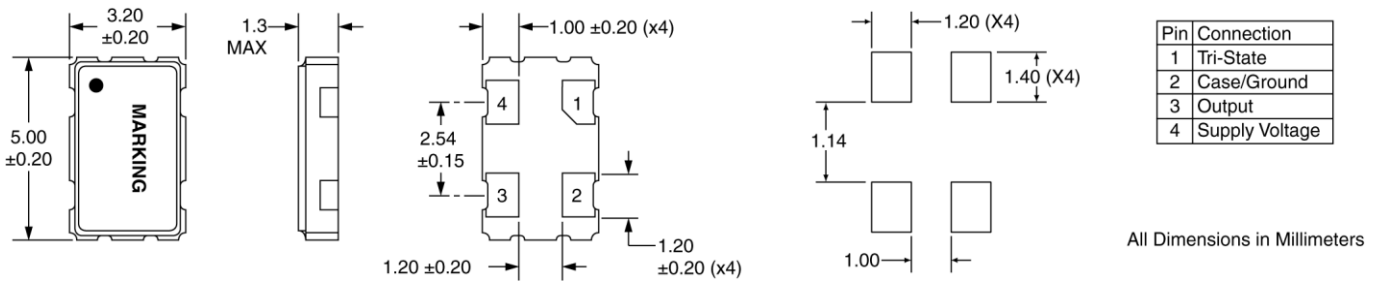

MARKING

Line 1: Frequency (X.XXX or XX.XX or XXX.X)

Line 2: Date Code (YWW)

Pin 1 Dot

PACKAGE INFORMATION

Termination = e4 (Au over Ni over W base metallization)

Terminal Plating Thickness:

Gold (0.3µm to 1.0µm), Nickel (1.27µm to 8.89µm)

ENVIRONMENTAL SPECIFICATIONS

Mechanical Shock	MIL-STD-202, Method 213
Mechanical Vibration	MIL-STD-202, Method 204
Resistance to Soldering Heat	MIL-STD-202, Method 210
Solderability	J-STD-002
Gross Leak	MIL-STD-883, Method 1014
Fine Leak	MIL-STD-883, Method 1014
Moisture Sensitivity Level	MSL 1 (+260°C)

TAPE & REEL DIMENSIONS

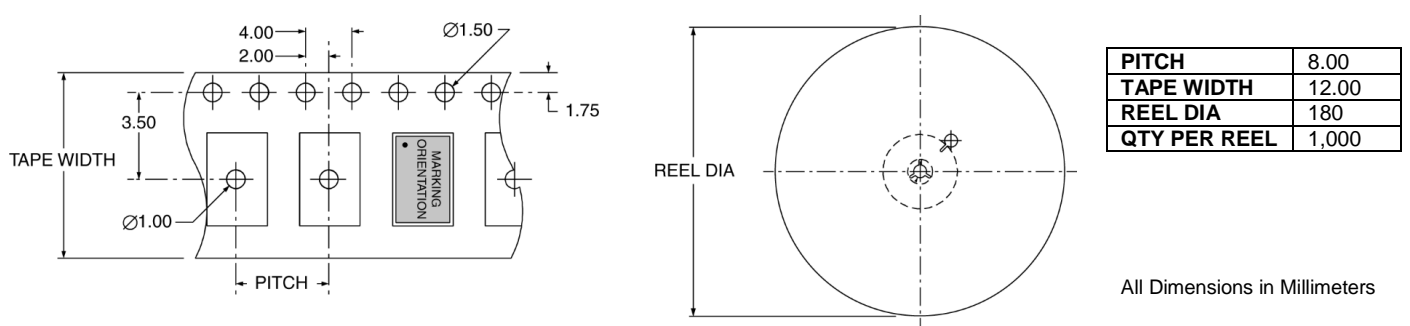

TEST CIRCUIT

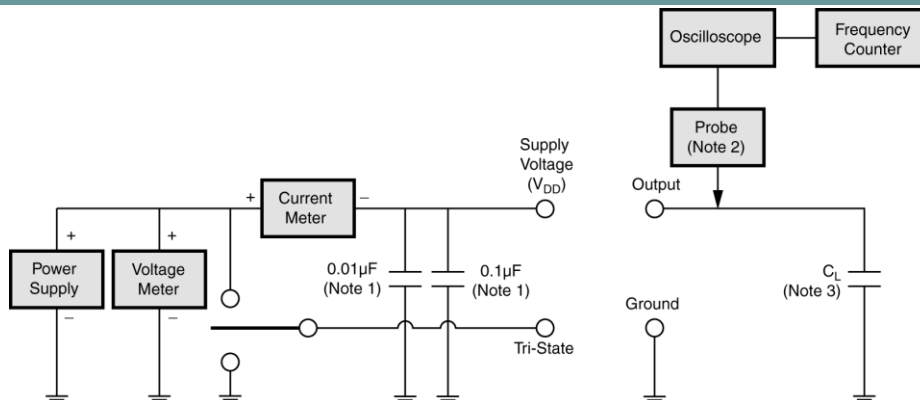

WAVEFORM

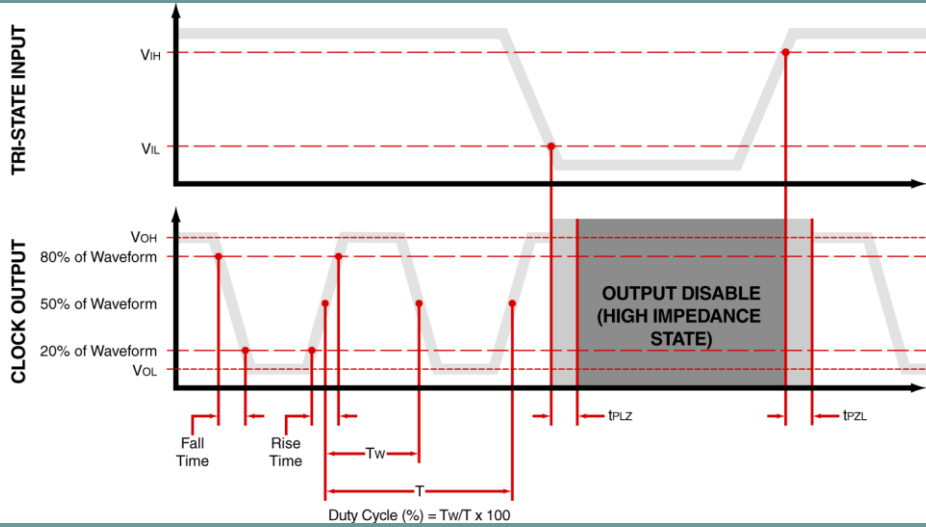

SOLDER REFLOW PROFILE

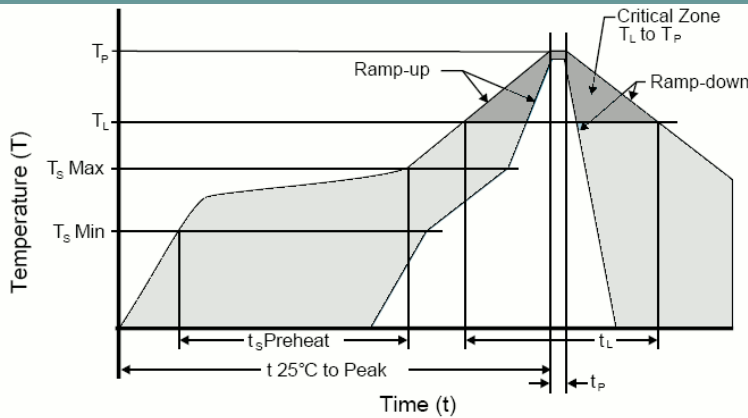

Units are backward compatible with +240°C reflow process

Ts max to TL (Ramp-up Rate)	3°C / second max
Preheat	
Temperature min (Ts min)	150°C
Temperature typ (Ts typ)	175°C
Temperature max (Ts max)	200°C
Time (Ts)	60 to 180 seconds
Ramp-up Rate (TL to TP)	3°C / second max
Time Maintained Above Temperature (TL) Time (TL)	217°C 60 to 150 seconds
Peak Temperature (TP)	260°C max for 10 seconds
Time within 5°C to Peak Temperature (TP)	20 to 40 seconds
Ramp-down Rate	6°C / second max
Tune 25°C to Peak Temperature	8 minute max
Moisture Sensitivity Level (MSL)	Level 1

PROPRIETARY AND CONFIDENTIAL

THIS DOCUMENT CONTAINS PROPRIETARY INFORMATION, AND SUCH INFORMATION MAY NOT BE DISCLOSED TO OTHERS FOR ANY PURPOSE NOR USED FOR MANUFACTURING PURPOSES WITHOUT WRITTEN PERMISSION FROM ILSI America.

X-ON Electronics

Largest Supplier of Electrical and Electronic Components

Click to view similar products for [Crystals](#) category:

Click to view products by [ILSI](#) manufacturer:

Other Similar products are found below :

[CS325S24000000ABJT](#) [718-13.2-1](#) [MC405 32.0000K-R3:PURE SN](#) [FC-135R 32.7680KF-A3](#) [7A-40.000MAAE-T](#) [7B-27.000MBBK-T](#)
[FL2000085](#) [9B-15.360MBBK-B](#) [9C-7.680MBBK-T](#) [ASH7K-32.768KHZ](#) [AT-41.600MAGQ-T](#) [BTD1062E05A-513](#) [LFX TAL066198Cutt](#)
[9C-14.31818MBBK-T](#) [FA-238 50.0000MB30X-K3](#) [FC-12M 32.7680KA-AC3](#) [SSPT7F-9PF20-R](#) [FX325BS-38.88EEM1201](#)
[LFX TAL065253Cutt](#) [LFX TAL066431Cutt](#) [XT9S20ANA14M7456](#) [XT9SNLANA16M](#) [646G-24-2](#) [7A-24.576MBBK-T](#) [7B-30.000MBBK-T](#)
[WX26-32.768K-6PF](#) [9B-14.31818MBBK-B](#) [CD1AM](#) [7B-25.000MAAE-T](#) [7A-14.31818MBBK-T](#) [6504-202-1501](#) [6526-202-1501](#) [FA-118T](#)
[27.1200MB50P-K0](#) [FC-135R 32.7680KA-A3](#) [ABM12-104-37.400MHZT](#) [ABLS-10.000MHZ-D3W-T](#) [BTJ112E01E-513](#) [BTJ722K01C-7067](#)
[BTL-20-513](#) [TSX-3225 24.0000MF15X-AC](#) [TSX-3225 16.0000MF18X-AC](#) [BTJ120E02C](#) [BTL-12-513](#) [7A-10.000MBBK-T](#) [7A-](#)
[11.0592MBBK-T](#) [ABM12-103-24.000MHZT](#) [CS325S25000000ABJT](#) [ABM3B-25.000MHZ-B2-X-T](#) [FC-135 32.7680KA-A5](#) [FX0800015](#)