

DPS422

Digital barometric pressure & temp sensor for portable and IOT devices

V1.3

Description

The DPS422 is a miniaturized digital barometric air pressure sensor with high accuracy and low current consumption, capable of measuring both pressure and temperature. Pressure sensing is carried out using a capacitive sensor element, guaranteeing high accuracy over temperature. The small 2.0 x 2.5 x 0.73 mm package makes the DPS422 ideal for mobile applications and wearable devices.

The pressure and temperature sensor elements are measured by a 24-bit $\Sigma\Delta$ ADC. Measurement results can be accessed over I2C or SPI, with an optional configurable interrupt and a result FIFO capable of holding 32 pressure and/or temperature measurements.

Individual calibration coefficients are generated for each unit during testing, and stored in the fuse registers. These coefficients are used in the application to convert the measurement results to high accuracy pressure and temperature values.

Features

- **Operation range:** Pressure: 300 –1200 hPa. Temperature: -40°C – +85 °C.
- **Pressure sensor precision:** ± 0.005 hPa (or ± 5 cm) (high precision mode).
- **Relative accuracy:** ± 0.06 hPa (or ± 50 cm)
- **Absolute accuracy:** ± 1 hPa (or ± 8 m)
- **Temperature accuracy:** $\pm 0.4^\circ\text{C}$.
- **Pressure temperature sensitivity:** $< 0.5\text{Pa/K}$
- **Measurement time: Typical:** 27.6 ms for standard mode (16x). Minimum: 3.6 ms for low precision mode.
- **Average current consumption:** 1.7 μA for pressure measurement, 2 μA for temperature measurement @1Hz sampling rate, Standby: <1 μA .
- **Supply voltage:** VDDIO: 1.2 – 3.6 V, VDD: 1.7 – 3.6 V.
- **Operating modes:** Command (manual), Background (automatic), and Standby.
- **Calibration:** Individually calibrated with coefficients for measurement correction.
- **FIFO:** Stores up to 32 pressure or temperature measurements. Streaming or stop-on-full mode. Optional interrupt on full or watermark interrupt.
- **Interface:** I²C with optional interrupt, 4-wire SPI, 3-wire SPI with optional interrupt.
- **Package dimensions:** 8-pin LGA, dimensions: 2.0 x 2.5 x 0.73 mm (typ).
- **Green Product (RoHS) Compliant**



Typical applications

- **Local weather station and Thermostat** (Micro weather forecasting; room temperature control)
- **Air flow control** (Smart filter replacement, e.g. in whitegoods; Servers CPU ventilation control)
- **Health and sports** (Accurate elevation gain and vertical speed detection, e.g. for smart watches)
- **Outdoor navigation** (GPS start-up time and accuracy improvement; dead-reckoning e.g. in tunnels)
- **Indoor navigation** (Floor detection e.g. in shopping malls and parking garages)
- **Smart Home** (Intruder detection and environmental monitoring of premises)**C**

Product validation

Qualified for industrial applications according to the relevant tests of JEDEC47/20/22.

Definitions

An explanation of the terms and definitions used in this datasheet.

Table 1 DPS422 Defintions

Term	Definition/explanation
Absolute accuracy	The absolute measurement accuracy over the entire measurement range.
Digital bit depth	The total bit depth used for conversion of the sensor input to the digital output. Measured in bits.
Digital resolution	The pressure value represented by the LSB change in output. This value should be much smaller than the sensor noise.
Full Scale Range (FSR)	The peak-to-peak measurement range of the sensor.
LSB	Least Significant Bit
Measurement time	The time required to acquire one sensor output result. This value determines the maximum measurement rate.
MSB	Most Significant Bit
Non-linearity	The deviation of measured output from the best-fit straight line, relative to 1000 hPa and 25 °C.
Output compensation	The process of applying an algorithm to the sensor output to improve the absolute accuracy of the sensor across temperature and to minimize unit to unit output variation. This algorithm makes use of both the temperature sensor readings and the individual calibration coefficients.
Precision (noise)	The smallest measurable change, expressed as rms, after sensor oversampling.
Pressure temperature coefficient	The pressure measurement deviation, after compensation, from expected measurement value due to temperature change from 25 °C. Measured in Pa/K.
Sensor calibration	The process, during the production test, where the sensor's measurement results are compared against reference values, and a set of calibration coefficients are calculated from the deviation. The coefficients are stored in the sensor's memory and are used in the output compensation.
Sensor oversampling rate (OSR)	Specifies the number of sensor measurements used internally to generate one sensor output result.

Table of contents

	Description	1
	Features	1
	Typical applications	1
	Product validation	2
	Definitions	2
	Table of contents	3
1	Block diagram	5
2	Pin configuration	5
3	Specifications	6
3.1	Operating range	6
3.2	Absolute maximum ratings	6
3.3	Current consumption	7
3.4	Pressure transfer function	8
3.5	Temperature transfer function	9
3.6	Timing characteristics	9
4	Functional description	10
4.1	Operating modes	10
4.2	Mode transition diagram	11
4.3	Measurement precision and rate	12
4.3.1	Oversampling rate: kP	12
4.4	FIFO operation	13
4.5	Interrupt	14
4.6	Start-up sequence	14
4.7	Sensor interface	14
5	Pressure measurement	16
5.1	Pressure measurement results	16
5.1.1	Calculating pressure reading	16
6	Temperature measurement	18
6.1	One time calculation of A' and B' coefficients	18
6.2	Calculating temperature output using A' and B'	19
6.3	A' and B' calculation constants	19
7	Applications	20
7.1	Measurement settings and use case examples	20
7.2	Application circuit examples	20
8	Digital interfaces	23

Table of contents

8.1	I2C interface	23
8.2	SPI interface	24
8.3	Interface parameter specification	25
8.3.1	General interface parameters	25
8.3.2	I2C timing parameters	27
8.3.3	SPI timing parameters	28
9	Register map	29
10	Register descriptions	30
10.1	PSR_B2	30
10.2	PSR_B1	30
10.3	PSR_B0	30
10.4	TMP_B2	31
10.5	TMP_B1	31
10.6	TMP_B0	31
10.7	PSR_CFG	33
10.8	TEMP_CFG	35
10.9	MEAS_CFG	36
10.10	CFG_REG	37
10.11	INT_STS	38
10.12	WM_CFG	39
10.13	FIFO_STS	40
10.14	RESET	41
10.15	PROD_ID	41
11	Calibration coefficients	42
11.1	Coefficient number formats	44
12	Package description	45
12.1	Package drawing	45
	Revision history	45
	Disclaimer	46

Block diagram

1 Block diagram

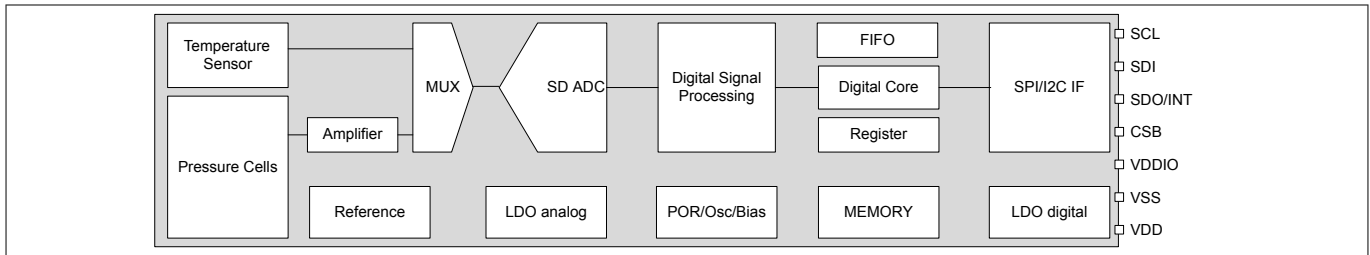

Figure 1 DPS422 block diagram.

2 Pin configuration

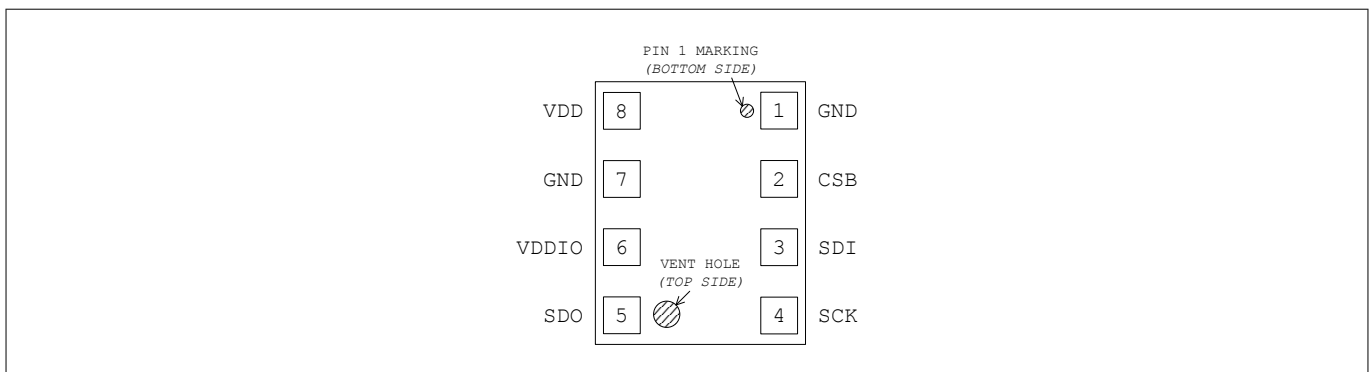

Figure 2 DPS422 pin layout (top view)

Table 2 Pin description

Pin	Name	SPI 3-wire	SPI 3-wire with interrupt	SPI 4-wire	I ² C	I ² C with interrupt
1	GND	Ground				
2	CSB	Chip select - active low	Chip select - active low	Chip select - active low	Not used - open (internal pull-up) or tie to VDDIO	Not used - open (internal pull-up) or tie to VDDIO
3	SDI	Serial data in/out	Serial data in/out	Serial data in	Serial data in/out	Serial data in/out
4	SCK	Serial Clock				
5	SDO	Not used	Interrupt	Serial data out	Least significant bit in the I ² C address.	Interrupt and least significant bit in the I ² C address. ¹⁾
6	VDDIO	Digital supply voltage for digital blocks and I/O interface				
7	GND	Ground				
8	VDD	Supply voltage for analog blocks				

1) Address pin state detected on start-up only. Internal pull up resistor maintains a high logic level on start-up if pin is not connected. Internal pull up resistor is disabled after start-up if a logic low state is detected (due to external pull down), or if the interrupt output is enabled.

Specifications

3 Specifications

3.1 Operating range

The following operating conditions must not be exceeded in order to ensure correct operation of the device. All parameters specified in the following sections refer to these operating conditions, unless noted otherwise.

Table 3 Operating range

Parameter	Symbol	Values			Unit	Note / Test Condition
		Min.	Typ.	Max.		
Pressure	P_a	300		1200	hPa	
Temperature	T_a	-40		85	°C	
Supply voltage	V_{DD}	1.7		3.6	V	
Supply voltage IO	V_{DDIO}	1.2		3.6	V	
Supply voltage ramp-up time	t_{vddup}	0.001		5	ms	Time for supply voltage to reach 90% of final value.
Solder drift ¹			0.5		hPa	Drift measured 72 hours after reflow. Minimum solder height 50um.
Long term stability			±1		hPa	12 months

¹Note: Device might drift out of spec after soldering reflow or when it is exposed to extreme temperature conditions but it is expected to return back into spec after 72hours and completely recover after 168h. Also pressure hysteresis might seen after exposed to temperature cycling but sensor absolute pressure error remains within spec.

3.2 Absolute maximum ratings

Maximum ratings are absolute ratings. Exceeding any one of these values may cause irreversible damage to the integrated circuit.

Attention: *Stresses above the values listed as "Absolute Maximum Ratings" may cause permanent damage to the device. Exposure to absolute maximum rating conditions for extended periods may affect device reliability.*

Table 4 Absolute maximum ratings

Parameter	Symbol	Values			Unit	Note / Test Condition
		Min.	Typ.	Max.		
V_{DD} and V_{DDIO}	V_{DDxx_max}			4	V	
Voltage on any pin	V_{max}			4	V	
Storage temperature	T_s	-40		125	°C	
Pressure	P_{max}			10,000	hPa	
ESD	V_{ESD_HBM}	-2		2	KV	HBM (JS-001)

Specifications

3.3 Current consumption

Test conditions (unless otherwise specified in the table): $V_{DD} = 1.8V$ and $V_{DDIO} = 1.8V$.

Table 5 Current consumption

Parameter	Symbol	Values			Unit	Note / Test Condition
		Min.	Typ.	Max.		
Peak Current Consumption	I_{peak}		345		μA	during Pressure measurement
			280		μA	during Temperature measurement
Standby Current Consumption	I_{stb}		1		μA	
Current Consumption. (1 measurement per second.)	I_{1Hz}		3.2		μA	Low precision
			17			Standard precision
			44			High precision

Note: The current consumption depends on both pressure measurement precision and rate. Please refer to the register description for an overview of the current consumption in different combinations of measurement precision and rate.

Specifications

3.4 Pressure transfer function

Test conditions (unless otherwise specified in the table): $V_{DD}=1.8V$ and $V_{DDIO}=1.8V$. Typ. values ($P_A=1000hPa$ and $T_A=25^\circ C$).

Table 6 Pressure sensor transfer function

Parameter	Symbol	Values			Unit	Note / Test Condition
		Min.	Typ.	Max.		
Absolute pressure accuracy	A_{p_abs}		+/-100		Pa	$P_A=300-1200hPa$ $T_A=25...+65^\circ C$, excluding solder effects
			+/-300		Pa	$P_A=300-1200hPa$ $T_A=-10...+25^\circ C$, excluding solder effects
Relative pressure accuracy	A_{p_rel}		+/-6		Pa	Any $\Delta 25$ hPa in the range $P_A=800-1200hPa$ Any constant temperature in the range $T_A=20...+60^\circ C$
Pressure precision	A_{p_prc}		5.0		Pa_{RMS}	Low Power
			1.2			Standard
			0.5			High Precision

Note: Pressure precision is measured as the average standard deviation. Please refer to the PSR_CFG register description for all precision mode options.

Power supply rejection	A_{p_psr}			TBD	Pa_{RMS}	50mV _{pp} sine wave, sweep from 100Hz to 5MHz
Pressure temperature sensitivity of calibrated measurements	A_{p_tmp}		0.5		Pa/K	1000hPa, 25...+40°C.
Pressure data resolution	A_{p_res}			0.06	Pa_{RMS}	
Pressure measurement rate	f	1		128	Hz	
Pressure measurement time (including 1x decimation temperature measurement)	t		8.8		ms	Low Power (1x decimation)
			32.8			Standard (16x decimation)
			119.2			High Precision (64x decimation)

Note: The pressure measurement time (and thus the maximum rate) depends on the pressure measurement precision. Please refer to the PSR_CFG register description for an overview of the possible combinations of measurement precision and rate.

Specifications

3.5 Temperature transfer function

Test conditions (unless otherwise specified in the table): $V_{DD} = 1.8V$ and $V_{DDIO} = 1.8V$. Typ. values: $T_A = 25^\circ C$. Max./Min. values: $T_A = -10^\circ C \dots +50^\circ C$.

Table 7 Temperature transfer function

Parameter	Symbol	Values			Unit	Note / Test Condition
		Min.	Typ.	Max.		
Temperature absolute error	A_t			± 0.4	$^\circ C$	
Temperature data resolution	A_{t_res}		0.008		$^\circ C$	
Temperature measurement rate	f	1		64	Hz	

3.6 Timing characteristics

Table 8 Timing characteristics

Parameter	Symbol	Values			Unit	Note / Test Condition
		Min.	Typ.	Max.		
Start-up timing						
Time to sensor ready	T_{Sensor_rdy}			8	ms	The SENSOR_RDY bit in the Measurement Configuration register will be set when the sensor is ready.

Note: Start-up timing is measured from $V_{DD} > 1.2V$ & $V_{DDIO} > 0.6V$ or full soft reset.

I ² C Clock.	f_{I2C}			3.4	MHz	
SPI Clock	f_{SPI}			10	MHz	

4 Functional description

The DPS422 is a versatile sensor, capable of providing fast, accurate pressure and temperature measurements at low current. In order to best support a wide range of applications there are a small number of configurable features which can be easily and quickly set on device start up.

The DPS422 configurable features are:

- Operating mode:
 - Command Mode (single-shot)
 - Background Mode (periodic)
 - Standby Mode
- Pressure measurement precision and rate
- Temperature measurement precision and rate
- FIFO settings:
 - FIFO on/off
 - FIFO behaviour: stop-on-full/ streaming
 - FIFO depth
 - FIFO watermark level
- Interrupt behaviour:
 - New measurement result available
 - FIFO full to watermark level
 - FIFO full
 - No interrupt

The precision and measurement rate of the pressure and temperature measurements can be set independently by writing to the PSR_CFG and TEMP_CFG registers. The precision and measurement rates used are dictated by the requirements of the application, and a balance must be found between high precision and low power consumption.

4.1 Operating modes

The DPS422 supports 3 different modes of operation:

- Standby Mode:
 - Default mode after power on or reset. No measurements are performed.
 - All registers and compensation coefficients are accessible.
- Command Mode:
 - One pressure and/or temperature measurement is performed according to the selected precision.
 - The sensor will return to Standby Mode when the measurement is finished, and the measurement result will be available in the dedicated result registers or FIFO output registers.
 - The FIFO can be used when the DPS422 is in Command mode. Several measurements can be requested before reading data back from the FIFO.
- Background Mode:
 - Pressure and/or temperature measurements are performed continuously according to the selected measurement precision and rate. If enabled, the temperature measurement is performed immediately after the pressure measurement.
 - After each measurement is completed, the result will be available in the dedicated result registers if the FIFO is disabled. If the FIFO is enabled it will be added to the FIFO.
 - The FIFO can be used to store up to 32 measurement results and minimize the number of times the sensor must be accessed to read out the results. Using background mode and FIFO streaming mode, the DPS422 measures continuously and the most recent 32 measurements can be read at any time.

Functional description

- The FIFO behaviour can be configured to either stop-on-full mode, which stops recording data once the FIFO is full, or to streaming mode, which will continue recording data once the FIFO is full, deleting the oldest data each time a new measurement is recorded.

Attention: *Switching power mode from Background Mode to Standby Mode is initiated by setting the measurement control bits [2:0] in MEAS_CFG to 0. If a measurement is taking place when these bits are set, the DPS422 will complete the measurement before switching power modes. The value of the Continuous Mode Flag, bit [6] in MEAS_CFG, will update to 0 once this measurement has been completed and the DPS422 has returned to Standby Mode. This bit can be monitored after initiating a power mode change if confirmation of the mode change is required.*

4.2 Mode transition diagram

The mode transition diagram is shown below.

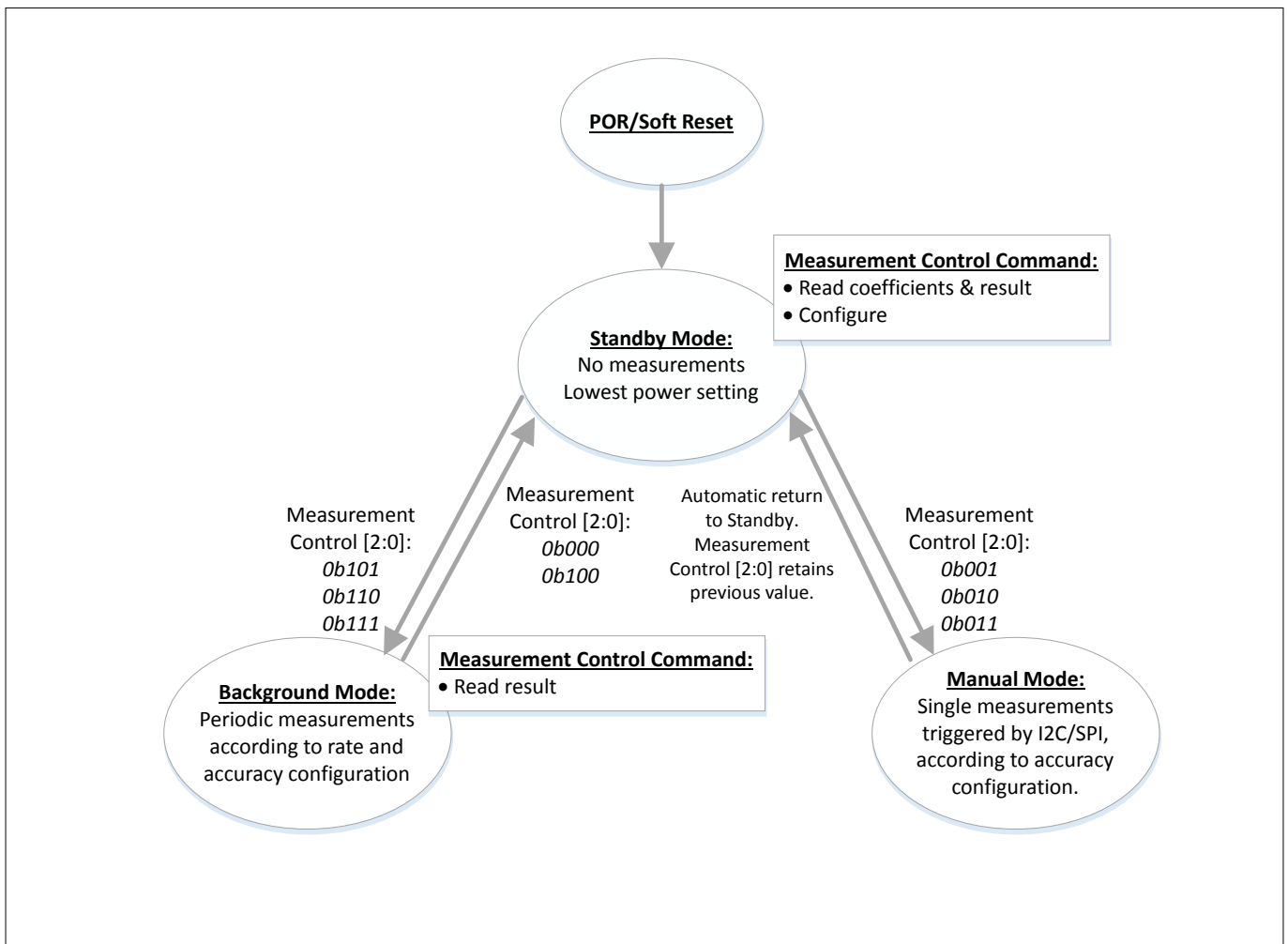

Figure 3 DPS422 mode transition diagram.

4.3 Measurement precision and rate

When the DPS422 is in Background mode, the measurement precision and rate can be configured to match the requirements of the application. This reduces current consumption of the sensor and the system.

In order to achieve a higher precision, the DPS422 will read the sensor multiple times (oversampling), and combine the readings into one result. This increases the current consumption and also the measurement time, reducing the maximum possible measurement rate. It is necessary to balance the accuracy and data rate required for each application with the allowable current consumption.

The measurement precision, rate and time are set in the PSR_CFG and TEMP_CFG. The register descriptions contain information about the current consumption and the possible combinations of measurement precision, time, and rate.

Temperature measurements must be enabled for the DPS422 to compensate for temperature drift in the pressure measurement. The rates of these measurements can be set independently, but temperature compensation is more accurate when temperature and pressure measurements are taken together. This reduces the maximum pressure measurement rate:

$$Rate_{temperature} * Time_{temperature} + Rate_{pressure} * Time_{pressure} < 1 \text{ second.}$$

[Measurement settings and use case examples](#) contains a table with examples of combinations of pressure and temperature precision and rates for different use cases.

The figure below show the temperature and pressure measurement sequence in Background mode.

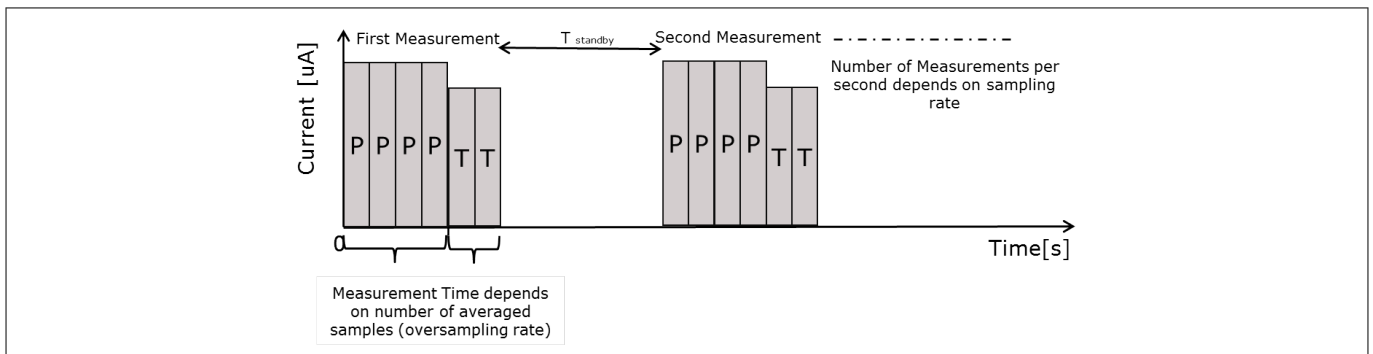

Figure 4 Background mode temperature and pressure measurements sequence

4.3.1 Oversampling rate: kP

Increasing the pressure or temperature oversampling rate increases the number of times the ΣΔ ADC will sample and average the input before generating an output value.

Increasing the oversampling rate improves the measurement accuracy by reducing noise, but it also extends the length of time required to carry out a measurement. Increasing the measurement time increases average current consumption, as the DPS422 will spend longer in full power mode, and less time in standby mode. A balance must be found between current consumption and measurement accuracy, depending on the application requirements.

Increasing the OSR is a good way to remove high frequency noise, but if the measurement time is too long, there will also be a filtering effect on transient pressure events such as spikes caused by doors or windows opening. If the application requires the DPS422 to detect these events, the oversampling rate should not be set too long. The oversampling rate will also have no effect on low frequency fluctuations caused by unstable ambient pressure.

When calculating the pressure measurement from the output register value, it is necessary to include a calculation factor called kP. The value of kP changes depending on the oversampling rate selected for the measurement. The table below lists the oversampling rates and the respective kP values.

Functional description

Table 9 kP values associated with each oversampling rate

Bit Field Value	No. Samples	kP
000	256	524288
001	512	1572864
010	1024	3670016
011	2048	7864320
100	4096	253952
101	8192	516096
110	16384	1040384
111	32768	2088960

The kP values are used in the pressure calculation in the sections:

- [Calibration coefficients](#)

4.4 FIFO operation

The DPS422 FIFO can store up to the last 32 measurements of pressure and/or temperature. This reduces the overall system power consumption as the host processor does not need to continuously poll data from the sensor but can go into standby mode for longer periods of time.

The FIFO can store any combination of pressure and temperature results, according to the background mode measurement rate settings.

The least significant bit of the FIFO measurement result register PSR_B0 is used to indicate whether the measurement is a pressure or temperature result. The least significant bit is set to:

- '1' if the result is a pressure measurement.
- '0' if it is a temperature measurement.

Note: The sensor uses 24 bits to store the measurement result, which is more than is necessary to cover the full dynamic range of the pressure sensor. Using the least significant bit to label the measurement type does not affect the precision of the result.

The FIFO can be enabled in the CFG_REG. The data from the FIFO is read out from PSR_B2, PSR_B1 and PSR_B0 regardless of whether the result in the FIFO is a temperature or a pressure measurement.

When a measurement has been read, the FIFO will automatically increment and place the next result in the data register. The *FIFO empty* bit is set in FIFO_STS when the FIFO is empty, in this case all FIFO reads return 0x800000.

If the FIFO is full, the *FIFO interrupt Full/WM* bit in the FIFO_STS register is set. If the *Interrupt select [3:0]* bits in the CFG_REG register are set to 0x08, an interrupt will also be generated when the FIFO is full.

If the FIFO watermark interrupt is configured by setting the *Interrupt select [3:0]* bits in the CFG_REG register to 0x04, the FIFO will generate an interrupt when the number of pressure and temperature results stored in the FIFO equals the configured watermark level.

The FIFO can be configured to one of two behaviours when full:

- FIFO stops recording new measurement results when full.
- FIFO continues recording new measurement results when full, overwriting the oldest measurement.

This behaviour can be configured by setting the *FIFO Stop on full* bit in the CFG_REG register. Setting this bit to 0 will enable streaming mode, setting to 1 will enable stop-on-full mode.

Functional description

Attention: *It is recommended not to poll the FIFO full flag bit in register INT STS faster once every 375 μs, as it is not updated immediately. Similarly the FIFO full status bit in register FIFO_STS should only be polled once every 250 μs.*

4.5 Interrupt

The DPS422 has a user configurable interrupt, which is generated on the SDO output.

The DPS422 can be configured to generate an interrupt on the following events:

- New measurement result available
- FIFO full to configured watermark level
- FIFO full

The sensor uses the SDO output for the interrupt signal. The interrupt is not supported if the interface is 4-wire SPI.

The interrupt is enabled and configured in the CFG_REG register. In I²C mode SDO serves as both interrupt and as the least significant bit in the device address. SDO has an internal pull up resistor, which defaults the address selection functionality to 0x77.

The SDO output has a push-pull output stage so there is no need to use an external pull down resistor if the default I²C address is suitable for the application. Active high or active low interrupt operation can be selected using the Interrupt polarity bit, bit [3] in the CFG_REG register.

Note: An external pull up resistor is never required on SDO and should not be used.

The interrupt status can be read from the INT STS register.

4.6 Start-up sequence

The DPS422 start-up sequence is shown below. This diagram shows when the registers are accessible for read/write operations and also when the pressure/temperature measurements can start.

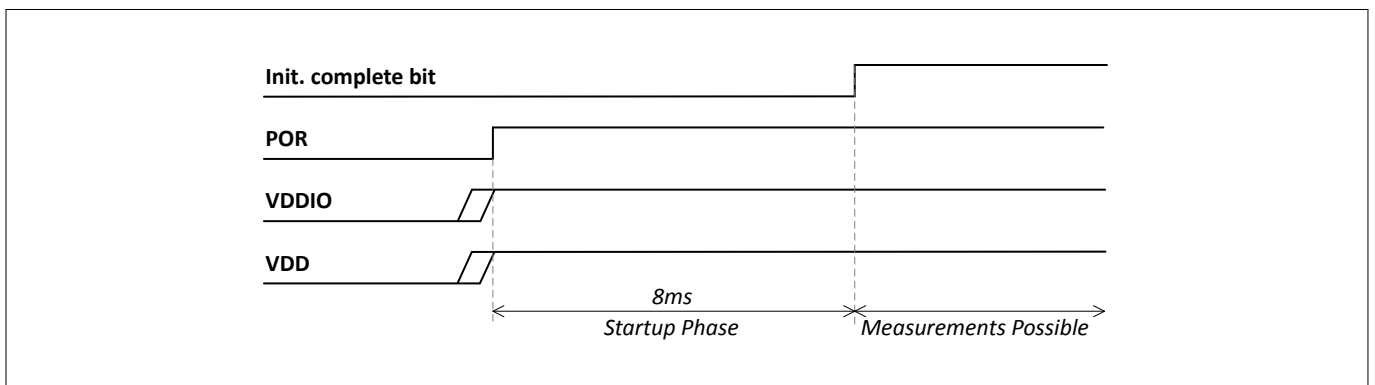

Figure 5 DPS422 start-up sequence.

4.7 Sensor interface

The DPS422 can be accessed as a slave device through mode '11' SPI 3-wire, SPI 4-wire, or I²C serial interface.

- I²C interface
 - The sensor's default interface.
 - The sensor's address is 0x77 (default) or 0x76 (if the SDO pin is pulled-down to GND).
- SPI interface

Functional description

- The sensor will switch to SPI configuration if it detects an active low on the CSB pin. SPI 4-wire is the default SPI interface.
- To enable SPI 3-wire configuration, a bit must be set in the CFG_REG register after start up.

More details about digital interfaces are available in the [Digital interfaces](#) section.

5 Pressure measurement

The DPS422 is a single die MEMS pressure sensor which makes use of a capacitive measurement principle.

The DPS422 sensor element consists of a number of sealed vacuum cells. Each cell consists of a hollow, evacuated cavity with a flexible membrane sealing the top. The top membrane and the bottom of the cell are electrodes, which form a capacitor. Due to the pressure difference between the interior of the cell and the ambient environment, the top membrane is deflected towards the bottom of the cell.

The vacuum cells are combined in a parallel measurement configuration, to increase the sensitivity and noise performance of the DPS422.

Increasing ambient pressure causes greater deflection towards the bottom of the cell and hence an increase in the capacitance between the membrane and the bottom of the cell. Decreasing ambient pressure reduces the deflection of the membrane and reduces the capacitance between the membrane and the bottom of the cell.

Pressure measurement is carried out by measuring the capacitance between the top and bottom of the cells and applying a calculation to the capacitance result to determine the pressure in Pa. It is also required to include a temperature correction in this calculation to eliminate temperature drift from the output.

5.1 Pressure measurement results

After starting the measurements, the latest pressure and temperature raw data will be available as 24-bit 2's complement numbers in their respective result registers if the FIFO is disabled: PSR_B2 to PSR_B0, and TMP_B2 to TMP_B0.

If the FIFO is enabled, all measurement results will be stored in registers PSR_B2 to PSR_B0. In this case, the register value will update to the next result stored in the FIFO after each read. The least significant bit of PSR_B0 will read "1" if the measurement is a pressure reading, or "0" if the measurement is a temperature reading. When all of the FIFO values have been read, the result register will be set to 0x800000.

When the FIFO is disabled, reading the result register will not affect the register value, it will only be updated when a new measurement is completed.

All measurement data can be read in a single command using auto-increment read.

5.1.1 Calculating pressure reading

To calculate the DPS422 pressure reading, it is necessary to first read and parse the calibration coefficient registers from addresses 0x26 to 0x39. These values only need to be read and parsed once for each device, they are fused in memory and will not change during operation. The method to generate the Calibration Coefficient values is described in the [Calibration coefficients](#) section of this document.

The pressure values stored in the result registers must be scaled according to the oversampling rate. The numbers in the registers must be divided by kP before they are used in the pressure reading calculation formula. The kP values for each oversampling option can be found in [Oversampling rate: kP](#).

$$\text{Pre}_{\text{SCALED}} = \text{Pre}_{\text{RAW}} / \text{kP}$$

$$\text{Temp}_X = \text{Temp}_{\text{RAW}} / 1048576$$

$$\text{Temp}_{\text{SCALED}} = (8.5 \times \text{Temp}_X) / (1 + 8.8 \times \text{Temp}_X)$$

Where:

- Pre_{RAW} is the 24 bit, 2's complement number read from the pressure output registers or FIFO
- Temp_{RAW} is the 24 bit, 2's complement number read from the temperature output registers or FIFO

Equation 1 Deriving the scaled pressure and temperature values

Pressure measurement

Once the calibration coefficients have been read, and pressure and temperature register values have been read and scaled, the pressure reading can be calculated using the following formula:

$$\text{Pres}_{\text{CALIBRATED}} = C00 + [C10 \times \text{Pres}_{\text{SCALED}}] + [C01 \times \text{Temp}_{\text{SCALED}}] + [C20 \times \text{Pres}_{\text{SCALED}}^2] + [C02 \times \text{Temp}_{\text{SCALED}}^2] + [C30 \times \text{Pres}_{\text{SCALED}}^3] + [C11 \times \text{Pres}_{\text{SCALED}} \times \text{Temp}_{\text{SCALED}}] + [C12 \times \text{Pres}_{\text{SCALED}} \times \text{Temp}_{\text{SCALED}}^2] + [C21 \times \text{Pres}_{\text{SCALED}}^2 \times \text{Temp}_{\text{SCALED}}]$$

Where:

- C00, C10, C01, C20, C02, C30, C11, C12 and C21 are the calibration coefficients read from registers 0x26 to 0x39.

Equation 2 DPS422 pressure output calculation

6 Temperature measurement

The DPS422 temperature measurement uses a silicon bandgap temperature sensor, measuring the base-emitter voltage (V_{BE}) of two BJT transistors, biased at different currents (I_{C1} and I_{C2}). This measurement is used at a system level in the pressure output calculation to correct any temperature related measurement drift.

The temperature of the transistors can be accurately determined by measuring the difference in voltage between both and applying the formula: $\Delta V_{BE} = ((K \cdot T) / q) \cdot (\ln(I_{C1} / I_{C2}))$

Where T is the temperature in Kelvin, K is Boltzmann's constant and q is the charge of a single electron.

The measurement rate and precision (oversampling) can be modified by writing to the TEMP_CFG register, as described in the [Measurement precision and rate](#) section.

Note: For ambient temperature sensing, full system modeling should be carried out across temperature. This will account for internal heating effects of the system when calculating the ambient temperature value.

6.1 One time calculation of A' and B' coefficients

In order to calculate temperature output values in °C, it is first necessary to calculate two coefficients, **A'** and **B'**. These coefficients are calculated from values stored in the DPS422 calibration coefficients registers, and do not change. These two coefficients can be calculated once on device start up and then stored in memory to be used in all future high accuracy temperature measurements.

The steps required to calculate A' and B' are below, calculation constants can be found in [Table 10](#).

1. Read T_Vbe, T_dVbe and T_gain:

These parameters are read directly from the calibration coefficient registers 0x20 to 0x22. These three values are in 2's complement.

2. Calculate V_{BE}, ΔV_{BE} and A_{ADC}:

These values are calculated directly from the calibration coefficient values:

- $V_{BE} = T_Vbe \times 1.05031E-4 + 0.463232422$
- $\Delta V_{BE} = T_dVbe \times 1.25885E-5 + 0.04027621$
- $A_{ADC} = T_gain \times 8.4375E-5 + 0.675$

3. Calculate V_{BE_CAL} and ΔV_{BE_CAL}:

- $V_{BE_CAL} = V_{BE} / A_{ADC}$
- $\Delta V_{BE_CAL} = \Delta V_{BE} / A_{ADC}$

4. Calculate calibration Temperature T_{CALIB}:

- $T_{CALIB} = A_0 \times \Delta V_{BE_CAL} - 273.15$

5. Calculate V_{BE_CAL}(T_{REF}), the V_{BE} value at reference temperature T_{REF}:

- $V_{BE_CAL}(T_{REF}) = V_{BE_CAL} - (T_{CALIB} - T_{REF}) \times (T_{C_VBE})$

6. Calculate PTAT correction coefficient:

- $k_{PTAT} = [V_{BE_TARGET}(T_{REF}) - V_{BE_CAL}(T_{REF})] \times k_{PTAT_CORNER} + k_{PTAT_CURVATURE}$

7. Calculate A' and B' coefficients:

- $A' = A_0 \times (V_{BE_CAL} + \alpha \times \Delta V_{BE_CAL}) \times (1 + k_{PTAT})$
- $B' = -273.15 \times (1 + k_{PTAT}) - k_{PTAT} \times T_{CALIB}$

6.2 Calculating temperature output using A' and B'

Once the A' and B' coefficients have been calculated once, they can be stored in the host system and used for all future high accuracy temperature calculations for that DPS422 unit.

The calculation of high accuracy temperature readings using A' and B' is a four step process, shown below.

1. Read out temperature result T_{RAW} from registers TMP_B2 to TMP_B0 or FIFO, if enabled.
2. Scale the temperature measurement:
 - $T_{CAL} = T_{RAW} / 1048576$
3. Calculate μ coefficient:
 - $\mu = T_{CAL} / (1 + \alpha \times T_{CAL})$
4. Calculate T_{OUT} :
 - $T_{OUT} = (A' \times \mu) + B'$

6.3 A' and B' calculation constants

The following table lists all of the coefficients required to calculate the A' and B' coefficients, as described in the [One time calculation of A' and B' coefficients](#) section.

Table 10 A' and B' calculation constants

Name	Unit	Value
T_{REF}	°C	27
$V_{BE_TARGET}(T_{REF})$	V	0.687027
α	-	9.45
T_{C_VBE}	V	-1.735E-3
k_{PTAT_CORNER}	-	-0.8
$k_{PTAT_CURVATURE}$	-	0.039
A_0	K	5030

7 Applications

7.1 Measurement settings and use case examples

The DPS422 provides versatile pressure measurements for a wide range of applications. The requirements of these applications can be very different, and so the DPS422 can be quickly configured with a couple of register writes to ensure the speed, accuracy and current consumption are in line with the application priorities.

Table 11 Measurement settings and use case examples

Use Case	Performance	Pressure Register Configuration Address: 0x06	Temperature Register Configuration Address: 0x07	FIFO Enabled? Address: 0x09	Other
Weather Station (Low power)	5 Pa precision. 1 pr sec. 3 μ A FIFO disabled	0x01	0x00	Bit 1 = 0	Start background measurements (addr 0x08)
Indoor navigation (Standard precision, background mode)	10 cm precision. 2 pr sec. 35 μ A FIFO enabled	0x14	0x93	Bit 1 = 1	Start background measurements (addr 0x08)
Sports (High precision, high rate, background mode)	5 cm precision 4 pr sec. 175 μ A FIFO enabled	0x26	0xA3	Bit 1 = 1	Start background measurements (addr 0x08)

7.2 Application circuit examples

The example application circuits below demonstrate the connection of the I²C and SPI serial interfaces.

- In I²C mode, the *SDO* pin can be used for interrupt output and/or to set the least significant bit of the device address.
- In 3-wire SPI mode, the *SDO* pin can be used for interrupt output.
- In 4-wire SPI mode, the *SDO* pin can only be used as the serial data output.

The DPS422 analog core supply voltage is internally regulated, guaranteeing robustness to external VDD supply variations within the specified range. The simplest voltage supply solution is to connect VDD and VDDIO to 1.8V supply and add a suitable decoupling capacitor to reduce VDD ripple below 50mVpp.

Applications

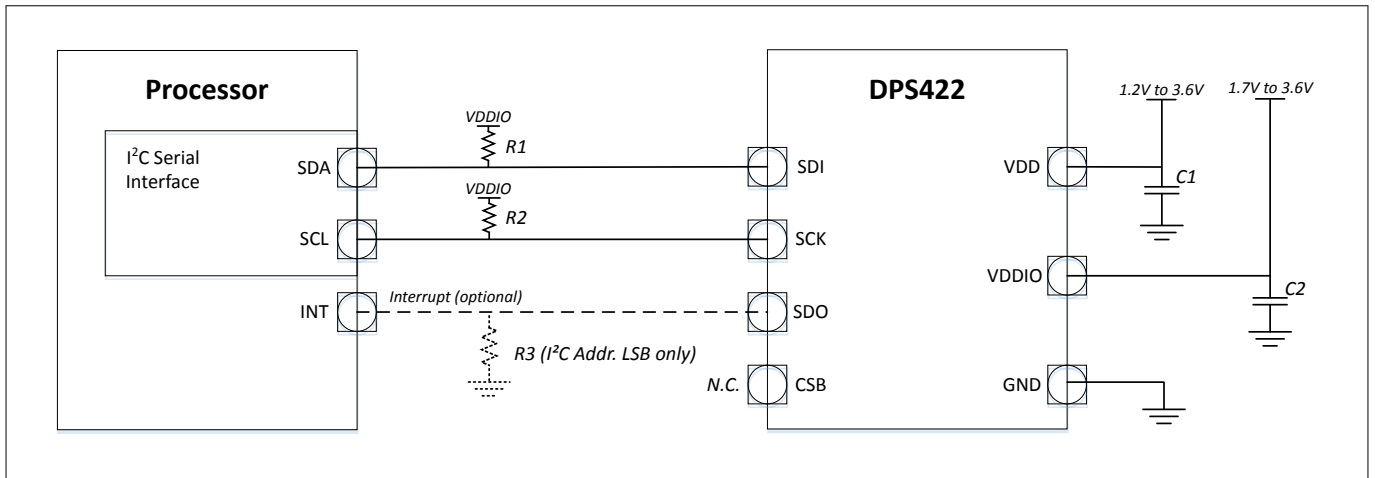

Figure 6 Application circuit example using the I²C serial interface.

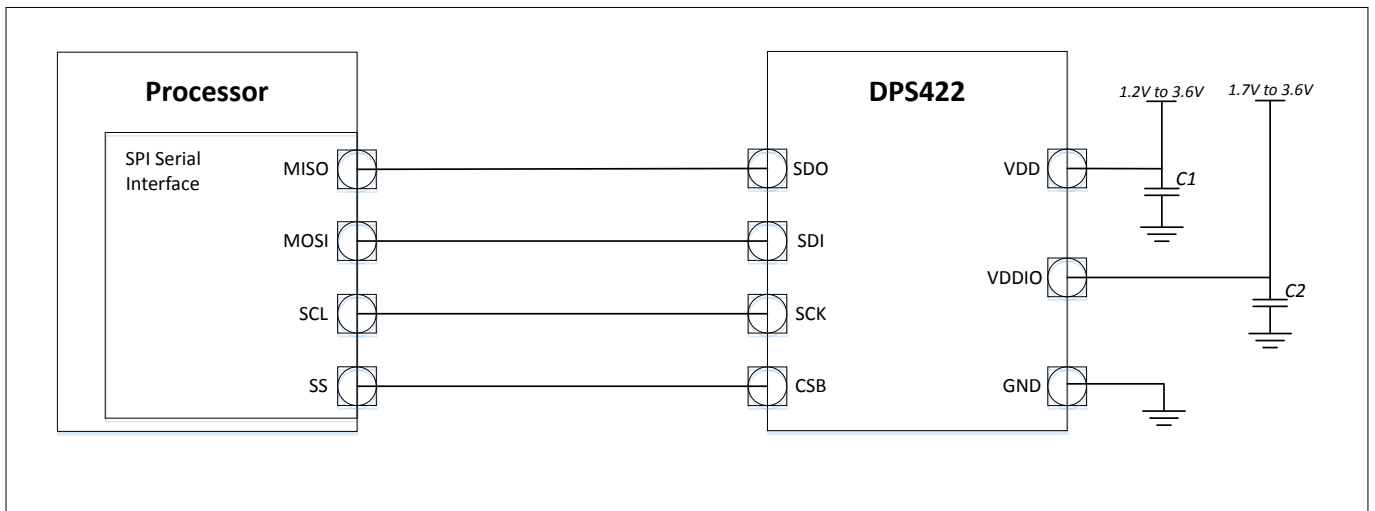

Figure 7 Application circuit example using the SPI 4-wires serial interface

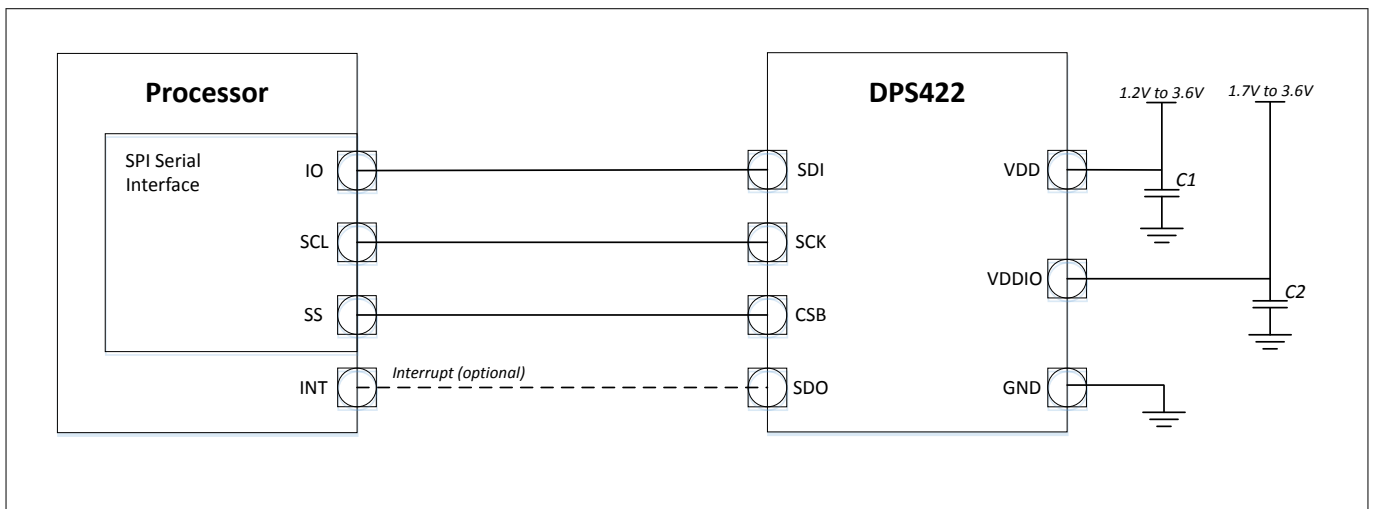

Figure 8 Application circuit example using the SPI 3-wire serial interface

Applications

Table 12 Component values

Component	Symbol	Values			Unit	Note / Test Condition
		Min.	Typ.	Max.		
Pull-up/down Resistor	R ₁ , R ₂			10	kΩ	
	R ₃			100	kΩ	R ₃ is optional and will set the address to 0x76 instead of 0x77.
Supply Blocking Capacitor	C ₁ , C ₂	100	100		nF	The blocking capacitors should be placed as close to the package pins as possible.

8 Digital interfaces

The DPS422 measurement data, calibration coefficients, Product ID and configuration registers can be accessed through both the I²C and SPI serial interfaces.

The SPI interface can be configured to operate in 3-wire or 4-wire mode.

In I²C and SPI 3-wire, an interrupt output can be implemented on the SDO pin.

The SPI interface only supports mode '11' (CPOL=CPHA='1') in 4-wire and 3-wire configuration.

The following commands are supported by the I²C interface:

- Single byte read
- Single byte write
- Multi-byte read, with automatic register increment
- Multi-byte write, with automatic register increment

The following commands are supported by the SPI interface:

- Single byte read
- Single byte write
- Multi-byte read, with automatic register increment

Note: Multi-byte write is not supported by the SPI interface.

The communication interface is selected using the CSB pin:

- If CSB is connected to V_{DDIO}, the I²C interface is active.
- If CSB is connected to ground, the SPI interface is active.

Once CSB has been pulled down, the I²C interface is disabled until the next power-on-reset.

If CSB is high, the I²C interface is selected by addressing the DPS422 over the I²C bus. After this, the I²C interface is locked, and pulling down CSB will not activate the SPI interface. The SPI interface can only be selected by pulling CSB low after the next power-on-reset, before the DPS422 is addressed over I²C.

8.1 I²C interface

The I²C slave interface is compatible with Philips I²C Specification version 2.1. The I²C interface supports standard, fast and high speed mode.

The sensor's address is 0x77 if the SDO pin is left floating or pulled-up to V_{DDIO}, or 0x76 if the SDO pin is pulled-down to GND. The I²C interface uses the pins described in the [Pin configuration](#) section.

The basic timing is shown in the diagram below:

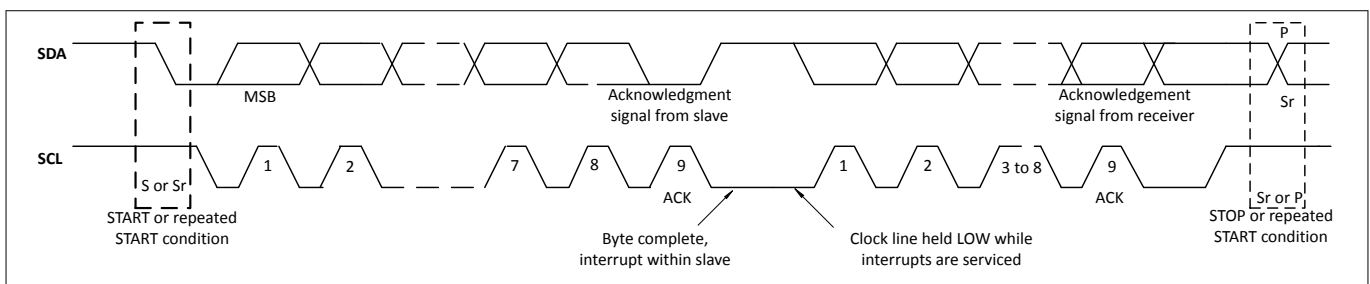

Figure 9 I²C timing diagram

In one access, without a stop command, incremental read (address is auto increment) and auto-incremental write are supported. The read and write access is shown below:

Digital interfaces

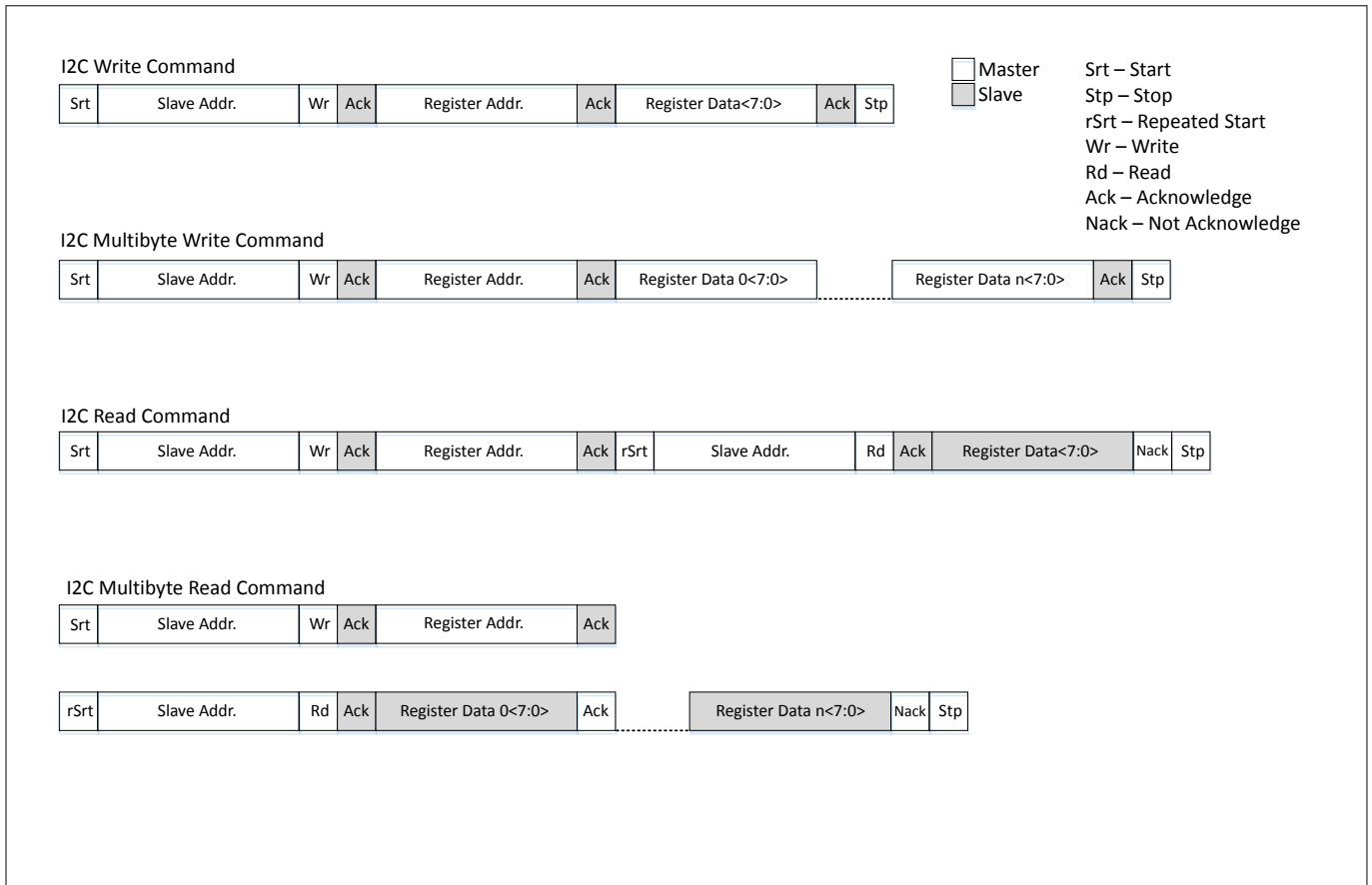

Figure 10 I2C write and read commands

8.2 SPI interface

The SPI interface is compatible with SPI mode '11' (CPOL = CPHA = '1'). The SPI interface has two modes: 4-wire and 3-wire.

The protocol for 3-wire and 4-wire SPI is similar. The 3-wire SPI protocol uses a single shared data line, the 4-wire SPI protocol uses separate Serial Data Out (SDO) and Serial Data In (SDI) data lines. The naming of these data lines refers to the direction of data relative to the slave device.

3-wire SPI mode is selected by setting bit[0] in the CFG_REG register to '1'.

The SPI interface uses the pins described in the [Pin configuration](#) section. Refer to [Application circuit examples](#) for connection instructions. The SPI protocol is shown in the diagram below:

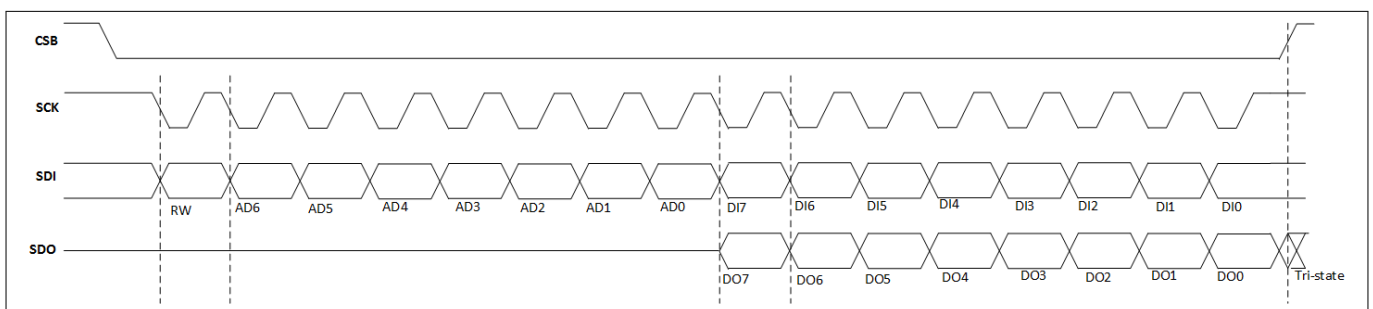

Figure 11 SPI protocol, 4-wire without interrupt

An SPI write is carried out by setting CSB low and sending a control byte followed by register data. The control byte consist of the SPI register address (full register address without bit 7) and the write command (bit 7 = RW = '0'). Setting CSB high ends the transaction. The SPI write protocol is described in the diagram below.

Digital interfaces

An SPI read is initiated by setting CSB low and sending a single control byte. The control byte consist of the SPI register address (full register address without bit 7) and the read command (bit 7 = RW = '1'). After writing the control byte, data is sent out of the SDO pin (SDI in 3-wire mode); the register address is automatically incremented. Setting CSB high ends the SPI read transaction. The SPI read protocol is shown in the diagram below:

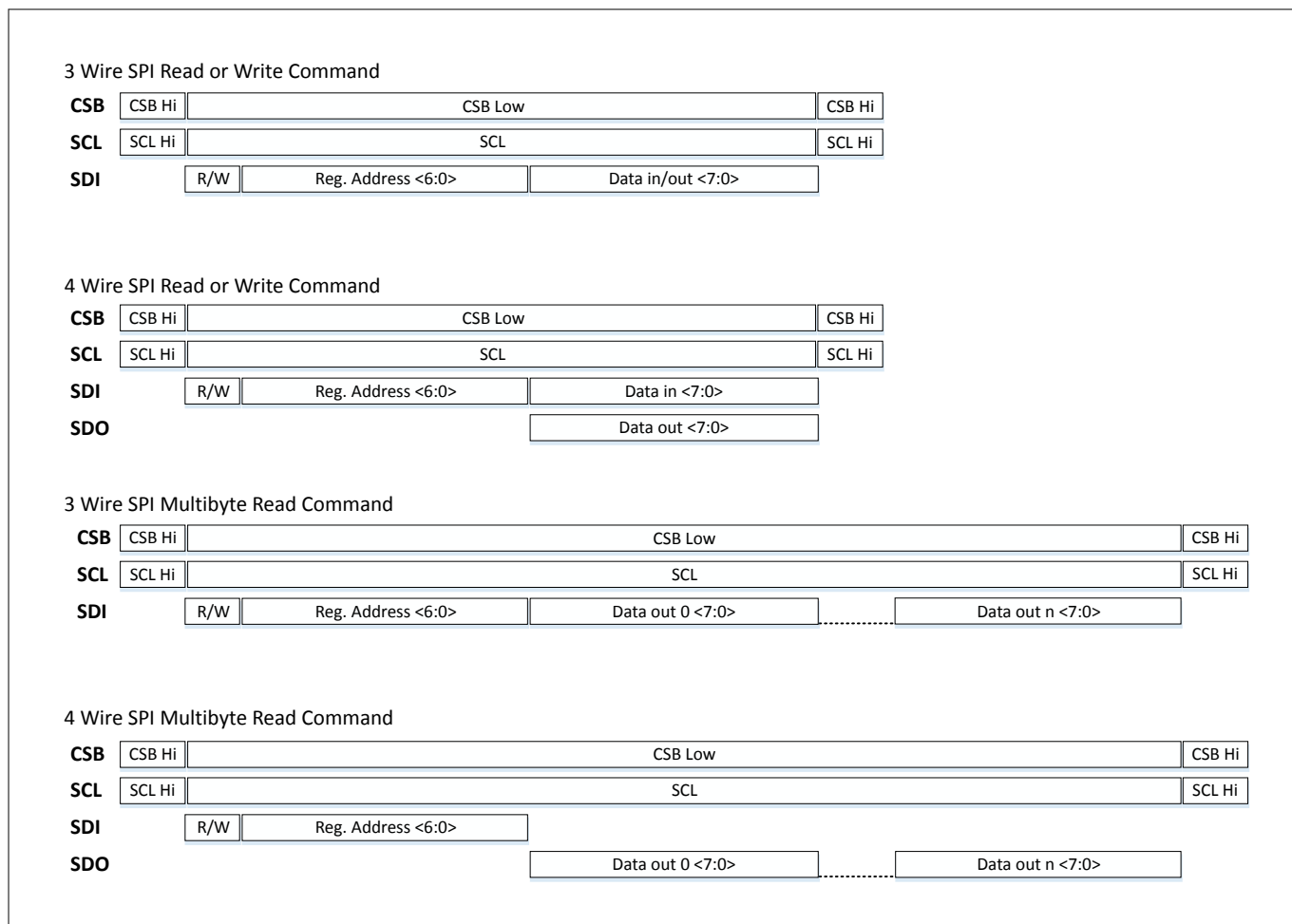

Figure 12 SPI write, read protocol diagrams

8.3 Interface parameter specification

8.3.1 General interface parameters

The general interface parameters are given in the table below:

Table 13 Interface parameters

Parameter	Symbol	Values			Unit	Note or Test Condition
		Min.	Typ.	Max.		
Input voltage for low logic level at input pins	Vlow_in			0.3 * V _{DDIO}	V	V _{DDIO} =1.2V to 3.6V
Input voltage for high logic level at input pins	Vhigh_in	0.7 * V _{DDIO}			V	V _{DDIO} =1.2V to 3.6V

Table 13 Interface parameters (continued)

Parameter	Symbol	Values			Unit	Note or Test Condition
		Min.	Typ.	Max.		
Output - low level for I2C	Vlow_SDI			0.1 * V _{DDIO}	V	V _{DDIO} =1.8V, i _{ol} =2mA
Output voltage for low level at pin SDI for I2C	Vlow_SDI_1.2			0.2* V _{DDIO}	V	V _{DDIO} =1.20V, i _{ol} =1.3mA
Output voltage for high level at pins SDO, SDI	Vhigh_out	0.8 * V _{DDIO}			V	V _{DDIO} =1.8V, i _{ol} =1mA (SDO, SDI)
Output voltage for high level at pins SDO, SDI	Vhigh_out_1.2	0.6 * V _{DDIO}			V	V _{DDIO} =1.2V, i _{ol} =1mA (SDO, SDI)
Pull-up resistor	Rpull	60	120	180	kohm	Internal pull-up resistance to V _{DDIO}
I ² C bus load capacitor	Cb			400	pF	On SDI and SCK

8.3.2 I2C timing parameters

The I²C timing is shown in the diagram below and corresponding values are given in the table below. The naming refers to I²C Specification version 2.1, the abbreviations used "S&F mode" = standard and fast mode, "HS mode" = high speed mode, C_b = bus capacitance on SDA line.

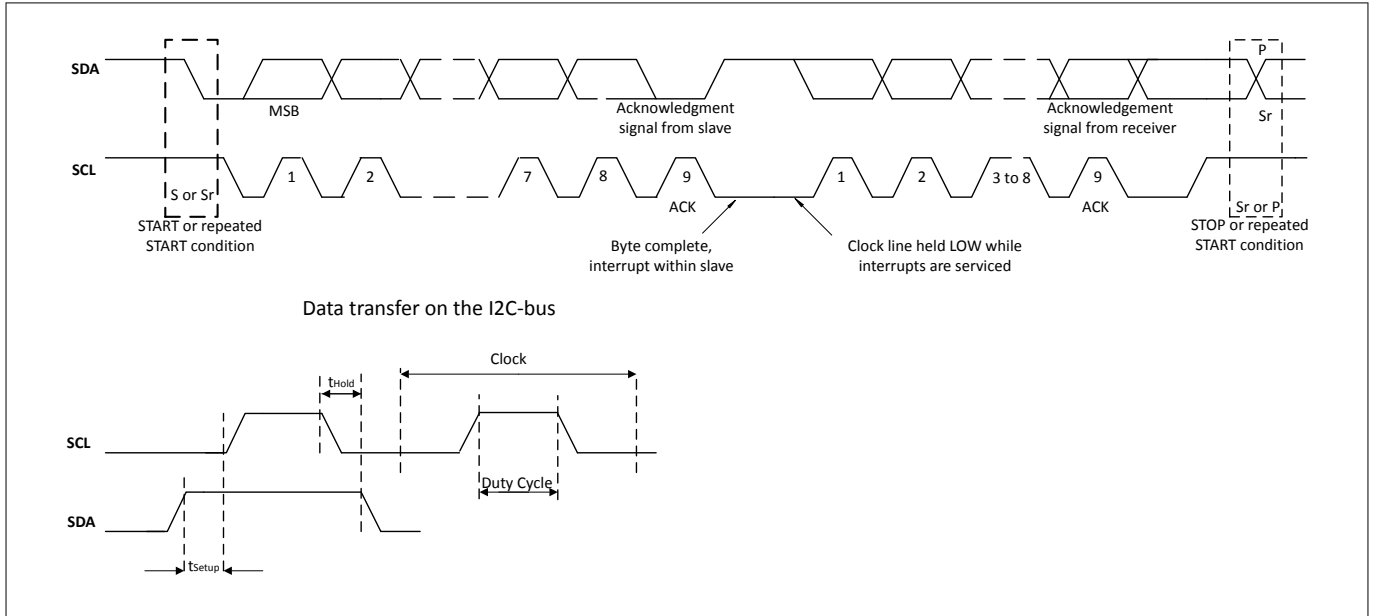

Figure 13 I²C timing diagram

Table 14 I2C timings

Parameter	Symbol	Values			Unit	Note or Test Condition
		Min.	Typ.	Max.		
Data setup time on SDI pin	t _{Setup}	20			ns	S&F mode
		5			ns	HS mode
Data hold time on SDI pin	t _{Hold}	0			ns	S&F&HSmode,
Duty Cycle	DC			70	%	S&F mode,
				55	%	HS mode,

8.3.3 SPI timing parameters

The SPI timing diagram is shown in the figure below and the corresponding values are given in the table below. All timings apply both to 4-wire and 3-wire SPI.

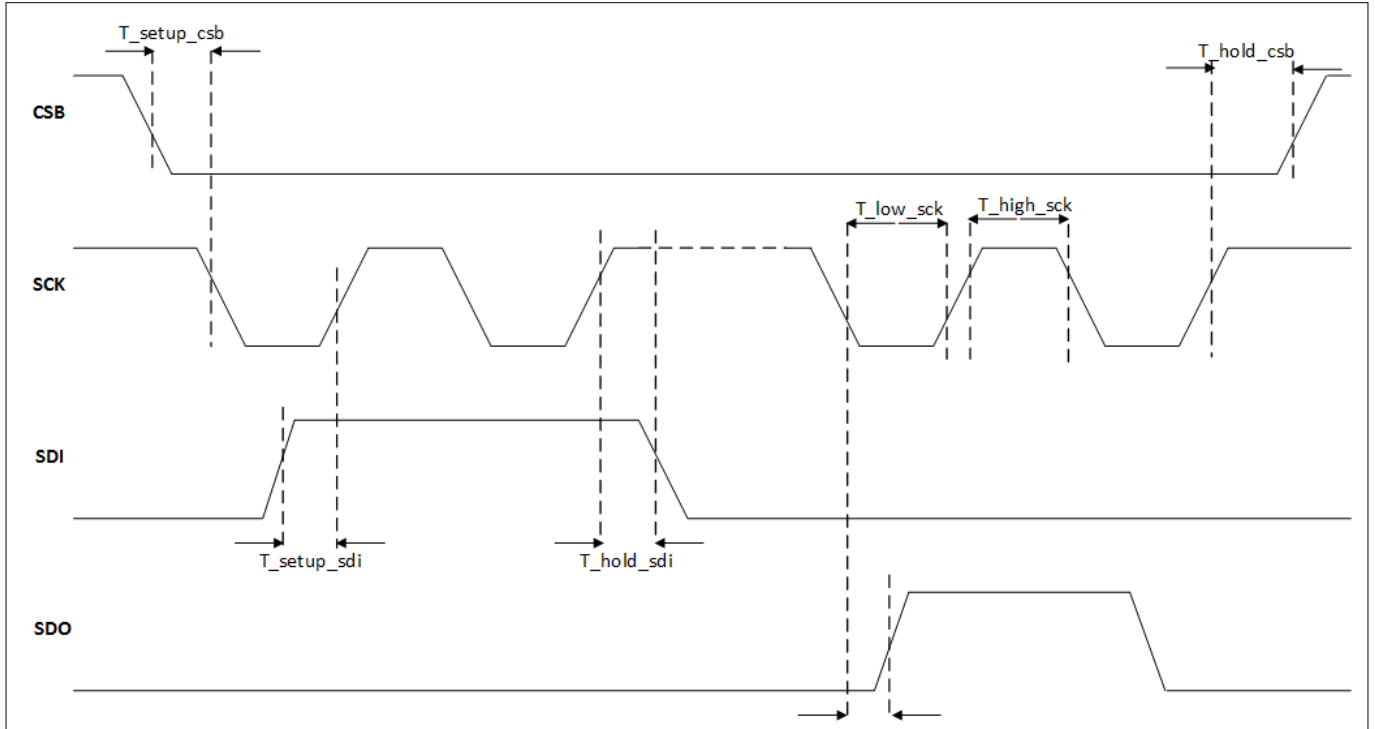

Figure 14 SPI timing diagram

Table 15 SPI timings

Parameter	Symbol	Values			Unit	Note or Test Condition
		Min.	Typ.	Max.		
Duty Cycle (Thigh%)	SPI_DC	30			%	V _{DDIO} = 1.2V
		20			%	V _{DDIO} = 1.8V/3.6V
SDI setup time	T _{setup_sdi}	2			ns	
SDI hold time	T _{hold_sdi}	2			ns	
Clock	SPI_CLK			10	MHz	
CSB setup time	T _{setup_csb}	15			ns	
CSB hold time		15			ns	

9 Register map

The DPS422 user registers are listed and described below. The calibration coefficient registers can be found in the [Calibration coefficients](#) section.

Table 16 DPS422 Register Map

Register Name	Addr.	Bit 7	Bit 6	Bit 5	Bit 4	Bit 3	Bit 2	Bit 1	Bit 0	Reset Value
PSR_B2	0x00	Pressure measurement MSB <23:16>								0x80
PSR_B1	0x01	Pressure measurement LSB <15:8>								0x00
PSR_B0	0x02	Pressure measurement XLSB <7:0>								0x00
TMP_B2	0x03	Temperature measurement MSB <23:16>								0x80
TMP_B1	0x04	Temperature measurement LSB <15:8>								0x00
TMP_B0	0x05	Temperature measurement XLSB <7:0>								0x00
PSR_CFG	0x06	-	Pressure measurement rate [2:0]			-	Pressure measurement resolution [3:0]			0x00
TEMP_CFG	0x07	Must be set to 1	Temperature measurement rate [2:0]			-	Temperature measurement resolution [3:0]			0x80
MEAS_CFG	0x08	Init. complete	Cont. mode flag	Temp. data ready	Press. data ready	-	Measurement control [2:0]			0x00
CFG_REG	0x09	Interrupt select [3:0]				Interrupt polarity	FIFO Stop on full	FIFO enable	SPI mode	0x00
INT_STS	0x0A	-	-	-	-	-	FIFO interrupt Full / WM	Temp. interrupt	Press. interrupt	0x00
WM_CFG	0x0B	-	-	-	Watermark level[4:0]				0x1F	
FIFO_STS	0x0C	FIFO fill level[5:0]					FIFO Full / WM	FIFO empty	0x00	
RESET	0x0D	FIFO flush	-	-	-	Soft reset[3:0]			0x00	
PROD_ID	0x1D	Revision ID[3:0]				Product ID[3:0]				0x1A

Attention: To ensure correct functionality, registers not listed in this register map must not be accessed.

10 Register descriptions

10.1 PSR_B2

Register containing most significant byte of the pressure measurement result.

Address: 0x00

Reset Value: 0x80

Table 17 PSR_B2 register

Bit 7	Bit 6	Bit 5	Bit 4	Bit 3	Bit 2	Bit 1	Bit 0
PSR23	PSR22	PSR21	PSR20	PSR19	PSR18	PSR17	PSR16

Table 18 PSR_B2 bit fields

Bit Name	Bits	Type	Description
Pressure measurement MSB <23:16>	<7:0>	R	Pressure measurement result bits 23 to 16.

10.2 PSR_B1

Register containing middle byte of the pressure measurement result.

Address: 0x01

Reset Value: 0x00

Table 19 PSR_B1 register

Bit 7	Bit 6	Bit 5	Bit 4	Bit 3	Bit 2	Bit 1	Bit 0
PSR15	PSR14	PSR13	PSR12	PSR11	PSR10	PSR9	PSR8

Table 20 PSR_B1 bit fields

Bit Name	Bits	Type	Description
Pressure measurement LSB <15:8>	<7:0>	R	Pressure measurement result bits 15 to 8.

10.3 PSR_B0

Register containing least significant byte of the pressure measurement result.

Address: 0x02

Reset Value: 0x00

Table 21 PSR_B0 register

Bit 7	Bit 6	Bit 5	Bit 4	Bit 3	Bit 2	Bit 1	Bit 0
PSR7	PSR6	PSR5	PSR4	PSR3	PSR2	PSR1	PSR0

Register descriptions

Table 22 PSR_B0 bit fields

Bit Name	Bits	Type	Description
Pressure measurement XLSB <7:0>	<7:0>	R	Pressure measurement result bits 7 to 0.

10.4 TMP_B2

Register containing most significant byte of the temperature measurement result.

Address: 0x03

Reset Value: 0x80

Table 23 TMP_B2 register

Bit 7	Bit 6	Bit 5	Bit 4	Bit 3	Bit 2	Bit 1	Bit 0
TMP23	TMP22	TMP21	TMP20	TMP19	TMP18	TMP17	TMP16

Table 24 TMP_B2 bit fields

Bit Name	Bits	Type	Description
Temperature measurement MSB <23:16>	<7:0>	R	Temperature measurement result bits 23 to 16.

10.5 TMP_B1

Register containing middle byte of the temperature measurement result.

Address: 0x04

Reset Value: 0x00

Table 25 TMP_B1 register

Bit 7	Bit 6	Bit 5	Bit 4	Bit 3	Bit 2	Bit 1	Bit 0
TMP15	TMP14	TMP13	TMP12	TMP11	TMP10	TMP9	TMP8

Table 26 TMP_B1 bit fields

Bit Name	Bits	Type	Description
Temperature measurement LSB <15:8>	<7:0>	R	Temperature measurement result bits 15 to 8.

10.6 TMP_B0

Register containing least significant byte of the temperature measurement result.

Address: 0x05

Reset Value: 0x00

Register descriptions

Table 27 **TMP_B0 register**

Bit 7	Bit 6	Bit 5	Bit 4	Bit 3	Bit 2	Bit 1	Bit 0
TMP7	TMP6	TMP5	TMP4	TMP3	TMP2	TMP1	TMP0

Table 28 **TMP_B0 bit fields**

Bit Name	Bits	Type	Description
Temperature measurement XLSB <7:0>	<7:0>	R	Temperature measurement result bits 7 to 0.

Register descriptions

10.7 PSR_CFG

Configuration register for pressure measurement. Pressure or stress measurements can be enabled. Pressure measurement rate and resolution can be modified.

Address: 0x06

Reset Value: 0x00

Table 29 PSR_CFG register

Bit 7	Bit 6	Bit 5	Bit 4	Bit 3	Bit 2	Bit 1	Bit 0
-	Pressure measurement rate[2:0]			-	Pressure measurement resolution[2:0]		

Table 30 PSR_CFG bit fields

Bit Name	Bits	Type	Description
Pressure measurement rate[2:0]	<6:4>	RW	Pressure measurement rate: <ul style="list-style-type: none"> • 000 - 1 sample/sec • 001 - 2 samples/sec • 010 - 4 samples/sec • 011 - 8 samples/sec • 100 - 16 samples/sec • 101 - 32 samples/sec • 110 - 64 samples/sec • 111 - 128 samples/sec
Pressure measurement resolution[2:0]	<2:0>	RW	Pressure measurement resolution: <ul style="list-style-type: none"> • 000 - 256 samples - 1x decimation • 001 - 512 samples - 2x decimation • 010 - 1024 samples - 4x decimation • 011 - 2048 samples - 8x decimation • 100 - 4096 samples - 16x decimation • 101 - 8192 samples - 32x decimation • 110 - 16384 samples - 64x decimation • 111 - 32768 samples - 128x decimation

Register descriptions

Table 31 Precision (Pa_{RMS}) and pressure measurement time (ms) versus oversampling rate

Oversampling (PSR_CFG[3:0])	1x (0000)	2x (0001)	4x (0010)	8x (0011)	16x (0100)	32x (0101)	64x (0110)	128x (0111)
Measurement time (ms)	3.6	5.2	8.4	14.8	27.6	53.2	104.4	206.8
Precision (Pa _{RMS})	5		2.5		1.2	0.9	0.5	

Table 32 Estimated current consumption (μA)

Oversampling (PSR_CFG[3:0])	1x (0000)	2x (0001)	4x (0010)	8x (0011)	16x (0100)	32x (0101)	64x (0110)	128x (0111)
Measurements pr sec. (PM_RATE([2:0])								
1 (000)	2.1	2.7	3.8	6.1	11	20	38	75
2 (001)								
4 (010)								
8 (011)	Note: The current consumption can be calculated as the Measurement Rate * Current Consumption of 1 measurement per. sec.							n.a.
16 (100)							n.a.	n.a.
32 (101)						n.a.	n.a.	n.a.
64 (110)					n.a.	n.a.	n.a.	n.a.
128 (111)			n.a.	n.a.	n.a.	n.a.	n.a.	n.a.

Note: The table shows the possible combinations of Pressure Measurement Rate and oversampling when no temperature measurements are performed. When temperature measurements are performed the possible combinations are limited to $Rate_{\text{temperature}} \times Measurement\ Time_{\text{temperature}} + Rate_{\text{pressure}} \times Measurement\ Time_{\text{pressure}} < 1\ \text{second}$.

Temperature measurement time versus temperature oversampling rate is similar to pressure measurement time versus pressure oversampling rate.

Register descriptions

10.8 TEMP_CFG

Configuration register for temperature measurements. Temperature measurement rate and resolution can be modified.

Address: 0x07

Reset Value: 0x00

Table 33 TEMP_CFG register

Bit 7	Bit 6	Bit 5	Bit 4	Bit 3	Bit 2	Bit 1	Bit 0
Must be set to 1	Temperature measurement rate [2:0]		-	Temperature measurement resolution [2:0]			

Table 34 TEMP_CFG bit fields

Bit Name	Bits	Type	Description
Must be set to 1	<7>	RW	<i>Warning:</i> This bit must be set to '1' to configure the temperature measurement correctly. If this bit is not set, the temperature and pressure measurements will not function correctly.
Temperature measurement rate [2:0]	<6:4>	RW	Temperature measurement rate: <ul style="list-style-type: none"> 000 - 1 sample/sec 001 - 2 samples/sec 010 - 4 samples/sec 011 - 8 samples/sec 100 - 16 samples/sec 101 - 32 samples/sec 110 - 64 samples/sec
Temperature measurement resolution [2:0]	<2:0>	RW	Temperature measurement resolution: <ul style="list-style-type: none"> 000 - 256 samples - 1x decimation 001 - 512 samples - 2x decimation 010 - 1024 samples - 4x decimation 011 - 2048 samples - 8x decimation 100 - 4096 samples - 16x decimation 101 - 8192 samples - 32x decimation 110 - 16384 samples - 64x decimation 111 - 32768 samples - 128x decimation

Table 35 Temperature measurement time (ms) versus oversampling rate

Oversampling (TEMP_CFG[2:0])	Single (000)	2 times (001)	4 times (010)	8 times (011)	16 times (100)	32 times (101)	64 times (110)
Measurement time (ms)	5.2	8.4	14.8	27.6	53.2	104.4	206.8

Register descriptions

10.9 MEAS_CFG

Configuration register for general measurement settings.

Address: 0x08

Reset Value: 0x00

Table 36 MEAS_CFG register

Bit 7	Bit 6	Bit 5	Bit 4	Bit 3	Bit 2	Bit 1	Bit 0
Init. complete	Cont. mode flag	Temp. data ready	Press. data ready	-	Measurement control [2:0]		

Table 37 MEAS_CFG bit fields

Bit Name	Bits	Type	Description
Init. complete	<7>	R	Status bit set when initialisation procedure is complete.
Cont. mode flag	<6>	R	Status bit set when DPS422 is in continuous measurement mode.
Temp. data ready	<5>	R	Status bit set when new temperature measurement data is available. Cleared when register 0x05 is read.
Press. data ready	<4>	R	Status bit set when new pressure measurement data is available. Cleared when register 0x02 is read.
Measurement control [2:0]	<2:0>	RW	Configuration register controlling measurement mode: <ul style="list-style-type: none"> • 000 - Idle / Stop Background • 001 - Pressure Measurement • 010 - Temperature Measurement • 011 - Pressure and Temperature Measurement one shot • 100 - Idle / Stop Background • 101 - Continuous Pressure Measurement • 110 - Continuous Temperature Measurement • 111 - Continuous Pressure and Temperature Measurement

Register descriptions

10.10 CFG_REG

Interrupt, SPI mode and FIFO configuration register.

Address: 0x09

Reset Value: 0x00

Table 38 CFG_REG register

Bit 7	Bit 6	Bit 5	Bit 4	Bit 3	Bit 2	Bit 1	Bit 0
Interrupt select[3:0]				Interrupt polarity	FIFO Stop on full	FIFO enable	SPI mode

Table 39 CFG_REG bit fields

Bit Name	Bits	Type	Description
Interrupt select[3:0]	<7:4>	RW	Select interrupt source: <ul style="list-style-type: none"> 0000 - no interrupt enabled 0001 - Pressure Interrupt enabled 0010 - Temperature Interrupt enabled 0011 - Pressure & Temperature Interrupt enabled 0100- FIFO Watermark Interrupt enabled 1000- FIFO FULL Interrupt enabled All other settings are invalid. Interrupt pin(SDO pin) is cleared when the Interrupt Status Register (0x0A) is read.
Interrupt polarity	<3>	RW	Interrupt active polarity: <ul style="list-style-type: none"> 0 - Active low 1 - Active high <i>Note: Interrupt can only be output when the DPS422 is in I²C or 3-wire SPI modes.</i>
FIFO Stop on full	<2>	RW	Configures FIFO behaviour when full: <ul style="list-style-type: none"> 0 - FIFO in streaming mode. When full, oldest data is overwritten as new data is available. 1 - FIFO in stop on full mode. When full, old data is retained, new data is not stored.
FIFO enable	<1>	RW	Enables pressure and temperature result FIFO: <ul style="list-style-type: none"> 0 - FIFO is disabled. Old results are not stored. Pressure and temperature results stored in respective results registers. 1 - FIFO is enabled. Results are read from result registers 0x00 - 0x02. Up to 32 results can be stored.
SPI mode	<0>	RW	Configures the SPI protocol used: <ul style="list-style-type: none"> 0 - 4-wire SPI interface. 1 - 3-wire SPI interface

Register descriptions

10.11 INT STS

Register reflecting the current status of the DPS422 interrupt sources. All bits are clear on read.

Address: 0x0A

Reset Value: 0x00

Table 40 INT STS register

Bit 7	Bit 6	Bit 5	Bit 4	Bit 3	Bit 2	Bit 1	Bit 0
-	-	-	-	-	FIFO interrupt Full / WM	Temp. interrupt	Press. interrupt

Note: The interrupt pin, and this register itself are cleared when this register is read.

Table 41 INT STS bit fields

Bit Name	Bits	Type	Description
FIFO interrupt Full / WM	<3>	R	This bit is set when FIFO is full or when FIFO reaches watermark level. Source depends on setting inCFG_REG register. <i>Note:</i> This bit should not be polled faster than once per 375 μ s.
Temp. interrupt	<2>	R	This bit is set when new temperature data is available.
Press. interrupt	<1>	R	This bit is set when new pressure data is available.

Register descriptions

10.12 WM_CFG

FIFO watermark level configuration register.

Address: 0x0B

Reset Value: 0x1F

Table 42 WM_CFG register

Bit 7	Bit 6	Bit 5	Bit 4	Bit 3	Bit 2	Bit 1	Bit 0
-	-	-	Watermark level[4:0]				

Table 43 WM_CFG bit fields

Bit Name	Bits	Type	Description
Watermark level[4:0]	<4:0>	RW	Configures number of measurement results which must be in the FIFO to trigger the FIFO watermark interrupt. <ul style="list-style-type: none"> 0x00 - Interrupt generated when FIFO contains 1 unread measurement result. 0x1F - Interrupt generated when FIFO contains 32 unread measurement results.

Register descriptions

10.13 FIFO_STS

FIFO status register, reflecting FIFO fill and watermark status.

Address: 0x0C

Reset Value: 0x00

Table 44 FIFO_STS register

Bit 7	Bit 6	Bit 5	Bit 4	Bit 3	Bit 2	Bit 1	Bit 0
FIFO fill level[5:0]						FIFO Full / WM	FIFO empty

Table 45 FIFO_STS bit fields

Bit Name	Bits	Type	Description
FIFO fill level[5:0]	<7:2>	R	This bit field contains the number of pressure and/or temperature measurements currently stored in the measurement results FIFO.
FIFO Full / WM	<1>	R	This bit is set when FIFO is full or when FIFO reaches watermark level. Source depends on setting in WM_CFG register. <i>Note: This bit is updated every 250 μs</i>
FIFO empty	<0>	R	This bit is set when the FIFO is empty. <ul style="list-style-type: none"> 0 - FIFO currently contains data 1 - FIFO does not currently contain data <i>Note: This bit is updated every 250 μs</i>

Register descriptions

10.14 RESET

Reset register allows soft reset of the DPS422, and flushing of the measurement results FIFO.

Address: 0x0D

Reset Value: 0x00

Table 46 RESET register

Bit 7	Bit 6	Bit 5	Bit 4	Bit 3	Bit 2	Bit 1	Bit 0
FIFO flush	-	-	-	Soft reset[3:0]			

Table 47 RESET bit fields

Bit Name	Bits	Type	Description
FIFO flush	<7>	W	Setting this bit to 1 clears all data in the measurement results FIFO.
Soft reset[3:0]	<3:0>	W	<p>Two soft reset options are available, depending on the value sent to this bit field.</p> <ul style="list-style-type: none"> 0b1000: Reset configuration registers without eFuse refresh. Duration ~0.7ms. 0b1001: Full reset. Similar to power-on-reset, all registers are reset and eFuses refresh is carried out. Duration ~3ms. <p><i>Note: Only the listed values should be written to the soft reset bit field. Writing incorrect values may result in unexpected behaviour.</i></p>

10.15 PROD_ID

Product ID register storing product and revision information.

Address: 0x1D

Reset Value: 0x1A

Table 48 PROD_ID register

Bit 7	Bit 6	Bit 5	Bit 4	Bit 3	Bit 2	Bit 1	Bit 0
Revision ID[3:0]				Product ID[3:0]			

Table 49 PROD_ID bit fields

Bit Name	Bits	Type	Description
Revision ID[3:0]	<7:4>	R	DPS422 revision number, incremented on metal and silicon revisions.
Product ID[3:0]	<3:0>	R	DPS422 product ID number. Always set to 0xA.

11 Calibration coefficients

The DPS422 register map contains a number of fused coefficients which are used in the calculation of pressure and temperature measurements.

The three temperature measurement coefficients are stored across three registers at addresses 0x20 to 0x22. These coefficients are individually calculated and fused in each DPS422, they must be used to accurately convert the temperature measurement value stored in the results registers TMP_B0 to TMP_B2 into a temperature value in °C.

Pressure calibration coefficients are stored in register addresses 0x26 to 0x39. These coefficients are also individually measured and fused for each DPS422 unit and must be used in the calculation of pressure measurement results to eliminate any measurement non-linearities caused by temperature shift.

The following tables shows the register layout of the calibration coefficients. It is recommended to block read these coefficient registers and then parse according to the bit labellings in the table.

Table 50 DPS422 Temperature Calculation Coefficients

Register Name	Addr.	Bit 7	Bit 6	Bit 5	Bit 4	Bit 3	Bit 2	Bit 1	Bit 0
T_GAIN_COEFF	0x20	T_gain <7:0>							
T_dVBE_COEFF	0x21	T_dVbe<6:0>							
T_VBE_COEFF	0x22	T_Vbe<8:1>							

Table 51 DPS422 Pressure Measurement Calibration Coefficients

Register Name	Addr.	Bit 7	Bit 6	Bit 5	Bit 4	Bit 3	Bit 2	Bit 1	Bit 0
COEFF_REG_1	0x26	C00 <19:12>							
COEFF_REG_2	0x27	C00 <11:4>							
COEFF_REG_3	0x28	C00 <3:0>				C10 <19:16>			
COEFF_REG_4	0x29	C10 <15:8>							
COEFF_REG_5	0x2A	C10 <7:0>							
COEFF_REG_6	0x2B	C01 <19:12>							
COEFF_REG_7	0x2C	C01 <11:4>							
COEFF_REG_8	0x2D	C01 <3:0>				C02 <19:6>			
COEFF_REG_9	0x2E	C02 <15:8>							
COEFF_REG_10	0x2F	C02 <7:0>							
COEFF_REG_11	0x30	-	C20 <14:8>						
COEFF_REG_12	0x31	C20 <7:0>							
COEFF_REG_13	0x32	-	C30 <11:8>						
COEFF_REG_14	0x33	C30 <7:0>							
COEFF_REG_15	0x34	C11 <16:9>							
COEFF_REG_16	0x35	C11 <8:1>							
COEFF_REG_17	0x36	C11 <0>	C12 <16:10>						
COEFF_REG_18	0x37	C12 <9:2>							

Table 51 DPS422 Pressure Measurement Calibration Coefficients (continued)

Register Name	Addr.	Bit 7	Bit 6	Bit 5	Bit 4	Bit 3	Bit 2	Bit 1	Bit 0
COEFF_REG_19	0x38	C12 <1:0>		C21 <13:8>					
COEFF_REG_20	0x39	C21 <7:0>							

11.1 Coefficient number formats

The six temperature calculation coefficients use the following number formats:

Table 52 DPS422 temperature calculation coefficients number format

Coefficient	Format
T_gain	8 bits, 2's complement
T_dVbe	7 bits, 2's complement
T_Vbe	9 bits, 2's complement

The pressure measurement calibration coefficients use the following number formats:

Table 53 DPS422 pressure measurement calibration coefficients number formats

Coefficient	Format
C00	20 bit, 2's complement
C01	20 bit, 2's complement
C02	20 bit, 2's complement
C10	20 bit, 2's complement
C11	17 bit, 2's complement
C12	17 bit, 2's complement
C20	15 bit, 2's complement
C21	14 bit, 2's complement
C30	12 bit, 2's complement

12 Package description

The DPS422 package is an 8 pin LGA, with dimensions 2.0 x 2.5 x 0.73 mm (typ), and 0.65 mm pitch.

12.1 Package drawing

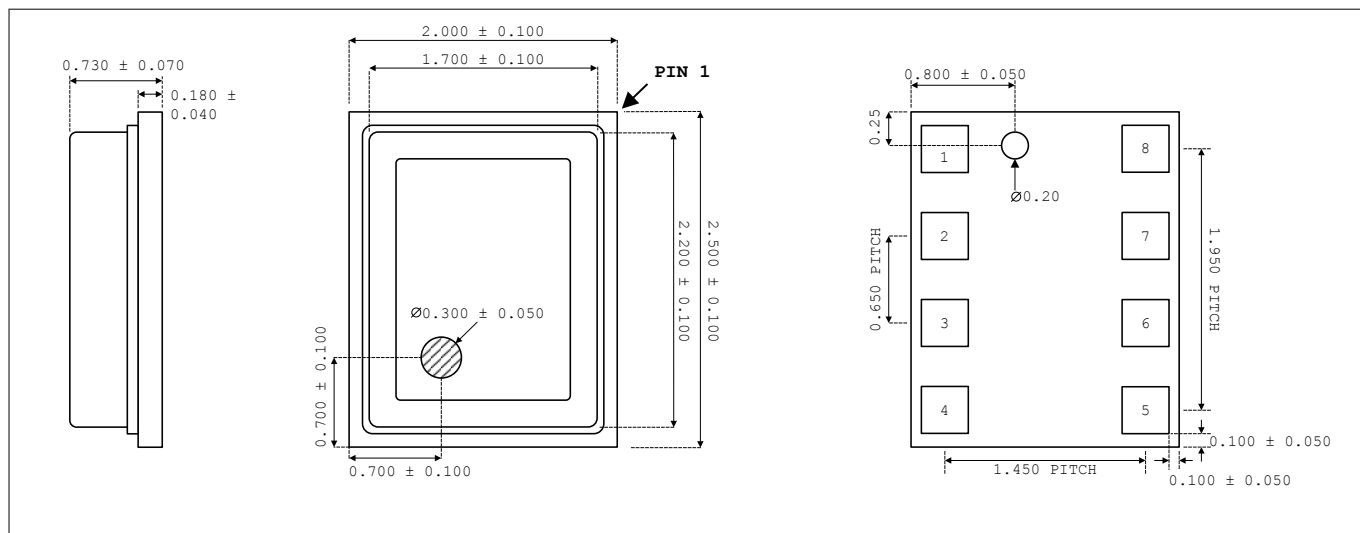

Figure 15 DPS422 package drawing (side view, top view, bottom view)

Revision history

Major changes since previous revision

Revision history

Reference	Description
V1.0	Release datasheet version.
V1.1	First revision
V1.2	Update to temperature coefficients and typical applications
V1.3	Update temperature coefficients, operating range notes and typo fixed; title typo fix

Trademarks

All referenced product or service names and trademarks are the property of their respective owners.

Edition 2018-08-02

Published by
Infineon Technologies AG
81726 Munich, Germany

© 2018 Infineon Technologies AG
All Rights Reserved.

Do you have a question about any
aspect of this document?
Email: erratum@infineon.com

Document reference
IFX-dnz1462876875101

IMPORTANT NOTICE

The information given in this document shall in no event be regarded as a guarantee of conditions or characteristics ("Beschaffheitsgarantie").

With respect to any examples, hints or any typical values stated herein and/or any information regarding the application of the product, Infineon Technologies hereby disclaims any and all warranties and liabilities of any kind, including without limitation warranties of non-infringement of intellectual property rights of any third party.

In addition, any information given in this document is subject to customer's compliance with its obligations stated in this document and any applicable legal requirements, norms and standards concerning customer's products and any use of the product of Infineon Technologies in customer's applications.

The data contained in this document is exclusively intended for technically trained staff. It is the responsibility of customer's technical departments to evaluate the suitability of the product for the intended application and the completeness of the product information given in this document with respect to such application.

WARNINGS

Due to technical requirements products may contain dangerous substances. For information on the types in question please contact your nearest Infineon Technologies office.

Except as otherwise explicitly approved by Infineon Technologies in a written document signed by authorized representatives of Infineon Technologies, Infineon Technologies' products may not be used in any applications where a failure of the product or any consequences of the use thereof can reasonably be expected to result in personal injury

X-ON Electronics

Largest Supplier of Electrical and Electronic Components

Click to view similar products for [Board Mount Pressure Sensors](#) category:

Click to view products by [Infineon](#) manufacturer:

Other Similar products are found below :

[80527-25.0H2-05](#) [80541-B00000150-01](#) [80541-B00000200-05](#) [80554-00700100-05](#) [80568-00300050-01](#) [81618-B00000040-01](#) [81739-B00000900-01](#) [81807-B00000020-01](#) [81808-B00000150-14](#) [82903-B00000020-01](#) [93.631.4253.0](#) [93.731.4353.0](#) [93.932.4553.0](#) [136PC150G2](#) [136PC15A1](#) [142PC95AW71](#) [142PC05DW70](#) [MPXV2202DPT1](#) [15PSI-G-4V](#) [1805-01A-L0N-B](#) [2000317-1](#) [26PCBKT](#) [26PCCFA6D26](#) [26PCCFS2G](#) [26PCCVA6D](#) [93.632.7353.0](#) [93.731.3653.0](#) [93.931.4853.0](#) [93.932.4853.0](#) [SCDA120-XSC05DC](#) [SP370-23-156-0](#) [185PC30DH](#) [192992-0059](#) [20INCH-G-MV-MINI](#) [26PCAFJ3G](#) [26PCAFS2G54](#) [26PCCEP5G24](#) [26PCJEU5G19](#) [30INCH-D1-MV-MINI](#) [ASCX15AN-90](#) [TSCSAAN001PDUCV](#) [DCAL401DN](#) [DCAL401GN](#) [XZ202798SSC](#) [XZ203676HSC](#) [SP370-25-116-0](#) [81717-00000050-05](#) [81794-B00001200-01](#) [HSCDLNN100PGAA5](#) [81618-B00000040-05](#)