

## LOW QUIESCENT CURRENT MOSFET DRIVER

**Features**

- Very low quiescent current on state
- Boost converter with integrated diode
- Standard level gate voltage
- Wide operating voltage 4-36V
- Temperature monitoring with NTC interface
- Lead-Free, Halogen Free, RoHS compliant

**Product Summary**

Operating voltage 4-36V  
V<sub>gate</sub> 11.5V min.  
I<sub>qcc On</sub> 50µA max.

**Applications**

- Battery switch for Stop and Start system

**Description**

The AUIR3240S is a high side mosfet driver for battery switch application where a very low quiescent current is required when the driver is on. The AUIR3240S is a combination of a boost DC/DC converter using an external inductor and a gate driver. It drives standard level Mosfet even at low battery voltage. The input is active low to reduce current consumption.

**Package**

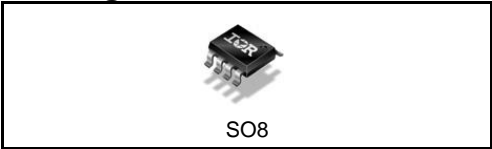

**Typical Connection**

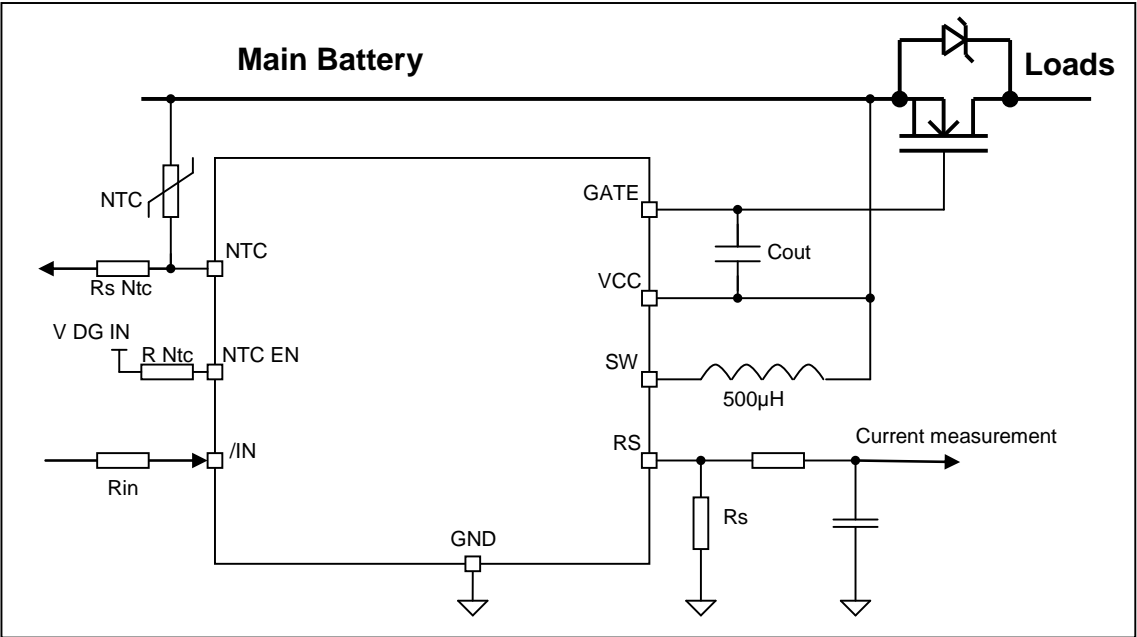

**Qualification Information†**

<b>Qualification Level</b>		Automotive (per AEC-Q100)	
		Comments: This family of ICs has passed an Automotive qualification. IR's Industrial and Consumer qualification level is granted by extension of the higher Automotive level.	
<b>Moisture Sensitivity Level</b>		SOIC-8L	MSL2, 260°C (per IPC/JEDEC J-STD-020)
<b>ESD</b>	Machine Model	Class M0 (+/-50V) (per AEC-Q100-003)	
	Human Body Model	Class H0 (+/-50V) (per AEC-Q100-002)	
	Charged Device Model	Class C4 (+/-1000V) (per AEC-Q100-011)	
<b>IC Latch-Up Test</b>		Yes	
<b>RoHS Compliant</b>		Yes	

† Qualification standards can be found at International Rectifier's web site <http://www.irf.com/>

## Absolute Maximum Ratings

Absolute maximum ratings indicate sustained limits beyond which damage to the device may occur. All voltage parameters are referenced to Ground lead. (Tambient=25°C unless otherwise specified).

Symbol	Parameter	Min.	Max.	Units
Vcc-gnd	Maximum Vcc voltage	-0.3	65	V
Vgate-Vsw	Maximum Vgate-Vsw voltage	-1	65	
Vsw-gnd	Maximum Sw voltage	-0.3	65	
Vrs-gnd	Maximum Rs voltage	-0.3	6	
Vntc	Maximum Ntc voltage	-0.3	65	
Vntc_en	Maximum NTC_EN voltage	-0.3	6	
Vin	Maximum IN pin voltage	-0.3	6	
Isw	Maximum continuous current in SW pin	—	200	
Tj max.	Max. storage & operating temperature junction temperature	-40	150	°C

## Thermal Characteristics

Symbol	Parameter	Typ.	Max.	Units
Rth	Thermal resistance junction to ambient	100	—	°C/W

## Recommended Operating Conditions

Symbol	Parameter	Min.	Max.	Units
VIH	High level input voltage	2.5	5.5	V
VIL	Low level input voltage	0	0.9	
Rs NTC	Serial NTC resistor	4	10	kΩ
Rin	Input resistor	4	10	

## Static Electrical Characteristics

T<sub>j</sub>=-40..125°C, V<sub>cc</sub>=6..16V (unless otherwise specified), typical value are given for V<sub>cc</sub>=14V and T<sub>j</sub>=25°C.

Symbol	Parameter	Min.	Typ.	Max.	Units	Test Conditions	
V <sub>cc op.</sub>	Operating voltage range	4	—	36	V	See page 10	
I <sub>q Vcc Off</sub>	Supply current when Off, T <sub>j</sub> =25°C	—	85	120	μA	V <sub>in</sub> =5V, NTC_EN=0V K1 off, K2 on	
	Supply current when Off, T <sub>j</sub> =125°C	—	110	200			
I <sub>q Vcc On</sub>	Supply current when On, T <sub>j</sub> =25°C	—	2	10		μA	V <sub>in</sub> =0V, NTC_EN=0V K1 off, see page 8
	Supply current when On, T <sub>j</sub> =125°C	—	3	10			
I <sub>q gate On</sub>	Quiescent current on Gate, T <sub>j</sub> =25°C	—	6	20	μA	V <sub>in</sub> =0V, V <sub>gate</sub> =14V K1 off, see page 8	
	Quiescent current on Gate, T <sub>j</sub> =125°C	—	12	40			
V <sub>br gate</sub>	Breakdown voltage between and V <sub>cc</sub>	15	17	20	V	I=10mA	
OV	Over-voltage protection between gate and gnd	50	55	60	V		
I <sub>in</sub>	Input current	—	30	65	μA	V <sub>in</sub> =5V	
V <sub>in th</sub>	IN threshold voltage	1	2	2.5	V	I <sub>gate</sub> =0μA	
V <sub>gs th</sub>	Gate output threshold	11.5	12.5	13.5			
V <sub>rs th</sub>	Rs threshold, T <sub>j</sub> =-40°C	0.9	1.1	1.3			
	Rs threshold, T <sub>j</sub> =25°C	0.85	1	1.2			
	Rs threshold, T <sub>j</sub> =125°C	0.75	0.95	1.2			
R <sub>dson K1</sub>	R <sub>dson</sub> of K1, T <sub>j</sub> =-40°C	—	8	13	Ω	I=100mA	
	R <sub>dson</sub> of K1, T <sub>j</sub> =25°C	—	11	15			
	R <sub>dson</sub> of K1, T <sub>j</sub> =125°C	—	15	20			
R <sub>dson K2</sub>	R <sub>dson</sub> of K2, T <sub>j</sub> =-40°C	—	22	40			
	R <sub>dson</sub> of K2, T <sub>j</sub> =25°C	—	35	45			
	R <sub>dson</sub> of K2, T <sub>j</sub> =125°C	—	60	75			
V <sub>f</sub>	Forward voltage of rectifier diode	—	0.7	1	V	I=100mA	
I <sub>q ntc</sub>	Quiescent current in NTC	—	0.1	1	μA	V <sub>ntc</sub> =16V, V <sub>ntc_en</sub> =0V	
I <sub>Ntc</sub>	Out Ntc current R <sub>ntc</sub> =7k, V <sub>dj in</sub> =5V	—	1	—	mA	V <sub>ntc</sub> >6V	
V <sub>th_ntc_en</sub>	NTC_EN threshold voltage	1.15	1.5	1.9	V	I=500μA	
I <sub>ratio ntc</sub>	Current ratio between NTC_EN and NTC	1.9	2.05	2.2		V <sub>ntc</sub> >6V	

## Timing Converter Characteristics

T<sub>j</sub>=-40..125°C, V<sub>cc</sub>=6..16V (unless otherwise specified), typical value are given for V<sub>cc</sub>=14V and T<sub>j</sub>=25°C.

Symbol	Parameter	Min.	Typ.	Max.	Units	Test Conditions
T <sub>off</sub>	Off time	5	7.5	10	μs	
T <sub>don K1</sub>	Turn-on delay of K1	—	10	—		
T <sub>doff K1</sub>	Turn-off delay of K1	—	0.2	—		

## Switching Characteristics

T<sub>j</sub>=-40..125°C, V<sub>cc</sub>=6..16V (unless otherwise specified), typical value are given for V<sub>cc</sub>=14V and T<sub>j</sub>=25°C.

Symbol	Parameter	Min.	Typ.	Max.	Units	Test Conditions
T <sub>don K2</sub>	Turn-on delay of K2	1	2.5	4	μs	C=100nF
T <sub>f K2</sub>	Fall time of K2 90% to 10% of V <sub>gate</sub> -V <sub>cc</sub>	—	6	20		
I <sub>out- K2</sub>	Gate low short circuit pulsed current	100	350	—	mA	V <sub>gate</sub> =14V

## Lead Definitions

Pin number	Symbol	Description
1	NTC	An NTC resistor can be connected between this pin and the Vcc line close to the tab to sense the temperature of the Mosfet
2	NTC_EN	NTC_EN is the input of the NTC system.
3	/IN	Active low input pin to enable the boost converter or short the gate to Vcc
4	GND	Ground pin
5	RS	Current sense input pin
6	SW	Output of K1
7	VCC	Power supply
8	GATE	Output of the boost converter

## Lead Assignments

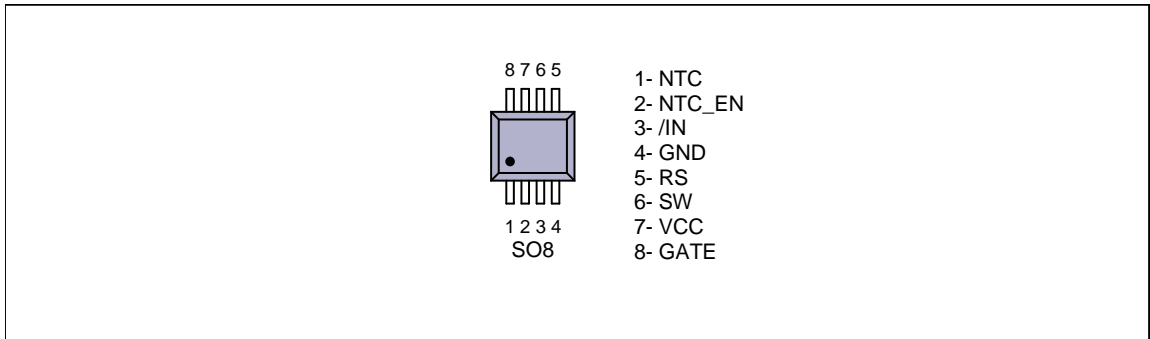

## Block diagram

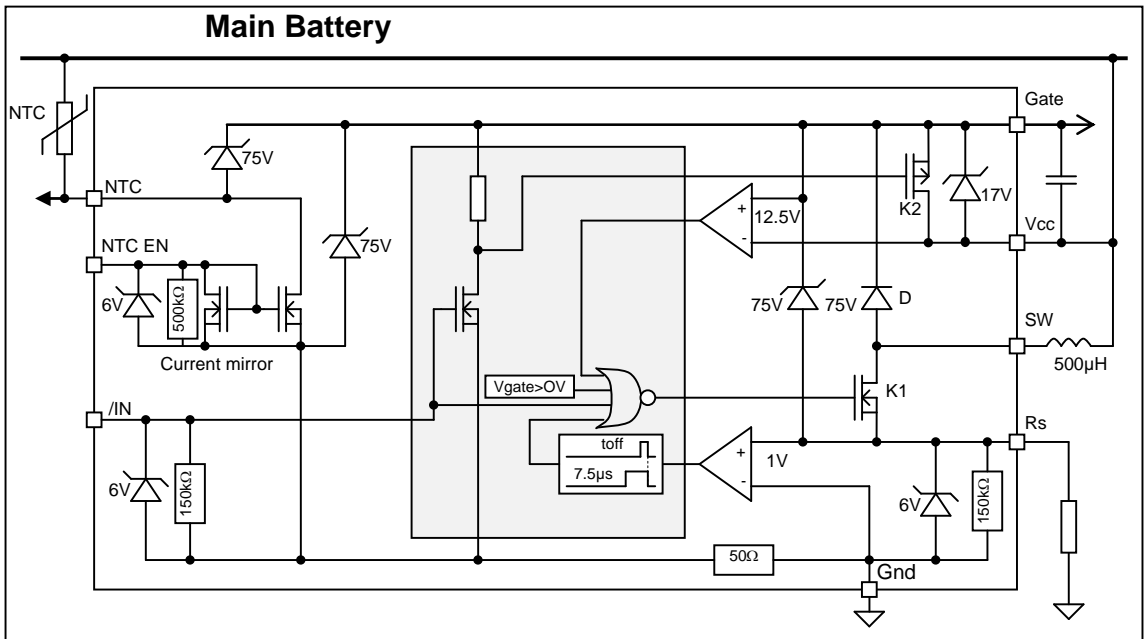

## Description

The topology of the AUIR3240S is a boost DC/DC converter working in current mode. K1 is switched on when the gate voltage is lower than  $V_{gs}$  threshold. When  $R_s$  pin reaches  $V_{rs}$  th, K1 is turned off and the inductor charge the gate capacitor through D. The system cannot restart during  $T_{off}$  after  $V_{rs}$  th has been reached. The DC/DC restart only when the Gate and the  $V_{cc}$  voltage difference is lower than 12.5V in order to achieve low quiescent current on the power supply.

To turn off the power Mosfet, the input must be pull high. Then the DC/DC converter is turned and K2 shorts the gate to  $V_{cc}$ .

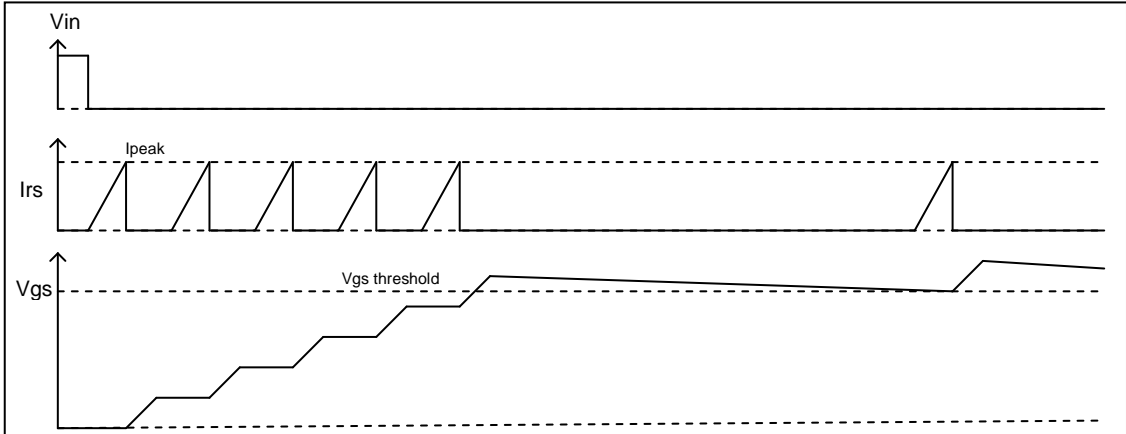

## Parameters definition

### Current definition

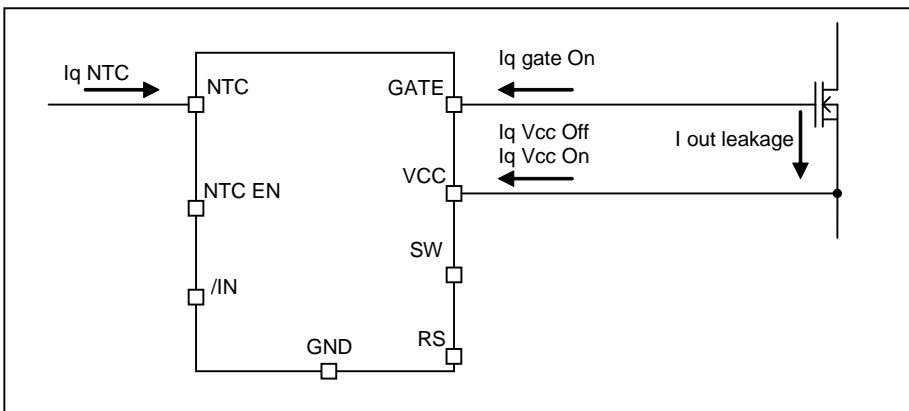

## Timing definition

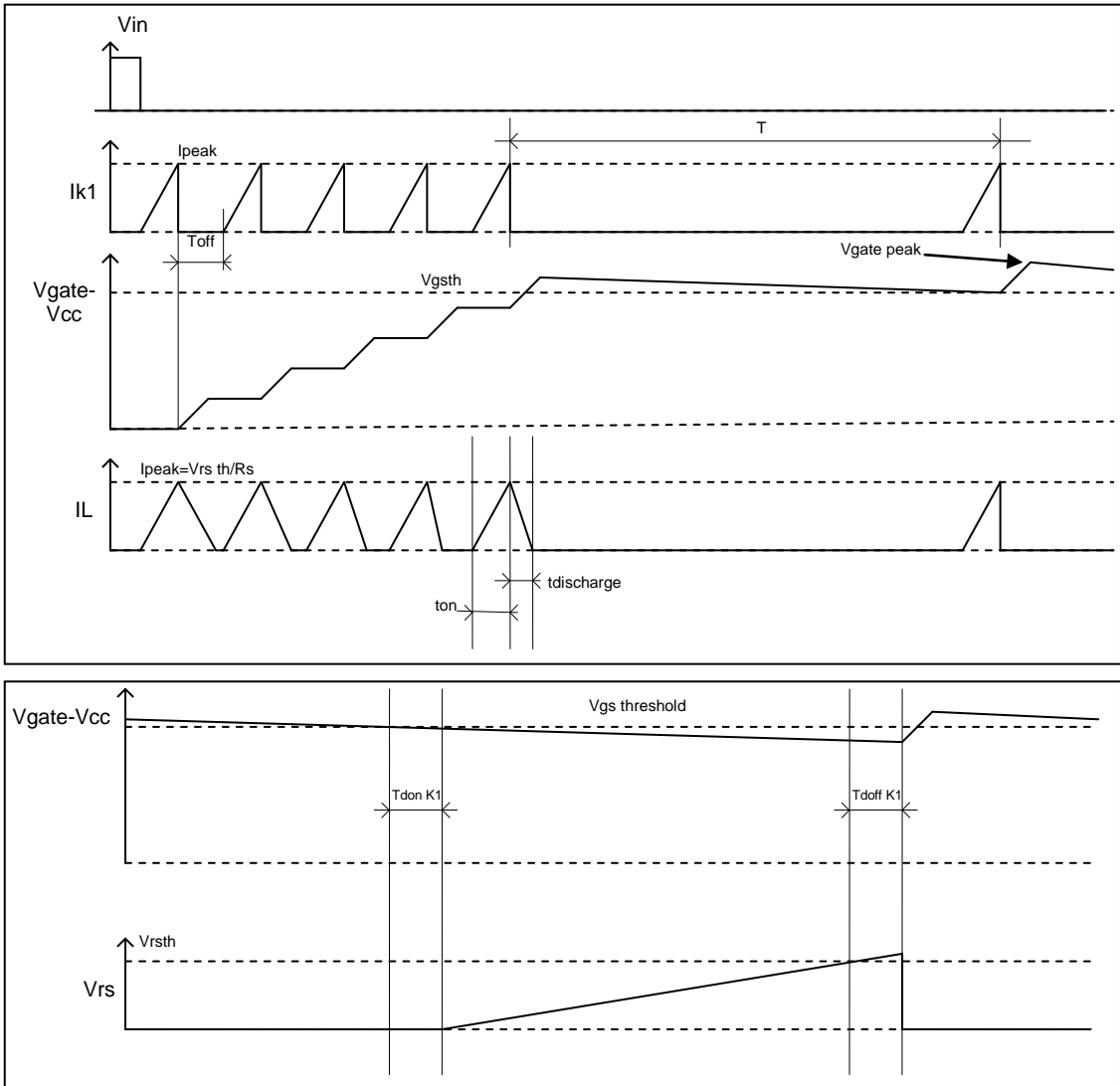

## Low quiescent current operation when On.

The AUIR3240S is able to operate with a very low quiescent current on the Vcc pin. Nevertheless the supply current depends also on the leakage of the power mosfet named "I out leakage" on the diagram below.

The leakage current is given when K1 is off. When K1 is on, the current flowing in Vcc is the current charging the inductor. Therefore the average current on the Vcc is the combination of the current when K1 is ON and OFF. The average current on the Vcc pin can be calculated using:



$$I_{vcc\ ave} = (I_{q\ gate} + I_{out\ leakage}) * \frac{V_{gate} - V_{cc} + V_f}{V_{cc}} + I_{q\ Vcc\ on} + I_{q\ gate\ on} + I_{q\ NTC}$$

With  $V_{gate}$ : the average voltage on the output.

$$V_{gate\ average} = (V_{gate\ peak} + V_{gsth})/2$$

$V_{gate\ peak}$  can be calculated by:

$$V_{gate\ peak} = \sqrt{\frac{L}{C_{out}} * I_{peak}^2 + V_{gsth}^2}$$

During On operation, the DC/DC works in pulse mode, meaning each time the  $V_{gate}-V_{cc}$  voltage comes below 12.5V, the AUIR3240S switches on K1 to recharge the gate voltage. When the  $I_{out\ leakage}$  is low enough to maintain the DC/DC in discontinuous mode, the frequency is calculate by:

$$T = \frac{I_{peak}^2 * L}{2 * (I_{q\ gate} + I_{out\ leakage}) * (V_{gate} - V_{cc} + V_f)}$$

## Peak current control

The current in the inductor is limited by the 1V comparator which monitors the voltage across  $R_s$ . Due to the delay in the loop ( $t_{doff\ K1}$ ), the inductor current will exceed the threshold set by:  $\frac{V_{rsth}}{R_s}$

At low voltage, the current waveform in the inductor is not anymore linear, but exponential because the sum of the resistor of K1, the inductor and  $R_s$  are not any more negligible.

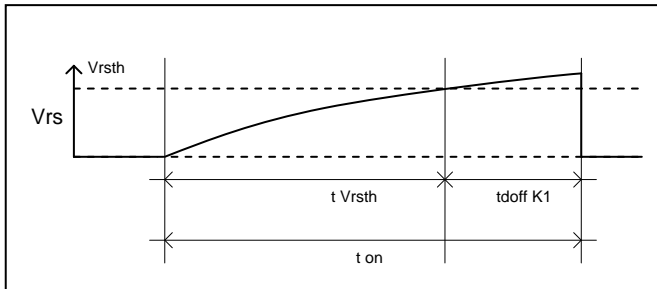

The peak current and  $t_{on}$  can be calculated as follow:

$$t_{Vrsth} = -\frac{L}{R_{k1} + R_s + R_l} * \ln\left(1 - \frac{(R_s + R_{k1} + R_l) * V_{rsth}}{R_s * V_{cc}}\right)$$

Where  $R_l$  is the resistor of the inductor

$$\text{With : } t_{on} = t_{Vrsth} + t_{doff\ K1}$$

The peak current can be solved by:

$$I_{peak} = \frac{V_{cc}}{R_{k1} + R_s + R_l} * \left(1 - e^{-t_{on} * \frac{R_{k1} + R_s + R_l}{L}}\right)$$

## Output voltage Characteristic

In most of case when the output of the AUIR3240S is able to recharge the capacitor higher than  $V_{gsth}$ , the output voltage will oscillate between  $V_{gsth}$  and  $V_{gate\ peak}$ .  $V_{gate\ peak}$  can be calculated by:

$$V_{gate\ peak} = \sqrt{\frac{L}{C_{out}} * I_{peak}^2 + V_{gsth}^2}$$

## Minimum operating voltage

While the AUIR3240S operating voltage is specified between 4V and 36V. The minimum voltage is limited by the fact that the  $R_s$  voltage must reach the  $V_{rsth}$  taking account all resistors which limit the inductor current.

$$V_{cc\ min} = \frac{R_{k1} + R_s + R_l}{R_s} * V_{rsth}$$

## Over-Voltage protection

The AUIR3240S integrates an over-voltage protection in order to protect K1. When  $V_{cc}$  exceed the Over-voltage threshold, the DC/DC is stopped.

## NTC interface

The NTC interface allows the system to have a temperature measurement of the mosfet using one resistor and one NTC. The NTC must be connected to  $V_{cc}$  and close to the tab of the power Mosfet to have a good temperature sensing. The system works as a current mirror between  $NTC\_EN$  and NTC pins. The typical ratio is 2, with 500 $\mu$ A flowing into  $NTC\_EN$ , 1mA will flow in the NTC. The current in the NTC is fixed by adjusting  $R_{Ntc}$  and  $V_{Dg\_In}$ . With 7k and 5V, the current in the NTC will be 1mA. The NTC function activated only if  $NTC\_EN$  is powered.

If the NTC feature function is not used, NTC EN and NTC must be remained floating. The low consumption is achieved only when the NTC interface is not activated.

## Output current measurement

The average current into  $R_s$  can be measured by adding a low pass filter before the ADC of the micro controller. Then the average output current can be evaluated using :

$$I_{out\ av} = I_{Rs\ av} * V_{cc} / (V_{gate} - V_{cc})$$

Knowing the output current can be useful to do a diagnostic on the power Mosfet. If the gate is short, the output current will be significantly higher than in normal operation.

Figures are given for typical value,  $V_{cc}=14V$  and  $T_j=25^{\circ}C$  otherwise specified

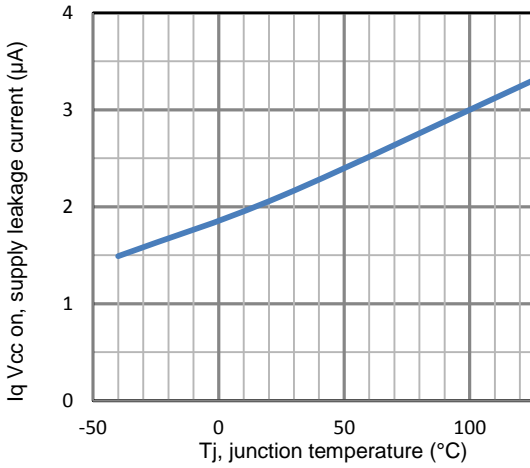

**Figure 1 – Iq Vcc on (µA) Vs Tj (°C)**

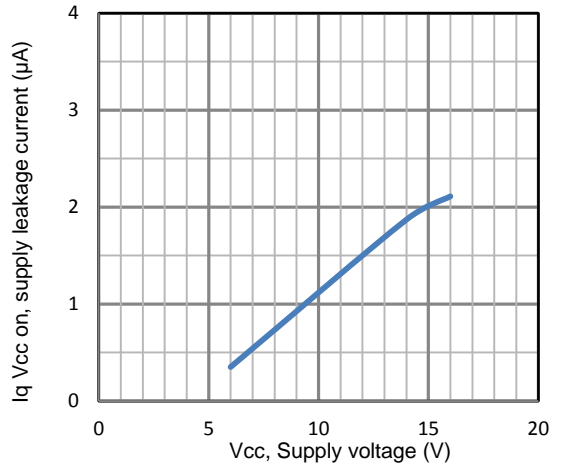

**Figure 2 – Iq Vcc on (µA) Vs Vcc(V)**

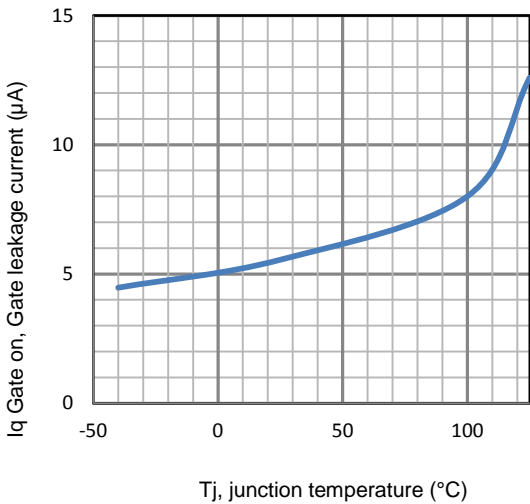

**Figure 3 – Iq Gate on (µA) Vs Tj (°C)**

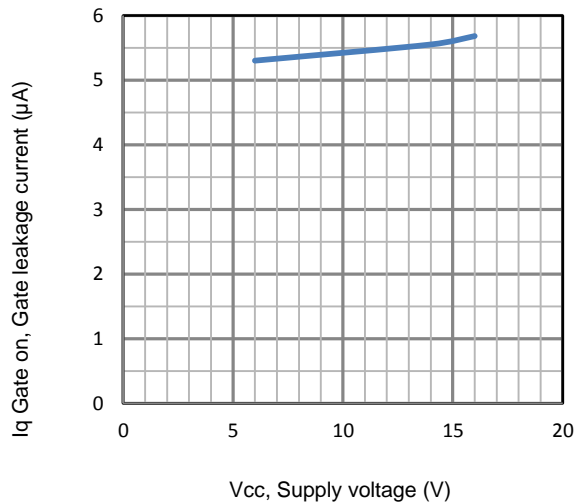

**Figure 4 – Iq Gate on (µA) Vs Vcc(V)**

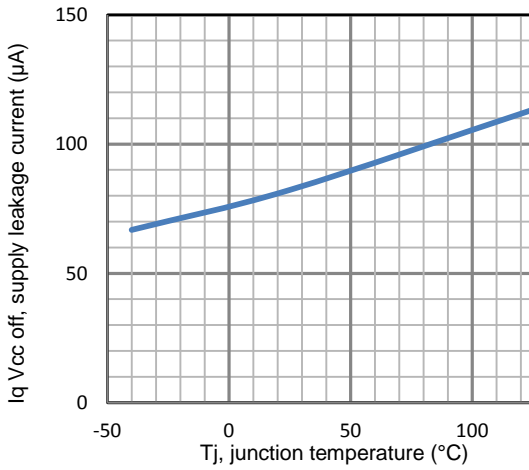

**Figure 5 – Iq Vcc off (µA) Vs Tj (°C)**

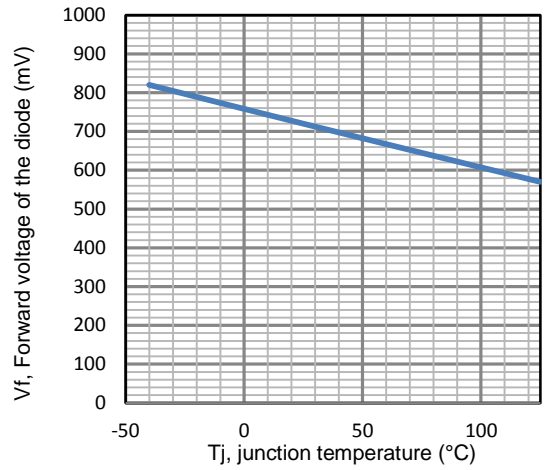

**Figure 6 – Vf (mV) Vs Tj (°C)**

## Case Outline – S08

Dimensions are shown in millimeters (inches)

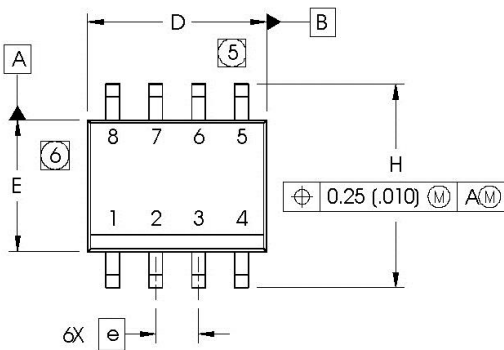

DIM	INCHES		MILLIMETERS	
	MIN	MAX	MIN	MAX
A	.0532	.0688	1.35	1.75
A1	.0040	.0098	0.10	0.25
b	.013	.020	0.33	0.51
c	.0075	.0098	0.19	0.25
D	.189	.1968	4.80	5.00
E	.1497	.1574	3.80	4.00
e	.050 BASIC		1.27 BASIC	
e1	.025 BASIC		0.635 BASIC	
H	.2284	.2440	5.80	6.20
K	.0099	.0196	0.25	0.50
L	.016	.050	0.40	1.27
y	0°	8°	0°	8°

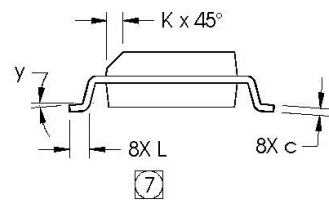
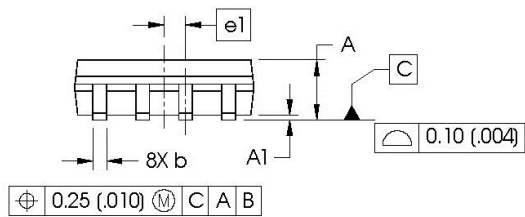

### NOTES:

1. DIMENSIONING & TOLERANCING PER ASME Y14.5M-1994.
2. CONTROLLING DIMENSION: MILLIMETER
3. DIMENSIONS ARE SHOWN IN MILLIMETERS (INCHES).
4. OUTLINE CONFORMS TO JEDEC OUTLINE MS-012AA.
- 5 DIMENSION DOES NOT INCLUDE MOLD PROTRUSIONS. MOLD PROTRUSIONS NOT TO EXCEED 0.15 (.006).
- 6 DIMENSION DOES NOT INCLUDE MOLD PROTRUSIONS. MOLD PROTRUSIONS NOT TO EXCEED 0.25 (.010).
- 7 DIMENSION IS THE LENGTH OF LEAD FOR SOLDERING TO A SUBSTRATE.

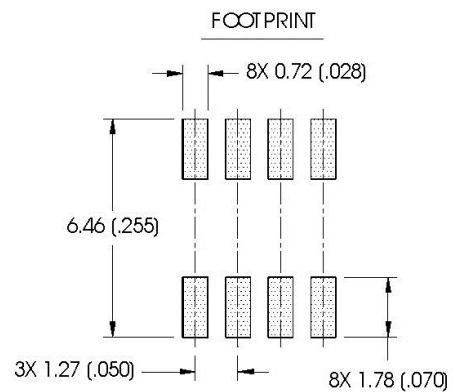

## Tape & Reel SO8

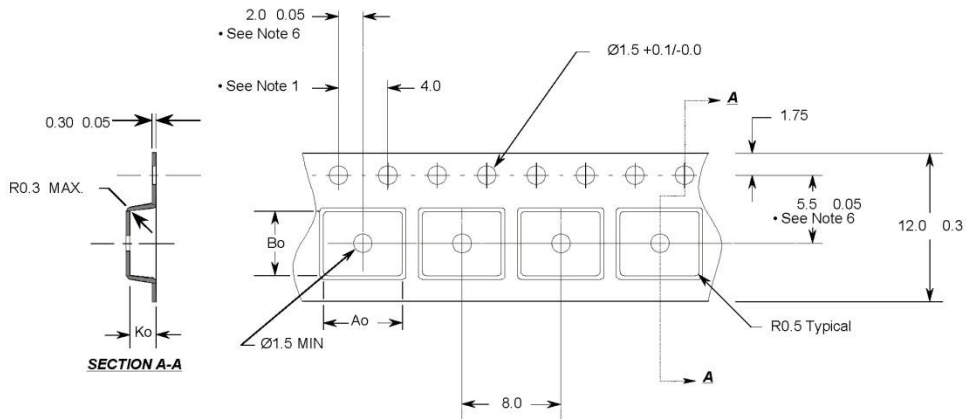

**Notes:**

1. 10 sprocket hole pitch cumulative tolerance 0.2
2. Camber not to exceed 1mm in 100mm
3. Material: Black Conductive Advantek Polystyrene
4. Ao and Bo measured on a plane 0.3mm above the bottom of the pocket
5. Ko measured from a plane on the inside bottom of the pocket to the top surface of the carrier.
6. Pocket position relative to sprocket hole measured as true position of pocket, not pocket hole.

Ao = 6.4 mm  
Bo = 5.2 mm  
Ko = 2.1 mm

- All Dimensions in Millimeters -

## Part Marking Information

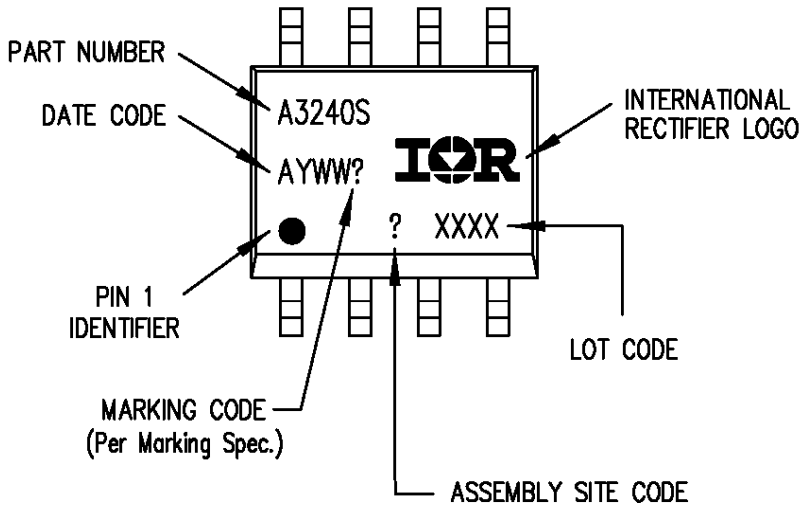

## Ordering Information

Base Part Number	Package Type	Standard Pack		Complete Part Number
		Form	Quantity	
AUIR3240S	SOIC8	Tape and reel	2500	AUIR3240STR

**Published by  
Infineon Technologies AG  
81726 München, Germany  
© Infineon Technologies AG 2015  
All Rights Reserved.**

### **IMPORTANT NOTICE**

The information given in this document shall in no event be regarded as a guarantee of conditions or characteristics (“Beschaffenhheitsgarantie”). With respect to any examples, hints or any typical values stated herein and/or any information regarding the application of the product, Infineon Technologies hereby disclaims any and all warranties and liabilities of any kind, including without limitation warranties of non-infringement of intellectual property rights of any third party.

In addition, any information given in this document is subject to customer’s compliance with its obligations stated in this document and any applicable legal requirements, norms and standards concerning customer’s products and any use of the product of Infineon Technologies in customer’s applications.

The data contained in this document is exclusively intended for technically trained staff. It is the responsibility of customer’s technical departments to evaluate the suitability of the product for the intended application and the completeness of the product information given in this document with respect to such application.

For further information on the product, technology, delivery terms and conditions and prices please contact your nearest Infineon Technologies office ([www.infineon.com](http://www.infineon.com)).

### **WARNINGS**

Due to technical requirements products may contain dangerous substances. For information on the types in question please contact your nearest Infineon Technologies office.

Except as otherwise explicitly approved by Infineon Technologies in a written document signed by authorized representatives of Infineon Technologies, Infineon Technologies’ products may not be used in any applications where a failure of the product or any consequences of the use thereof can reasonably be expected to result in personal injury.



**Revision History**

<b>Revision</b>	<b>Date</b>	<b>Notes/Changes</b>
A	December 10th, 2011	Initial release
B	March, 28 <sup>th</sup> 2012	Page4 correct temperature condition for Vrsth +125°C
C	April, 2 <sup>nd</sup> 2012	Update maximum operating temperature
D	July, 17 <sup>th</sup> 2012	Update page 4, Tdon K1 typ.
E	November, 19 <sup>th</sup> 2012	Update formula page 9 tVrsth
F	October, 17 <sup>th</sup> 2013	Update NTC interface current page10
G	October 31, 2014	Update limit max Rdson K2
H	October 10, 2015	Update the template Update OV definition Update ordering information
I	December 21, 216	Update Ivcc formula page 9
J	April 11, 2016	Update Tdon K1 and Tdoff K1
1.1	April 28, 2016	Update revision name

## X-ON Electronics

Largest Supplier of Electrical and Electronic Components

*Click to view similar products for [Gate Drivers](#) category:*

*Click to view products by [Infineon](#) manufacturer:*

Other Similar products are found below :

[00053P0231](#) [56956](#) [57.404.7355.5](#) [LT4936](#) [57.904.0755.0](#) [5882900001](#) [00600P0005](#) [00-9050-LRPP](#) [00-9090-RDPP](#) [5951900000](#) [01-1003W-10/32-15](#) [0131700000](#) [00-2240](#) [LTP70N06](#) [LVP640](#) [5J0-1000LG-SIL](#) [LY1D-2-5S-AC120](#) [LY2-US-AC240](#) [LY3-UA-DC24](#) [00576P0020](#) [00600P0010](#) [LZN4-UA-DC12](#) [LZNQ2M-US-DC5](#) [LZNQ2-US-DC12](#) [LZP40N10](#) [00-8196-RDPP](#) [00-8274-RDPP](#) [00-8275-RDNP](#) [00-8722-RDPP](#) [00-8728-WHPP](#) [00-8869-RDPP](#) [00-9051-RDPP](#) [00-9091-LRPP](#) [00-9291-RDPP](#) [0207100000](#) [0207400000](#) [01312](#) [0134220000](#) [60713816](#) [M15730061](#) [61161-90](#) [61278-0020](#) [6131-204-23149P](#) [6131-205-17149P](#) [6131-209-15149P](#) [6131-218-17149P](#) [6131-220-21149P](#) [6131-260-2358P](#) [6131-265-11149P](#) [CS1HCPU63](#)