

**NPN Silicon AF Transistor**

- For general AF applications
- High collector current
- High current gain
- Low collector-emitter saturation voltage
- Pb-free (RoHS compliant) package
- Qualified according AEC Q101



| Type       | Marking | Pin Configuration |       |       |   |   |   | Package |
|------------|---------|-------------------|-------|-------|---|---|---|---------|
|            |         | 1 = B             | 2 = E | 3 = C | - | - | - |         |
| BC817K-16  | 6As     | 1 = B             | 2 = E | 3 = C | - | - | - | SOT23   |
| BC817K-16W | 6As     | 1 = B             | 2 = E | 3 = C | - | - | - | SOT323  |
| BC817K-25  | 6Bs     | 1 = B             | 2 = E | 3 = C | - | - | - | SOT23   |
| BC817K-25W | 6Bs     | 1 = B             | 2 = E | 3 = C | - | - | - | SOT323  |
| BC817K-40  | 6Cs     | 1 = B             | 2 = E | 3 = C | - | - | - | SOT23   |
| BC817K-40W | 6Cs     | 1 = B             | 2 = E | 3 = C | - | - | - | SOT323  |
| BC818K-16W | 6Es     | 1 = B             | 2 = E | 3 = C | - | - | - | SOT323  |
| BC818K-40  | 6Gs     | 1 = B             | 2 = E | 3 = C | - | - | - | SOT23   |

**Maximum Ratings**

| Parameter  | Symbol    | Value       | Unit |
|--|-----------|-------------|------|
| Collector-emitter voltage<br>BC817...<br>BC818...  | $V_{CEO}$ | 45<br>25    | V    |
| Collector-base voltage<br>BC817...<br>BC818...   | $V_{CBO}$ | 50<br>30    |      |
| Emitter-base voltage   | $V_{EBO}$ | 5           |      |
| Collector current  | $I_C$     | 500         | mA   |
| Peak collector current   | $I_{CM}$  | 1000        |      |
| Base current   | $I_B$     | 100         |      |
| Peak base current  | $I_{BM}$  | 200         |      |
| Total power dissipation-<br>$T_S \leq 115\text{ °C}$ , BC817K, BC818K<br>$T_S \leq 130\text{ °C}$ , BC817KW, BC818KW | $P_{tot}$ | 500<br>250  | mW   |
| Junction temperature   | $T_j$     | 150         | °C   |
| Storage temperature  | $T_{stg}$ | -65 ... 150 |      |

**Thermal Resistance**

| Parameter  | Symbol     | Value                  | Unit |
|--|------------|------------------------|------|
| Junction - soldering point <sup>1)</sup><br>BC817K, BC818K<br>BC817KW, BC818KW | $R_{thJS}$ | $\leq 70$<br>$\leq 80$ | K/W  |

<sup>1</sup>For calculation of  $R_{thJA}$  please refer to Application Note AN077 (Thermal Resistance Calculation)

**Electrical Characteristics at  $T_A = 25^\circ\text{C}$ , unless otherwise specified**

| Parameter  | Symbol        | Values                  |                        |                        | Unit          |
|--|---------------|-------------------------|------------------------|------------------------|---------------|
|  |               | min.                    | typ.                   | max.                   |               |
| <b>DC Characteristics</b>  |               |                         |                        |                        |               |
| Collector-emitter breakdown voltage<br>$I_C = 10\text{ mA}$ , $I_B = 0$ , BC817...<br>$I_C = 10\text{ mA}$ , $I_B = 0$ , BC818...  | $V_{(BR)CEO}$ | 45<br>25                | -<br>-                 | -<br>-                 | V             |
| Collector-base breakdown voltage<br>$I_C = 10\text{ }\mu\text{A}$ , $I_E = 0$ , BC817...<br>$I_C = 10\text{ }\mu\text{A}$ , $I_E = 0$ , BC818...   | $V_{(BR)CBO}$ | 50<br>30                | -<br>-                 | -<br>-                 | -             |
| Emitter-base breakdown voltage<br>$I_E = 10\text{ }\mu\text{A}$ , $I_C = 0$  | $V_{(BR)EBO}$ | 5                       | -                      | -                      | V             |
| Collector-base cutoff current<br>$V_{CB} = 25\text{ V}$ , $I_E = 0$<br>$V_{CB} = 25\text{ V}$ , $I_E = 0$ , $T_A = 150^\circ\text{C}$  | $I_{CBO}$     | -<br>-                  | -<br>-                 | 0.1<br>50              | $\mu\text{A}$ |
| Emitter-base cutoff current<br>$V_{EB} = 4\text{ V}$ , $I_C = 0$   | $I_{EBO}$     | -                       | -                      | 100                    | nA            |
| DC current gain <sup>1)</sup><br>$I_C = 100\text{ mA}$ , $V_{CE} = 1\text{ V}$ , $h_{FE}$ -grp.16<br>$I_C = 100\text{ mA}$ , $V_{CE} = 1\text{ V}$ , $h_{FE}$ -grp.25<br>$I_C = 100\text{ mA}$ , $V_{CE} = 1\text{ V}$ , $h_{FE}$ -grp.40<br>$I_C = 500\text{ mA}$ , $V_{CE} = 1\text{ V}$ , all $h_{FE}$ -grps. | $h_{FE}$      | 100<br>160<br>250<br>40 | 160<br>250<br>350<br>- | 250<br>400<br>630<br>- | -             |
| Collector-emitter saturation voltage <sup>1)</sup><br>$I_C = 500\text{ mA}$ , $I_B = 50\text{ mA}$   | $V_{CEsat}$   | -                       | -                      | 0.7                    | V             |
| Base emitter saturation voltage <sup>1)</sup><br>$I_C = 500\text{ mA}$ , $I_B = 50\text{ mA}$  | $V_{BEsat}$   | -                       | -                      | 1.2                    |               |

<sup>1)</sup>Pulse test:  $t < 300\mu\text{s}$ ;  $D < 2\%$

**Electrical Characteristics** at  $T_A = 25^\circ\text{C}$ , unless otherwise specified

| Parameter   | Symbol   | Values |      |      | Unit |
|---|----------|--------|------|------|------|
|   |          | min.   | typ. | max. |      |
| <b>AC Characteristics</b>   |          |        |      |      |      |
| Transition frequency<br>$I_C = 50\text{ mA}, V_{CE} = 5\text{ V}, f = 100\text{ MHz}$ | $f_T$    | -      | 170  | -    | MHz  |
| Collector-base capacitance<br>$V_{CB} = 10\text{ V}, f = 1\text{ MHz}$                | $C_{cb}$ | -      | 3    | -    | pF   |
| Emitter-base capacitance<br>$V_{EB} = 0.5\text{ V}, f = 1\text{ MHz}$                 | $C_{eb}$ | -      | 40   | -    |      |

**DC current gain  $h_{FE} = f(I_C)$**

$V_{CE} = 1\text{ V}$

$h_{FE}\text{-grp.16}$

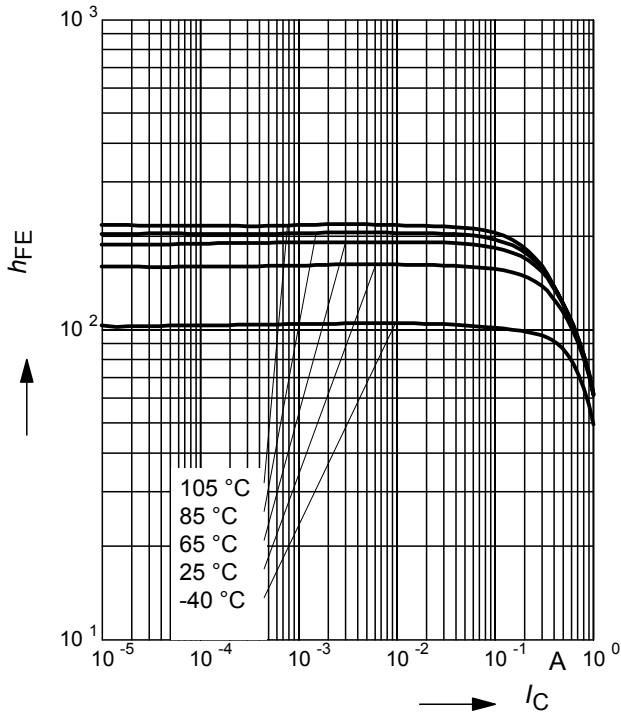

**DC current gain  $h_{FE} = f(I_C)$**

$V_{CE} = 1\text{ V}$

$h_{FE}\text{-grp.25}$

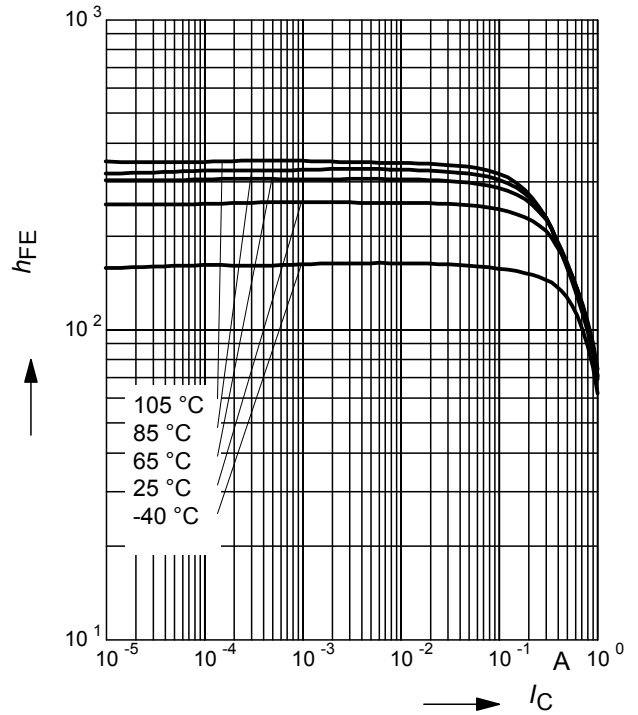

**DC current gain  $h_{FE} = f(I_C)$**

$V_{CE} = 1\text{ V}$

$h_{FE}\text{-grp.40}$

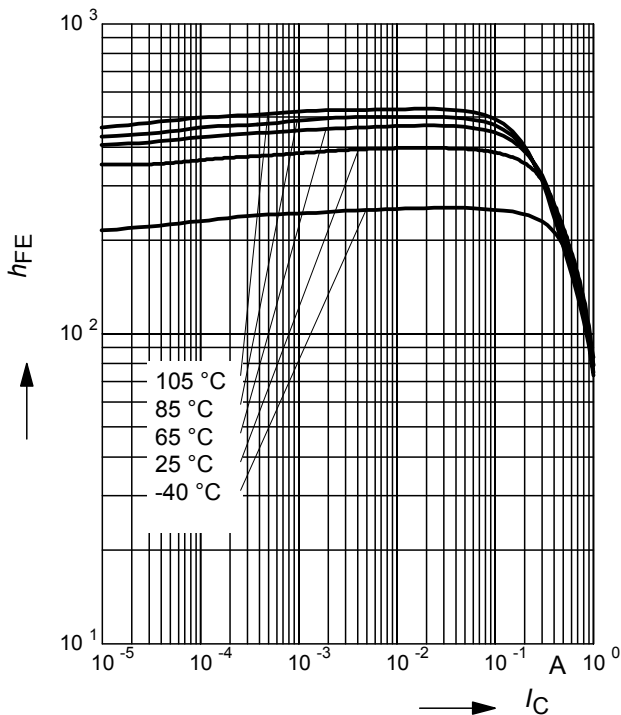

**Collector-emitter saturation voltage**

$I_C = f(V_{CEsat}), h_{FE} = 10$

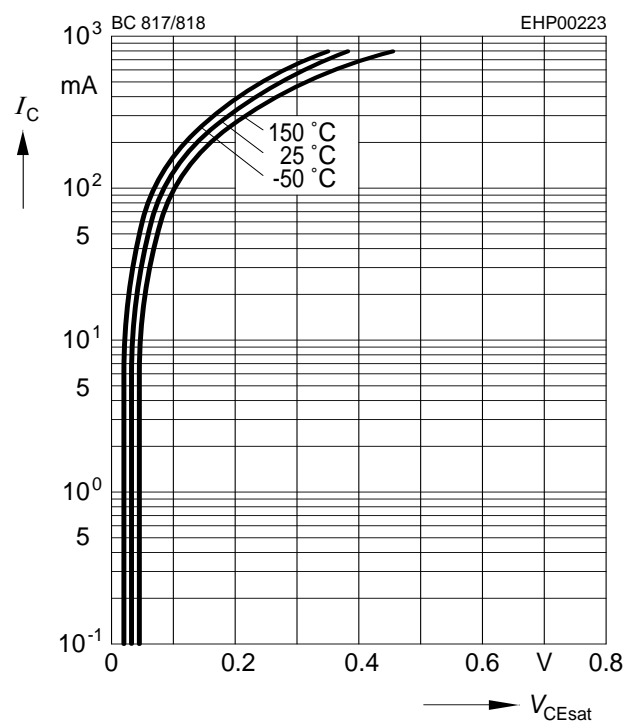

**Base-emitter saturation voltage**

$I_C = f(V_{BEsat}), h_{FE} = 10$

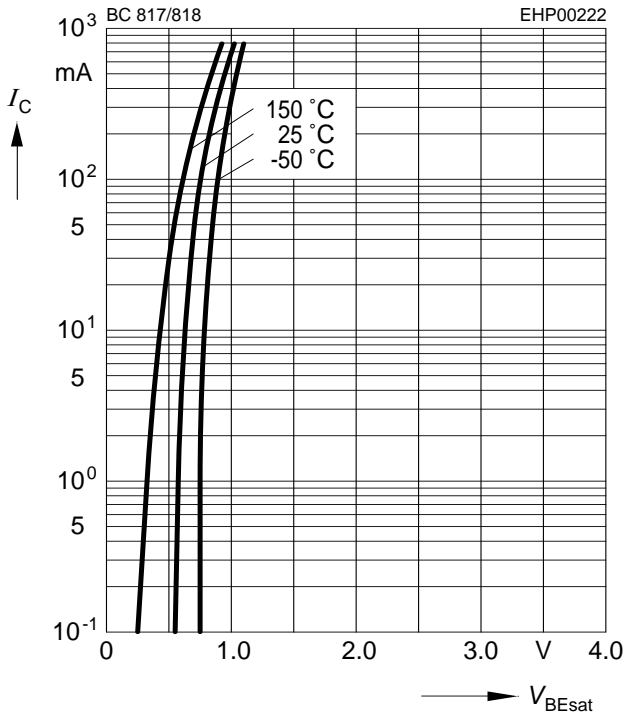

**Collector cutoff current  $I_{CBO} = f(T_A)$**

$V_{CBO} = 25 V$

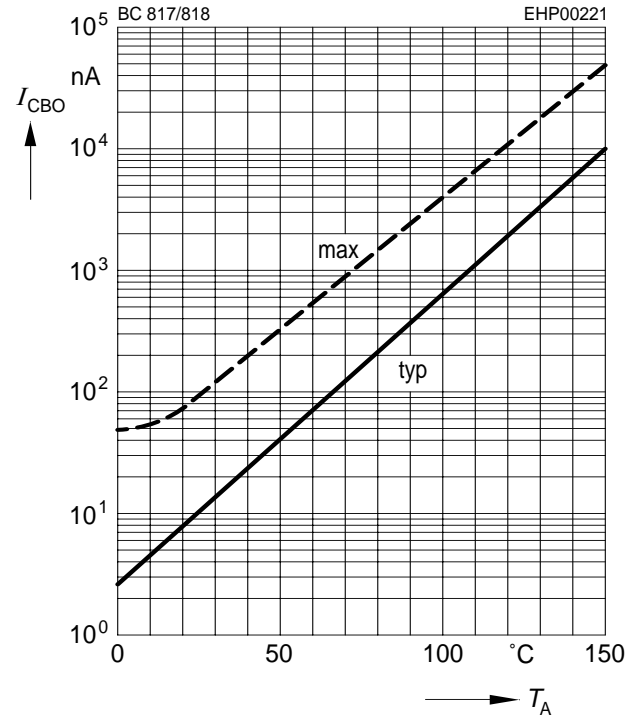

**Transition frequency  $f_T = f(I_C)$**

$V_{CE} = \text{parameter in V}, f = 2 \text{ GHz}$

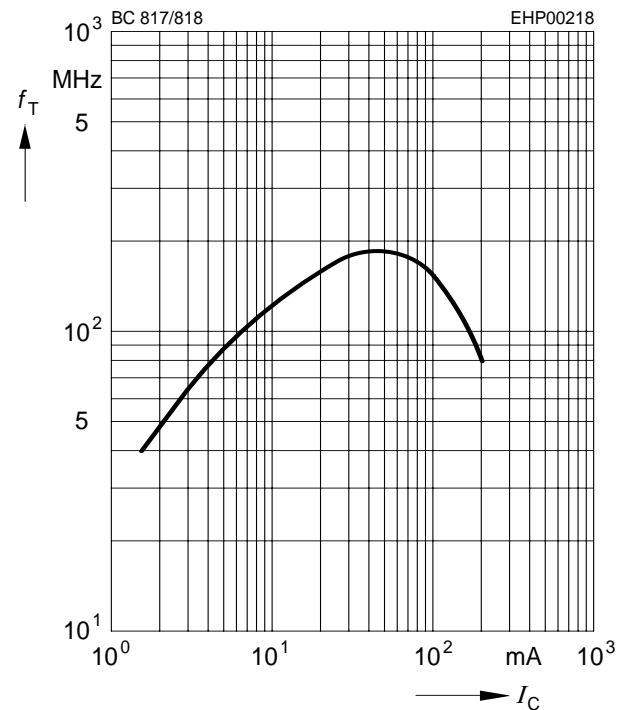

**Collector-base capacitance  $C_{cb} = f(V_{CB})$**

**Emitter-base capacitance  $C_{eb} = f(V_{EB})$**

BC817K, BC818K

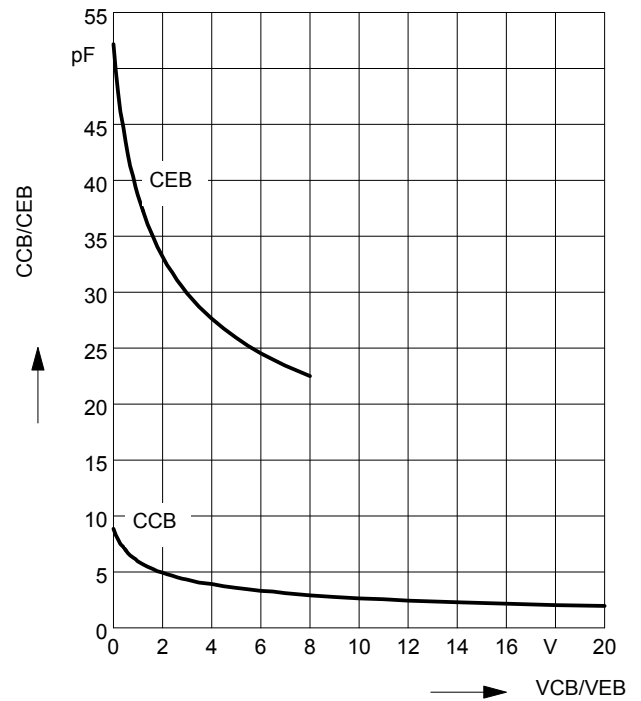

**Total power dissipation  $P_{tot} = f(T_S)$**

BC817K, BC818K

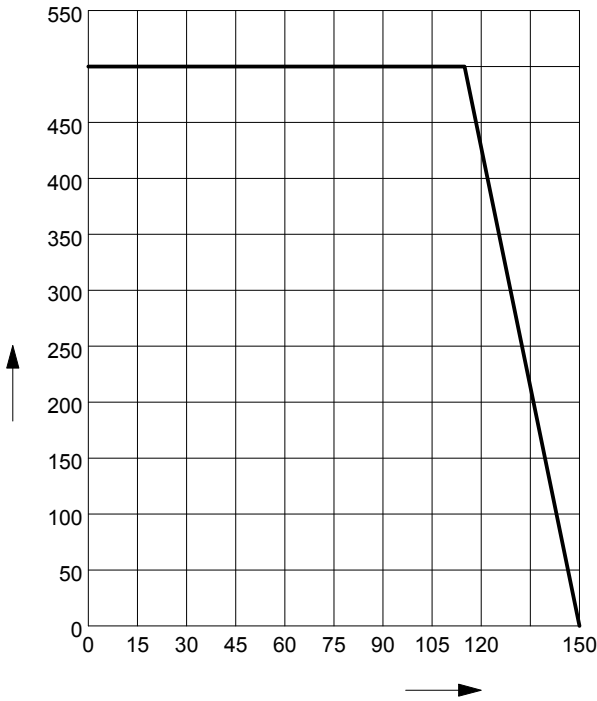

**Total power dissipation  $P_{tot} = f(T_S)$**

BC817KW, BC818KW

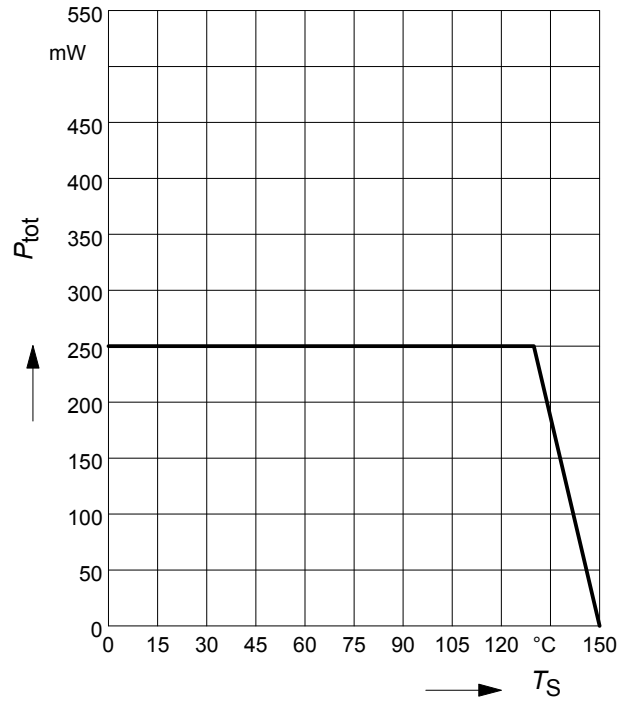

**Permissible Pulse Load  $R_{thJS} = f(t_p)$**

BC817K, BC818K

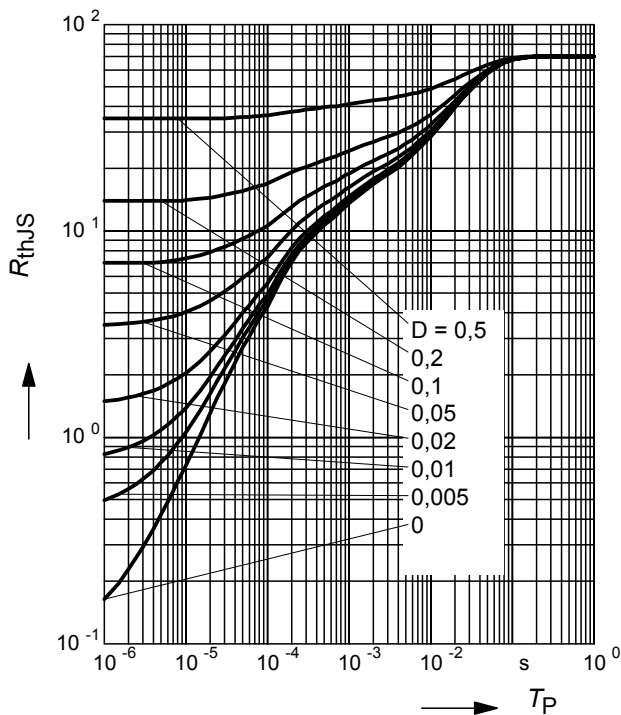

**Permissible Pulse Load**

$P_{totmax}/P_{totDC} = f(t_p)$

BC817K, BC818K

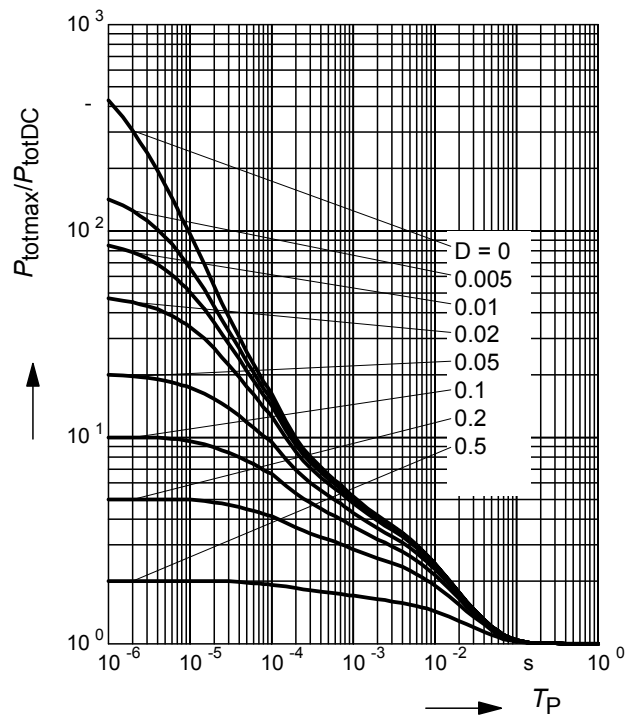

**Permissible Puls Load  $R_{thJS} = f(t_p)$**

BC817KW, BC818KW

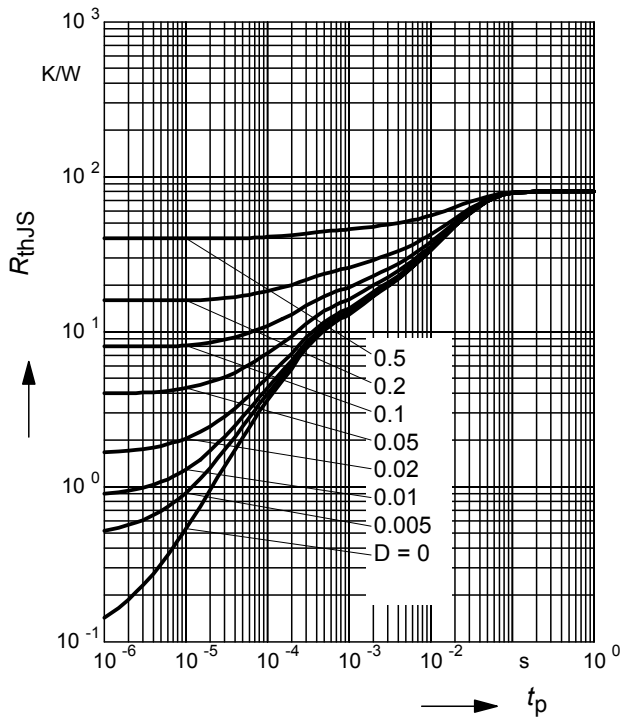

**Permissible Pulse Load**

$P_{totmax}/P_{totDC} = f(t_p)$

BC817KW, BC818KW

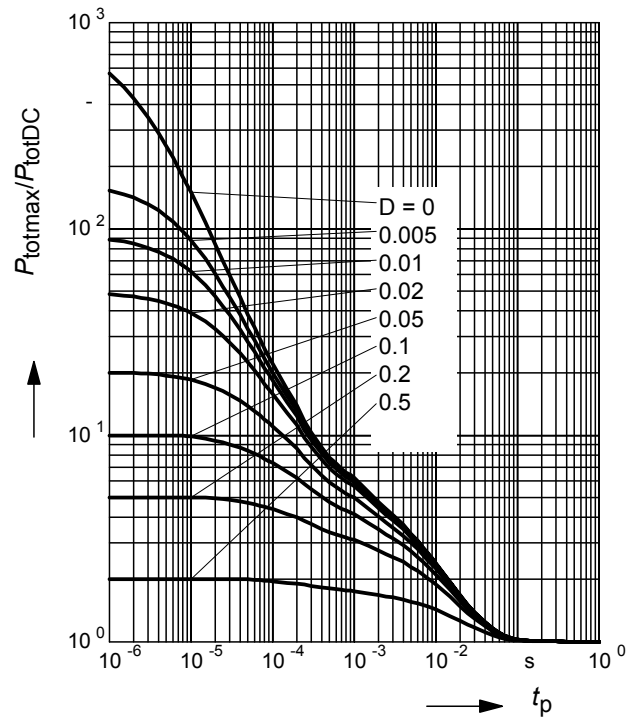



Package Outline



1) Lead width can be 0.6 max. in dambar area

Foot Print

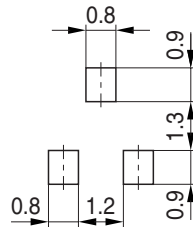

Marking Layout (Example)

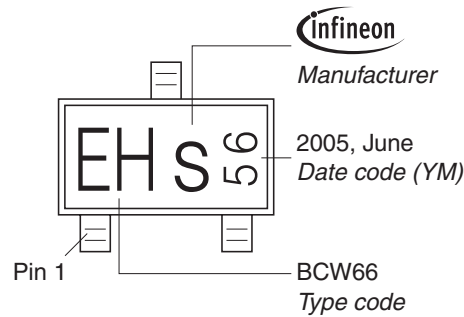

Standard Packing

Reel  $\varnothing$ 180 mm = 3.000 Pieces/Reel  
 Reel  $\varnothing$ 330 mm = 10.000 Pieces/Reel

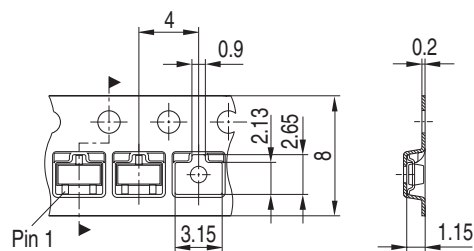

Package Outline

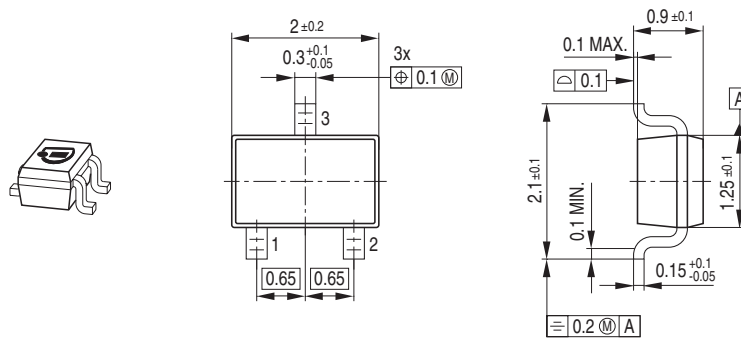

Foot Print



Marking Layout (Example)



Standard Packing

Reel  $\varnothing$ 180 mm = 3.000 Pieces/Reel  
 Reel  $\varnothing$ 330 mm = 10.000 Pieces/Reel

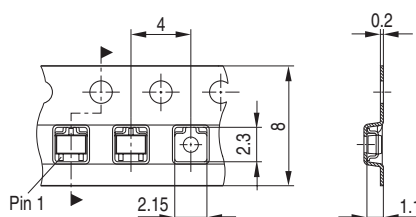

**Edition 2009-11-16**

**Published by  
Infineon Technologies AG  
81726 Munich, Germany**

**© 2009 Infineon Technologies AG  
All Rights Reserved.**

### **Legal Disclaimer**

The information given in this document shall in no event be regarded as a guarantee of conditions or characteristics. With respect to any examples or hints given herein, any typical values stated herein and/or any information regarding the application of the device, Infineon Technologies hereby disclaims any and all warranties and liabilities of any kind, including without limitation, warranties of non-infringement of intellectual property rights of any third party.

### **Information**

For further information on technology, delivery terms and conditions and prices, please contact the nearest Infineon Technologies Office ([<www.infineon.com>](http://www.infineon.com)).

### **Warnings**

Due to technical requirements, components may contain dangerous substances. For information on the types in question, please contact the nearest Infineon Technologies Office.

Infineon Technologies components may be used in life-support devices or systems only with the express written approval of Infineon Technologies, if a failure of such components can reasonably be expected to cause the failure of that life-support device or system or to affect the safety or effectiveness of that device or system. Life support devices or systems are intended to be implanted in the human body or to support and/or maintain and sustain and/or protect human life. If they fail, it is reasonable to assume that the health of the user or other persons may be endangered.

## X-ON Electronics

Largest Supplier of Electrical and Electronic Components

*Click to view similar products for [Bipolar Transistors - BJT category](#):*

*Click to view products by [Infineon manufacturer](#):*

Other Similar products are found below :

[619691C](#) [MCH4017-TL-H](#) [BC546/116](#) [BC557/116](#) [BSW67A](#) [NTE158](#) [NTE187A](#) [NTE195A](#) [NTE2302](#) [NTE2330](#) [NTE63](#) [C4460](#)  
[2SA1419T-TD-H](#) [2SA1721-O\(TE85L,F\)](#) [2SA2126-E](#) [2SB1204S-TL-E](#) [2SC5488A-TL-H](#) [2SD2150T100R](#) [SP000011176](#) [FMMTA92QTA](#)  
[2N2369ADCSM](#) [2N5769](#) [2SC2412KT146S](#) [2SC5490A-TL-H](#) [2SD1816S-TL-E](#) [2SD1816T-TL-E](#) [CMXT2207 TR](#) [CPH6501-TL-E](#)  
[MCH4021-TL-E](#) [US6T6TR](#) [732314D](#) [CMXT3906 TR](#) [CPH3121-TL-E](#) [CPH6021-TL-H](#) [873787E](#) [UMX21NTR](#) [EMT2T2R](#) [MCH6102-TL-E](#)  
[FP204-TL-E](#) [NJL0302DG](#) [2N3583](#) [2SA1434-TB-E](#) [2SC3143-4-TB-E](#) [2SD1621S-TD-E](#) [NTE103](#) [30A02MH-TL-E](#) [NSV40301MZ4T1G](#)  
[NTE101](#) [NTE13](#) [NTE15](#)