

BCR602 hot plug IC with dimming

60 V linear LED controller IC for dimmable LED applications with ripple suppression, overtemperature and hot plug protection

Features

- Supply voltage 8 V to 60 V,
- Supports use of NPN bipolar transistors and NMOS MOSFETS,
- AC supply voltage ripple suppression,
- Dimming at pin *MFIO*
 - 3% analog dimming of LED current by resistor R_{set} or DC voltage,
 - 1% PWM dimming of LED current by PWM signals,
- R_{set} functionality at pin *MFIO*,
- LED current precision $\pm 3\%$.



Protection features

- Hot plug protection,
- Overtemperature protection.

Target applications

- LED light engines/modules,
- LED replacement lamps.

Advantages with respect to discrete solutions

- Low BOM count,
- Lower assembly cost,
- Smaller form factor,
- Higher reliability due to less parts and soldering joints.

Product validation

Qualified for industrial applications according to the relevant tests of JEDEC47/20/22.

Device information

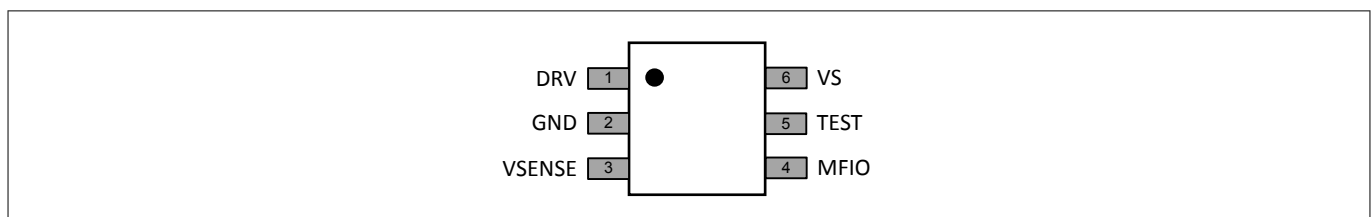

Figure 1 Pin configuration

Description

Table 1 Part information

Type	Package	Configuration	Marking code
60V Linear Current Control Chip BCR602	PG-SOT23-6	n.a.	602

Description

BCR602 is a linear LED controller IC regulating the LED current by means of an external driver transistor. BCR602 supports use of NPN bipolar transistors and NMOSFETs to cover a wide LED current and power range up to several hundred mA. The LED current is fully scalable by dimensioning an external current sense resistor. BCR602 suppresses the voltage ripple of the power supply driving a constant LED current for better light quality. The LED current can be dimmed by resistors as well as analog or digital PWM voltages connected to the Multi Function Input Output (MFIO) pin. The embedded hot plug protection allows plug in and plug out of any LED load during operation.

The overtemperature protection will dim the LED current if the BCR602 junction temperature threshold is exceeded. In this case the LED current will be reduced to 30% of the nominal current. Once the junction temperature drops below the temperature hysteresis nominal LED current is resumed.

The BCR602 is a perfect fit for LED applications by combining small form factor with low cost. Through its higher integration, BOM savings and ensuring long lifetime of LEDs, this controller has many advantages compared to discrete solutions.

Table of contents

	Features	1
	Protection features	1
	Target applications	1
	Advantages with respect to discrete solutions	1
	Product validation	1
	Device information	1
	Description	2
	Table of contents	3
1	Pin configuration	4
2	Functional description	5
3	Thermal characteristics	7
4	Absolute maximum ratings	8
5	Operating conditions	9
6	Electrical characteristics	10
7	Package information	13
8	References	14
	Revision history	14
	Disclaimer	15

Pin configuration

1 Pin configuration

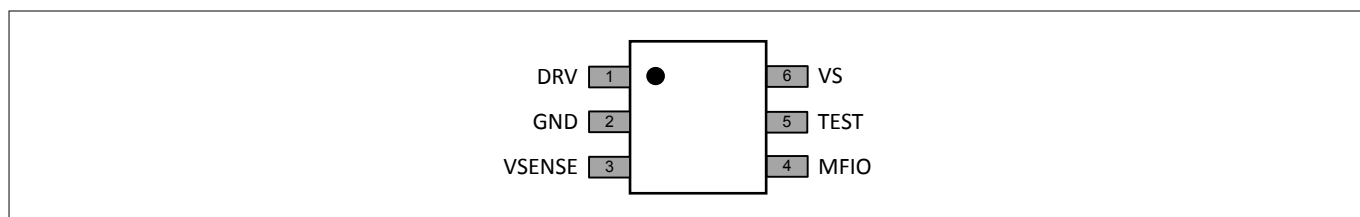

Figure 2 Pin configuration

Table 2 Pin configuration

Pin no.	Pin name	Pin type	Function
1	<i>DRV</i>	Output	Driver output to control base or gate of the external transistor
2	<i>GND</i>	GND	IC ground
3	<i>VSENSE</i>	Input	Measurement of V_{sense} voltage
4	<i>MFIO</i>	Input	Multifunctional IO for resistive (via external R_{set}), DC voltage and PWM voltage dimming
5	<i>TEST</i>	Output	For test purpose, it must not be directly connected to ground. It is recommended to leave <i>TEST</i> pin open or attach a resistor to ground > 1 M Ω .
6	<i>VS</i>	Input	Supply voltage

Functional description

2 Functional description

Typical application circuit

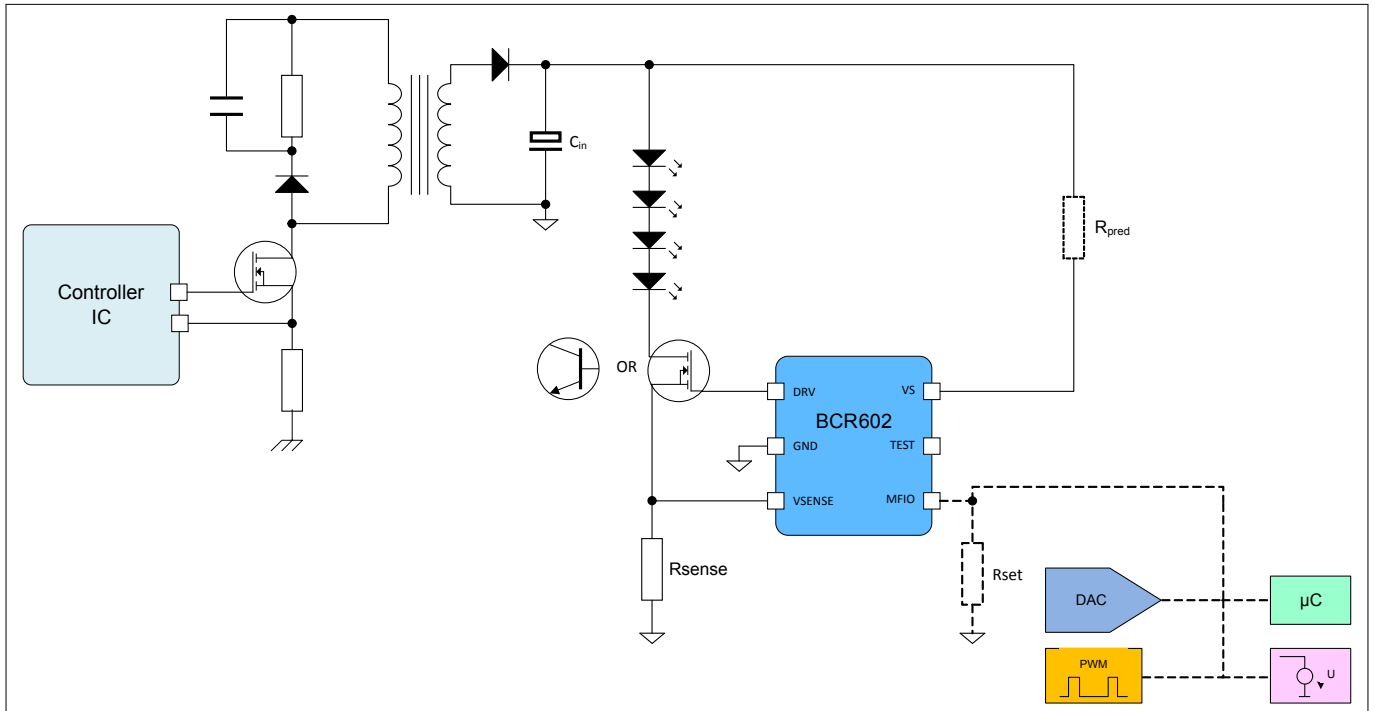

Figure 3 Typical application circuit

Application hints

1. External driver transistors
BCR602 is able to drive NPN transistors as well as NMOSFETs. NPN transistors can be used for LED currents up to several 100 mA while NMOSFETs are preferable for high LED currents. The smaller current using BJTs is caused by the DC current gain value h_{FE} value of the used BJT. E.g. a typical h_{FE} of 75 limits the application to a maximum below 750 mA.
2. Supply voltage of BCR602
To drive higher output currents into an external NPN driver transistor it might be necessary to limit the supply voltage of BCR602 significantly below 60 V to reduce power dissipation inside the IC. This can be achieved either by adding a series resistor (R_{pred}) between supply voltage and VS pin of BCR602 or by operating BCR602 by an auxiliary winding of the power supply providing a lower IC supply voltage as e.g. 8 V or higher.

Dimming mechanism

Application MFIO input signal can be a DC voltage or a pulse width modulated digital signal for dimming of the LED current.

1. Pure DC dimming: input voltage V_{MFIO} at pin MFIO. Continuous dimming from 3% dimming level up to 100% is embedded into a 100% ceiling plateau and an hysteresis range to off. Static dimming to a fixed value can be done via the resistor R_{set} .

Functional description

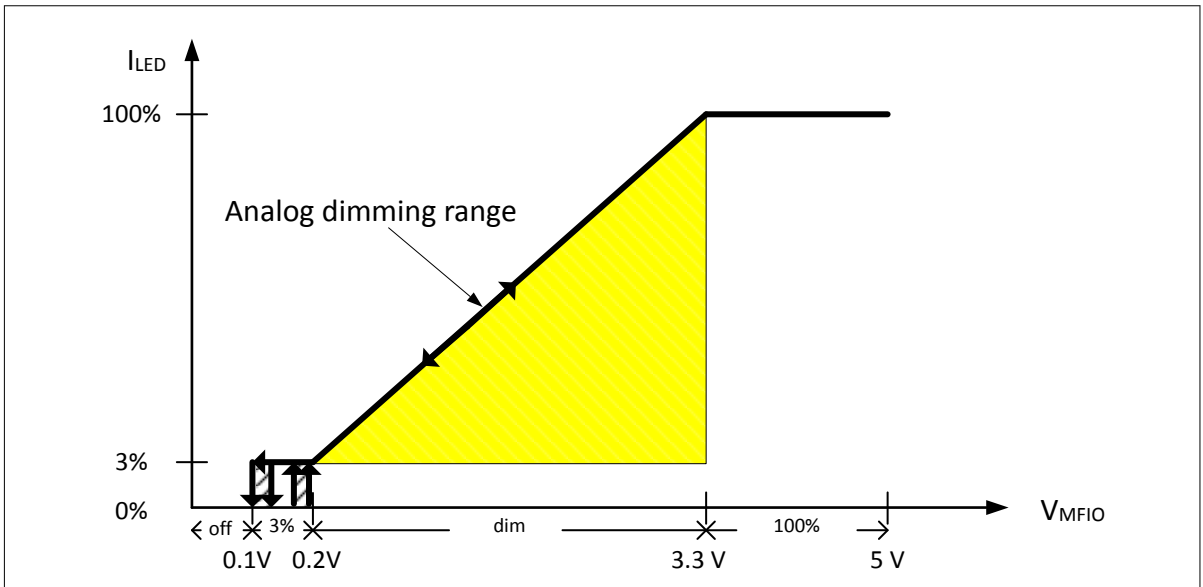

Figure 4 DC dimming

2. Pure PWM dimming: The PWM duty cycle at pin MFIO defines the dimming level. The PWM voltage amplitude corresponding to LED on must be in the voltage range specified by $V_{MFIO, 100\%}$ and PWM voltage amplitude corresponding to LED off must be in the voltage range specified by $V_{MFIO, off}$. The LED current is PWM modulated according to the PWM input signal.
3. For resistive dimming using R_{set} and internal MFIO current, the internal pull-down has to be taken into account. For proper dimensioning refer to Figure 5.

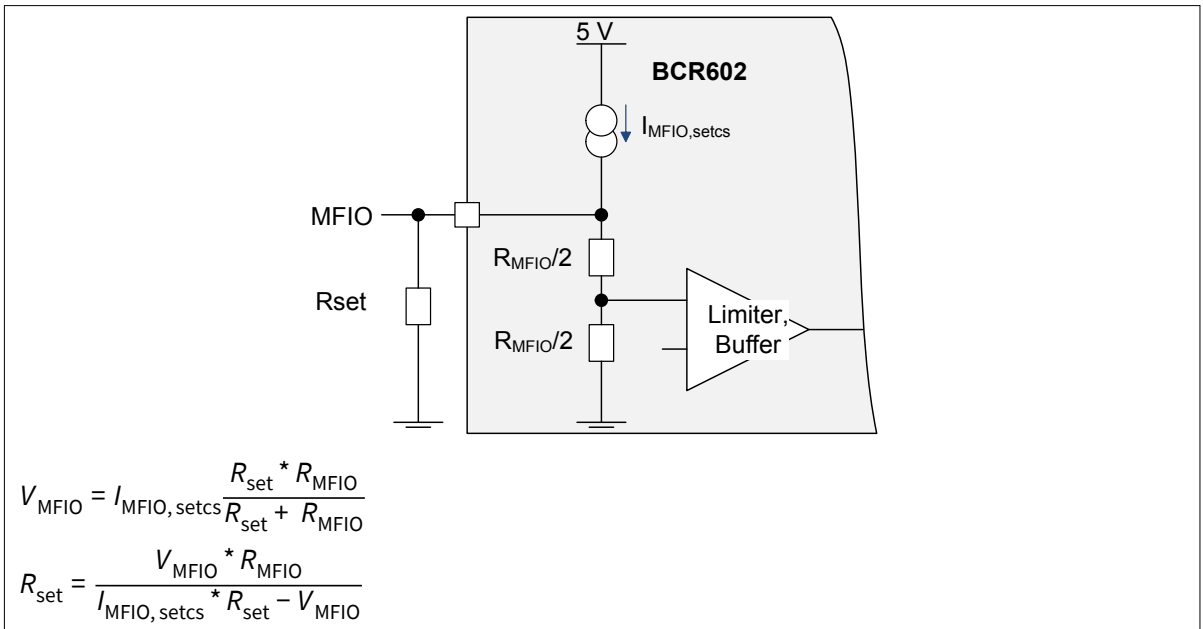

Figure 5 R_{set} dimensioning for resistor dimming

- $R_{MFIO, typical} = 285 \text{ k}\Omega$,
- $I_{MFIO, setcs, typical} = 20 \text{ }\mu\text{A}$.

Thermal characteristics

3 Thermal characteristics

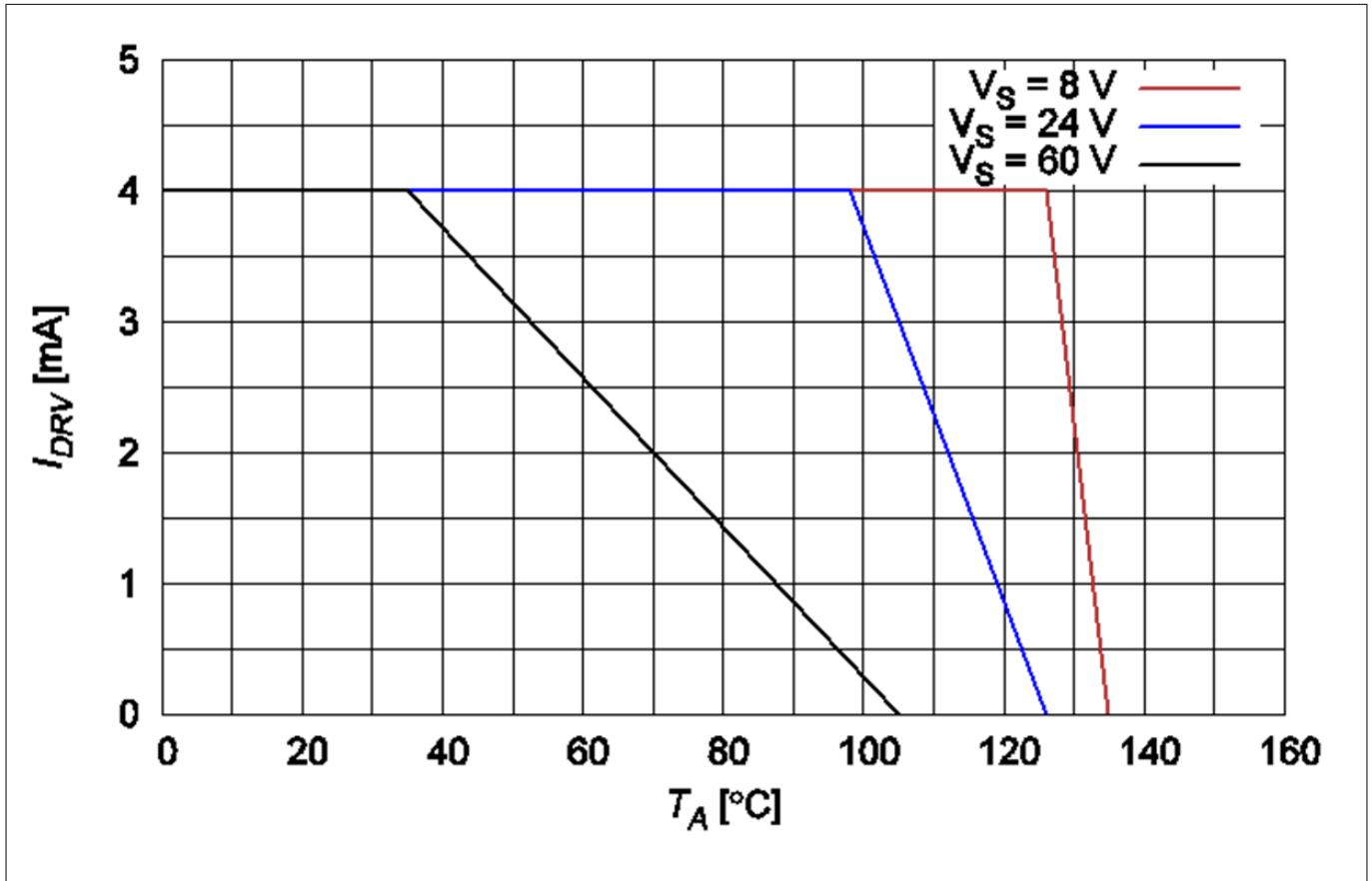

Figure 6 Maximum permitted effective output source current out of pin DRV into external driver transistor for a design example of 4 mA DC driver

The maximum permitted effective driver source current shown in [Figure 6](#) can be calculated by following equation:

$$I_{DRV} = \frac{\frac{T_{OTP, on, min} - T_A}{R_{thJA}} - V_S \cdot I_S}{V_S} = \frac{T_{OTP, on, min} - T_A}{V_S \cdot R_{thJA}} - I_S$$

The equation considers the power dissipation caused by the current consumption of the IC itself. If the driver current exceeds the calculated threshold the lower spec limit of the overtemperature protection will be exceeded and OTP might be triggered.

$T_{OTP, on, min}$ The lower spec limit of the overtemperature protection threshold should not be exceeded to avoid triggering the OTP.

Absolute maximum ratings

4 Absolute maximum ratings

Table 3 Absolute maximum ratings

Parameter	Symbol	Values			Unit	Note or test condition
		Min.	Typ.	Max.		
Junction temperature	T_J	-40	–	160	°C	–
Supply voltage	V_S	0	–	65	V	–
Input voltage at pin <i>MFIO</i>	V_{MFIO}	0	–	5.0	V	–
Input voltage at pin <i>VSENSE</i>	V_{sense}	0	–	3.6	V	–
Power dissipation	P_{tot}	–	–	360	mW	$V_S = 60\text{ V}$, $I_S = 2\text{ mA}$, $I_{DRV} = -4\text{ mA}$
ESD robustness	$V_{ESD,HBM}$	–	–	2	kV	HBMacc. to JEDEC JS-001
	$V_{ESD,CDM}$	–	–	500	V	CDM acc. to JEDEC JS-002

Attention: *Stresses above the maximum values listed here may cause permanent damage to the device. Exposure to absolute maximum rating conditions for extended periods may affect device reliability. Maximum ratings are absolute ratings. Exceeding only one of these values may cause irreversible damage to the integrated circuit.*

Table 4 Maximum thermal resistance

Parameter	Symbol	Values			Unit	Note or test condition
		Min.	Typ.	Max.		
Thermal resistance junction to ambient	R_{thJA}	–	–	290	K/W	JEDEC 1s0p (JESD 51-3) footprint w/o extra cooling area
	$R_{thJA,100}$	–	–	200	K/W	JEDEC 1s0p (JESD 51-3) with 100 mm ² cooling area
	$R_{thJA,300}$	–	–	180	K/W	JEDEC 1s0p (JESD 51-3) with 300 mm ² cooling area

Operating conditions**5 Operating conditions****Table 5 Operating conditions**

Parameter	Symbol	Values			Unit	Note or test condition
		Min.	Typ.	Max.		
Junction temperature	T_J	-40	-	160	°C	-
Supply voltage	V_S	0	-	60	V	-

Electrical characteristics

6 Electrical characteristics

Note: All parameters are measured at $T_A = 25^\circ\text{C}$, $V_S = 45\text{ V}$ unless otherwise specified.

Note: $I_{\text{LED,target}}$ current is the undimmed current at a V_{SENSE} voltage drop of 400 mV typical.

Table 6 DC characteristics

Parameter	Symbol	Values			Unit	Note or test condition
		Min.	Typ.	Max.		
IC system						
Supply voltage	V_S	8	–	60	V	Operational supply voltage range
Supply voltage brownin	$V_{S,bi}$	–	–	8	V	–
Supply voltage brownout	$V_{S,bo}$	6.7	–	–	V	–
Supply current	I_S	-2.2	–	–	mA	$I_{\text{DRV, source}} = 0\text{ A}$
Sense voltage	V_{sense}	388	400	412	mV	Closed loop reference voltage of pin V_{SENSE} , $I_{\text{LED}} = V_{\text{sense}} / R_{\text{sense}}$
LED current accuracy						
LED current accuracy	$I_{\text{LED, acc}} / I_{\text{LED, acc, target}}$	-3	–	3	%	Closed loop LED current accuracy without dimming at $V_{\text{MFIO}} = 3.3\text{ V}$
Driver						
Driver source current capability, DC	$I_{\text{DRV, source}}$	10	–	–	mA	Source current range of pin DRV to drive NPN base/NMOS gate
Driver sink current capability, DC	$I_{\text{DRV, sink}}$	–	–	-10	mA	Sink current range of pin DRV to discharge NPN base/NMOS gate
Driver source voltage	V_{DRV}	4.5	5	5.5	V	Max. output voltage of pin DRV
Dimming analog						
MFIO turn-off range	$V_{\text{MFIO, off}}$	0	–	0.1	V	Threshold for analog dimming to off
MFIO turn-on range	$V_{\text{MFIO, on}}$	0.17	–	0.195	V	Threshold for analog dimming to on
MFIO full current range	$V_{\text{MFIO, 100\%}}$	3.3	–	5	V	MFIO range always at 100% I_{LED}
MFIO output source current	$I_{\text{MFIO, setcs}}$	18	20	22	μA	For $R_{\text{SET}} < 10\text{ k}\Omega$, in parallel internal pull-down R_{MFIO} connected, refer to Figure 5
MFIO output voltage	$V_{\text{MFIO, setcs}}$	–	4.2	–	V	MFIO output voltage at MFIO open

Electrical characteristics
Table 6 DC characteristics (continued)

Parameter	Symbol	Values			Unit	Note or test condition
		Min.	Typ.	Max.		
MFIO pull-down resistor	R_{MFIO}	228	285	342	k Ω	Internal pull-down resistor at pin <i>MFIO</i>
MFIO dimming range	$V_{MFIO, dim}$	0.2	–	3.3	V	Analog dimming range of the LED current
Analog LED dimming	$I_{LEDmin, ana} / I_{LEDmin, target}$	–	3	–	%	Minimum dimming LED current level at $MFIO_{dim} = 0.15 V$
LED current chip to chip variation at selected dimming level		-20	–	20	%	Max variation at minimum MFIO dimming level
		-10		10		Max variation for dimming level higher than minimum

Dimming PWM¹⁾

MFIO PWM frequency	f_{PWM}	–	–	3.5	kHz	Maximum supported PWM frequency at pin <i>MFIO</i> , external switch $Q_g = 8.7 nC$
Minimum PWM duty cycle	$I_{LEDmin, PWM} / I_{LED, target}$	–	1	–	%	Minimum LED current dimming ratio by a PWM signal connected to pin <i>MFIO</i> , external switch $Q_g = 8.7 nC$
Minimum pulse width	$t_{duty, on}$	2.9	–	–	μs	Minimum LED PWM digital pulse width between 0 V and 3.3 V, external switch $Q_g = 8.7 nC$

Overtemperature protection OTP

Overtemperature protection threshold, turn on	$T_{OTP, on}$	140	–	155	$^{\circ}C$	Junction threshold temperature to trigger overtemperature protection in standby, $I_{DRV} = 0 mA$ and $VS = 45 V$
Overtemperature protection threshold, turn off	$T_{OTP, off}$	120	–	135	$^{\circ}C$	Junction threshold temperature to exit overtemperature protection in standby, $I_{DRV} = 0 mA$ and $VS = 45 V$

¹ Tested at 0.5 kHz and 3.5 kHz.

Electrical characteristics
Table 6 DC characteristics (continued)

Parameter	Symbol	Values			Unit	Note or test condition
		Min.	Typ.	Max.		
Sense voltage in OTP case	$V_{\text{sense, OTP}} / V_{\text{sense, target}}$	–	30	–	%	Reduction factor at pin <i>VSENSE</i> (nominal 400 mV) if OTP has been triggered, $I_{\text{LED, OTP}} = V_{\text{sense, OTP}} / R_{\text{sense}}$
Overtemperature protection hysteresis	$T_{\text{OTP, Hys}}$	–	20	–	°C	–
Hot plug						
Hot plug <i>VSENSE</i> threshold	$V_{\text{sense, HP}}$	–	8	–	mV	<i>VSENSE</i> level at which hot plug event is detected

Package information

7 Package information

Note: Dimensions in mm.

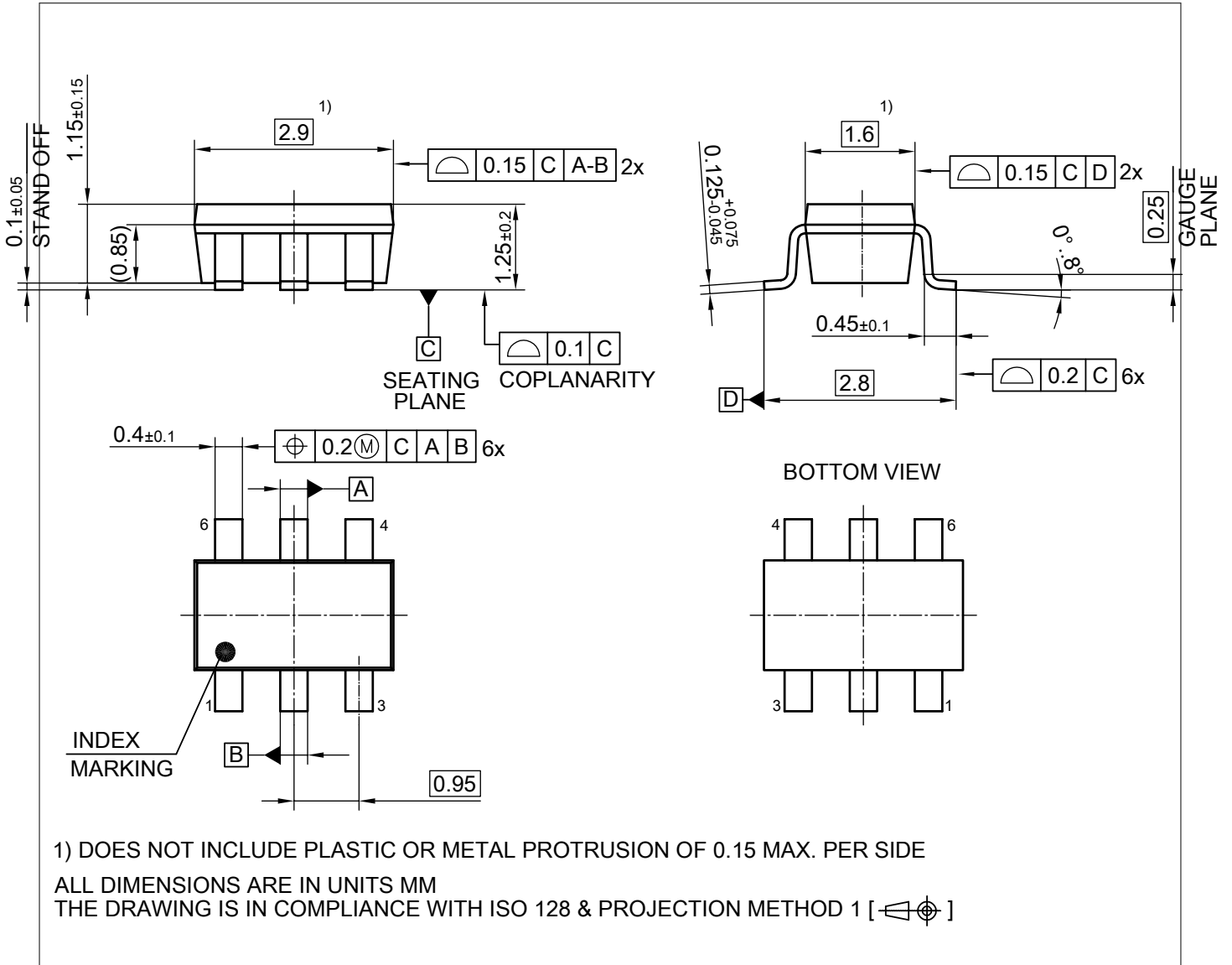

Figure 7 Package outline PG-SOT23-6

References

8 References

Revision history

Document version	Date of release	Description of changes
v1.0	2018-11-23	<ul style="list-style-type: none">Public release
v1.1	2018-12-03	<ul style="list-style-type: none">Parameter update

Trademarks

All referenced product or service names and trademarks are the property of their respective owners.

Edition 2018-12-3

Published by
Infineon Technologies AG
81726 Munich, Germany

© 2018 Infineon Technologies AG
All Rights Reserved.

Do you have a question about any aspect of this document?

Email: erratum@infineon.com

Document reference
IFX-rjb1519293082418

IMPORTANT NOTICE

The information given in this document shall in no event be regarded as a guarantee of conditions or characteristics ("Beschaffheitsgarantie").

With respect to any examples, hints or any typical values stated herein and/or any information regarding the application of the product, Infineon Technologies hereby disclaims any and all warranties and liabilities of any kind, including without limitation warranties of non-infringement of intellectual property rights of any third party.

In addition, any information given in this document is subject to customer's compliance with its obligations stated in this document and any applicable legal requirements, norms and standards concerning customer's products and any use of the product of Infineon Technologies in customer's applications.

The data contained in this document is exclusively intended for technically trained staff. It is the responsibility of customer's technical departments to evaluate the suitability of the product for the intended application and the completeness of the product information given in this document with respect to such application.

WARNINGS

Due to technical requirements products may contain dangerous substances. For information on the types in question please contact your nearest Infineon Technologies office.

Except as otherwise explicitly approved by Infineon Technologies in a written document signed by authorized representatives of Infineon Technologies, Infineon Technologies' products may not be used in any applications where a failure of the product or any consequences of the use thereof can reasonably be expected to result in personal injury

X-ON Electronics

Largest Supplier of Electrical and Electronic Components

Click to view similar products for [LED Lighting Drivers](#) category:

Click to view products by [Infineon](#) manufacturer:

Other Similar products are found below :

[LV5235V-MPB-H](#) [AP5726WUG-7](#) [IS31BL3228B-UTLS2-TR](#) [IS31BL3506B-TTLS2-TR](#) [AP5725FDCG-7](#) [AP5726FDCG-7](#) [SLG7NT4082V](#)
[SLG7NT4082VTR](#) [AP5725WUG-7](#) [BD1604MVV-E2](#) [MAX16840ATB+](#) [CAT4004BHU2-GT3](#) [TLE4242EJ](#) [IS31LT3172-GRLS4-TR](#)
[IS32LT3174-GRLA3-TR](#) [ZXLD1374QESTTC](#) [NCV78825DQ0R2G](#) [MP4425AGQB-P](#) [MP3367GR-P](#) [MPQ3369GR-P](#) [MPQ7220GF-AEC1-P](#)
[MP3362GJ-Z](#) [DIO5662ST6](#) [IS31BL3508A-TTLS2-TR](#) [DIO5661TST6](#) [NJW4617DL3-TE1](#) [BD2802GU-E2](#) [BD6583MUV-E2](#)
[NCV7693DB0R2G](#) [LV52207NXA-VH](#) [NCL30076AADR2G](#) [NCL30486B2DR2G](#) [NCL30488B4DR2G](#) [NCV78763MW4AR2G](#)
[BD18353EFV-ME2](#) [A6217KLJTR-T](#) [LT3761EMSE#TRPBF](#) [TLD2132-1EP](#) [TLD2331-3EP](#) [MPM6010GQV-AEC1-Z](#) [MPQ4425MGQB-](#)
[AEC1-Z](#) [MPQ3326GR-AEC1-Z](#) [MPQ7230GLE-AEC1-Z](#) [MP2341GTL-Z](#) [BCR602](#) [IS31FL3236-TQLS2-TR](#) [TLD700216ESXUMA1](#)
[LM3405AXMYX/NOPB](#) [LM36273YFFR](#) [MP46885DN-LF-Z](#)