

# BGA428

Gain and PCS Low Noise Amplifier

RF & Protection Devices



**Edition 2011-09-02**

**Published by Infineon Technologies AG,  
81726 München, Germany**

**© Infineon Technologies AG 2011.  
All Rights Reserved.**

**Attention please!**

The information herein is given to describe certain components and shall not be considered as a guarantee of characteristics.

Terms of delivery and rights to technical change reserved.

We hereby disclaim any and all warranties, including but not limited to warranties of non-infringement, regarding circuits, descriptions and charts stated herein.

**Information**

For further information on technology, delivery terms and conditions and prices please contact your nearest Infineon Technologies Office ([www.infineon.com](http://www.infineon.com)).

**Warnings**

Due to technical requirements components may contain dangerous substances. For information on the types in question please contact your nearest Infineon Technologies Office.

Infineon Technologies Components may only be used in life-support devices or systems with the express written approval of Infineon Technologies, if a failure of such components can reasonably be expected to cause the failure of that life-support device or system, or to affect the safety or effectiveness of that device or system. Life support devices or systems are intended to be implanted in the human body, or to support and/or maintain and sustain and/or protect human life. If they fail, it is reasonable to assume that the health of the user or other persons may be endangered.

---

**BGA428, Gain and PCS Low Noise Amplifier****Revision History: 2011-09-02, Rev. 2.3****Previous Version: 2007-11-06, Rev. 2.3**

Page	Subjects (major changes since last revision)
6	Correction of typing error in <a href="#">Table 3</a> , ( $IIP_3$ is -9 dBm)

**Trademarks**SIEGET<sup>®</sup> is a registered trademark of Infineon Technologies AG.

# 1 Silicon Germanium Broadband MMIC Amplifier

## Feature

- High gain,  $G_{MA} = 20$  dB at 1.8 GHz
- Low noise figure,  $NF = 1.4$  dB at 1.8 GHz
- Prematched
- Ideal for GSM, DCS1800, PCS1900
- Open collector output
- Typical supply voltage: 2.4 - 3 V
- SIEGET<sup>®</sup>-45 technology
- Pb-free (RoHS compliant) package

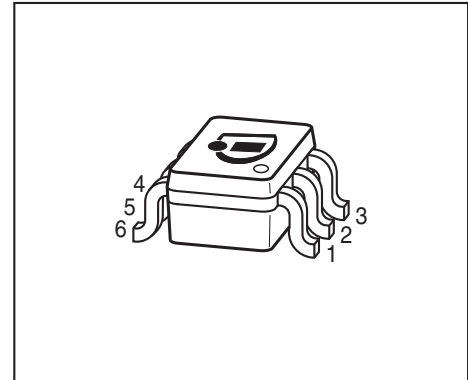

SOT363

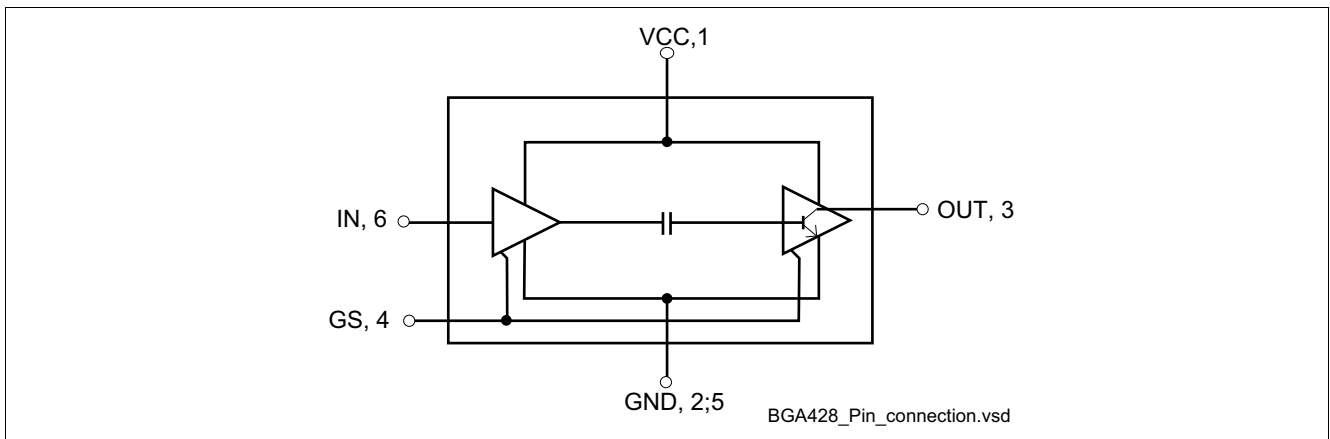

Figure 1 Pin connection

## Description

BGA428 is a high gain, low noise amplifier.

Type	Package	Marking
BGA428	SOT363	PGs

Note: **ESD**: Electrostatic discharge sensitive device, observe handling precaution

**Maximum Ratings**
**Table 1 Maximum ratings**

Parameter	Symbol	Limit Value	Unit
Device voltage	$V_{CC}$	4	V
Voltage at pin Out	$V_{out}$	4	V
Voltage at pin GS	$V_{GS}$	3.5	V
Current into pin In	$I_{in}$	0.5	mA
Total device current <sup>1)</sup>	$I_{tot}$	12	mA
Input power <sup>2)</sup>	$P_{in}$	8	dBm
Total power dissipation, $T_S < 125\text{ °C}$ <sup>3)</sup>	$P_{tot}$	50	mW
Junction temperature	$T_J$	150	°C
Operating temperature range	$T_{OP}$	-40... 85	°C
Storage temperature range	$T_{STG}$	-65... 150	°C

1)  $I_{tot}$  = Current into Out + Current into  $V_{CC}$

2) Valid for:

a)  $Z_L = 50\ \Omega$ ,  $Z_S = 50\ \Omega$ ,  $V_{CC} = 2.7\text{ V}$ ,  $V_{out} = 2.7\text{ V}$ ,  $V_{GS} = 0.0\text{ V}$ ,  $GND = 0.0\text{ V}$

b)  $Z_L = 50\ \Omega$ ,  $Z_S = 50\ \Omega$ ,  $V_{CC} = 0.0\text{ V}$ ,  $V_{out} = 0.0\text{ V}$ ,  $V_{GS} = 2.7\text{ V}$ ,  $GND = 0.0\text{ V}$

3)  $T_S$  is measured on the ground lead at the soldering point

*Note: All Voltages refer to GND-Node*

**Thermal resistance**
**Table 2 Thermal resistance**

Parameter	Symbol	Value	Unit
Junction - soldering point <sup>1)</sup>	$R_{thJS}$	220	K/W

1) For calculation of  $R_{thJA}$  please refer to Application Note Thermal Resistance

## 2 Electrical Characteristics

2.1 Electrical characteristics at  $T_A = 25\text{ }^\circ\text{C}$  (measured in test circuit specified in **Figure 2**),  $V_{CC} = 2.7\text{ V}$ , Frequency = 1.8 GHz, unless otherwise specified

**Table 3** Electrical Characteristics

Parameter	Symbol	Values			Unit	Note / Test Condition
		Min.	Typ.	Max.		
Maximum available power gain	$G_{MA}$		20		dB	
Noise figure ( $Z_S = 50\ \Omega$ )	$NF$		1.4		dB	
Input power at 1 dB gain compression	$P_{-1dB}$		-19		dBm	
Input third order intercept point	$IIP_3$		-9		dBm	
Total device current	$I_{tot}$		8.2		mA	
Insertion loss in gain-step-mode	$L_{GS}$		13.5		dB	$V_{CC} = 0.0\text{ V}$ , $V_{CTRL} = 2.7\text{ V}$ , $R_{CRRL} = 3\text{ k}\Omega$

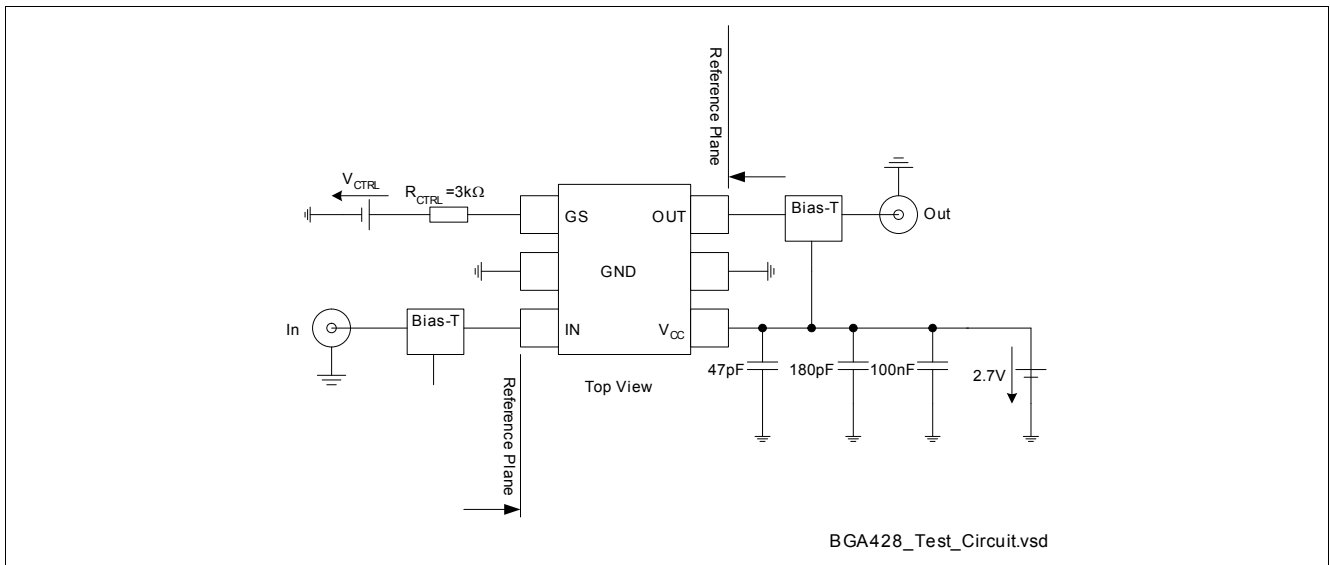

**Figure 2** Test Circuit for Electrical Characteristics and S-Parameter

**Table 4 S-Parameter at 2.7 V (see Electrical Characteristics for conditions)**

Frequency [GHz]	S11 Mag	S11 Ang	S21 Mag	S21 Ang	S12 Mag	S12 Ang	S22 Mag	S22 Ang
0.100	0.6756	-31.7	58.775	-19.6	0.0005	153.5	0.9491	-3.9
0.200	0.5936	-53.6	47.806	-43.1	0.0014	138.4	0.9327	-6.3
0.300	0.5150	-71.4	39.232	-59.5	0.0021	119.0	0.9174	-8.3
0.400	0.4587	-86.6	31.740	-71.8	0.0028	104.9	0.9035	-10.3
0.600	0.4004	-110.7	23.868	-89.6	0.0042	105.9	0.8807	-14.0
0.800	0.3743	-129.1	18.509	-103.2	0.0063	94.3	0.8593	-17.7
1.000	0.3743	-143.0	14.825	-114.5	0.0082	92.4	0.8352	-21.4
1.200	0.3816	-154.5	12.288	-124.7	0.0093	87.2	0.8116	-25.1
1.400	0.3922	-164.4	10.353	-134.2	0.0110	85.3	0.7865	-28.7
1.600	0.4086	-172.4	8.879	-143.2	0.0132	79.4	0.7597	-32.2
1.800	0.4265	-178.9	7.732	-151.4	0.0141	79.4	0.7309	-36.0
1.900	0.4314	-178.8	7.214	-155.2	0.0146	76.1	0.7199	-37.5
2.000	0.4371	176.1	6.771	-159.1	0.0150	77.0	0.7097	-39.1
2.200	0.4505	171.2	5.976	-166.6	0.0169	75.2	0.6791	-42.3
2.400	0.4640	167.2	5.298	-173.5	0.0181	73.2	0.6593	-45.6
3.000	0.4935	155.9	3.935	167.0	0.0217	68.3	0.5925	-53.3
4.000	0.5181	141.2	2.605	139.2	0.0282	65.1	0.5284	-64.9
5.000	0.5202	126.9	1.911	113.6	0.0319	62.2	0.4829	-75.1
6.000	0.5128	110.0	1.479	89.9	0.0489	56.0	0.4323	-81.7

**2.2 Application Circuit Characteristics (measured in test circuit specified in Figure 3),  $T_A = 25\text{ }^\circ\text{C}$ ,  $V_{CC} = 2.7\text{ V}$ , Frequency = 1.85 GHz, unless otherwise specified**

**Table 5 Application Circuit Characteristics**

Parameter	Symbol	Values			Unit	Note / Test Condition
		Min.	Typ.	Max.		
Insertion power gain	$ S_{21} ^2$		19		dB	
Noise figure ( $Z_S = 50\ \Omega$ )	$NF$		1.4		dB	
Input power at 1 dB gain compression	$P_{-1dB}$		-19		dBm	
Input third order intercept point	$IIP_3$		-9		dBm	
Total device current	$I_{tot}$		8.2		mA	
Insertion loss in gain-step-mode	$L_{GS}$		13.5		dB	$V_{CC} = 0.0\text{ V}$ , $V_{CTRL} = 2.7\text{ V}$ , $R_{CRRL} = 3\text{ k}\Omega$

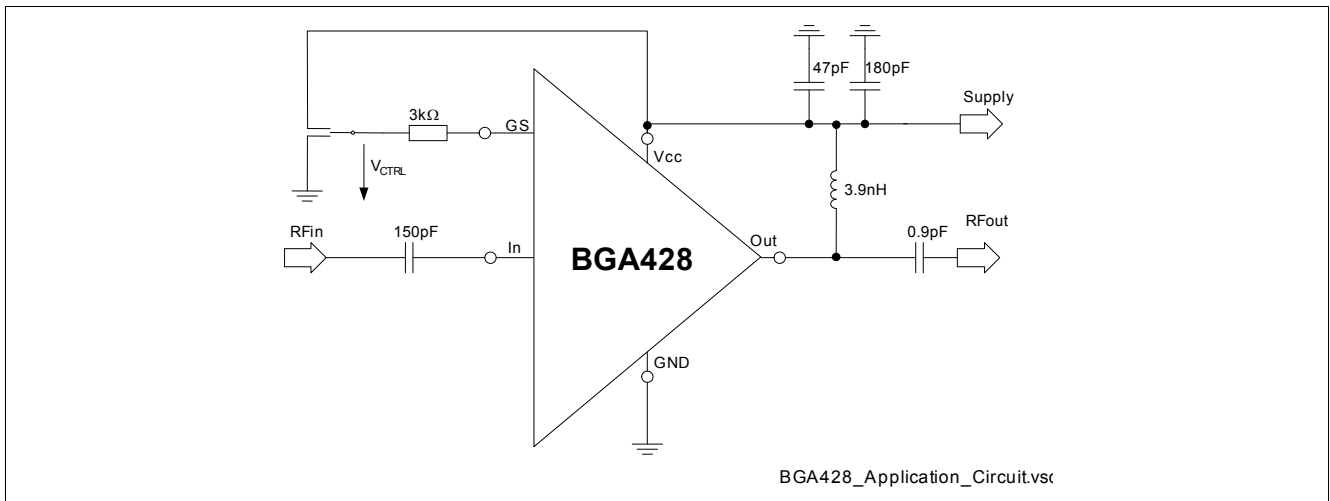

**Figure 3 Application Circuit for 1850 MHz**



### 3 Measured Parameters

Refer to the application circuit given in [Figure 3](#)

**Power Gain  $|S_{21}|^2=f(f)$**   
 $V_{CC} = 2.7V, V_{Out} = 2.7V$

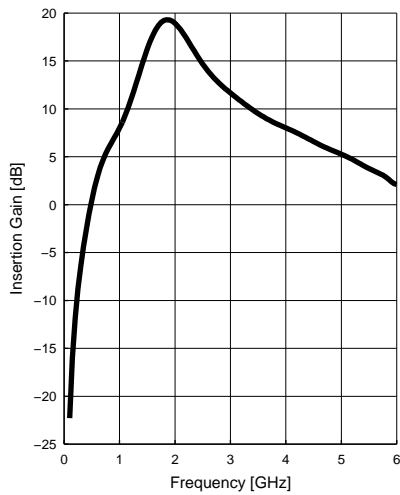

**Power Gain  $|S_{21}|^2=f(f)$**   
 $V_{CC} = 2.7V, V_{Out} = 2.7V$

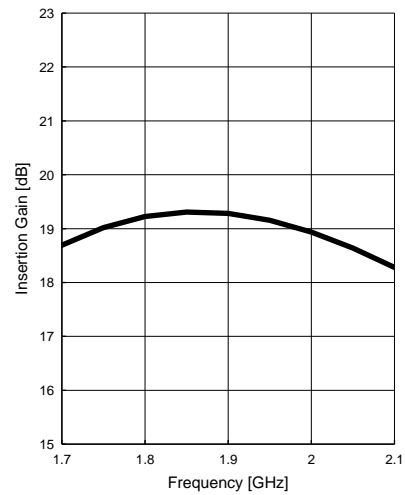

**Off-Gain  $|S_{21}|^2=f(V_{CTRL})$**   
 $V_{CC} = 0.0V, V_{Out} = 0.0V, R_{CTRL} = 2.7k\Omega$

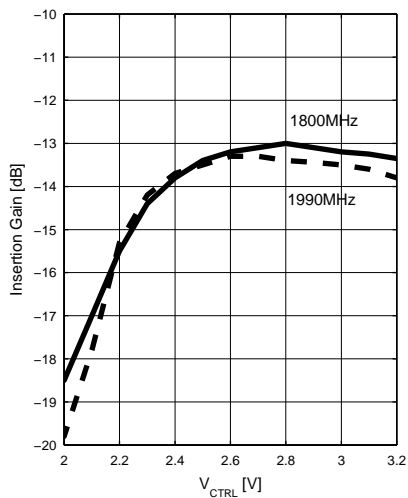

**Matching  $|S_{11}|, |S_{22}|=f(f)$**   
 $V_{CC} = 2.7V, V_{Out} = 2.7V$

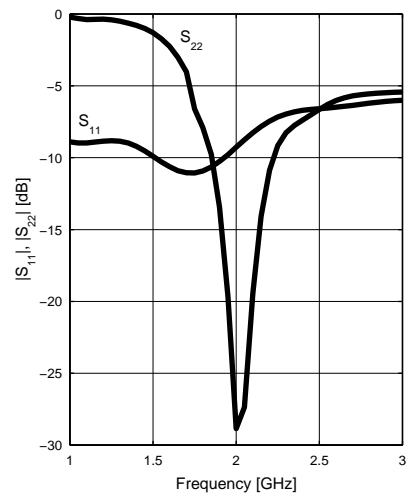

**Input Compression Point  $P_{-1dB}=f(f)$**

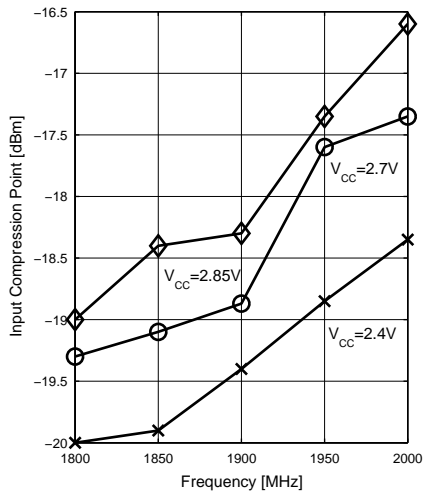

**Device Current  $I=f(\vartheta)$**

$V_{CC}=2.7V, V_{Out}=2.7V$

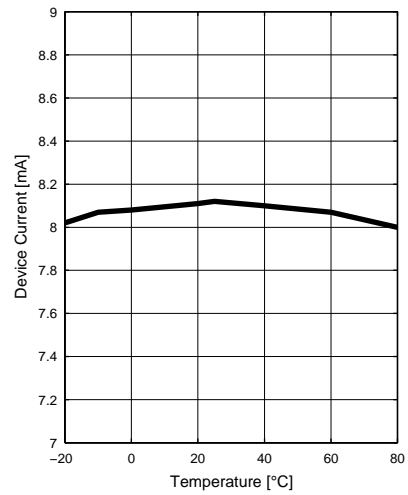

**Insertion Gain  $|S_{21}|^2=f(\vartheta)$**

$V_{CC}=2.7V, V_{Out}=2.7V$

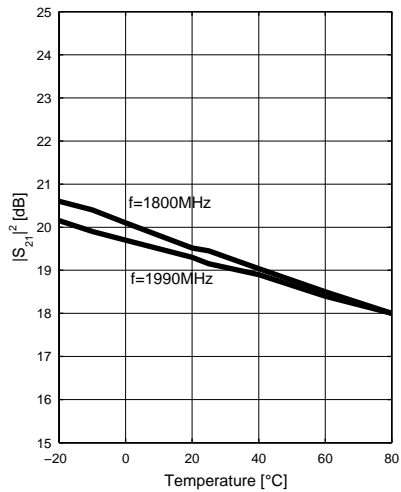

## 4 Package Information

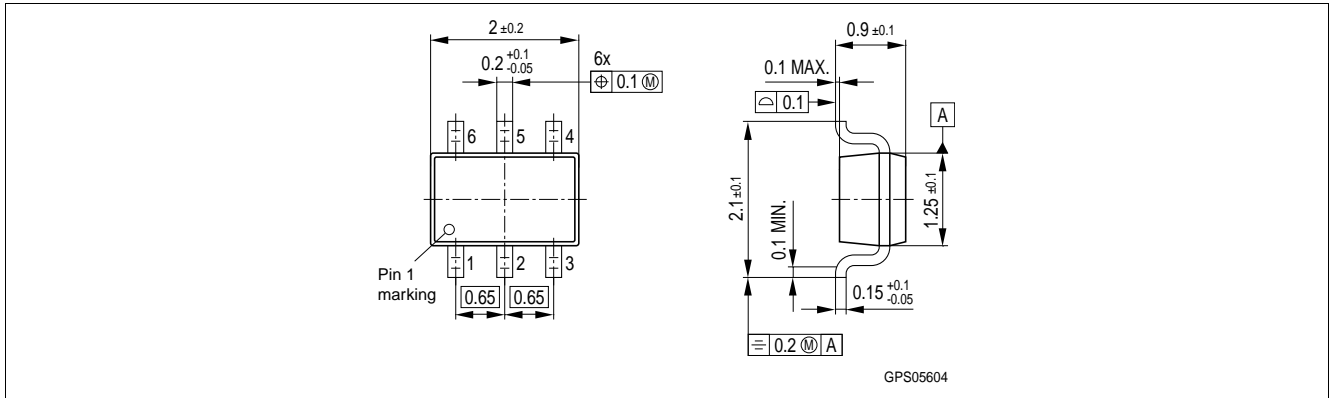

Figure 4 Package Outline SOT363

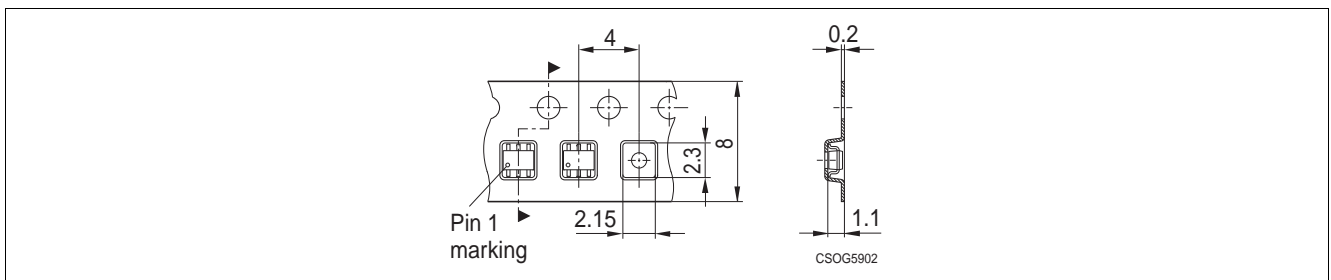

Figure 5 Tape for SOT363

## X-ON Electronics

Largest Supplier of Electrical and Electronic Components

*Click to view similar products for [infineon](#) manufacturer:*

Other Similar products are found below :

[TLE6209R](#) [BTS442E2E3062ABUMA1](#) [EVALM113023645ATOBO1](#) [EVALM11302TOBO1](#) [FD1000R33HE3-K](#) [FD300R06KE3](#)  
[FF1200R17KE3\\_B2](#) [FF300R06KE3HOSA1](#) [FF600R12ME4P](#) [FF600R17ME4\\_B11](#) [FP25R12KT4\\_B11](#) [FS150R12KE3G](#)  
[FS600R07A2E3\\_B31](#) [FZ1600R17HP4\\_B2](#) [FZ1800R17KF4](#) [FZ2400R17HE4\\_B9](#) [FZ600R65KE3](#) [DD261N22K](#) [DF1000R17IE4](#) [BAT 165](#)  
[E6327](#) [BCR 141W H6327](#) [BCR 533 E6327](#) [BDP950H6327XTSA1](#) [BSC093N04LSGATMA1](#) [BSM50GB60DLC](#) [BSO080P03NS3EGXUMA](#)  
[BSR802NL6327HTSA1](#) [BSR92PH6327XTSA1](#) [BSS806NEH6327XTSA1](#) [BSZ086P03NS3EGATMA](#) [BTF3050TE](#) [BTM7811KAUMA1](#)  
[IPD50N04S4-08](#) [IPW60R190E6FKSA1](#) [IRPLHID2A](#) [KIT\\_TC1791\\_SK](#) [KIT\\_XMC45\\_AE4\\_002](#) [KIT\\_XMC4x\\_COM\\_ETH-001](#)  
[EVALM10565DUTOBO1](#) [EVALM113020584DUTOBO1](#) [FF300R17KE3\\_S4](#) [FF450R12ME4\\_B11](#) [FF600R17ME4](#) [T1401N42TOH](#)  
[T1500N16TOF VT](#) [T1851N60TOH](#) [T901N36TOF](#) [FS300R12KE4](#) [FS450R17KE4](#) [FZ1500R33HE3](#)