

BGA622

Silicon Germanium Wide Band Low Noise
Amplifier with 2 kV ESD Protection

Small Signal Discretes



Never stop thinking

Edition 2008-04-14

**Published by Infineon Technologies AG,
81726 München, Germany**

**© Infineon Technologies AG 2008.
All Rights Reserved.**

Attention please!

The information herein is given to describe certain components and shall not be considered as a guarantee of characteristics.

Terms of delivery and rights to technical change reserved.

We hereby disclaim any and all warranties, including but not limited to warranties of non-infringement, regarding circuits, descriptions and charts stated herein.

Information

For further information on technology, delivery terms and conditions and prices please contact your nearest Infineon Technologies Office (www.infineon.com).

Warnings

Due to technical requirements components may contain dangerous substances. For information on the types in question please contact your nearest Infineon Technologies Office.

Infineon Technologies Components may only be used in life-support devices or systems with the express written approval of Infineon Technologies, if a failure of such components can reasonably be expected to cause the failure of that life-support device or system, or to affect the safety or effectiveness of that device or system. Life support devices or systems are intended to be implanted in the human body, or to support and/or maintain and sustain and/or protect human life. If they fail, it is reasonable to assume that the health of the user or other persons may be endangered.

BGA622, Silicon Germanium Wide Band Low Noise Amplifier with 2 kV ESD Protection

Revision History: 2008-04-14, Rev. 2.2

Previous Version: 2005-11-16

Page	Subjects (major changes since last revision)
All	Document layout change

Trademarks

SIEGET[®] is a registered trademark of Infineon Technologies AG.

1 Silicon Germanium Wide Band Low Noise Amplifier with 2 kV ESD Protection

Feature

- High gain
 - $|S_{21}|^2 = 15.0$ dB at 1.575 GHz
 - $|S_{21}|^2 = 14.2$ dB at 1.9 GHz
 - $|S_{21}|^2 = 13.6$ dB at 2.14 GHz
- Low noise figure, $NF = 1.0$ dB at 1.575 GHz
- Operating frequency range 0.5 - 6 GHz
- Typical supply voltage: 2.75 V
- On/Off-Switch
- Output-match on chip, input pre-matched
- Low part count
- 70 GHz f_T - Silicon Germanium technology
- 2 kV HBM ESD protection (Pin-to-Pin)
- Pb-free (RoHS compliant) package

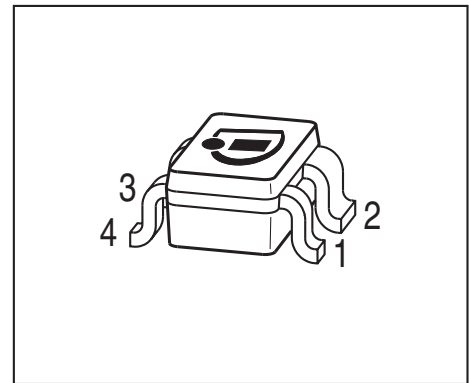

SOT343



Applications

- LNA for GSM, GPS, DCS, PCS, UMTS, Bluetooth, ISM and WLAN

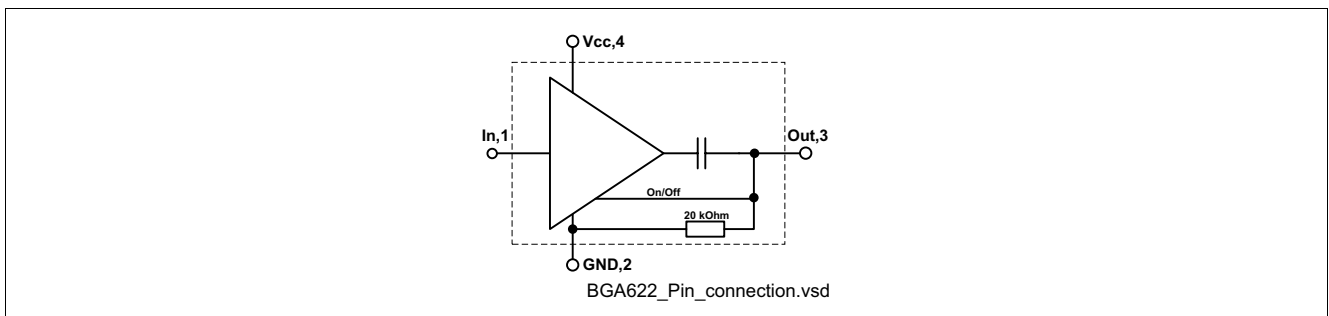

Figure 1 Pin connection

Description

The BGA622 is a wide band low noise amplifier, based on Infineon Technologies' Silicon Germanium Technology B7HF. In order to provide the LNA in a small package the out-pin is simultaneously used for RF out and On/Off switch. This functionality can be accessed using a RF-Choke at the Out pin, where a DC level of 0 V or an open switches the device on and a DC level of V_{CC} switches the device off. While the device is switched off, it provides an insertion loss of 24 dB together with a high IIP_3 up to 20 dBm.

Type	Package	Marking
BGA622	SOT343	BXs

Note: **ESD:** Electrostatic discharge sensitive device, observe handling precaution

Silicon Germanium Wide Band Low Noise Amplifier with 2 kV ESD Protection
Maximum Ratings
Table 1 Maximum ratings

Parameter	Symbol	Limit Value	Unit
Voltage at pin V_{CC}	V_{CC}	3.5	V
Voltage at pin Out	V_{out}	4	V
Current into pin In	I_{in}	0.1	mA
Current into pin Out	I_{out}	1	mA
Current into pin V_{CC}	$I_{V_{CC}}$	10	mA
RF input power	P_{in}	6	dBm
Total power dissipation, $T_S < 139\text{ °C}^{1)}$	P_{tot}	35	mW
Junction temperature	T_J	150	°C
Ambient temperature range	T_A	-65... 150	°C
Storage temperature range	T_{STG}	-65... 150	°C
ESD capability all pins (HBM: JESD22-A114)	V_{ESD}	2000	V

1) T_S is measured on the ground lead at the soldering point

Note: All Voltages refer to GND-Node

Thermal resistance
Table 2 Thermal resistance

Parameter	Symbol	Value	Unit
Junction - soldering point ¹⁾	R_{thJS}	300	K/W

1) For calculation of R_{thJA} please refer to Application Note Thermal Resistance

2 Electrical Characteristics

2.1 Electrical characteristics at $T_A = 25\text{ °C}$ (measured according to [Figure 2](#)) $V_{CC} = 2.75\text{ V}$, Frequency = 1.575 GHz, unless otherwise specified

Table 3 Electrical Characteristics

Parameter	Symbol	Values			Unit	Note / Test Condition
		Min.	Typ.	Max.		
Insertion power gain	$ S_{21} ^2$		15.0		dB	
Insertion power gain (Off-State)	$ S_{21} ^2$		-27		dB	
Input return loss (On-State)	RL_{in}		5		dB	
Output return loss (On-State)	RL_{out}		12		dB	
Noise figure ($Z_S = 50\ \Omega$)	$F_{50\Omega}$		1.00		dB	$f = 0.1\text{ GHz}$
Input third order intercept point ¹⁾ (On-State)	IIP_3		0		dBm	$\Delta f = 1\text{ MHz}$, $P_{IN} = -28\text{ dBm}$
Input third order intercept point ¹⁾ (Off - State)	IIP_3		20		dBm	$\Delta f = 1\text{ MHz}$, $P_{IN} = -8\text{ dBm}$
Input power at 1 dB gain compression	P_{-1dB}		-16.5		dBm	
Total device off current	$I_{tot-off}$	130	260	420	μA	$V_{CC} = 2.75\text{ V}$, $V_{out} = V_{CC}$
Total device on current	I_{tot-on}	4.0	5.8	7.8	mA	$V_{CC} = 2.75\text{ V}$
On / Off switch control voltage	V_{on}	0		0.8	V	$V_{CC} = 2.75\text{ V}$ ON-Mode: $V_{out} = V_{on}$
	V_{off}	2.0		3.5	V	$V_{CC} = 2.75\text{ V}$ OFF-Mode: $V_{out} = V_{off}$

1) IP_3 values depends on termination of all intermodulation frequency components. Termination used for this measurement is 50 Ω from 0.1 to 6 GHz

**2.2 Electrical characteristics at $T_A = 25\text{ }^\circ\text{C}$ (measured according to [Figure 2](#))
 $V_{CC} = 2.75\text{ V}$, Frequency = 2.14 GHz, unless otherwise specified**

Table 4 Electrical Characteristics

Parameter	Symbol	Values			Unit	Note / Test Condition
		Min.	Typ.	Max.		
Insertion power gain	$ S_{21} ^2$		13.6		dB	
Insertion power gain (Off-State)	$ S_{21} ^2$		-24		dB	
Input return loss (On-State)	RL_{in}		7		dB	
Output return loss (On-State)	RL_{out}		10		dB	
Noise figure ($Z_S = 50\ \Omega$)	$F_{50\Omega}$		1.05		dB	
Input third order intercept Point ¹⁾ (On-State)	IIP_3		3		dBm	$\Delta f = 1\text{ MHz}$, $P_{IN} = -28\text{ dBm}$
Input third order intercept point ¹⁾ (Off-State)	IIP_3		20		dBm	$\Delta f = 1\text{ MHz}$, $P_{IN} = -8\text{ dBm}$
Input power at 1 dB gain compression	P_{-1dB}		-13		dBm	

1) IP_3 values depends on termination of all intermodulation frequency components. Termination used for this measurement is $50\ \Omega$ from 0.1 to 6 GHz

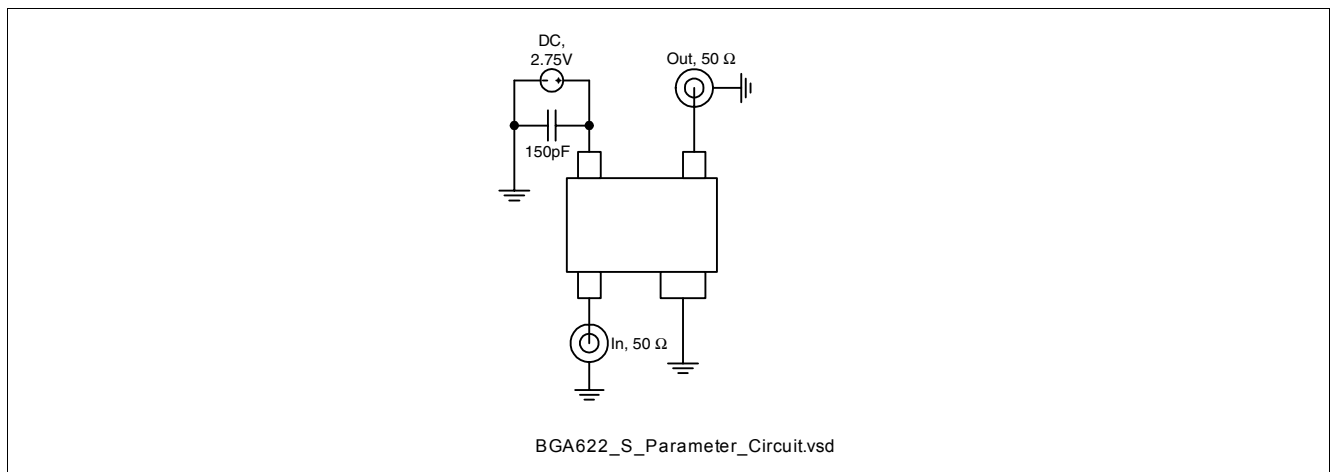

Figure 2 S-Parameter Test Circuit (loss-free microstrip test-fixture)

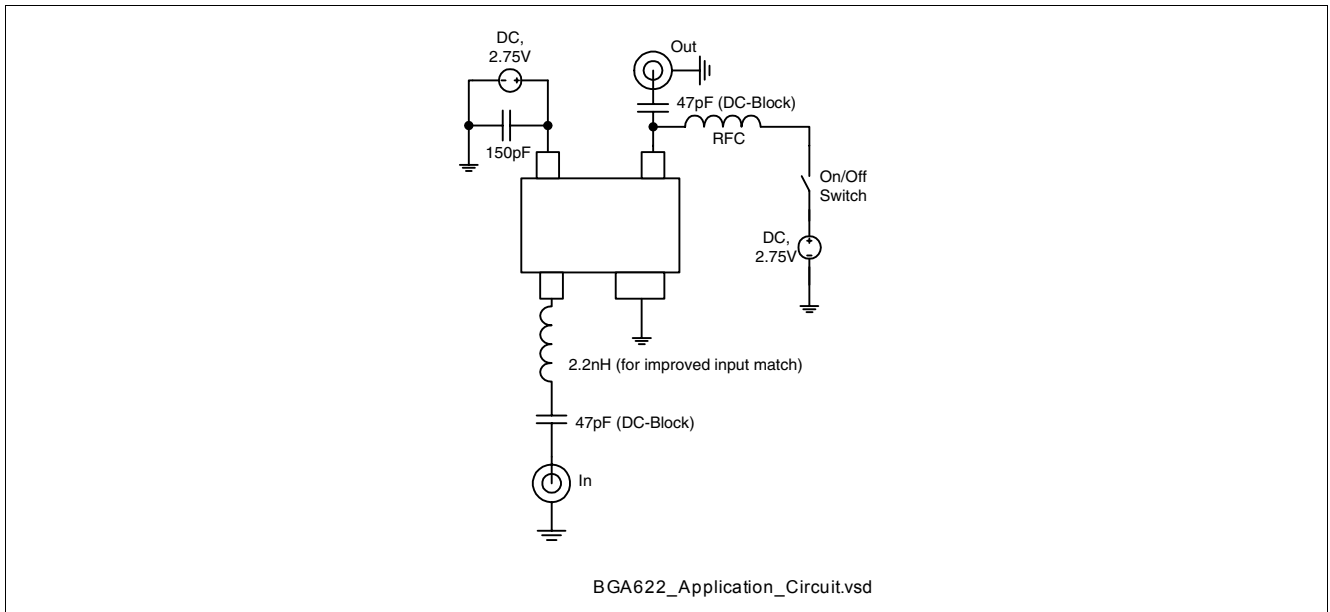
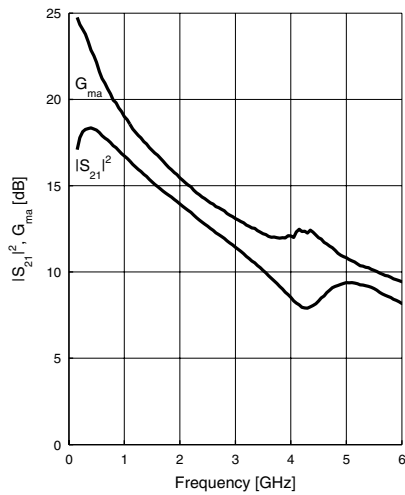

Figure 3 Application Circuit for 1800 - 2500 MHz

3 Measured Parameters

Power Gain $|S_{21}|^2, G_{ma} = f(f)$
 $V_{CC} = 2.75V, I_{tot-on} = 5.8mA$



Off Gain $|S_{21}|^2 = f(f)$
 $V_{CC} = 2.75V, V_{OUT} = 2.75V, I_{tot-off} = 0.3mA$

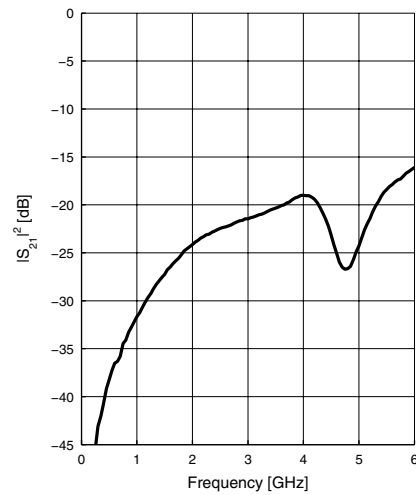

Reverse Isolation $|S_{12}| = f(f)$
 $V_{CC} = 2.75V, I_{tot-on} = 5.8mA$

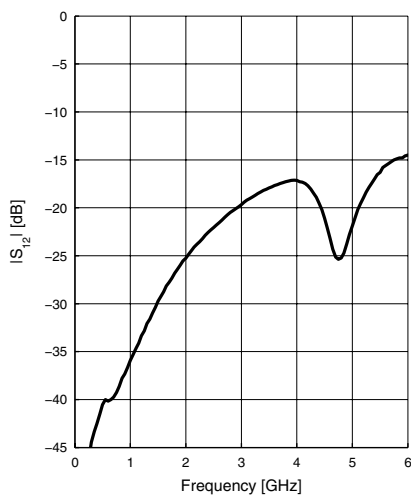

Matching $|S_{11}|, |S_{22}| = f(f)$
 $V_{CC} = 2.75V, I_{tot-on} = 5.8mA$

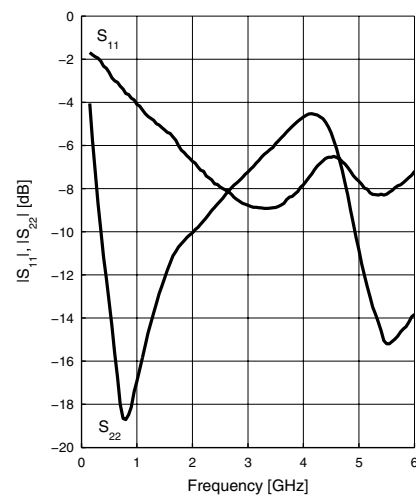

Stability K, B₁ = f(f)

V_{CC} = 2.75V, I_{tot-on} = 5.8mA

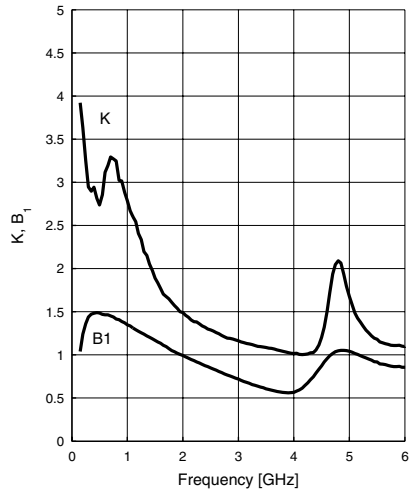

Noise Figure F = f(f)

V_{CC} = 2.75V, I_{tot-on} = 5.8mA, Z_S = 50Ω

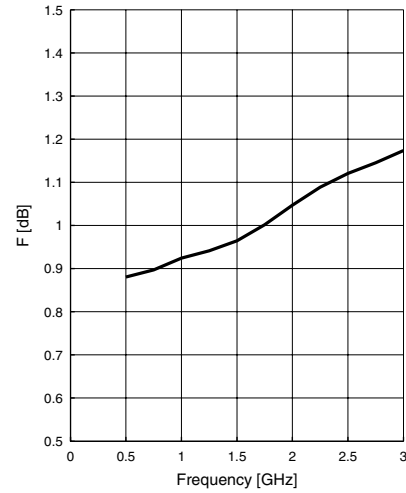

Input Compression Point P_{-1dB} = f(V_{CC})

f = 2.14GHz, T_A = parameter in °C

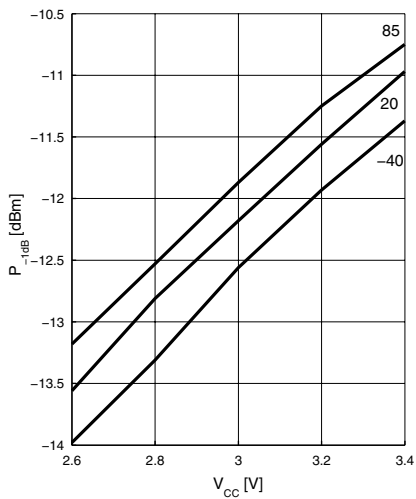

Device Current I_{tot-on} = f(T_A, V_{CC})

V_{CC} = parameter in V

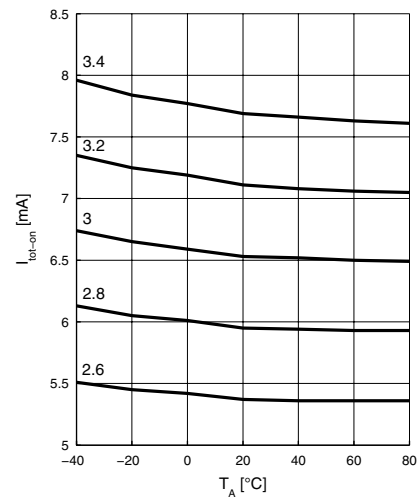

Device Current $I_{\text{tot-on}} = f(V_{\text{CC}}, T_A)$
 T_A = parameter in °C

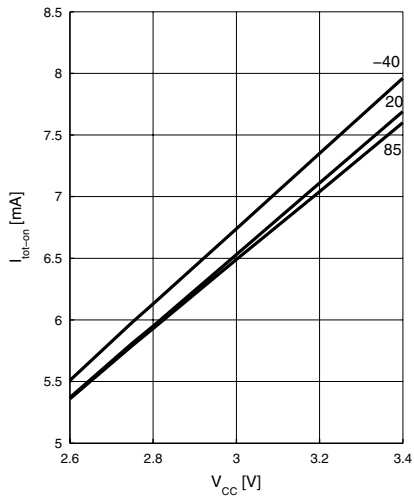

Power Gain $|S_{21}|^2 = f(T_A, V_{\text{CC}})$
 $f = 2.14\text{GHz}$, $V_{\text{CC}} = \text{parameter in V}$

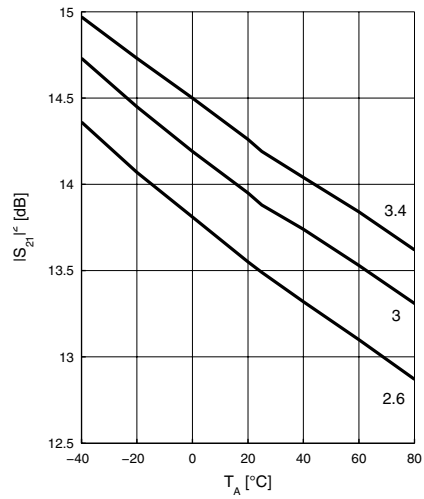

Power Gain $|S_{21}|^2 = f(V_{\text{CC}}, T_A)$
 $f = 2.14\text{GHz}$, $T_A = \text{parameter in } ^\circ\text{C}$

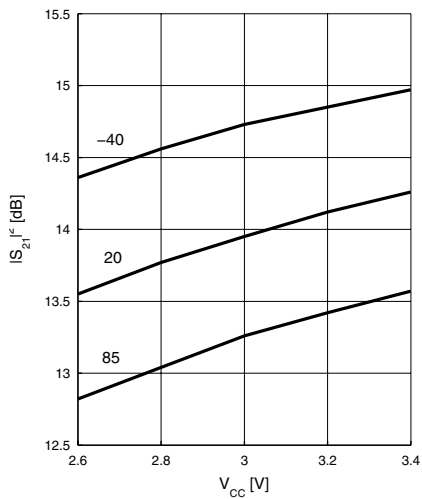

4 Package Information

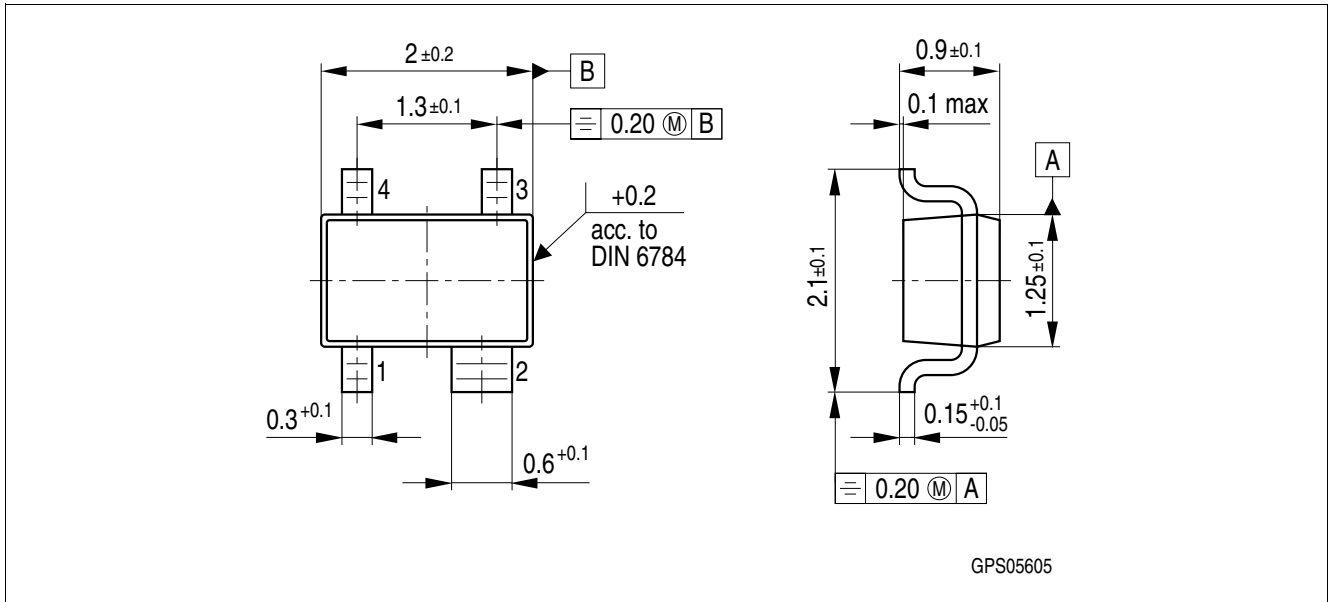

Figure 4 Package Outline SOT343

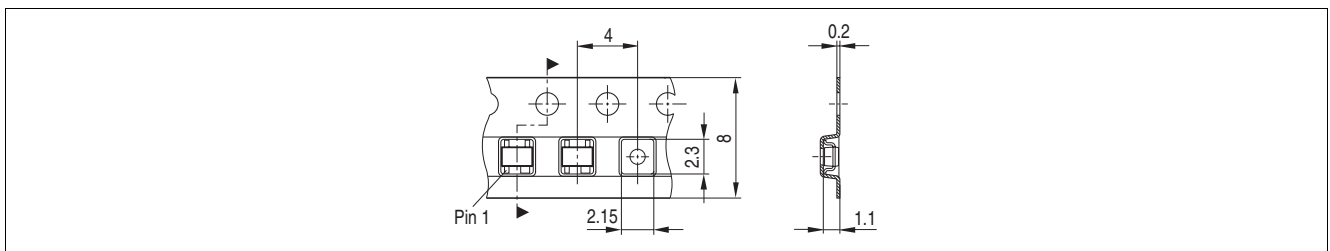

Figure 5 Tape for SOT343

X-ON Electronics

Largest Supplier of Electrical and Electronic Components

Click to view similar products for [RF Amplifier](#) category:

Click to view products by [Infineon](#) manufacturer:

Other Similar products are found below :

[A82-1](#) [BGA622H6820XTSA1](#) [BGA 728L7 E6327](#) [BGB719N7ESDE6327XTMA1](#) [HMC397-SX](#) [HMC405](#) [HMC561-SX](#) [HMC8120-SX](#)
[HMC8121-SX](#) [HMC-ALH382-SX](#) [HMC-ALH476-SX](#) [SE2433T-R](#) [SMA3101-TL-E](#) [SMA39](#) [A66-1](#) [A66-3](#) [A67-1](#) [LX5535LQ](#) [LX5540LL](#)
[MAAM02350](#) [HMC3653LP3BETR](#) [HMC549MS8GETR](#) [HMC-ALH435-SX](#) [SMA101](#) [SMA32](#) [SMA411](#) [SMA531](#) [SST12LP17E-XX8E](#)
[SST12LP19E-QX6E](#) [WPM0510A](#) [HMC5929LS6TR](#) [HMC5879LS7TR](#) [HMC1126](#) [HMC1087F10](#) [HMC1086](#) [HMC1016](#) [SMA1212](#)
[MAX2689EWS+T](#) [MAAMSS0041TR](#) [MAAM37000-A1G](#) [LTC6430AIUF-15#PBF](#) [CHA5115-QDG](#) [SMA70-2](#) [SMA4011](#) [A231](#) [HMC-](#)
[AUH232](#) [LX5511LQ](#) [LX5511LQ-TR](#) [HMC7441-SX](#) [HMC-ALH310](#)