

# BGA924N6

Silicon Germanium Low Noise Amplifier  
for Global Navigation Satellite Systems (GNSS)

## Data Sheet

Revision 3.0, 2014-01-24

**Edition 2014-01-24**

**Published by  
Infineon Technologies AG  
81726 Munich, Germany**

**© 2014 Infineon Technologies AG  
All Rights Reserved.**

### **Legal Disclaimer**

The information given in this document shall in no event be regarded as a guarantee of conditions or characteristics. With respect to any examples or hints given herein, any typical values stated herein and/or any information regarding the application of the device, Infineon Technologies hereby disclaims any and all warranties and liabilities of any kind, including without limitation, warranties of non-infringement of intellectual property rights of any third party.

### **Information**

For further information on technology, delivery terms and conditions and prices, please contact the nearest Infineon Technologies Office ([www.infineon.com](http://www.infineon.com)).

### **Warnings**

Due to technical requirements, components may contain dangerous substances. For information on the types in question, please contact the nearest Infineon Technologies Office.

Infineon Technologies components may be used in life-support devices or systems only with the express written approval of Infineon Technologies, if a failure of such components can reasonably be expected to cause the failure of that life-support device or system or to affect the safety or effectiveness of that device or system. Life support devices or systems are intended to be implanted in the human body or to support and/or maintain and sustain and/or protect human life. If they fail, it is reasonable to assume that the health of the user or other persons may be endangered.

**Revision History**

Page or Item	Subjects (major changes since previous revision)
<b>Revision 3.0, 2014-01-24</b>	
all	"Preliminary" status removed
<b>Revision 2.0, 2013-07-13</b>	
all	Preliminary Data Sheet
14, 15	Package drawings and information completed
7, 8, 10, 11	Electrical Characteristics adjusted

**Trademarks of Infineon Technologies AG**

AURIX™, C166™, CanPAK™, CIPOS™, CIPURSE™, EconoPACK™, CoolMOS™, CoolSET™, CORECONTROL™, CROSSAVE™, DAVE™, DI-POL™, EasyPIM™, EconoBRIDGE™, EconoDUAL™, EconoPIM™, EconoPACK™, EiceDRIVER™, eupec™, FCOS™, HITFET™, HybridPACK™, I<sup>2</sup>RF™, ISOFACE™, IsoPACK™, MIPAQ™, ModSTACK™, my-d™, NovalithIC™, OptiMOS™, ORIGA™, POWERCODE™, PRIMARION™, PrimePACK™, PrimeSTACK™, PRO-SIL™, PROFET™, RASIC™, ReverSave™, SatRIC™, SIEGET™, SINDRION™, SIPMOS™, SmartLEWIS™, SOLID FLASH™, TEMPFET™, thinQ!™, TRENCHSTOP™, TriCore™.

**Other Trademarks**

Advance Design System™ (ADS) of Agilent Technologies, AMBA™, ARM™, MULTI-ICE™, KEIL™, PRIMECELL™, REALVIEW™, THUMB™, µVision™ of ARM Limited, UK. AUTOSAR™ is licensed by AUTOSAR development partnership. Bluetooth™ of Bluetooth SIG Inc. CAT-iq™ of DECT Forum. COLOSSUS™, FirstGPS™ of Trimble Navigation Ltd. EMV™ of EMVCo, LLC (Visa Holdings Inc.). EPCOS™ of Epcos AG. FLEXGO™ of Microsoft Corporation. FlexRay™ is licensed by FlexRay Consortium. HYPERTERMINAL™ of Hilgraeve Incorporated. IEC™ of Commission Electrotechnique Internationale. IrDA™ of Infrared Data Association Corporation. ISO™ of INTERNATIONAL ORGANIZATION FOR STANDARDIZATION. MATLAB™ of MathWorks, Inc. MAXIM™ of Maxim Integrated Products, Inc. MICROTEC™, NUCLEUS™ of Mentor Graphics Corporation. MIPI™ of MIPI Alliance, Inc. MIPS™ of MIPS Technologies, Inc., USA. muRata™ of MURATA MANUFACTURING CO., MICROWAVE OFFICE™ (MWO) of Applied Wave Research Inc., OmniVision™ of OmniVision Technologies, Inc. Openwave™ Openwave Systems Inc. RED HAT™ Red Hat, Inc. RFMD™ RF Micro Devices, Inc. SIRIUS™ of Sirius Satellite Radio Inc. SOLARIS™ of Sun Microsystems, Inc. SPANSION™ of Spansion LLC Ltd. Symbian™ of Symbian Software Limited. TAIYO YUDEN™ of Taiyo Yuden Co. TEAKLITE™ of CEVA, Inc. TEKTRONIX™ of Tektronix Inc. TOKO™ of TOKO KABUSHIKI KAISHA TA. UNIX™ of X/Open Company Limited. VERILOG™, PALLADIUM™ of Cadence Design Systems, Inc. VLYNQ™ of Texas Instruments Incorporated. VXWORKS™, WIND RIVER™ of WIND RIVER SYSTEMS, INC. ZETEX™ of Diodes Zetex Limited.

Last Trademarks Update 2011-11-11

## Table of Contents

	<b>Table of Contents</b> .....	4
	<b>List of Figures</b> .....	5
	<b>List of Tables</b> .....	6
	<b>Features</b> .....	7
<b>1</b>	<b>Maximum Ratings</b> .....	9
<b>2</b>	<b>Electrical Characteristics</b> .....	10
<b>3</b>	<b>Application Information</b> .....	12
<b>4</b>	<b>Package Information</b> .....	14

## List of Figures

Figure 1	Block Diagram	7
Figure 2	Application Schematic BGA924N6	12
Figure 3	Drawing of Application Board	13
Figure 4	Application Board Cross-Section	13
Figure 5	TSNP-6-2 Package Outline (top, side and bottom views)	14
Figure 6	Footprint TSNP-6-2	14
Figure 7	Marking Layout (top view)	14
Figure 8	Tape & Reel Dimensions (reel diameter 180 mm, pieces/reel 15000)	15

## List of Tables

Table 1	Pin Definition and Function	8
Table 2	Maximum Ratings	9
Table 3	Thermal Resistance	9
Table 4	Electrical Characteristics: $T_A = 25\text{ °C}$ , $V_{CC} = 1.8\text{ V}$ , $V_{PON,ON} = 1.8\text{ V}$ , $V_{PON,OFF} = 0\text{ V}$ , $f = 1550 - 1615\text{ MHz}$ (GPS / Glonass / Beidou / Galileo)	10
Table 5	Electrical Characteristics: $T_A = 25\text{ °C}$ , $V_{CC} = 2.8\text{ V}$ , $V_{PON,ON} = 2.8\text{ V}$ , $V_{PON,OFF} = 0\text{ V}$ , $f = 1550 - 1615\text{ MHz}$ (GPS / Glonass / Beidou / Galileo)	11
Table 6	Bill of Materials	12

## Silicon Germanium Low Noise Amplifier for Global Navigation Satellite Systems (GNSS)

BGA924N6

### Features

- High insertion power gain: 16.2dB
- Out-of-band input 3rd order intercept point: +10dBm
- Input 1 dB compression point: -5 dBm
- Low noise figure: 0.55 dB
- Very low current consumption: 4.8 mA
- Operating frequencies: 1550 - 1615 MHz
- Supply voltage: 1.5 V to 3.3 V
- Digital on/off switch (1V logic high level)
- Ultra small TSNP-6-2 leadless package (footprint: 0.7 x 1.1 mm<sup>2</sup>)
- B7HF Silicon Germanium technology
- RF output internally matched to 50 Ω
- Only 1 external SMD component necessary
- 2kV HBM ESD protection (including AI-pin)
- Pb-free (RoHS compliant) package

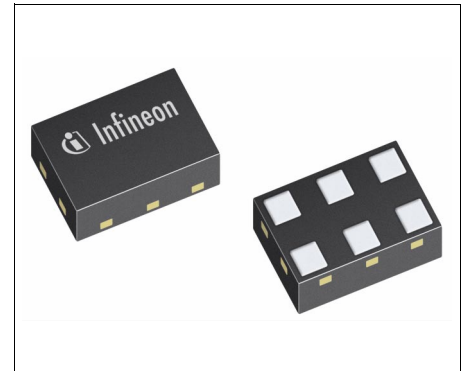

### Application

- Ideal for all Global Navigation Satellite Systems (GNSS) like GPS, GLONASS, Beidou, Galileo and others

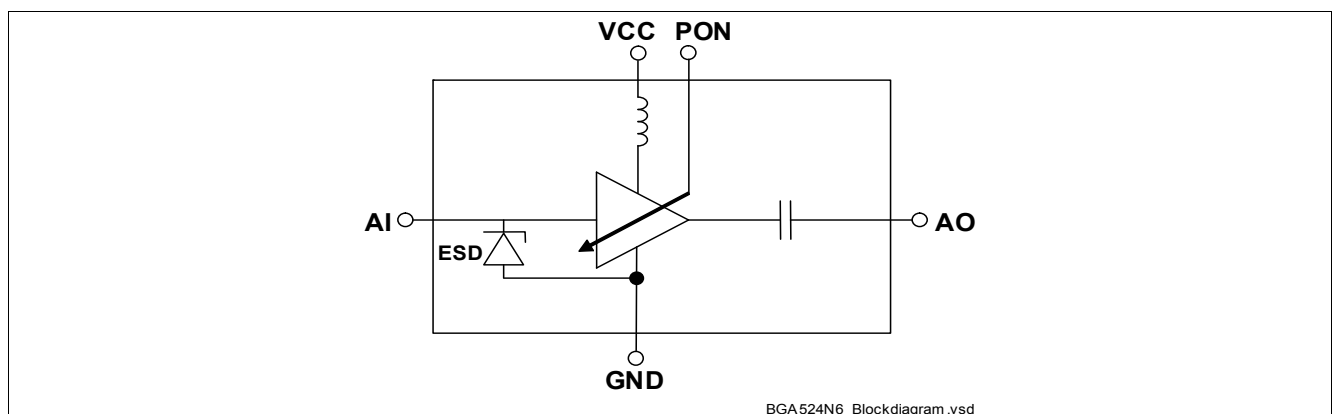

Figure 1 Block Diagram

Product Name	Marking	Package
BGA924N6	J	TSNP-6-2

**Description**

The BGA924N6 is a front-end low noise amplifier for Global Navigation Satellite Systems (GNSS) from 1550 MHz to 1615 MHz like GPS, GLONASS, Beidou, Galileo and others. The LNA provides 16.2 dB gain and 0.55 dB noise figure at a current consumption of 4.8 mA in the application configuration described in [Chapter 3](#). The BGA924N6 is based upon Infineon Technologies' B7HF Silicon Germanium technology. It operates from 1.5 V to 3.3 V supply voltage.

**Pin Definition and Function****Table 1 Pin Definition and Function**

Pin No.	Name	Function
1	GND	Ground
2	VCC	DC supply
3	AO	LNA output
4	GND	Ground
5	AI	LNA input
6	PON	Power on control



## 1 Maximum Ratings

**Table 2 Maximum Ratings**

Parameter	Symbol	Values			Unit	Note / Test Condition
		Min.	Typ.	Max.		
Voltage at pin VCC	$V_{CC}$	-0.3	–	3.6	V	1)
Voltage at pin AI	$V_{AI}$	-0.3	–	0.9	V	–
Voltage at pin AO	$V_{AO}$	-0.3	–	$V_{CC} + 0.3$	V	–
Voltage at pin PON	$V_{PON}$	-0.3	–	$V_{CC} + 0.3$	V	–
Voltage at pin GNDRF	$V_{GNDRF}$	-0.3	–	0.3	V	–
Current into pin VCC	$I_{CC}$	–	–	16	mA	–
RF input power	$P_{IN}$	–	–	0	dBm	–
Total power dissipation, $T_S < 148\text{ °C}^2)$	$P_{tot}$	–	–	60	mW	–
Junction temperature	$T_J$	–	–	150	°C	–
Ambient temperature range	$T_A$	-40	–	85	°C	–
Storage temperature range	$T_{STG}$	-65	–	150	°C	–
ESD capability all pins	$V_{ESD\_HBM}$	–	–	2000	V	according to JESD22A-114

1) All voltages refer to GND-Node unless otherwise noted

2)  $T_S$  is measured on the ground lead at the soldering point

**Attention: Stresses above the max. values listed here may cause permanent damage to the device. Exposure to absolute maximum rating conditions for extended periods may affect device reliability. Maximum ratings are absolute ratings; exceeding only one of these values may cause irreversible damage to the integrated circuit.**

### Thermal Resistance

**Table 3 Thermal Resistance**

Parameter	Symbol	Value	Unit
Junction - soldering point <sup>1)</sup>	$R_{thJS}$	25	K/W

1) For calculation of  $R_{thJA}$  please refer to Application Note Thermal Resistance

## 2 Electrical Characteristics

**Table 4** Electrical Characteristics:<sup>1)</sup>  $T_A = 25\text{ °C}$ ,  $V_{CC} = 1.8\text{ V}$ ,  $V_{PON,ON} = 1.8\text{ V}$ ,  $V_{PON,OFF} = 0\text{ V}$ ,  
 $f = 1550 - 1615\text{ MHz}$  (GPS / Glonass / Beidou / Galileo)

Parameter	Symbol	Values			Unit	Note / Test Condition
		Min.	Typ.	Max.		
Supply voltage	$V_{CC}$	1.5	–	3.3	V	–
Supply current	$I_{CC}$	–	4.8	–	mA	ON-mode
		–	0.2	3	$\mu\text{A}$	OFF-mode
Power On voltage	$V_{pon}$	1.0	–	$V_{CC}$	V	ON-mode
		0	–	0.4	V	OFF-mode
Power On current	$I_{pon}$	–	5	–	$\mu\text{A}$	ON-mode
		–	–	1	$\mu\text{A}$	OFF-mode
Insertion power gain	$ S_{21} ^2$	–	16.2	–	dB	–
Noise figure <sup>2)</sup>	$NF$	–	0.55	–	dB	$Z_S = 50\ \Omega$
Input return loss	$RL_{in}$	–	13	–	dB	–
Output return loss	$RL_{out}$	–	18	–	dB	–
Reverse isolation	$1/ S_{12} ^2$	–	23	–	dB	–
Power gain settling time <sup>3)</sup>	$t_S$	–	5	–	$\mu\text{s}$	OFF- to ON-mode
		–	5	–	$\mu\text{s}$	ON- to OFF-mode
Inband input 1dB-compression point	$IP_{1dB}$	–	-8	–	dBm	–
Inband input 3 <sup>rd</sup> -order intercept point <sup>4)</sup>	$IIP_3$	–	+3	–	dBm	$f_1 = 1575\text{ MHz}$ $f_2 = f_1 \pm 1\text{ MHz}$
Out-of-band input 3 <sup>rd</sup> -order intercept point <sup>5)</sup>	$IIP_{3oob}$	–	+10	–	dBm	$f_1 = 1712.7\text{ MHz}$ $f_2 = 1850\text{ MHz}$
Stability	$k$	–	> 1	–		$f = 20\text{ MHz} \dots 10\text{ GHz}$

1) Based on the application described in chapter 3

2) PCB losses are subtracted

3) To be within 1 dB of the final gain OFF- to ON-mode; to be within 3 dB of the final gain ON- to OFF-mode

4) Input power = -30 dBm for each tone

5) Input power = -20 dBm for each tone

**Table 5 Electrical Characteristics:**<sup>1)</sup>  $T_A = 25\text{ °C}$ ,  $V_{CC} = 2.8\text{ V}$ ,  $V_{PON,ON} = 2.8\text{ V}$ ,  $V_{PON,OFF} = 0\text{ V}$ ,  
 $f = 1550 - 1615\text{ MHz}$  (GPS / Glonass / Beidou / Galileo)

Parameter	Symbol	Values			Unit	Note / Test Condition
		Min.	Typ.	Max.		
Supply voltage	$V_{CC}$	1.5	–	3.3	V	–
Supply current	$I_{CC}$	–	4.9	–	mA	ON-mode
		–	0.2	3	μA	OFF-mode
Power On voltage	$V_{pon}$	1.0	–	$V_{cc}$	V	ON-mode
		0	–	0.4	V	OFF-mode
Power On current	$I_{pon}$	–	10	–	μA	ON-mode
		–	–	1	μA	OFF-mode
Insertion power gain	$ S_{21} ^2$	–	16.2	–	dB	–
Noise figure <sup>2)</sup>	$NF$	–	0.55	–	dB	$Z_S = 50\ \Omega$
Input return loss	$RL_{in}$	–	13	–	dB	–
Output return loss	$RL_{out}$	–	20	–	dB	–
Reverse isolation	$1/ S_{12} ^2$	–	23	–	dB	–
Power gain settling time <sup>3)</sup>	$t_S$	–	5	–	μs	OFF- to ON-mode
		–	5	–	μs	ON- to OFF-mode
Inband input 1dB-compression point	$IP_{1dB}$	–	-5	–	dBm	–
Inband input 3 <sup>rd</sup> -order intercept point <sup>4)</sup>	$IIP_3$	–	+4	–	dBm	$f_1 = 1575\text{ MHz}$ $f_2 = f_1 \pm 1\text{ MHz}$
Out-of-band input 3 <sup>rd</sup> -order intercept point <sup>5)</sup>	$IIP_{3oob}$	–	+10	–	dBm	$f_1 = 1712.7\text{ MHz}$ $f_2 = 1850\text{ MHz}$
Stability	$k$	–	> 1	–		$f = 20\text{ MHz} \dots 10\text{ GHz}$

1) Based on the application described in chapter 3

2) PCB losses are subtracted

3) To be within 1 dB of the final gain OFF- to ON-mode; to be within 3 dB of the final gain ON- to OFF-mode

4) Input power = -30 dBm for each tone

5) Input power = -20 dBm for each tone

### 3 Application Information

#### Application Board Configuration

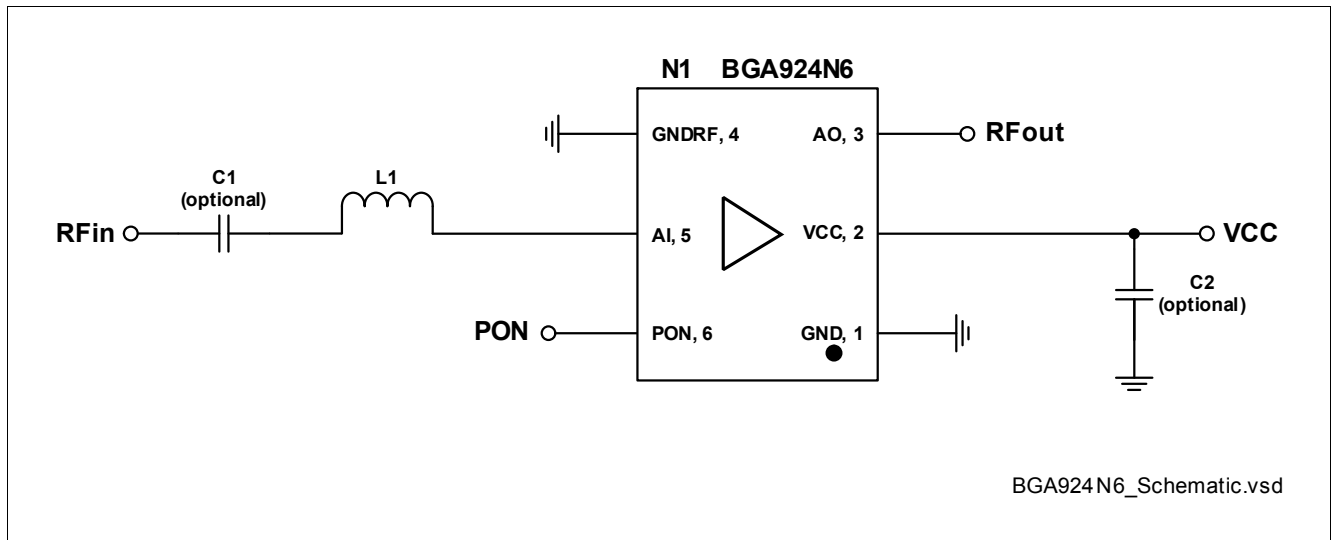

Figure 2 Application Schematic BGA924N6

Table 6 Bill of Materials

Name	Value	Package	Manufacturer	Function
C1 (optional)	1nF	0402	Various	DC block <sup>1)</sup>
C2 (optional)	> 10nF <sup>2)</sup>	0402	Various	RF bypass <sup>3)</sup>
L1	8.2nH	0402	Murata LQW type	Input matching
N1	BGA924N6	TSNP-6-2	Infineon	SiGe LNA

1) DC block might be realized with pre-filter in GNSS applications

2) For data sheet characteristics 1 $\mu$ F used

3) RF bypass recommended to mitigate power supply noise

A list of all application notes is available at <http://www.infineon.com/gpsIna.appnotes>.

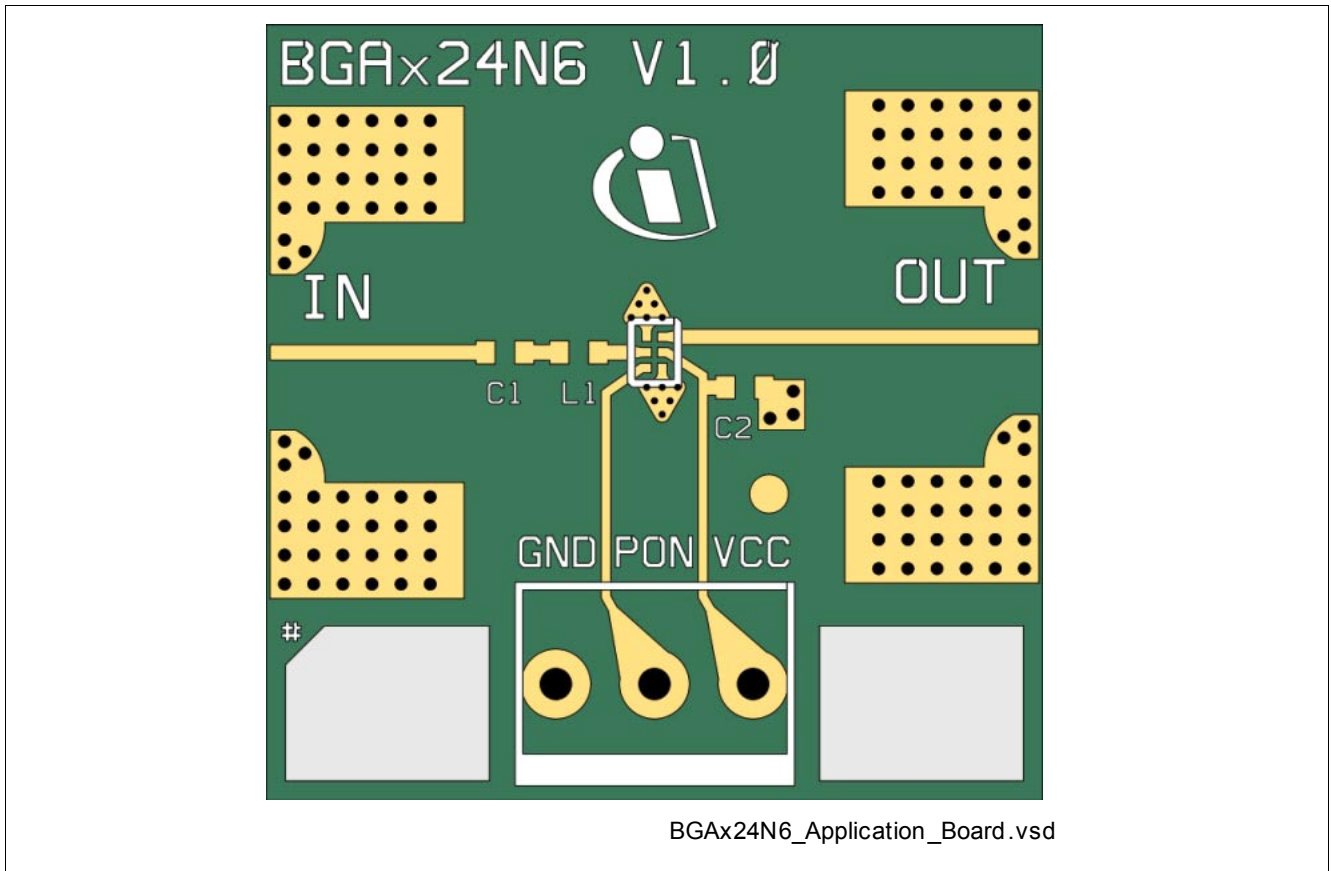

Figure 3 Drawing of Application Board

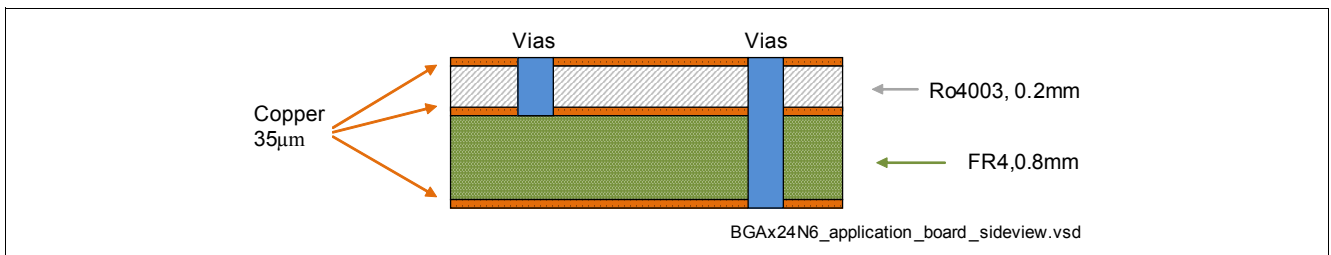

Figure 4 Application Board Cross-Section

## 4 Package Information

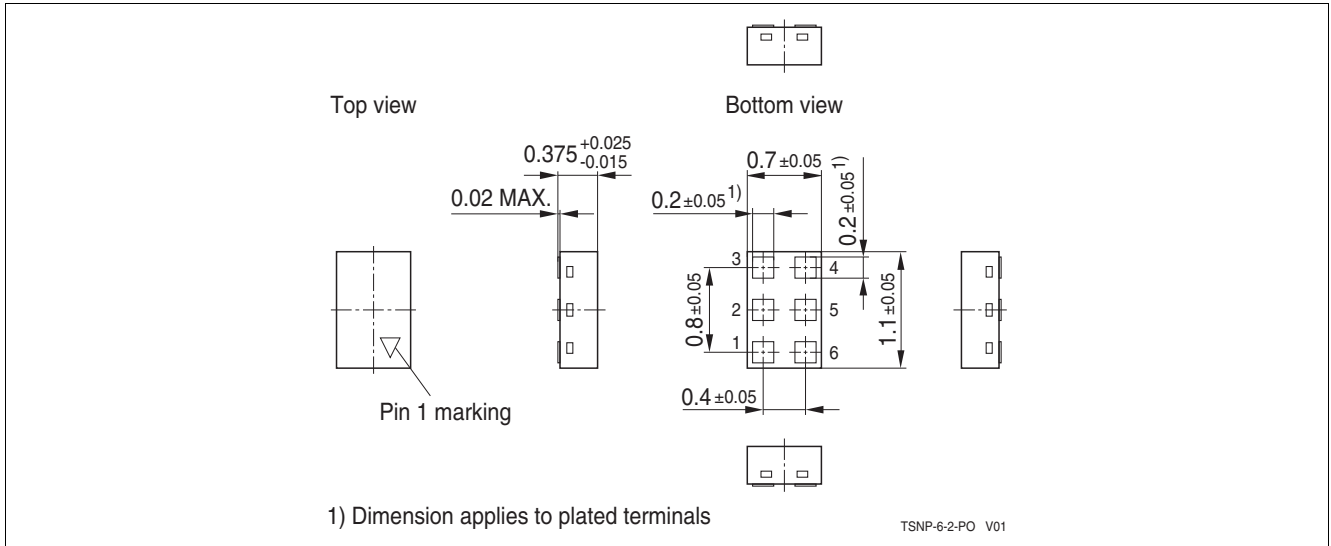

Figure 5 TSNP-6-2 Package Outline (top, side and bottom views)

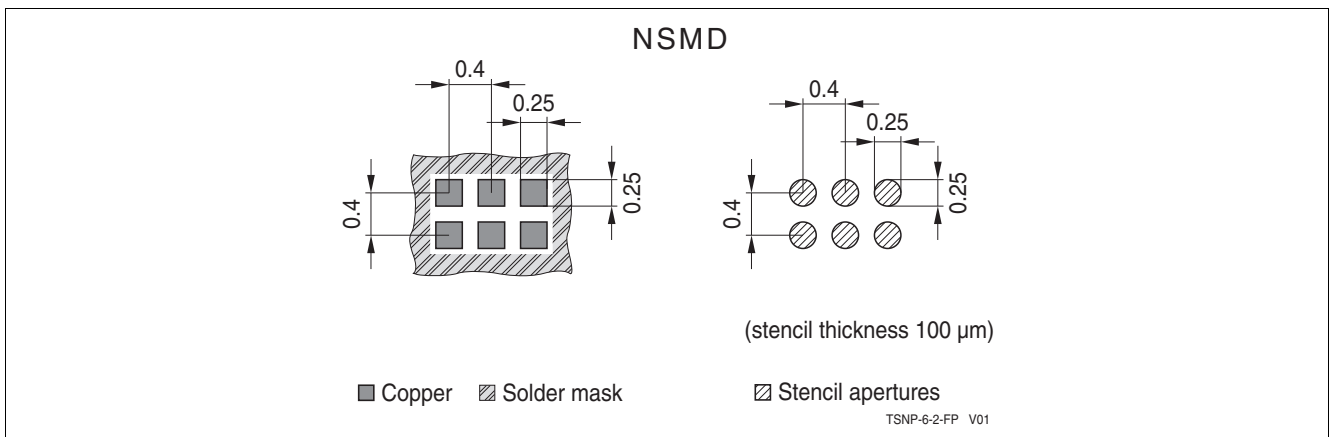

Figure 6 Footprint Recommendation TSNP-6-2

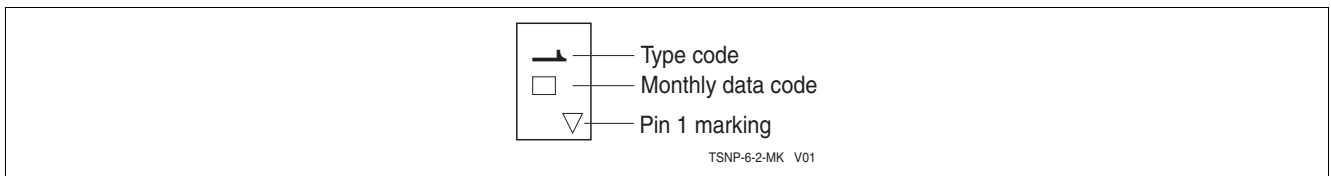
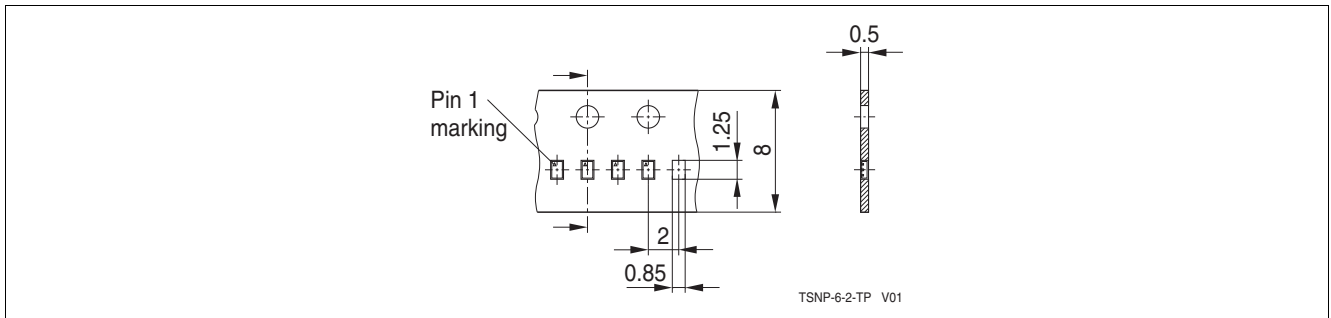

Figure 7 Marking Layout (top view)



**Figure 8 Tape & Reel Dimensions (reel diameter 180 mm, pieces/reel 15000)**

[www.infineon.com](http://www.infineon.com)

Published by Infineon Technologies AG



## X-ON Electronics

Largest Supplier of Electrical and Electronic Components

*Click to view similar products for [RF Amplifier](#) category:*

*Click to view products by [Infineon](#) manufacturer:*

Other Similar products are found below :

[A82-1](#) [BGA622H6820XTSA1](#) [BGA 728L7 E6327](#) [BGB719N7ESDE6327XTMA1](#) [HMC397-SX](#) [HMC405](#) [HMC561-SX](#) [HMC8120-SX](#)  
[HMC8121-SX](#) [HMC-ALH382-SX](#) [HMC-ALH476-SX](#) [SE2433T-R](#) [SMA3101-TL-E](#) [SMA39](#) [A66-1](#) [A66-3](#) [A67-1](#) [LX5535LQ](#) [LX5540LL](#)  
[MAAM02350](#) [HMC3653LP3BETR](#) [HMC549MS8GETR](#) [HMC-ALH435-SX](#) [SMA101](#) [SMA32](#) [SMA411](#) [SMA531](#) [SST12LP17E-XX8E](#)  
[SST12LP19E-QX6E](#) [WPM0510A](#) [HMC5929LS6TR](#) [HMC5879LS7TR](#) [HMC1126](#) [HMC1087F10](#) [HMC1086](#) [HMC1016](#) [SMA1212](#)  
[MAX2689EWS+T](#) [MAAMSS0041TR](#) [MAAM37000-A1G](#) [LTC6430AIUF-15#PBF](#) [CHA5115-QDG](#) [SMA70-2](#) [SMA4011](#) [A231](#) [HMC-](#)  
[AUH232](#) [LX5511LQ](#) [LX5511LQ-TR](#) [HMC7441-SX](#) [HMC-ALH310](#)