

Demoboard BTS3xxxEJ

About this document

Scope and purpose

This document gives a fast introduction to the BTS3xxxEJ demoboard.

Intended audience

Engineers, hobbyists and students who want to add powerful Low Side Switches to their projects.

Related information

Table 1 Supplementary links and document references

Reference	Description
HITFET Home Page	Product page which contains reference information for the HITFET+ family
Arduino Home Page	All information on Arduino
Arduino Uno Product Page	Arduino Uno R3 description
DAVE™ Development Platform	All details on DAVE™ IDE
XMC1100 Boot Kit	Product page which contains reference information for the XMC1100 Boot Kit

1 Demoboard BTS3xxxEJ

Note: The following information is given as a hint for the implementation of the device only and shall not be regarded as a description or warranty of a certain functionality, condition or quality of the device

Basic Features of this Demoboard

- RoHS compliant
- Driving one 12V resistive, capacitive or inductive load
- Arduino/XMC1100 Boot Kit compatible
- Diagnosis function
- Programmable push button integrated
- Additional equipment needed: 1x 12V power supply; 1x 5V signal generator and 5V power supply, or Arduino Uno/XMC1100 Boot Kit

Description of how to use the Demoboard

This description is intended to give a fast introduction to the BTS3xxxEJ demoboard. The demoboard gives the user a quick start for lab evaluation of the BTS3xxxEJ. Stand-alone operation is possible.

The BTS3xxxEJ demoboard (PCB size: 53 x 58 mm²) has 2 layers (70µm copper). It is equipped with one sample of BTS3035EJ, BTS3050EJ, BTS3080EJ, or BTS3125EJ. **Figure 1** gives an overview of the demoboard. **Table 2** provides a description of major parts of the demoboard. The schematic and an example for external connection are given in **Figure 2** and **Figure 3**.

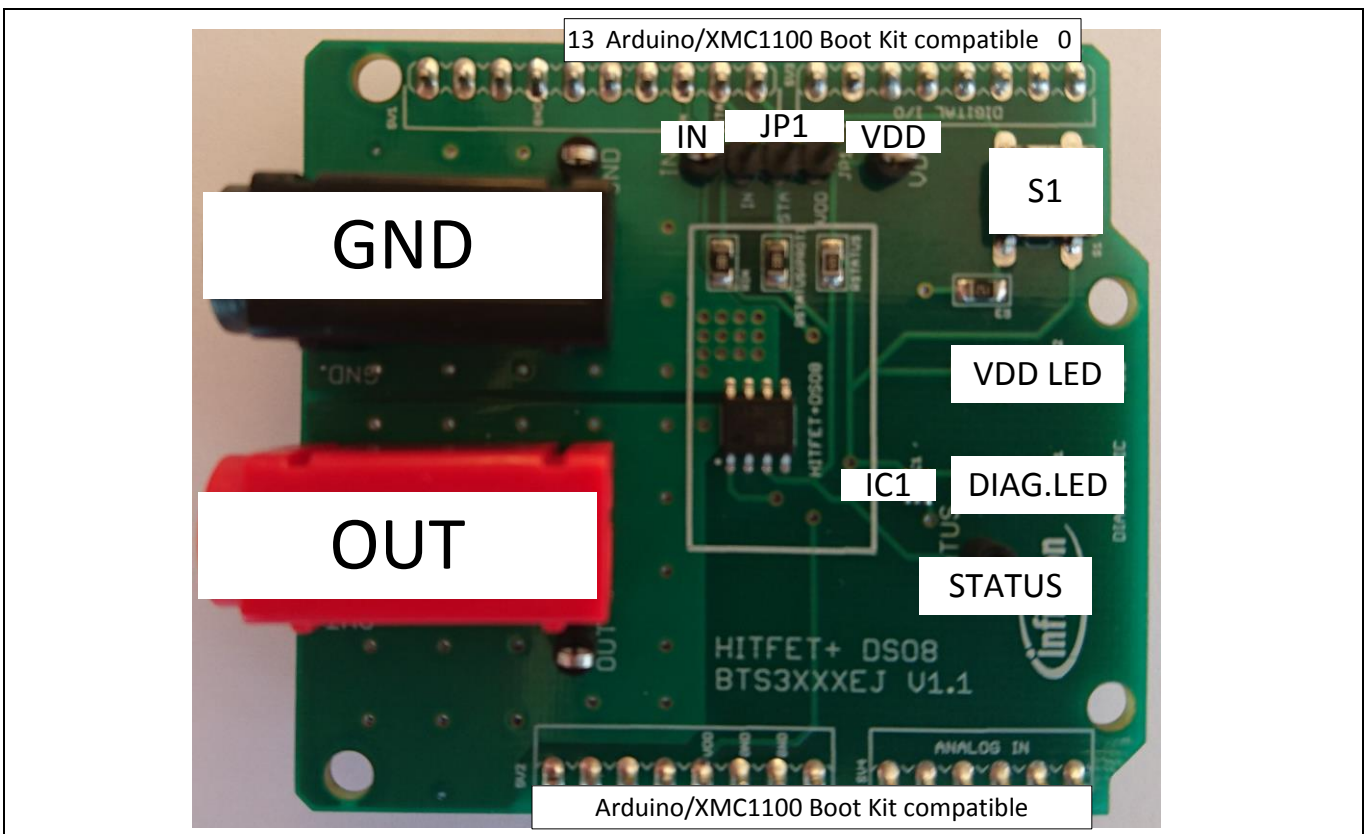

Figure 1 Board Overview

Table 2 Part Description

Name	Description
IN	Input signal; TTL logic level (5V recommended), can be supplied with Arduino/XMC1100 Boot Kit
OUT	Output/Load; refers to the OUT pin of the device. Load to battery supply line. For inductive loads check energy capabilities on device datasheet
GND	Ground; connect all grounds to this pin
STA	Output signal for diagnostic function; if $V_{STA} = 0V$, fault feedback is present. Fault feedback resets if $V_{IN}=0V$. For use with microcontroller (include $R_{STATUS(Prot)}$)
STATUS	Output signal for diagnostic function; if $V_{STA} = 0V$, fault feedback is present. Fault feedback resets if $V_{IN}=0V$. To be used as test point
VDD	Supply voltage; connect with 5V, if no Arduino/XMC1100 Boot Kit is used
DIAGNOSTIC LED	FAULT indicator; If LED (red) is on, the fault feedback is active
VDD LED	VDD supply indicator; If LED (green) is on, VDD supply is connected
S1	Push button with pull down resistor for customizable use; programmable via Arduino/XMC1100 Boot Kit
JP1	To be used as extra testing points for IN, STA and VDD. Short STA with IN or VDD is not needed
IC1	Inverter; Inverts signal of V_{STATUS} in order to turn DIAGNOSTIC LED on/off (74LVC1G14GW-Q100)

Table 3 Arduino Uno/XMC1100 Boot Kit Pin Out

Arduino Uno	XMC1100 Boot Kit	Description
8	P0.12	S1
9	P0.8	STA
10	P0.9	IN
GND	GND	GND
5V	5V	VDD

Demoboard BTS3xxxEJ

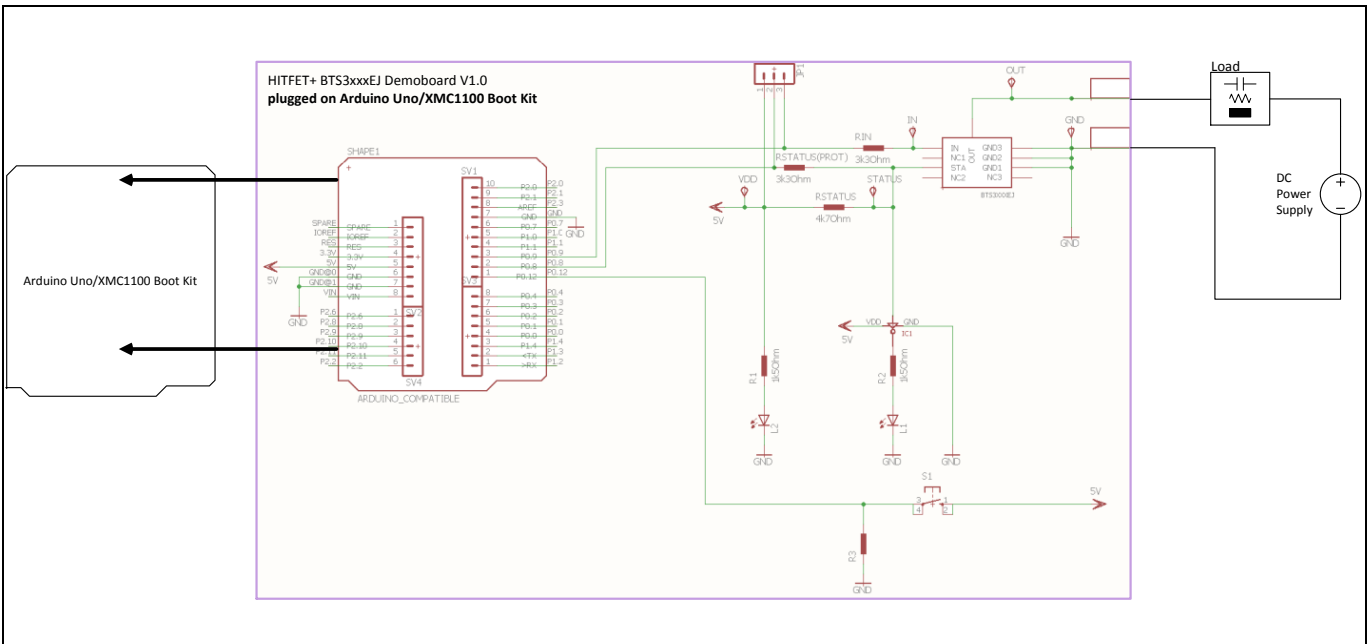

Figure 2 Demoboard Setup with Arduino Uno / XMC1100 Boot Kit

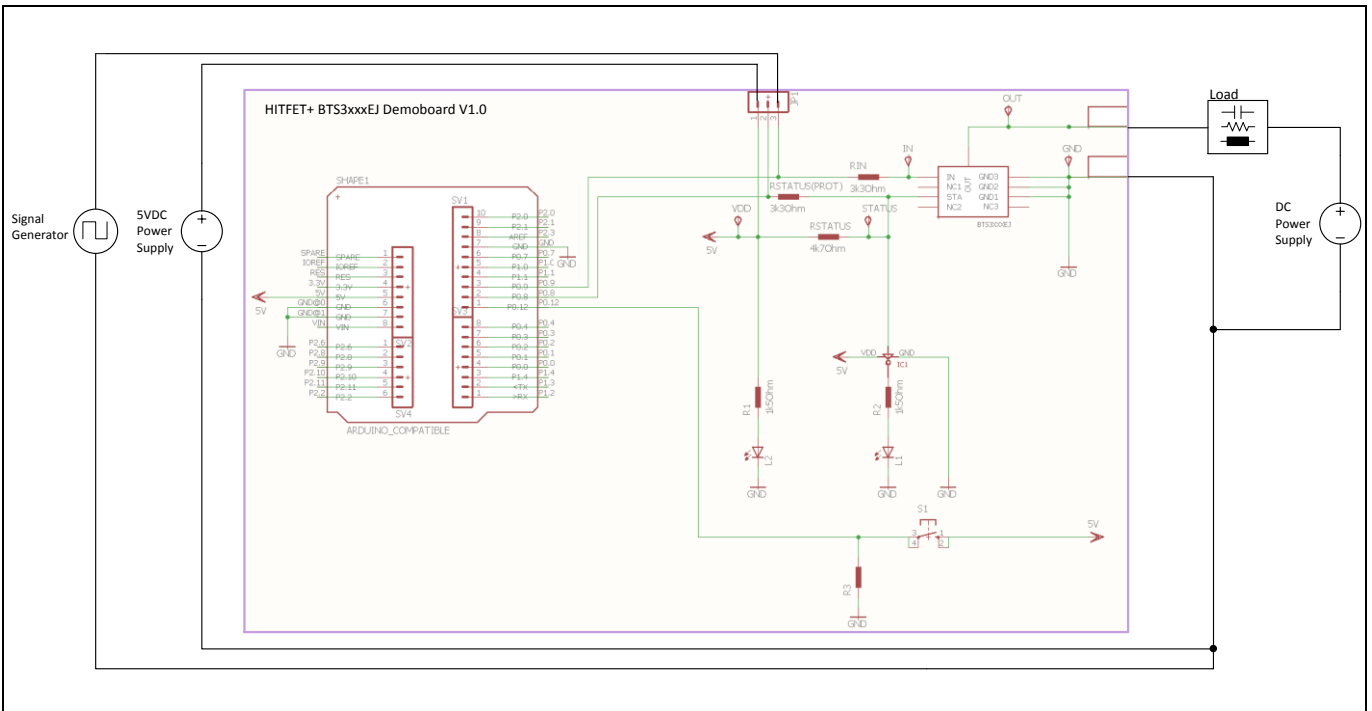

Figure 3 Demoboard Setup stand-alone

Note: Figure 2 and Figure 3 show the demoboard schematics and a very simplified application example. The function in real applications must be verified to not exceed the limits of the device nor the demoboard and its components.



Revision History

Major changes since the last revision

Page or Reference	Description of change
V1.0	Release of Demoboard Description

Trademarks of Infineon Technologies AG

AURIX™, C166™, CanPAK™, CIPOS™, CoolGaN™, CoolMOS™, CoolSET™, CoolSiC™, CORECONTROL™, CROSSAVE™, DAVE™, DI-POL™, DrBlade™, EasyPIM™, EconoBRIDGE™, EconoDUAL™, EconoPACK™, EconoPIM™, EiceDRIVER™, eupec™, FCOS™, HITFET™, HybridPACK™, Infineon™, ISOFACE™, IsoPACK™, i-Wafer™, MIPAQ™, ModSTACK™, my-d™, NovalithIC™, OmniTune™, OPTIGA™, OptiMOS™, ORIGA™, POWERCODE™, PRIMARION™, PrimePACK™, PrimeSTACK™, PROFET™, PRO-SIL™, RASIC™, REAL3™, ReverSave™, SatRIC™, SIEGET™, SIPMOS™, SmartLEWIS™, SOLID FLASH™, SPOC™, TEMPFET™, thinQ!™, TRENCHSTOP™, TriCore™.

Trademarks updated August 2015

Other Trademarks

All referenced product or service names and trademarks are the property of their respective owners.

Edition <2016-11-30>

Published by

Infineon Technologies AG

81726 Munich, Germany

© 2016 Infineon Technologies AG.

All Rights Reserved.

Do you have a question about this document?

Email: erratum@infineon.com

**Document reference
Demoboard Description**

IMPORTANT NOTICE

The information contained in this application note is given as a hint for the implementation of the product only and shall in no event be regarded as a description or warranty of a certain functionality, condition or quality of the product. Before implementation of the product, the recipient of this application note must verify any function and other technical information given herein in the real application. Infineon Technologies hereby disclaims any and all warranties and liabilities of any kind (including without limitation warranties of non-infringement of intellectual property rights of any third party) with respect to any and all information given in this application note.

The data contained in this document is exclusively intended for technically trained staff. It is the responsibility of customer's technical departments to evaluate the suitability of the product for the intended application and the completeness of the product information given in this document with respect to such application.

For further information on the product, technology, delivery terms and conditions and prices please contact your nearest Infineon Technologies office (www.infineon.com).

WARNINGS

Due to technical requirements products may contain dangerous substances. For information on the types in question please contact your nearest Infineon Technologies office.

Except as otherwise explicitly approved by Infineon Technologies in a written document signed by authorized representatives of Infineon Technologies, Infineon Technologies' products may not be used in any applications where a failure of the product or any consequences of the use thereof can reasonably be expected to result in personal injury.

X-ON Electronics

Largest Supplier of Electrical and Electronic Components

Click to view similar products for [Power Management IC Development Tools](#) category:

Click to view products by [Infineon](#) manufacturer:

Other Similar products are found below :

[EVB-EP5348UI](#) [BQ25010EVM](#) [ISL80019AEVAL1Z](#) [ISLUSBI2CKIT1Z](#) [ISL8002AEVAL1Z](#) [ISL91108IIA-EVZ](#) [MAX8556EVKIT](#)
[MAX15005AEVKIT+](#) [ISL28022EVKIT1Z](#) [STEVAL-ISA008V1](#) [DRI0043](#) [KITPF8100FRDMEVM](#) [EVB-EN6337QA](#)
[SAMPLEBOXILD8150TOBO1](#) [MAX18066EVKIT#](#) [AP62300WU-EVM](#) [KITA2GTC387MOTORCTRTOBO1](#) [AEK-MOT-TK200G1](#)
[EVLONE65W](#) [STEVAL-ILH006V1](#) [STEVAL-IPE008V2](#) [STEVAL-IPP001V2](#) [STEVAL-ISA013V1](#) [STEVAL-ISA067V1](#) [STEVAL-](#)
[ISQ002V1](#) [TPS2306EVM-001](#) [TPS2330EVM-185](#) [TPS40001EVM-001](#) [SECO-HVDCDC1362-15W-GEVB](#) [BTS7030-2EPA](#)
[LT8638SJV#WPBF](#) [LTC3308AIV#WTRPBF](#) [TLT807B0EPV](#) [BTS71033-6ESA](#) [EV13N91A](#) [EASYPIC V8 OVER USB-C](#) [EV55W64A](#)
[CLICKER 4 FOR STM32F4](#) [EASYMX PRO V7A FOR STM32](#) [CLICKER 4 FOR PIC18F](#) [Si8285_86v2-KIT](#) [PAC52700EVK1](#) [NCP-](#)
[NCV51752D2PAK3LGEVB](#) [ISL81807EVAL1Z](#) [AP33772S-EVB](#) [EVALM7HVIGBTFCINV4TOBO1](#) [903-0300-000](#) [902-0173-000](#) [903-](#)
[0301-000](#) [ROA1286023/1](#)