

SPOC™ + 12V

BTS54040-LBA

SPI Power Controller

Data Sheet

Rev. 2.2, 2016-10-10

Automotive

---

**Revision History**

Page or Item	Subjects (major changes since previous revision)
--------------	--

**Rev. 2.2, 2016-10-10**

All	Package name changed General: Typos corrected and wording improved <b>Table 1</b> : Channel description improved <b>Table 4</b> : Footnote added <b>Table 5</b> : Updated and Footnote added <b>Chapter 5.1.3</b> : Updated <b>Chapter 5.1.6</b> : Note added <b>Chapter 5.2</b> : Updated <b>Chapter 6.3</b> : Updated <b>Chapter 7.2</b> : Updated <b>Figure 28</b> updated
-----	---

## Revision History

Page or Item	Subjects (major changes since previous revision)
<b>Rev. 2.0, 2014-05-26</b>	
All	<p>General: Numbering of Figures and Tables changed</p> <p><b>Table 1</b> updated</p> <p><b>Chapter 4.2.1</b> added</p> <p><b>Chapter 4.2.2</b> added</p> <p>Parameter P_4.1.4: number changed to P_4.1.5 and max. value improved</p> <p>Parameter P_4.1.11: Max. Value improved</p> <p>Parameter P_4.1.28: Max. Value improved</p> <p>Parameter P_4.1.31: Max. Value improved</p> <p>Parameter P_4.1.34: Max. Value improved</p> <p>Parameter P_4.1.37: Max. Value improved</p> <p>Parameter P_4.1.39: Min. Value improved</p> <p>Parameter P_4.1.42: Max. Value improved</p> <p><b>Chapter 5</b> rewritten (content improved)</p> <p>Parameter P_5.3.7: Max. Value improved</p> <p>Parameter P_5.3.8: Test Condition updated and Max. Value improved</p> <p>Parameter P_5.3.10: Max. Value improved</p> <p>Parameter P_5.3.13: Test Condition updated</p> <p>Parameter P_5.3.14: Max. Value improved</p> <p>Parameter P_5.3.16: Typ. and Max. value improved</p> <p>Parameter P_5.3.17: Typ. and Min. Value improved</p> <p>Parameter P_5.3.23: Max. Value improved</p> <p><b>Chapter 6.1:</b> <math>R_{DS(ON)}</math> graphs removed</p> <p><b>Chapter 6.1:</b> <math>R_{DS(ON)}</math> variation factor added</p> <p><b>Chapter 6.4:</b> Description improved</p> <p><b>Figure 16:</b> Content updated</p> <p><b>Chapter 6.4.4:</b> Note added</p> <p><b>Chapter 7.1:</b> Content improved</p> <p><b>Chapter 7.1:</b> <math>I_{L(LIM)}</math> graphs removed</p> <p><b>Chapter 7.1:</b> <math>I_{L(LIM)}</math> variation factor added</p> <p><b>Chapter 7.2:</b> Content improved</p> <p><b>Figure 18:</b> Content updated</p> <p><b>Figure 19:</b> Content and Title updated</p> <p><b>Figure 20:</b> added</p> <p>Undervoltage Behavior shifted from Chapter 7.4 to <b>Chapter 5.2.1</b></p> <p><b>Figure 21:</b> Content updated</p> <p><b>Chapter 8.1:</b> Content improved</p> <p><b>Figure 22:</b> Content updated</p> <p><b>Figure 23:</b> Content updated</p> <p><b>Chapter 8.2.3</b> added</p> <p><b>Chapter 8.4:</b> Content improved</p> <p>Parameter P_8.5.118 added</p>

**Revision History**

Page or Item	Subjects (major changes since previous revision)
	Parameter P_9.4.19: Test Condition updated Parameter P_9.4.20: Test Condition updated Parameter P_9.4.22: Max. Value improved Parameter P_9.4.24: Min. Value improved Parameter P_9.4.26: Min. Value improved Parameter P_9.4.28: Min. Value improved Parameter P_9.4.30: Min. Value improved Parameter P_9.4.32: Min. Value improved Parameter P_9.4.34: Test Condition updated and Max. Value improved <b>Chapter 9.5:</b> Content improved <b>Figure 33:</b> Content updated <b>Figure 34:</b> Content updated <b>Chapter 9.6:</b> Content improved <b>Chapter 9.6.3</b> added <b>Chapter 9.7:</b> Content improved <b>Chapter 9.7.8:</b> Descriptions improved and Footnote added Chapter 9.8 removed. Redundant information <b>Figure 35:</b> Content updated <b>Table 15</b> updated
BTS54040-LBA	Parameter P_5.3.26: Max. Value improved Parameter P_5.3.27: Max. Value improved Parameter P_6.6.26: Max. Value improved <b>Table 10</b> split into different tables <b>Table 10</b> to <b>Table 11:</b> Unit of $k_{iLIS}$ updated Parameter P_8.5.95: Max. Value improved Parameter P_8.5.96: Max. Value improved
<b>Rev. 1.0, 2013-03-24</b>	
All	Data Sheet released

**Trademarks of Infineon Technologies AG**

AURIX™, BlueMoon™, C166™, CanPAK™, CIPOS™, CIPURSE™, COMNEON™, EconoPACK™, CoolMOS™, CoolSET™, CORECONTROL™, CROSSAVE™, DAVE™, EasyPIM™, EconoBRIDGE™, EconoDUAL™, EconoPIM™, EiceDRIVER™, eupec™, FCOS™, HITFET™, HybridPACK™, I<sup>2</sup>RF™, ISOFACE™, IsoPACK™, MIPAQ™, ModSTACK™, my-d™, NovalithIC™, OmniTune™, OptiMOS™, ORIGA™, PRIMARION™, PrimePACK™, PrimeSTACK™, PRO-SIL™, PROFET™, RASIC™, ReverSave™, SatRIC™, SIEGET™, SINDRION™, SIPMOS™, SMARTi™, SmartLEWIS™, SOLID FLASH™, SPOC™, TEMPFET™, thinQ!™, TRENCHSTOP™, TriCore™, X-GOLD™, X-PMU™, XMM™, XPOSYS™.

**Other Trademarks**

Advance Design System™ (ADS) of Agilent Technologies, AMBA™, ARM™, MULTI-ICE™, KEIL™, PRIMECELL™, REALVIEW™, THUMB™,  $\mu$ Vision™ of ARM Limited, UK. AUTOSAR™ is licensed by AUTOSAR development partnership. Bluetooth™ of Bluetooth SIG Inc. CAT-iq™ of DECT Forum. COLOSSUS™, FirstGPS™ of Trimble Navigation Ltd. EMV™ of EMVCo, LLC (Visa Holdings Inc.). EPCOS™ of Epcos AG. FLEXGO™ of Microsoft Corporation. FlexRay™ is licensed by FlexRay Consortium. HYPERTERMINAL™ of Hilgraeve Incorporated. IEC™ of Commission Electrotechnique Internationale. IrDA™ of Infrared Data Association Corporation. ISO™ of INTERNATIONAL ORGANIZATION FOR STANDARDIZATION. MATLAB™ of MathWorks, Inc. MAXIM™ of Maxim Integrated Products, Inc. MICROTEC™, NUCLEUS™ of Mentor Graphics

Corporation. Mifare™ of NXP. MIPI™ of MIPI Alliance, Inc. MIPS™ of MIPS Technologies, Inc., USA. muRata™ of MURATA MANUFACTURING CO., MICROWAVE OFFICE™ (MWO) of Applied Wave Research Inc., OmniVision™ of OmniVision Technologies, Inc. Openwave™ Openwave Systems Inc. RED HAT™ Red Hat, Inc. RFMD™ RF Micro Devices, Inc. SIRIUS™ of Sirius Satellite Radio Inc. SOLARIS™ of Sun Microsystems, Inc. SPANSION™ of Spansion LLC Ltd. Symbian™ of Symbian Software Limited. TAIYO YUDEN™ of Taiyo Yuden Co. TEAKLITE™ of CEVA, Inc. TEKTRONIX™ of Tektronix Inc. TOKO™ of TOKO KABUSHIKI KAISHA TA. UNIX™ of X/Open Company Limited. VERILOG™, PALLADIUM™ of Cadence Design Systems, Inc. VLYNQ™ of Texas Instruments Incorporated. VXWORKS™, WIND RIVER™ of WIND RIVER SYSTEMS, INC. ZETEX™ of Diodes Zetex Limited.

Last Trademarks Update 2014-03-27

## Table of Contents

	<b>Table of Contents</b> .....	6
	<b>List of Figures</b> .....	8
	<b>List of Tables</b> .....	9
<b>1</b>	<b>Overview</b> .....	10
<b>2</b>	<b>Block Diagram</b> .....	12
2.1	Terms .....	13
<b>3</b>	<b>Pin Configuration</b> .....	14
3.1	Pin Assignment BTS54040-LBA .....	14
3.2	Pin Definitions and Functions .....	15
<b>4</b>	<b>Electrical Characteristics</b> .....	16
4.1	Absolute Maximum Ratings .....	16
4.2	Thermal Resistance .....	19
4.2.1	PCB Setup .....	19
4.2.2	Thermal Impedance .....	21
<b>5</b>	<b>Power Supply</b> .....	23
5.1	Operation modes .....	24
5.1.1	Power-up .....	25
5.1.2	Stand-by mode .....	25
5.1.3	Idle mode .....	25
5.1.4	Ready mode .....	26
5.1.5	Operative mode .....	26
5.1.6	Limp Home mode .....	26
5.2	Reset condition .....	26
5.2.1	Undervoltage on $V_S$ .....	27
5.3	Electrical Characteristics .....	28
<b>6</b>	<b>Power Stages</b> .....	30
6.1	Output ON-State Resistance .....	30
6.2	Input Circuit .....	30
6.3	Input Status Monitor .....	31
6.4	Power Stage Output .....	32
6.4.1	Bulb and LED Mode .....	32
6.4.2	Switching Resistive Loads .....	32
6.4.3	Switching Inductive Loads .....	33
6.4.4	Switching Channels in Parallel .....	33
6.5	Electrical Characteristics .....	34
<b>7</b>	<b>Protection Functions</b> .....	37
7.1	Over Load Protection .....	37
7.2	Over Temperature Protection .....	37
7.3	Reverse Polarity Protection .....	41
7.4	Over Voltage Protection .....	41
7.5	Loss of Ground .....	41
7.6	Loss of $V_S$ .....	41
7.7	Electrical Characteristics .....	42
<b>8</b>	<b>Diagnosis</b> .....	43
8.1	Diagnosis Word at SPI .....	44

**Table of Contents**

8.2	Load Current Sense Diagnosis .....	45
8.2.1	Current Sense Signal .....	45
8.2.2	Current Sense Multiplexer .....	45
8.2.3	Open Load at ON Diagnosis .....	46
8.3	Switch Bypass Monitor Diagnosis .....	46
8.4	Gate Back Regulation .....	47
8.5	Electrical Characteristics .....	48
<b>9</b>	<b>Serial Peripheral Interface (SPI) .....</b>	<b>52</b>
9.1	SPI Signal Description .....	52
9.2	Daisy Chain Capability .....	53
9.3	Timing Diagrams .....	54
9.4	Electrical Characteristics .....	55
9.5	SPI Protocol .....	57
9.6	SPI Diagnosis Registers .....	60
9.6.1	Standard Diagnosis .....	60
9.6.2	Errors Diagnosis .....	61
9.6.3	Warnings Diagnosis .....	61
9.7	SPI Configuration Registers .....	62
9.7.1	Output Configuration Register .....	62
9.7.2	Input Status Register .....	62
9.7.3	Swap Configuration Register .....	62
9.7.4	LED Mode Configuration Register .....	63
9.7.5	Gate Back Regulation Register .....	63
9.7.6	Hardware Configuration Register .....	63
9.7.7	Diagnosis Control Register .....	64
9.7.8	Configuration Register Bit Overview .....	64
<b>10</b>	<b>Application Description .....</b>	<b>66</b>
<b>11</b>	<b>Package Outlines BTS54040-LBA .....</b>	<b>68</b>

## List of Figures

Figure 1	Block Diagram BTS54040-LBA	12
Figure 2	Voltage and Current Definition	13
Figure 3	Pin Configuration TSON-24-8	14
Figure 4	2s2p PCB Cross Section	19
Figure 5	PC Board for Thermal Simulation with 600 mm <sup>2</sup> Cooling Area	20
Figure 6	PC Board for Thermal Simulation with 2s2p Cooling Area	20
Figure 7	Solder Area / Vias	21
Figure 8	Typical Thermal Impedance. PCB setup according <a href="#">Figure 6</a>	21
Figure 9	Typical Thermal Resistance. PCB setup 1s0p	22
Figure 10	Operation Mode state diagram	24
Figure 11	Limp Home Activation as function of $V_S$	26
Figure 12	$V_S$ undervoltage behavior	27
Figure 13	$R_{DS(ON)}$ variation factor	30
Figure 14	Input Switch Matrix	31
Figure 15	Power Stage Output	32
Figure 16	Switching a Load (resistive)	32
Figure 17	Typical Current Limitation variation according to $V_{DS}$ voltage	37
Figure 18	Dynamic Temperature Sensor Operations - Short Circuit	39
Figure 19	Dynamic and Absolute Temperature Sensor Operations - Overload Condition	40
Figure 20	Different counter reset according to <a href="#">HWCR.RCR</a> bit value	41
Figure 21	Block Diagram: Diagnosis	43
Figure 22	Current Sense Signal Timings	45
Figure 23	Current Sense Multiplexer Timings	46
Figure 24	Current Sense Ratio in Open Load at ON condition	46
Figure 25	Serial Peripheral Interface	52
Figure 26	Combinatorial Logic for TER Flag	52
Figure 27	Daisy Chain Configuration	53
Figure 28	Data Transfer in Daisy Chain Configuration	54
Figure 29	Timing Diagram SPI Access	54
Figure 30	Relationship between SI and SO during SPI communication	57
Figure 31	Register content sent back to $\mu C$	57
Figure 32	BTS54040-LBA response after an error in transmission	57
Figure 33	BTS54040-LBA response after coming out of Power-On reset at $V_{DD}$	58
Figure 34	BTS54040-LBA response in case of a negative battery voltage transient	58
Figure 35	Application Circuit Example	66
Figure 36	TSON-24-8 Package drawing	68
Figure 37	TSON-24 Package pads and stencil	69



## List of Tables

Table 1	Product Summary	10
Table 2	Absolute Maximum Ratings	16
Table 3	Thermal Resistance	19
Table 4	Device capability as function of $V_S$ and $V_{DD}$	23
Table 5	Device function in relation to operation modes, $V_S$ and $V_{DD}$ voltages	25
Table 6	Electrical Characteristics Power Supply	28
Table 7	Electrical Characteristics Power Stages	34
Table 8	Electrical Characteristics Protection Functions	42
Table 9	Operation Modes	44
Table 10	Electrical Characteristics Diagnosis $k_{ILIS}$ 39 mΩ ch.	48
Table 11	Electrical Characteristics Diagnosis	49
Table 12	Electrical Characteristics Serial Peripheral Interface (SPI)	55
Table 13	SPI Command Summary	59
Table 14	Register Overview	62
Table 15	Suggested Component Values	67



## 1 Overview

### Features

- 8-bit serial peripheral interface (daisy chain capable SPI) for control and diagnosis
- CMOS compatible parallel input pins for four channels
- Selectable AND- / OR-combination for parallel inputs (PWM control)
- Load type configuration via SPI (bulbs or LEDs) for optimized load control
- Very low stand-by current
- Device ground independent from load ground
- Green Product (RoHS-Compliant)
- AEC Qualified

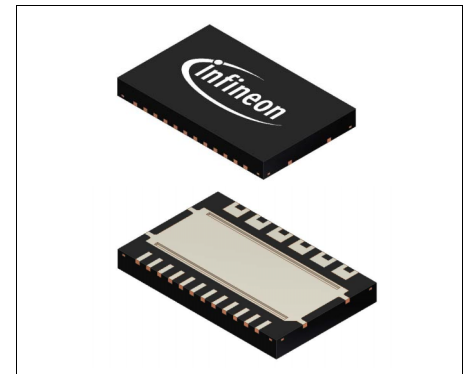
**TSON-24-8**

### Description

The BTS54040-LBA is a four channel high-side smart power switch in TSON-24-8 package providing embedded protective functions. It is specially designed to control standard exterior lighting in automotive applications. In order to use the same hardware, the device can be configured to bulb or LED mode. As a result, both load types are optimized in terms of switching and diagnosis behavior.

It is designed to drive exterior lamps up to 27 W or the equivalent LED light.

**Table 1 Product Summary**

Operating Voltage Power Switch	$V_S$	5.5 ... 28 V
Logic Supply Voltage	$V_{DD}$	3.8 ... 5.5 V
Over Voltage Protection	$V_{S(AZ,min)}$	42 V
Maximum Stand-By Current at 25 °C	$I_{VS(STB)}$	1 $\mu$ A
Maximum ON State Resistance at $T_j = 150$ °C 39 m $\Omega$ channels (Channel 1, 2, 3, 4)	$R_{DS(ON,max)}$	78 m $\Omega$
SPI Access Frequency	$f_{SCLK(max)}$	3 MHz

Configuration and status diagnosis are done via SPI. An 8-bit serial peripheral interface (SPI) is used. The SPI is daisy chain capable.

Type	Package	Marking
BTS54040-LBA	TSON-24-8	BTS54040-LBA

The device provides a current sense signal per channel that is multiplexed to the diagnosis pin IS. It can be enabled and disabled via SPI commands. An over temperature flag per output is provided in the SPI diagnosis word. A multiplexed switch bypass monitor provides short-circuit to  $V_S$  diagnosis.

39 m $\Omega$  channels can be configured to bulb or LED mode for maximum flexibility.

The BTS54040-LBA provides a fail-safe feature via a Limp Home Input (LHI) pin and direct Input pins.

The power transistors are built by N-channel vertical power MOSFETs with charge pumps. The device is monolithically integrated in SMART technology.

### Applications

- High-side power switch for 12 V in automotive or industrial applications such as lighting, heating, motor driving, energy and power distribution
- Especially designed for standard exterior lighting like position light, tail light, brake light, parking light, license plate light, indicators and equivalent in the LED technology
- Replaces electromechanical relays, fuses and discrete circuits

### Protective Functions

- Reverse battery protection with external components
- Short circuit to ground protection
- Stable behavior at under voltage
- Current limitation
- Absolute and dynamic temperature sensor
- Thermal shutdown with latch after a limited amount of retries
- Overvoltage protection
- Loss of ground protection
- Electrostatic discharge protection (ESD)

### Diagnostic Functions

- Multiplexed proportional load current sense signal (IS)
- Enable function for current sense signal configurable via SPI
- High accuracy of current sense signal at wide load current range
- Current sense ratio ( $k_{ILIS}$ ) configurable for LEDs or bulbs
- Very fast diagnosis in LED mode
- Feedback on over temperature via SPI
- Short circuit to  $V_S$  detection
- Monitoring of Input pins status

### Application Specific Functions

- Fail-safe activation via LHI pin and control via input pins
- Enhanced electromagnetic compatibility (EMC) for bulbs as well as LEDs
- LED mode selection available
- SPI with daisy chain capability
- Switch bypass monitoring for detecting short circuit to  $V_S$

## 2 Block Diagram

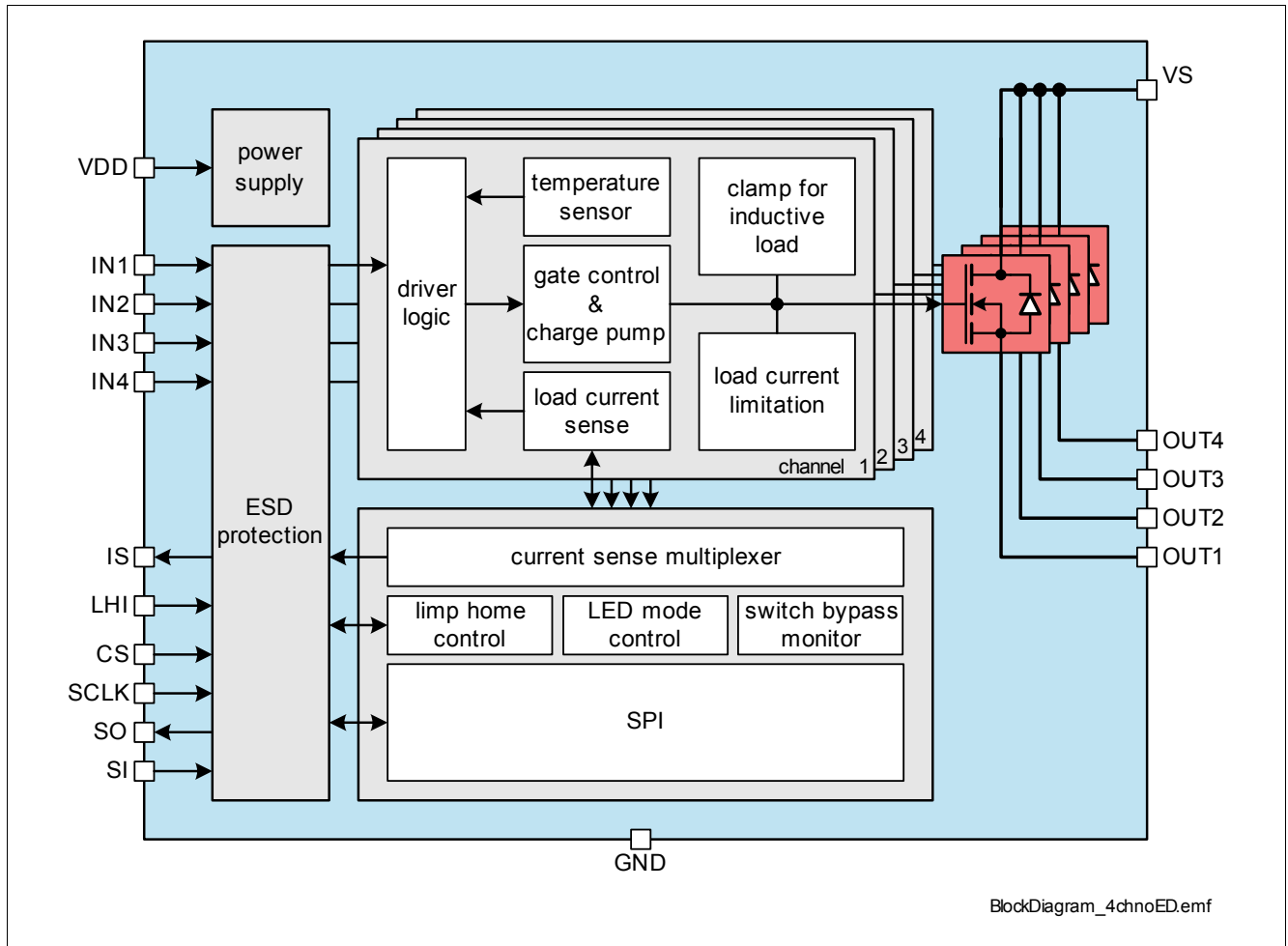
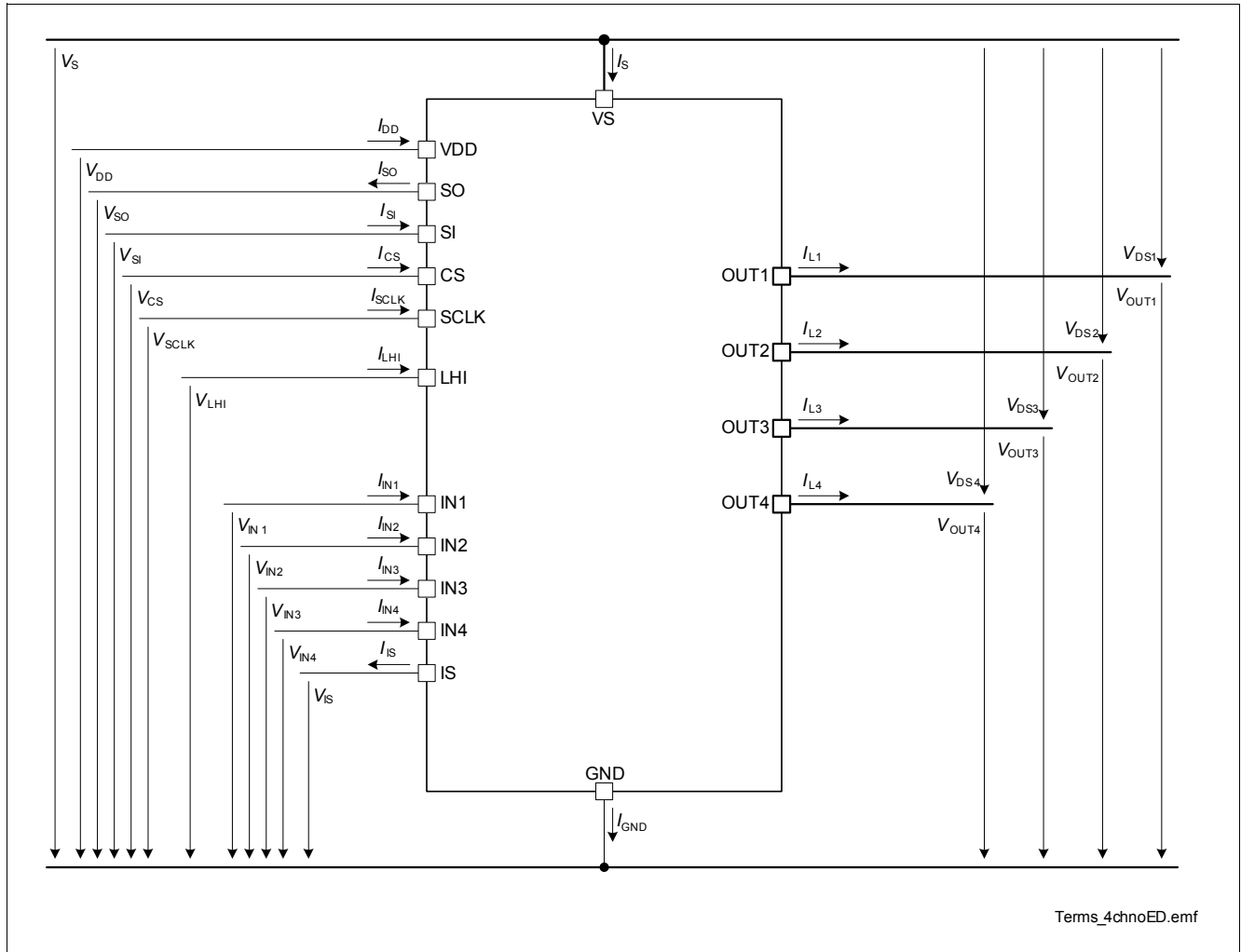

Figure 1 Block Diagram BTS54040-LBA

## 2.1 Terms

Figure 2 shows all terms used in this data sheet, with associated convention for positive values.



**Figure 2 Voltage and Current Definition**

In all tables of electrical characteristics, symbols related to channels without channel number are valid for each channel separately (e.g.  $V_{DS}$  specification is valid for  $V_{DS1} \dots V_{DS4}$ ).

All SPI register bits are marked as follows: ADDR.PARAMETER (e.g. **HWCR.STB**) with the exception of the bits in the Diagnosis frames which are marked only with PARAMETER (e.g. **VSMON**).

### 3 Pin Configuration

#### 3.1 Pin Assignment BTS54040-LBA

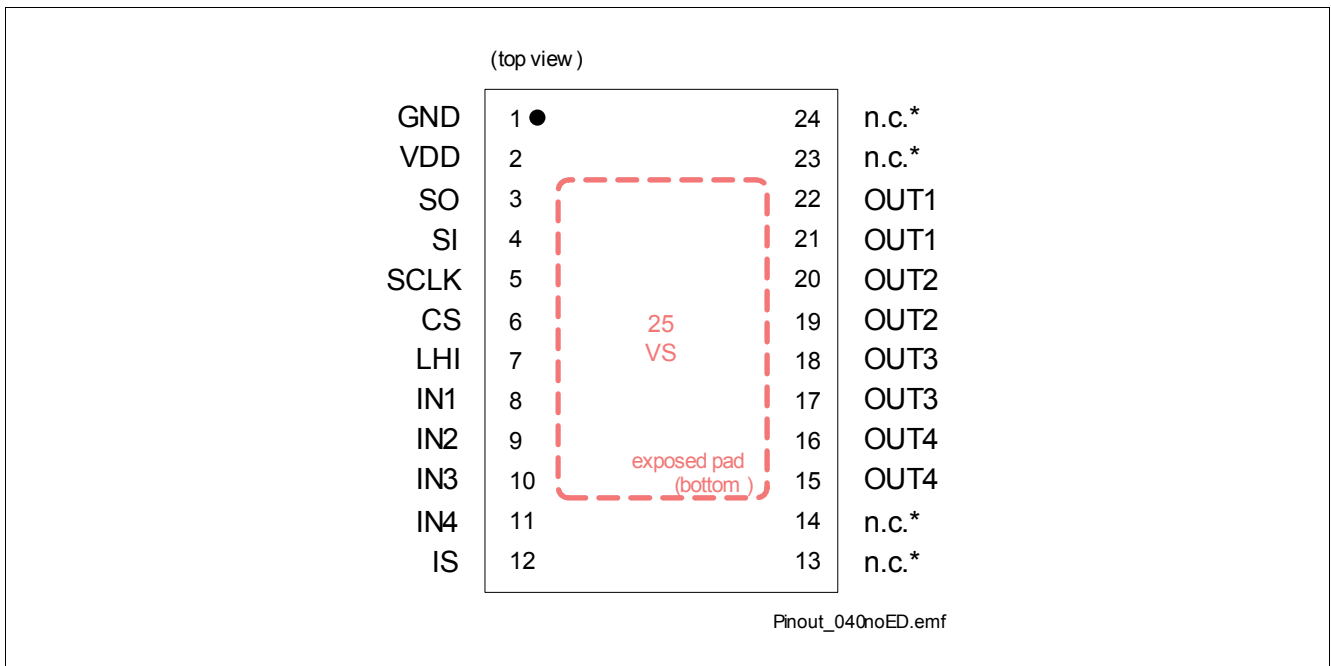

Figure 3 Pin Configuration TSON-24-8

### 3.2 Pin Definitions and Functions

Pin	Symbol	I/O	Function
<b>Power Supply Pins</b>			
25	VS	–	Positive power supply for high-side power switch
1	GND	–	Ground connection
2	VDD	–	Logic supply (5 V)
<b>SPI &amp; Diagnosis Pins</b>			
3	SO	O	Serial output of SPI interface
4	SI	I	Serial input of SPI interface (“high” active)
5	SCLK	I	Serial clock of SPI interface (“high” active)
6	CS	I	Chip select of SPI interface (“low” active); Integrated pull up to VDD
12	IS	O	Current sense output signal
<b>Limp Home Input Pin (integrated pull-down, leave unused Limp Home Input pin unconnected)</b>			
7	LHI	I	Limp home activation signal (“high” active)
<b>Parallel Input Pins (integrated pull-down, leave unused pins unconnected)</b>			
8	IN1	I	Input signal of channel 1 (“high” active)
9	IN2	I	Input signal of channel 2 (“high” active)
10	IN3	I	Input signal of channel 3 (“high” active)
11	IN4	I	Input signal of channel 4 (“high” active)
<b>Power Output Pins</b>			
21, 22 <sup>1)</sup>	OUT1	O	Protected high-side power output of channel 1
19, 20 <sup>1)</sup>	OUT2	O	Protected high-side power output of channel 2
17, 18 <sup>1)</sup>	OUT3	O	Protected high-side power output of channel 3
15, 16 <sup>1)</sup>	OUT4	O	Protected high-side power output of channel 4
<b>Not connected Pins</b>			
13, 14	n.c.*	–	Not connected, internally not bonded, shorted together
23, 24	n.c.*	–	Not connected, internally not bonded, shorted together

1) All outputs pins of each channel must be connected together on the PCB. All pins of an output are internally connected together. PCB traces have to be designed to withstand the maximum current which can flow.

## 4 Electrical Characteristics

### 4.1 Absolute Maximum Ratings

$T_j = -40$  to  $+150$  °C; all voltages with respect to ground

Typical resistive loads connected to the outputs (unless otherwise specified):

39 mΩ channels:  $R_L = 6.8$  Ω (33 Ω when **LGCR.LEDn** = "1")

**Table 2 Absolute Maximum Ratings<sup>1)</sup>**

Parameter	Symbol	Values			Unit	Note / Test Condition	Number
		Min.	Typ.	Max.			
<b>Supply Voltage</b>							
Power supply voltage	$V_S$	-0.3		28	V	–	P_4.1.1
Logic supply voltage	$V_{DD}$	-0.3		5.5	V	–	P_4.1.2
Reverse polarity voltage	$-V_{S(rev)}$	–		16	V	<sup>2)</sup> $T_{jStart} = 25$ °C $t \leq 2$ min. See <a href="#">Chapter 10</a> for setup	P_4.1.3
Supply voltage for short circuit protection (single pulse)	$V_{S(SC)}$	0		28	V	<sup>3)</sup> $R_{ECU} = 20$ mΩ $l = 0$ or 5 m $R_{Cable} = 16$ mΩ/m $L_{Cable} = 1$ μH/m	P_4.1.5
Permanent short circuit number channel activations All channels	$n_{RSC1}$	–		100	k	<sup>3)</sup> $V_{DD} = 5$ V $t_{ON} = 300$ ms	P_4.1.6
Voltage at power transistor	$V_{DS}$	–		42	V	–	P_4.1.8
Supply voltage for load dump protection	$V_{S(LD)}$	–		42	V	<sup>4)</sup> $R_l = 2$ Ω $t = 400$ ms	P_4.1.9
Current through ground pin	$I_{GND}$	-100		25	mA	$t \leq 2$ min.	P_4.1.10
Current through VDD pin	$I_{DD}$	-25		30	mA	$t \leq 2$ min.	P_4.1.11
<b>Power Stages</b>							
Load current	$ I_L $	–		$I_{L(LIM)}$	A	<sup>5)</sup>	P_4.1.12
Maximum energy dissipation single pulse - 39 mΩ ch.	$E_{AS}$	–		45	mJ	<sup>6)</sup> $T_{j(0)} = 150$ °C $I_{L(0)} = I_{L(nom)}$ P_6.6.17	P_4.1.15
<b>Diagnosis Pin</b>							
Voltage at sense pin IS	$V_{IS}$	-0.3		$V_S$	V	–	P_4.1.24
Current through sense pin IS	$I_{IS}$	-10		40	mA	$t \leq 2$ min.	P_4.1.25
<b>Input Pins</b>							



**Table 2 Absolute Maximum Ratings<sup>1)</sup> (cont'd)**

Parameter	Symbol	Values			Unit	Note / Test Condition	Number
		Min.	Typ.	Max.			
Voltage at input pins	$V_{IN}$	-0.3		6.0	V	–	P_4.1.26
Current through input pins	$I_{IN}$	-0.75		0.75	mA	–	P_4.1.27
Current through input pins	$I_{IN}$	-2.0		10	mA	$t \leq 2$ min.	P_4.1.28
<b>SPI Pins</b>							
Voltage at chip select pin	$V_{CS}$	-0.3		6.0	V	–	P_4.1.29
Current through chip select pin	$I_{CS}$	-0.75		0.75	mA	–	P_4.1.30
Current through chip select pin	$I_{CS}$	-2.0		10	mA	$t \leq 2$ min.	P_4.1.31
Voltage at serial input pin	$V_{SI}$	-0.3		6.0	V	–	P_4.1.32
Current through serial input pin	$I_{SI}$	-0.75		0.75	mA	–	P_4.1.33
Current through serial input pin	$I_{SI}$	-2.0		10	mA	$t \leq 2$ min.	P_4.1.34
Voltage at serial clock pin	$V_{SCLK}$	-0.3		6.0	V	–	P_4.1.35
Current through serial clock pin	$I_{SCLK}$	-0.75		0.75	mA	–	P_4.1.36
Current through serial clock pin	$I_{SCLK}$	-2.0		10	mA	$t \leq 2$ min.	P_4.1.37
Current through serial output pin SO	$I_{SO}$	-0.75		0.75	mA	–	P_4.1.38
Current through serial output pin SO	$I_{SO}$	-10		2.0	mA	$t \leq 2$ min.	P_4.1.39
<b>Limp Home Input Pin</b>							
Voltage at Limp Home Input pin	$V_{LHI}$	-0.3		6.0	V	–	P_4.1.40
Current through Limp Home Input pin	$I_{LHI}$	-0.75		0.75	mA	–	P_4.1.41
Current through Limp Home Input pin	$I_{LHI}$	-2.0		10	mA	$t \leq 2$ min.	P_4.1.42
<b>Temperatures</b>							
Junction temperature	$T_j$	-40		150	°C	–	P_4.1.45
Dynamic temperature increase while switching	$\Delta T_j$	–		60	K	–	P_4.1.46
Storage temperature	$T_{stg}$	-55		150	°C	–	P_4.1.47
<b>ESD Susceptibility</b>							
ESD susceptibility HBM OUT pins vs. VS	$V_{ESD}$	-4		4	kV	<sup>7)</sup> HBM	P_4.1.48
ESD susceptibility HBM all pins vs. VDD	$V_{ESD}$	-1.5		1.5	kV	<sup>7)</sup> HBM	P_4.1.54
ESD susceptibility HBM other pins vs. GND incl. OUT pins vs. GND	$V_{ESD}$	-2		2	kV	<sup>7)</sup> HBM	P_4.1.49
ESD Resistivity to GND	$V_{ESD}$	-500		500	V	<sup>8)</sup> CDM	P_4.1.51
ESD Resistivity Pin 1, 12, 13, 24 (corner pins) to GND	$V_{ESD1, 12, 13, 24}$	-750		750	V	<sup>8)</sup> CDM	P_4.1.52

1) Not subject to production test, specified by design.

2) Device is mounted on an FR4 2s2p board according to Jedec JESD51-2,-5,-7 at natural convection; The product (chip and package) was simulated on a 76.4 \* 114.3 \* 1.5 mm board with 2 inner copper layers (2 \* 70  $\mu$ m Cu, 2 \* 35  $\mu$ m Cu). Where applicable, a thermal via array under the package contacted the first inner copper layer.

---

**Electrical Characteristics**

- 3) EOL tests according to AECQ100-012. Threshold limit for short circuit failures: 100 ppm. Please refer to the legal disclaimer for short-circuit capability at the end of this document.
- 4)  $R_i$  is the internal resistance of the load dump pulse generator.
- 5) Current limitation is a protection feature. Protection features are not designed for continuous repetitive operation.
- 6) Pulse shape represents inductive switch OFF:  $I_{D(t)} = I_D(t) \times (1 - t / t_{\text{pulse}})$ ;  $0 < t < t_{\text{pulse}}$
- 7) ESD resistivity, HBM according to ANSI/ESDA/JEDEC JS-001-2010
- 8) ESD susceptibility, Charged Device Model "CDM" EIA/JESD22-C101 or ESDA STM5.3.1

**Notes**

1. *Stresses above the ones listed here may cause permanent damage to the device. Exposure to absolute maximum rating conditions for extended periods may affect device reliability.*
2. *Integrated protection functions are designed to prevent IC destruction under fault conditions described in the data sheet. Fault conditions are considered as "outside" normal operating range. Protection functions are not designed for continuous repetitive operation.*

## 4.2 Thermal Resistance

Note: This thermal data was generated in accordance with JEDEC JESD51 standards. For more information, go to [www.jedec.org](http://www.jedec.org).

**Table 3 Thermal Resistance**

Parameter	Symbol	Values			Unit	Note / Test Condition	Number
		Min.	Typ.	Max.			
Junction to Soldering Point	$R_{thJSP}$	–	2	–	K/W	<sup>1)</sup> $T_{j(0)} = 105\text{ °C}$ measured to pin 25	P_4.2.1
Junction to Ambient	$R_{thJA}$	–	21	–	K/W	<sup>1)2)</sup> $T_{j(0)} = 105\text{ °C}$	P_4.2.2

1) Not subject to production test, specified by design.

2) Specified  $R_{thJA}$  values is according to Jecdec JESD51-2,-5,-7 at natural convection on FR4 2s2p board; The product (chip and package) was simulated on a 76.4 \* 114.3 \* 1.5 mm board with 2 inner copper layers (2 \* 70  $\mu\text{m}$  Cu, 2 \* 35  $\mu\text{m}$  Cu). Where applicable, a thermal via array under the package contacted the first inner copper layer.

### 4.2.1 PCB Setup

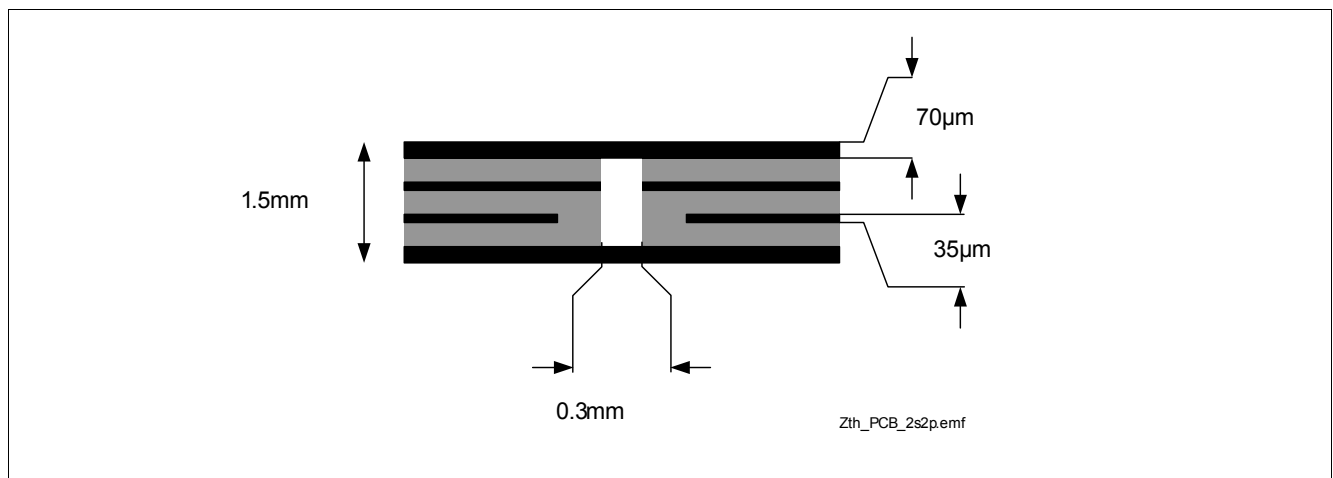

**Figure 4 2s2p PCB Cross Section**

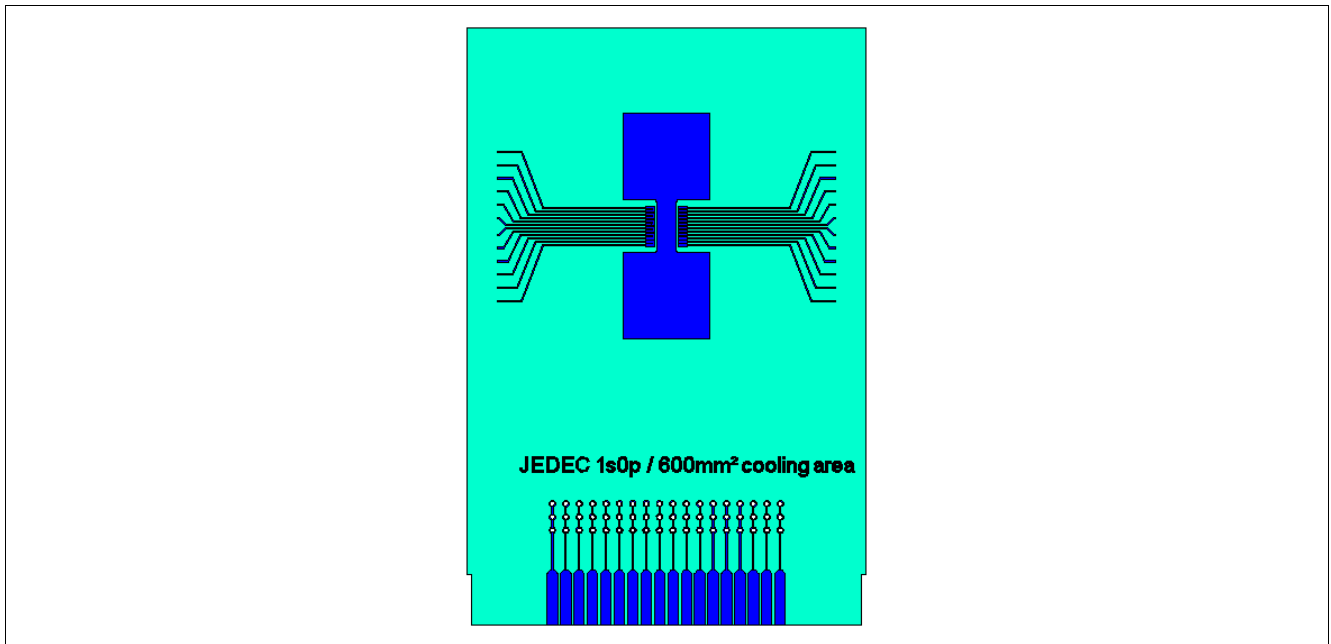

Figure 5 PC Board for Thermal Simulation with 600 mm<sup>2</sup> Cooling Area

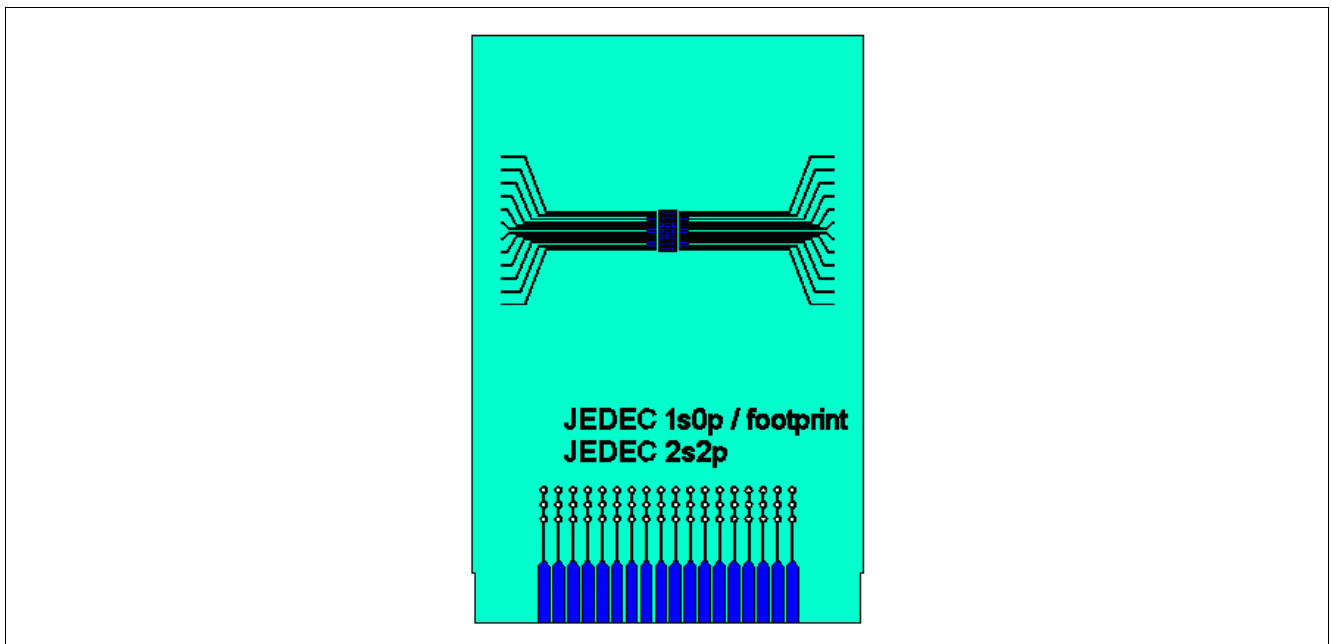

Figure 6 PC Board for Thermal Simulation with 2s2p Cooling Area

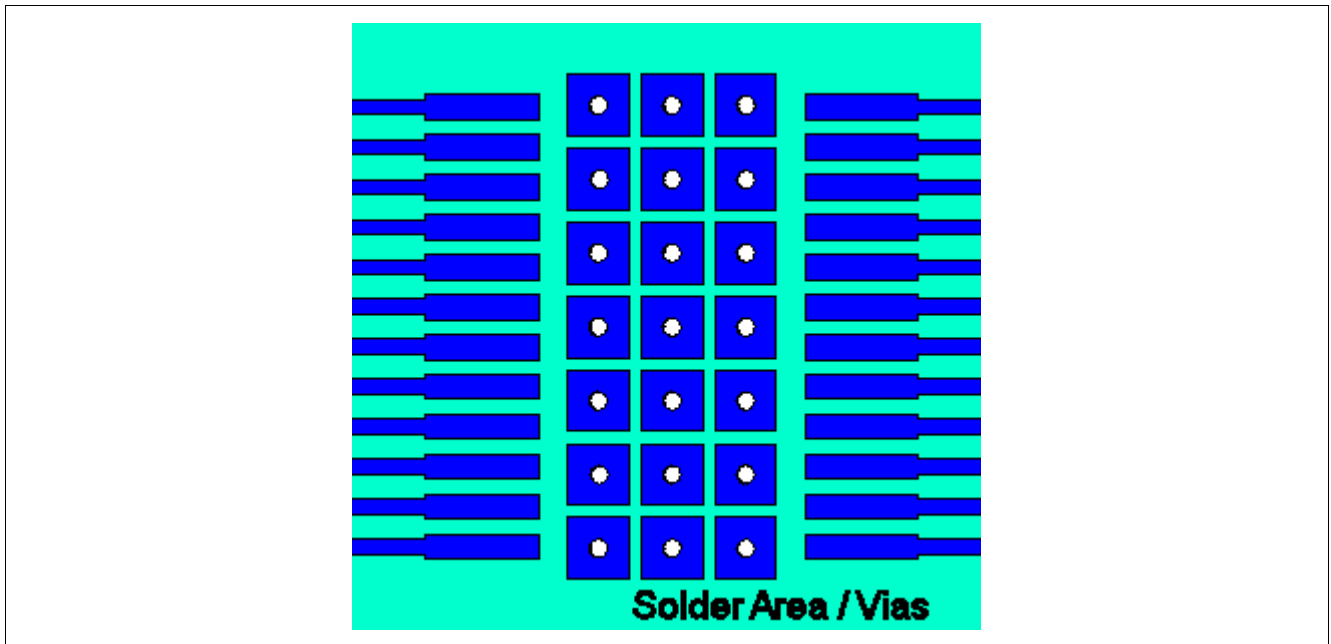

Figure 7 Solder Area / Vias

#### 4.2.2 Thermal Impedance

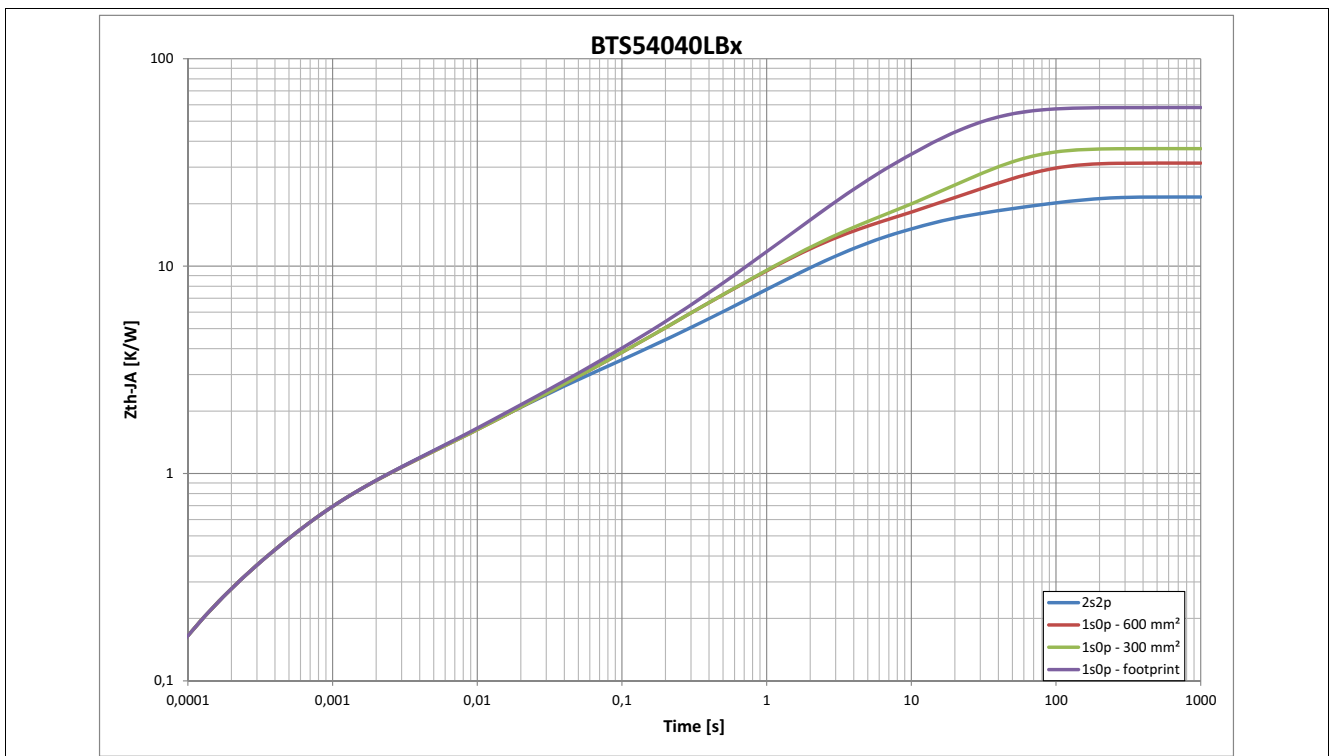

Figure 8 Typical Thermal Impedance. PCB setup according Figure 6

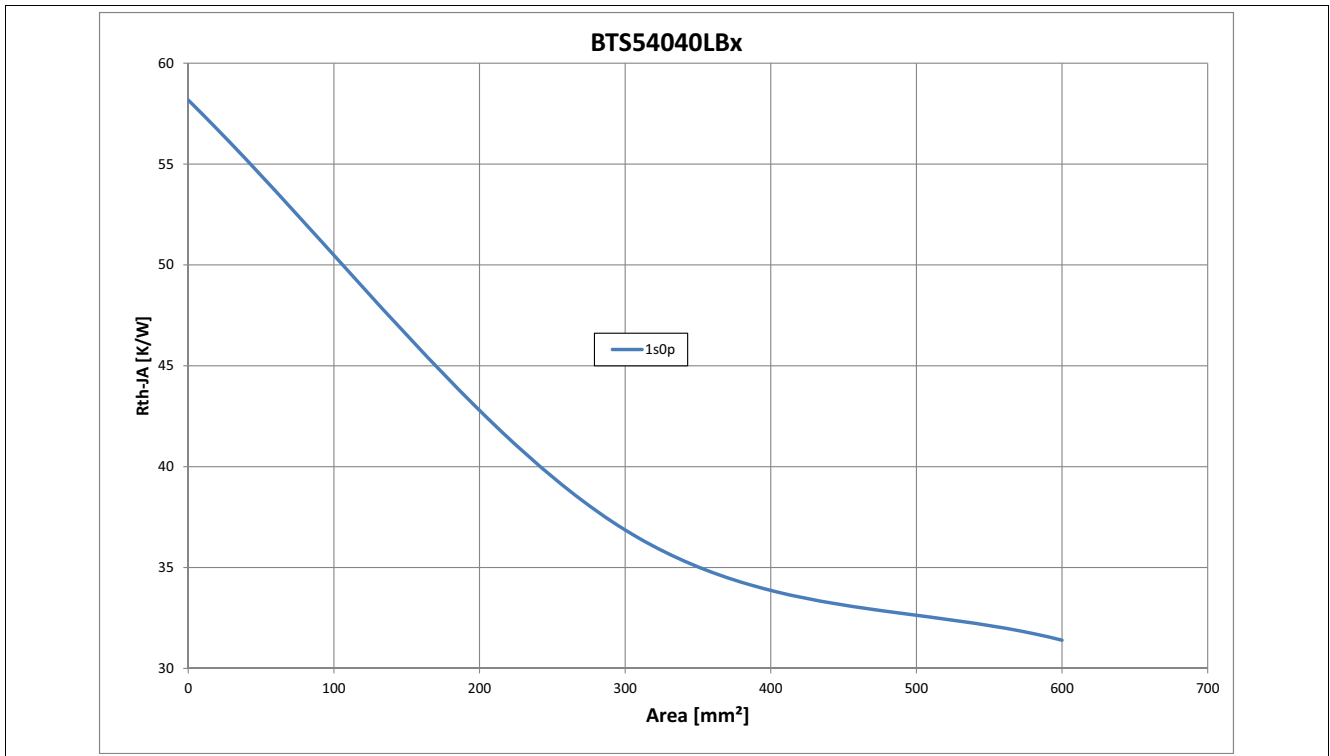

Figure 9 Typical Thermal Resistance. PCB setup 1s0p

## 5 Power Supply

The BTS54040-LBA is supplied by two voltage sources:

- $V_S$  (analog supply voltage)
- $V_{DD}$  (digital supply voltage)

The  $V_S$  supply line is connected to a battery feed and used for the driving circuitry of the power stages, while  $V_{DD}$  is used for the SPI logic and for driving SO pin.

$V_S$  and  $V_{DD}$  supply voltages have an undervoltage detection circuit, which prevents the activation of the associated function in case the measured voltage is below the undervoltage threshold. More in detail:

- An undervoltage on  $V_{DD}$  supply prevents SPI communication. SPI registers are reset to default values. The retry counters used to protect the channels are reset therefore the channels are in “unlimited restart” mode.
- An undervoltage on  $V_S$  supply switches OFF all channels, even in Limp Home mode. The channels are enabled again as soon as  $V_S = V_{S(OP)}$ .

The voltage at pin VS is also monitored. In case of a negative voltage transient resulting in  $V_S < V_{SMON}$  with  $DCR.MUX \neq "111_B"$ , any SPI command sent by the micro-controller is not accepted (see [Chapter 9.5](#) for further details).

An overview of channel behavior according to different  $V_S$  and  $V_{DD}$  supply voltages is shown in [Table 4](#) (the table is valid after a successful supply voltage ramp-up).

**Table 4** Device capability as function of  $V_S$  and  $V_{DD}$

	$V_{DD} \leq V_{DD(PO)}$ ( $V_{DD(PO)} = P\_5.3.17$ )	$V_{DD} > V_{DD(PO)}$
$V_S \leq V_{SMON}$ ( $V_{SMON} = P\_5.3.12$ )	Channels are OFF	Channels are OFF
	SPI registers reset	SPI registers protected <sup>1)</sup>
	SPI communication not available ( $f_{SCLK} = 0$ MHz)	SPI communication available <sup>2)</sup> ( $f_{SCLK} = 3$ MHz)
	Limp Home mode not available	Limp Home mode not available
$V_{SMON} < V_S \leq V_{S(UV)}$ ( $V_{S(UV)} = P\_5.3.2$ )	Channels are OFF	Channels are OFF
	SPI registers reset	SPI registers available
	SPI communication not available ( $f_{SCLK} = 0$ MHz)	SPI communication available ( $f_{SCLK} = 3$ MHz)
	Limp Home mode available (channels are OFF)	Limp Home mode available (channels are OFF)
$V_S > V_{S(UV)}$ <sup>3)</sup>	Channels cannot be controlled by SPI	Channels can be switched ON and OFF
	SPI registers reset	SPI registers available
	SPI communication not available ( $f_{SCLK} = 0$ MHz)	SPI communication available ( $f_{SCLK} = 3$ MHz)
	Limp Home mode available	Limp Home mode available

1) If  $DCR.MUX \neq 111_B$ , otherwise SPI registers are available.

2) SPI response depends on  $DCR.MUX$  value. See [Chapter 9.5](#) for further details.

3) The undervoltage condition on  $V_S$  supply must be considered. See [Chapter 5.2.1](#) for further details.

### 5.1 Operation modes

BTS54040-LBA has the following operation modes:

- Stand-by mode
- Idle mode
- Ready mode
- Operative mode
- Limp Home mode

The transition between operation modes is determined according to these variables:

- logic level at LHI pin
- logic level at INn pins
- **DCR.MUX** bits state
- **OUT.OUTn** bits state

The state diagram including the possible transitions is shown in **Figure 10**. The behavior of BTS54040-LBA as well as some parameters may change in dependence from the operation mode of the device. Furthermore, due to the undervoltage detection circuitry which monitors  $V_S$  and  $V_{DD}$  supply voltages, some changes within the same operation mode can be seen accordingly.

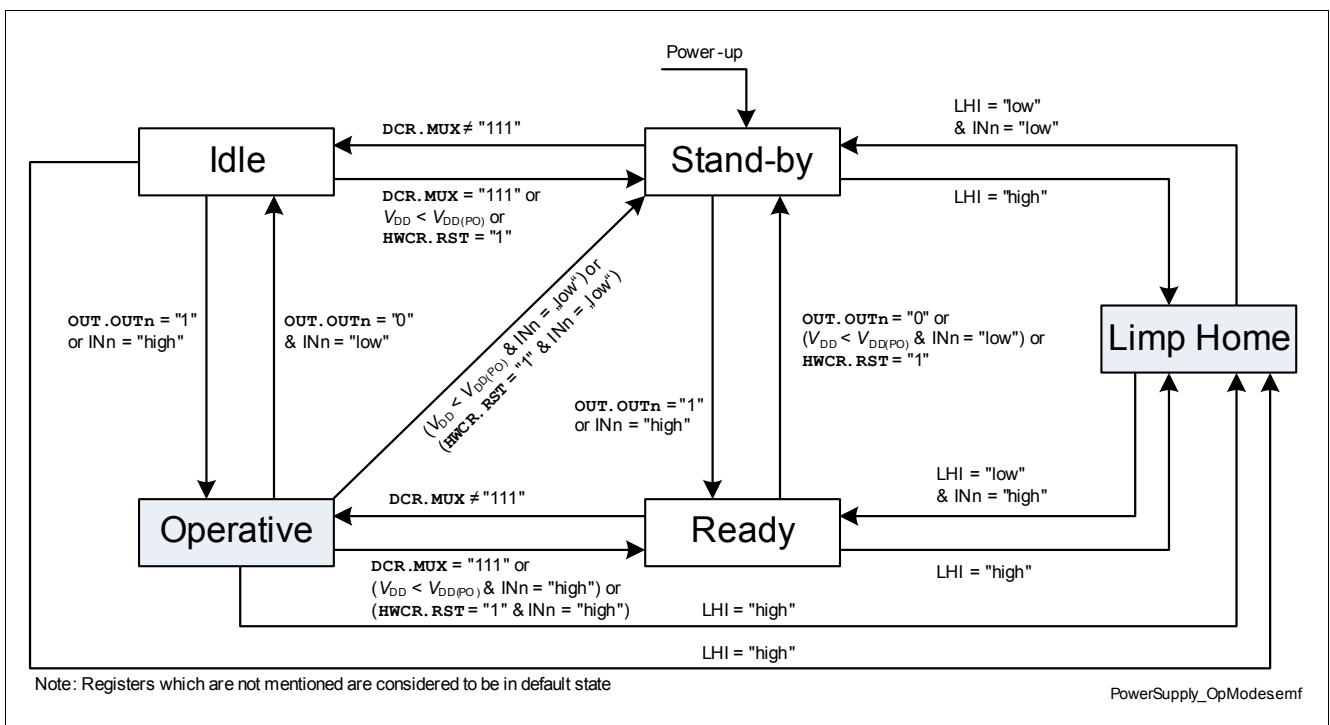

**Figure 10 Operation Mode state diagram**

There are three parameters describing the behavior of BTS54040-LBA:

- status of output channels
- status of SPI registers
- status of SPI communication

It is necessary to set **DCR.MUX** to a value different from 111<sub>B</sub> to command a switch ON of one or more channels. In alternative it is necessary to set the LHI to "high" - in this case the logic state of the Input pins is reflected to the outputs (if there is no undervoltage condition on  $V_S$  supply).



**Table 5** shows the correlation between device operation modes,  $V_S$  and  $V_{DD}$  supply voltages, and the state of the most important functions (channel status, SPI communication and SPI registers).

**Table 5 Device function in relation to operation modes,  $V_S$  and  $V_{DD}$  voltages**

Operation Mode	Function	$V_S \leq V_{SMON}$	$V_{SMON} > V_S \leq V_{S(UV)}$	$V_S > V_{S(UV)}$
Stand-by	Channels	OFF	OFF	OFF
	SPI comm.	available <sup>1)</sup>	available <sup>1)</sup>	available <sup>1)</sup>
	SPI registers	available <sup>1)</sup>	available <sup>1)</sup>	available <sup>1)</sup>
Idle	Channels	OFF	OFF	OFF
	SPI comm.	all commands rejected <sup>1)</sup>	available <sup>1)</sup>	available <sup>1)</sup>
	SPI registers	available <sup>1)</sup>	available <sup>1)</sup>	available <sup>1)</sup>
Ready	Channels	OFF	OFF	OFF
	SPI comm.	available <sup>1)</sup>	available <sup>1)</sup>	available <sup>1)</sup>
	SPI registers	available <sup>1)</sup>	available <sup>1)</sup>	available <sup>1)</sup>
Operative	Channels	OFF	OFF	follow <b>OUT.OUTn</b> and/or Input pins
	SPI comm.	all commands rejected <sup>1)</sup>	available <sup>1)</sup>	available <sup>1)</sup>
	SPI registers	available <sup>1)</sup>	available <sup>1)</sup>	available <sup>1)</sup>
Limp Home	Channels	OFF	OFF	follow Input pins
	SPI comm.	available (read-only) <sup>1)2)</sup>	available (read-only) <sup>1)2)</sup>	available (read-only) <sup>1)2)</sup>
	SPI registers	reset	reset	reset

1) If  $V_{DD} > V_{DD(PO)}$ , otherwise not available or in reset.

2) **HWCR.CTC** and **HWCR.RST** commands are accepted.

### 5.1.1 Power-up

The Power-up condition is entered when one of the supply voltages ( $V_S$  or  $V_{DD}$ ) is applied to the device. Both supplies are rising until they are above the undervoltage thresholds  $V_{S(OP)}$  and  $V_{DD(PO)}$  therefore the internal power-on signals are set.

### 5.1.2 Stand-by mode

When BTS54040-LBA is in Stand-by mode, all outputs are OFF. The SPI registers can be programmed if  $V_{DD} > V_{DD(PO)}$ . The current consumption is minimum (see parameter  $I_{VS(STB)}$ ). The circuitry that monitors  $V_S$  versus the threshold  $V_{SMON}$  is disabled, allowing the programming of the registers. Even if one Input pin is set to "high" or if one **OUT.OUTn** bit is set to "1", all outputs stay switched OFF.

### 5.1.3 Idle mode

In Idle mode, the internal supply circuitry is working and the device current consumption is increased. All channels are OFF and a command to switch ON one or more outputs (either via SPI or via Input pins) is accepted and executed, bringing the device into Operative mode.

### 5.1.4 Ready mode

In Ready mode, one or more outputs received a command to switch ON (either via SPI or via Input pins). Nevertheless all outputs are OFF because of **DCR.MUX** bits still set to 111<sub>B</sub>. It is necessary to change the value of those bits to bring the device into Operative mode and switch ON the channels.

### 5.1.5 Operative mode

Operative mode is the normal operation mode of BTS54040-LBA when no Limp Home condition is set and one or more outputs are switched ON. Device current consumption is specified by parameter  $I_{GND}$ . An undervoltage condition on  $V_{DD}$  supply voltage brings the device into Stand-by mode (if all Input pins are set to “low”) or into Ready mode (if at least one Input pin is set to “high”).

### 5.1.6 Limp Home mode

BTS54040-LBA enters Limp Home mode when LHI pin is set to “high”. SPI registers are reset to the default values after  $t_{LHI(ac)}$  from the rising edge at pin LHI (see **Figure 11** for further details). SPI communication is possible but only in read-only mode (SPI registers can be read but cannot be written, meaning that current sensing is not available). When  $V_S \leq V_{SMON}$  and **DCR.MUX**  $\neq$  111<sub>B</sub> the logic state detected at pin LHI is ignored and the device doesn't enter Limp Home mode.

*Note: The only write commands excepted in Limp Home mode are **HWCR.CTC** and **HWCR.RST** to clear the protection latches.*

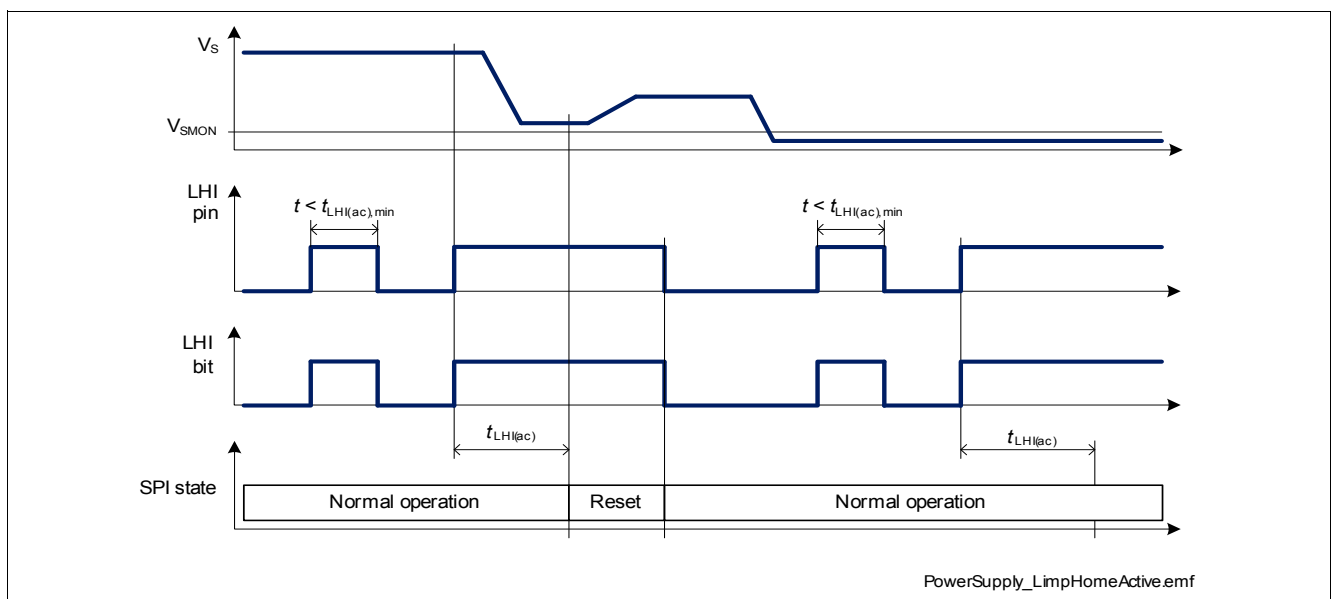

**Figure 11 Limp Home Activation as function of  $V_S$**

## 5.2 Reset condition

One of the following 3 conditions resets the SPI registers to their default values:

- $V_{DD}$  is not present or below the undervoltage threshold  $V_{DD(PO)}$
- LHI pin is set to “high” and  $V_S > V_{SMON}$
- a reset command (**HWCR.RST** = 1<sub>B</sub>) is executed

In particular, all channels are switched OFF (if the device is not in Limp Home mode with one or more Input pins set to “high”). In case of lack of  $V_{DD}$  supply the internal retry counters are disabled therefore all channels are in “unlimited restart” mode.

### 5.2.1 Undervoltage on $V_S$

Between  $V_{S(OP)}$  and  $V_{S(UV)}$  the undervoltage mechanism is triggered. If the device is operative and the supply voltage drops below the undervoltage threshold  $V_{S(UV)}$ , the logic switches OFF the channels. As soon as the supply voltage  $V_S$  is above the minimum operative voltage threshold  $V_{S(OP)}$ , the channels having either the corresponding Input pin set to “high” or the `OUT.OUTn` bit set to “1” are switched ON again (as shown in Figure 12).

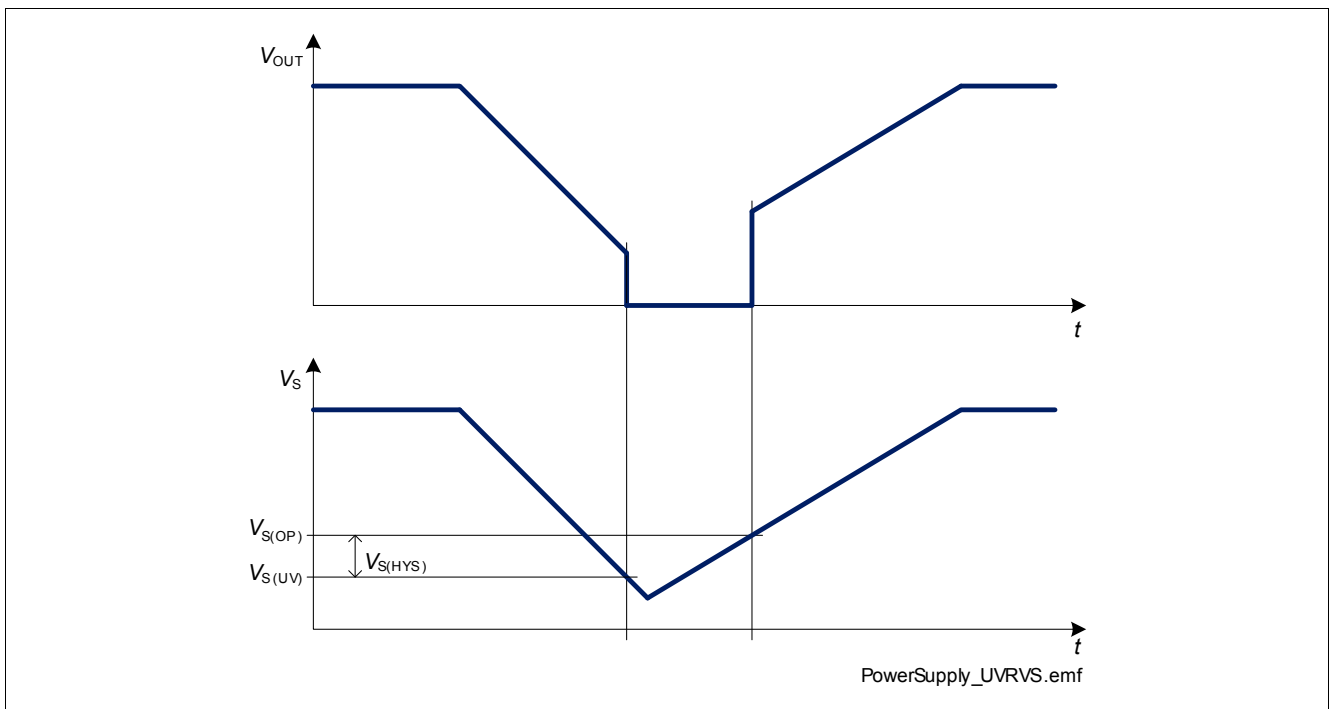

Figure 12  $V_S$  undervoltage behavior

### 5.3 Electrical Characteristics

Unless otherwise specified:  $V_S = 7\text{ V to }18\text{ V}$ ,  $V_{DD} = 3.8\text{ V to }5.5\text{ V}$ ,  $T_j = -40\text{ °C to }+150\text{ °C}$

Typical values:  $V_S = 13.5\text{ V}$ ,  $V_{DD} = 4.3\text{ V}$ ,  $T_j = 25\text{ °C}$

Typical resistive loads connected to the outputs (unless otherwise specified):

39 mΩ channels:  $R_L = 6.8\text{ Ω}$  (33 Ω when **LGCR.LEDn** = "1")

**Table 6 Electrical Characteristics Power Supply**

Parameter	Symbol	Values			Unit	Note / Test Condition	Number
		Min.	Typ.	Max.			
<b>VS pin</b>							
Operating voltage power switch	$V_{S(OP)}$	5.5	–	28 <sup>1)</sup>	V	$V_{DS} < 0.5\text{ V}$	P_5.3.1
Undervoltage shutdown	$V_{S(UV)}$	–	–	4.5	V	OUTn = ON From $V_{DS} < 1\text{ V}$ to $I_{Ln} = 0\text{ A}$ (see <a href="#">Figure 12</a> )	P_5.3.2
Undervoltage shutdown Hysteresis	$V_{S(HYS)}$	–	350	–	mV	<sup>1)</sup>	P_5.3.3
Stand-by current for whole device with loads	$I_{VS(STB)}$	–	0.1	1	μA	<sup>1)</sup> $V_{DD} = 0\text{ V}$ $V_{LHI} = 0\text{ V}$ $T_j = 25\text{ °C}$	P_5.3.7
Stand-by current for whole device with loads	$I_{VS(STB)}$	–	0.1	2.5	μA	<sup>1)</sup> $V_{DD} = 0\text{ V}$ $V_{LHI} = 0\text{ V}$ $T_j = 85\text{ °C}$	P_5.3.8
Stand-by current for whole device with loads	$I_{VS(STB)}$	–	4	15	μA	$V_{DD} = 0\text{ V}$ $V_{LHI} = 0\text{ V}$ $T_j = 150\text{ °C}$	P_5.3.26
Idle current for whole device with loads, all channels OFF	$I_{VS(idle)}$	–	2.25	5	mA	$V_{DD} = 5\text{ V}$ <b>DCR.MUX</b> = 110 <sub>B</sub>	P_5.3.10
Operating current for whole device	$I_{GND}$	–	7	14	mA	$f_{SCLK} = 0\text{ MHz}$	P_5.3.27
$V_S$ threshold for Limp Home validation	$V_{SMON}$	0.6	1.2	1.8	V	<b>VSMON</b> = 1	P_5.3.12
<b>VDD pin</b>							
Logic supply voltage	$V_{DD}$	3.8	–	5.5 <sup>1)</sup>	V	$f_{SCLK} = 3\text{ MHz}$	P_5.3.13
Logic supply current Normal operation	$I_{DD}$	–	125	220	μA	$f_{SCLK} = 0\text{ MHz}$ $V_{CS} = V_{DD} = 5\text{ V}$ <b>DCR.MUX</b> ≠ 111 <sub>B</sub>	P_5.3.14
Logic Stand-by current	$I_{DD(STB)}$	–	35	70	μA	$f_{SCLK} = 0\text{ MHz}$ $V_{CS} = V_{DD} = 5\text{ V}$ <b>DCR.MUX</b> = 111 <sub>B</sub>	P_5.3.16

**Table 6 Electrical Characteristics Power Supply (cont'd)**

Parameter	Symbol	Values			Unit	Note / Test Condition	Number
		Min.	Typ.	Max.			
Power-On reset threshold voltage	$V_{DD(PO)}$	2.3	2.75	3.8	V	SI = 0 V SCLK = 0 V CS = 0 V SO from 0 to Z	P_5.3.17
<b>LHI Input Characteristics</b>							
L-input level at pin LHI	$V_{LHI(L)}$	-0.3	–	1.0	V	LHI = 1 (see Chapter 9.6.1)	P_5.3.18
H-input level at pin LHI	$V_{LHI(H)}$	2.6	–	6.0	V	–	P_5.3.19
L-input current through pin LHI	$I_{LHI(L)}$	3	27	75	μA	$V_{LHI} = 1.0\text{ V}$	P_5.3.20
H-input current through pin LHI	$I_{LHI(H)}$	7	30	75	μA	$V_{LHI} = 2.6\text{ V}$	P_5.3.21
<b>Timings</b>							
Power-On wake up time	$t_{WU(PO)}$	–	200	–	μs	<sup>1)</sup>	P_5.3.22
Limp Home acknowledgement time	$t_{LHI(ac)}$	5	–	30	μs	$V_{DD} = 5\text{ V}$ polling of Standard Diagnosis (see Chapter 9.6.1) until LHI = STB = 1	P_5.3.23
Reset command delay time	$t_{d(RST)}$	–	–	100	μs	<sup>1)</sup>	P_5.3.25

1) Not subject to production test, specified by design.

Note: Characteristics show the deviation of parameter at the given supply voltage and junction temperature.

Typical values show the typical parameters expected from manufacturing at  $V_S = 13.5\text{ V}$ ,  $V_{DD} = 4.3\text{ V}$  and  $T_j = 25\text{ °C}$

## 6 Power Stages

The high-side power stages are built by N-channel vertical power MOSFETs with charge pumps. There are four channels implemented in the device. Each channel can be switched on via SPI register `OUT` or via an input pin, when available. All channels provide a load type configuration for bulbs or LEDs in register `LGCR` (see [Chapter 9.7.4](#)). The load type configuration can be changed in ON- as well as in OFF-state.

### 6.1 Output ON-State Resistance

The ON-state resistance  $R_{DS(ON)}$  depends mainly on the junction temperature  $T_j$ . [Figure 13](#) shows the variation of  $R_{DS(ON)}$  across the whole temperature range. The value "1" corresponds to the typical  $R_{DS(ON)}$  measured at  $T_j = 25^\circ\text{C}$ .

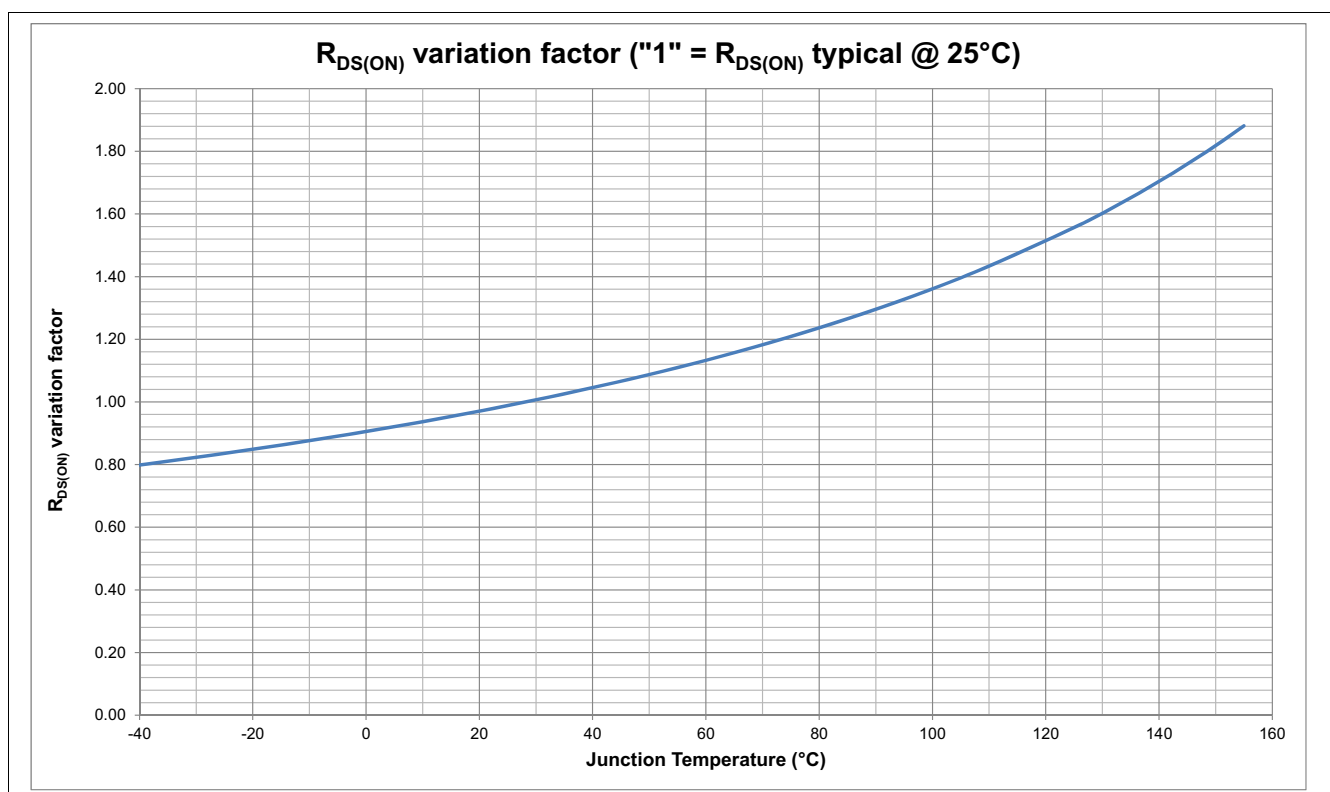

**Figure 13**  $R_{DS(ON)}$  variation factor

The behavior in reverse polarity mode is described in [Chapter 7](#).

### 6.2 Input Circuit

There are two ways of using the input pins in combination with the register `OUT` by programming bit `HWCR.COL` in register `HWCR` (see [Chapter 9.7.6](#)).

- `HWCR.COL = 0`: A channel is switched ON either by the according `OUT.OUTn` bit or by the input pin.
- `HWCR.COL = 1`: A channel is switched ON by the according `OUT.OUTn` bit only, when the input pin is "high". In this configuration, a PWM signal can be applied to the input pin and the channel is activated by the SPI register `OUT` (see [Chapter 9.7.1](#)).

The default state (`HWCR.COL = 0`) is the OR-combination of the input signal and the SPI-bit. In Limp Home Mode (LHI pin set to "high") the combinatorial logic is switched to OR-mode to enable a channel activation via the input pins only.

[Figure 14](#) shows the complete input switch matrix.

The zener diode protects the input circuit against ESD pulses. The current sink to ground ensures that the input signal is low in case of an open input pin.

### 6.3 Input Status Monitor

The level of the input stage can be monitored via the input status monitor. The input status is indicated in the **OUT** register for the available input pin. After setting the bit **SWCR.SWR** = 1<sub>B</sub>, the readout of **OUT.INST<sub>n</sub>** shows the state of the input pins.

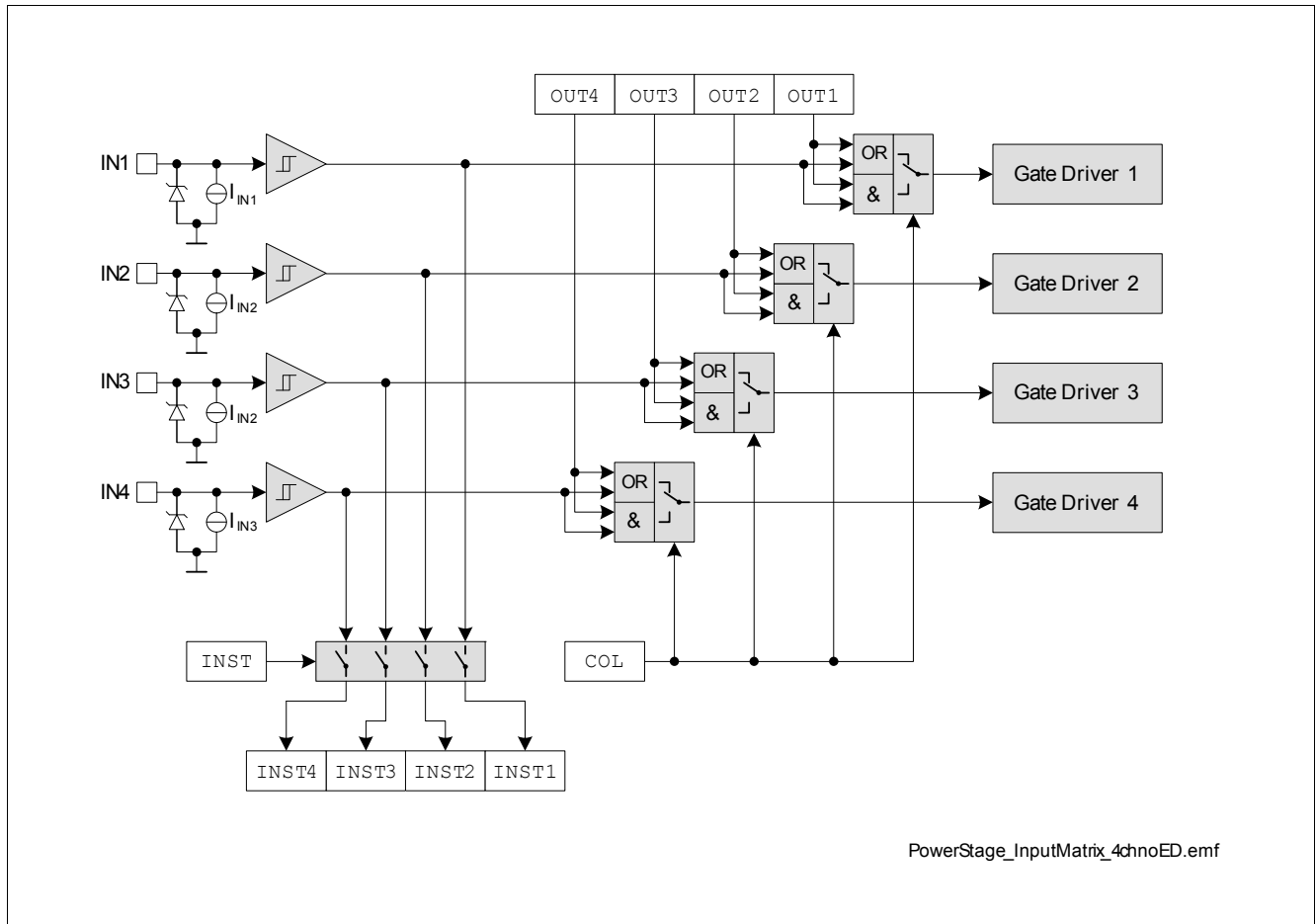

Figure 14 Input Switch Matrix

### 6.4 Power Stage Output

The power stages are built to be used in high side configuration (Figure 15).

The power DMOS switches with a dedicated slope, which is optimized in terms of electromagnetic emission (EME). Defined slew rates allow lowest EME during PWM operation at low switching losses.

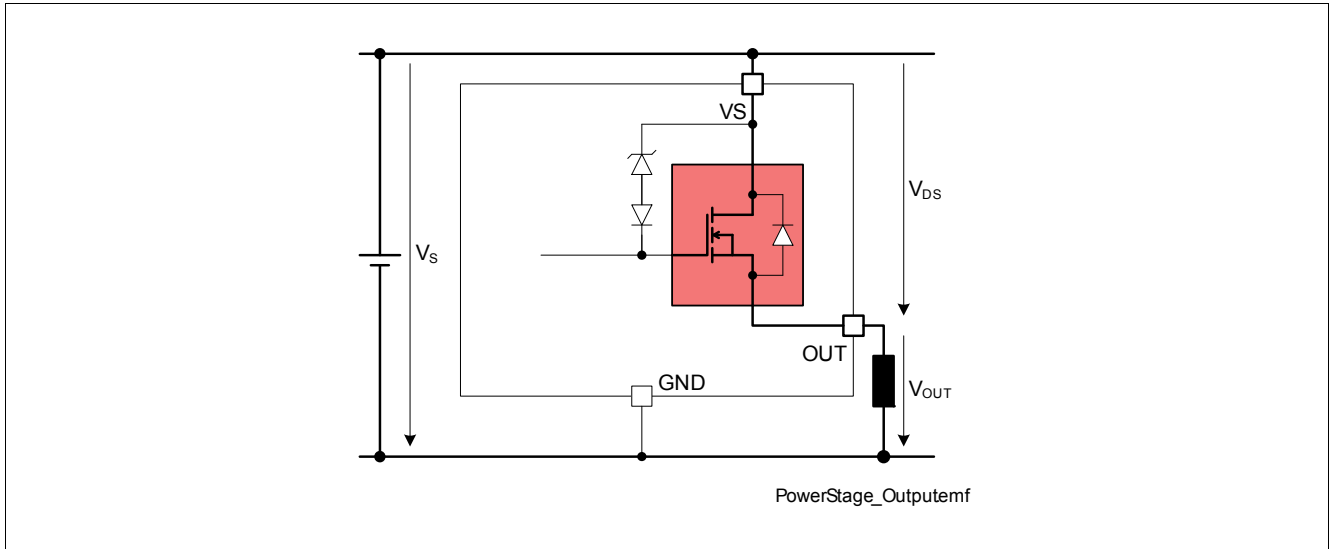

Figure 15 Power Stage Output

#### 6.4.1 Bulb and LED Mode

All four channels can be configured in bulb and LED mode via the SPI initialization registers **LGCR** when **SWCR.SWR = 0**. The default state is **LGCR.LEDn = 0**. During LED mode the following parameters are changed for an optimized functionality with LED loads: ON-state resistance  $R_{DS(ON)}$ , switching timings ( $t_{delay(ON)}$ ,  $t_{delay(OFF)}$ ,  $t_{ON}$ ,  $t_{OFF}$ ), slew rates  $dV/dt_{ON}$  and  $dV/dt_{OFF}$ , load current protections  $I_{L(LIM)}$  and current sense ratio  $k_{ILIS}$ .

#### 6.4.2 Switching Resistive Loads

When switching resistive loads the following switching times and slew rates can be considered.

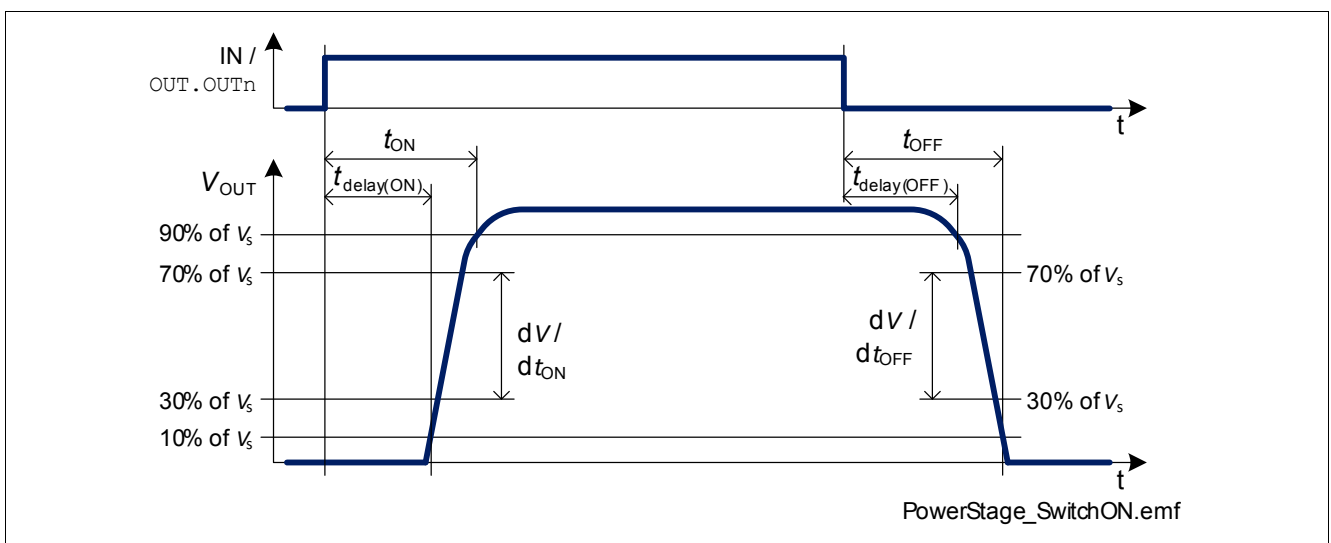

Figure 16 Switching a Load (resistive)



### 6.4.3 Switching Inductive Loads

When switching OFF inductive loads with high-side switches, the voltage  $V_{OUT}$  drops below ground potential, because the inductance intends to continue driving the current. To prevent the destruction of the device due to overvoltage, there is a voltage clamp mechanism implemented which limits that negative output voltage to a certain level ( $V_{DS(CL)}$  ([Chapter 6.5](#))). See [Figure 15](#) for details. Please refer also to [Chapter 7.4](#). The maximum allowed load inductance is limited.

### 6.4.4 Switching Channels in Parallel

In case of appearance of a short circuit with channels in parallel driving a single load, BTS54040-LBA output stages are not synchronized in the restart event. When all channels connected to the same load are in temperature limitation, the channel which has cooled down the fastest doesn't wait for the other ones to be cooled down as well to restart. Thus, it is not recommended to use the device with channels in parallel.

*Note: In case of parallel channel operation, short circuit robustness may be reduced and  $n_{RSC1}$  is not guaranteed any more.*

## 6.5 Electrical Characteristics

Unless otherwise specified:  $V_S = 7\text{ V to }18\text{ V}$ ,  $V_{DD} = 3.8\text{ V to }5.5\text{ V}$ ,  $T_j = -40\text{ °C to }+150\text{ °C}$

Typical values:  $V_S = 13.5\text{ V}$ ,  $V_{DD} = 4.3\text{ V}$ ,  $T_j = 25\text{ °C}$

Typical resistive loads connected to the outputs (unless otherwise specified):

39 mΩ channels:  $R_L = 6.8\text{ Ω}$  (33 Ω when **LGCR.LEDn** = "1")

**Table 7 Electrical Characteristics Power Stages**

Parameter	Symbol	Values			Unit	Note / Test Condition	Number
		Min.	Typ.	Max.			
<b>Output Characteristics</b>							
On-State resistance 39 mΩ ch.	$R_{DS(ON)}$	–	39	–	mΩ	1) $V_S = 9\text{ V to }18\text{ V}$ $I_L = 2.6\text{ A}$ $T_j = 25\text{ °C}$ <b>LGCR.LEDn</b> = 0	P_6.6.9
On-State resistance 39 mΩ ch.	$R_{DS(ON)}$	–	–	78	mΩ	$V_S = 9\text{ V to }18\text{ V}$ $I_L = 2.6\text{ A}$ $T_j = 150\text{ °C}$ <b>LGCR.LEDn</b> = 0	P_6.6.10
On-State resistance 39 mΩ ch. in LED mode	$R_{DS(ON)}$	–	137	–	mΩ	1) $V_S = 9\text{ V to }18\text{ V}$ $I_L = 0.6\text{ A}$ $T_j = 25\text{ °C}$ <b>LGCR.LEDn</b> = 1	P_6.6.11
On-State resistance 39 mΩ ch. in LED mode	$R_{DS(ON)}$	–	–	275	mΩ	$V_S = 9\text{ V to }18\text{ V}$ $I_L = 0.6\text{ A}$ $T_j = 150\text{ °C}$ <b>LGCR.LEDn</b> = 1	P_6.6.12
Nominal load current 39 mΩ ch. (all channels active)	$I_{L(nom)}$	–	2	–	A	1) $T_A = 85\text{ °C}$ $T_j < 150\text{ °C}$	P_6.6.17
Output clamp	$V_{DS(CL)}$	42	47	54	V	$I_L = 20\text{ mA}$	P_6.6.19
Output leakage current per channel $T_j \leq 85\text{ °C}$ 39 mΩ ch.	$I_{L(OFF)}$	–	0.02	0.5	μA	2) $V_{IN} = 0\text{ V or floating}$ <b>OUT.OUTn</b> = 0 $T_j \leq 85\text{ °C}$ Stand-by or Idle mode	P_6.6.22
Output leakage current per channel $T_j = 150\text{ °C}$ 39 mΩ ch.	$I_{L(OFF)}$	–	1.3	4.5	μA	$V_{IN} = 0\text{ V or floating}$ <b>OUT.OUTn</b> = 0 $T_j = 150\text{ °C}$ Stand-by or Idle mode	P_6.6.26
<b>Input Characteristics</b>							
L-input level	$V_{IN(L)}$	-0.3	–	1.0	V	–	P_6.6.28
H-input level	$V_{IN(H)}$	2.6	–	6.0	V	–	P_6.6.29
L-input current	$I_{IN(L)}$	3	27	75	μA	$V_{IN} = 1.0\text{ V}$	P_6.6.30
H-input current	$I_{IN(H)}$	7	30	75	μA	$V_{IN} = 2.6\text{ V}$	P_6.6.31

**Table 7 Electrical Characteristics Power Stages (cont'd)**

Parameter	Symbol	Values			Unit	Note / Test Condition	Number
		Min.	Typ.	Max.			
<b>Timings</b>							
Turn-ON delay to 10% $V_S$ (Logical propagation delay from input INn to output OUTn) 39 mΩ ch.	$t_{\text{delay(ON)}}$	10	30	70	μs	$V_S = 13.5 \text{ V}$ $\text{LGCR} . \text{LEDn} = 0$	P_6.6.36
Turn-ON delay to 10% $V_S$ (Logical propagation delay from input INn to output OUTn) 39 mΩ ch. in LED mode	$t_{\text{delay(ON)}}$	3	10	25	μs	$V_S = 13.5 \text{ V}$ $\text{LGCR} . \text{LEDn} = 1$	P_6.6.37
Turn-OFF delay to 90% $V_S$ (Logical propagation delay from input INn to output OUTn) 39 mΩ ch.	$t_{\text{delay(OFF)}}$	10	30	70	μs	$V_S = 13.5 \text{ V}$ $\text{LGCR} . \text{LEDn} = 0$	P_6.6.43
Turn-OFF delay to 90% $V_S$ (Logical propagation delay from input INn to output OUTn) 39 mΩ ch. in LED mode	$t_{\text{delay(OFF)}}$	3	10	25	μs	$V_S = 13.5 \text{ V}$ $\text{LGCR} . \text{LEDn} = 1$	P_6.6.44
Turn-ON time to 90% $V_S$ 39 mΩ ch.	$t_{\text{ON}}$	30	75	180	μs	$V_S = 13.5 \text{ V}$ $\text{LGCR} . \text{LEDn} = 0$	P_6.6.50
Turn-ON time to 90% $V_S$ 39 mΩ ch. in LED mode	$t_{\text{ON}}$	10	25	55	μs	$V_S = 13.5 \text{ V}$ $\text{LGCR} . \text{LEDn} = 1$	P_6.6.51
Turn-OFF time to 10% $V_S$ 39 mΩ ch.	$t_{\text{OFF}}$	30	75	180	μs	$V_S = 13.5 \text{ V}$ $\text{LGCR} . \text{LEDn} = 0$	P_6.6.57
Turn-OFF time to 10% $V_S$ 39 mΩ ch. in LED mode	$t_{\text{OFF}}$	10	25	55	μs	$V_S = 13.5 \text{ V}$ $\text{LGCR} . \text{LEDn} = 1$	P_6.6.58
Turn-ON/OFF matching 39 mΩ ch.	$t_{\text{ON}} - t_{\text{OFF}}$	-30	0	50	μs	$V_S = 13.5 \text{ V}$ $\text{LGCR} . \text{LEDn} = 0$	P_6.6.68
Turn-ON/OFF matching 39 mΩ ch. in LED mode	$t_{\text{ON}} - t_{\text{OFF}}$	-20	0	20	μs	$V_S = 13.5 \text{ V}$ $\text{LGCR} . \text{LEDn} = 1$	P_6.6.69
Turn-ON slew rate 30% to 70% $V_S$ 39 mΩ ch.	$dV/dt_{\text{ON}}$	0.1	0.25	0.5	V/μs	$V_S = 13.5 \text{ V}$ $\text{LGCR} . \text{LEDn} = 0$	P_6.6.75
Turn-ON slew rate 30% to 70% $V_S$ 39 mΩ ch. in LED mode	$dV/dt_{\text{ON}}$	0.35	0.88	1.75	V/μs	$V_S = 13.5 \text{ V}$ $\text{LGCR} . \text{LEDn} = 1$	P_6.6.76

**Table 7 Electrical Characteristics Power Stages (cont'd)**

Parameter	Symbol	Values			Unit	Note / Test Condition	Number
		Min.	Typ.	Max.			
Turn-OFF slew rate 70% to 30% $V_S$ 39 m $\Omega$ ch.	$-dV/dt_{OFF}$	0.1	0.25	0.5	V/ $\mu$ s	$V_S = 13.5$ V $LGCR.LEDn = 0$	P_6.6.82
Turn-OFF slew rate 70% to 30% $V_S$ 39 m $\Omega$ ch. in LED mode	$-dV/dt_{OFF}$	0.35	0.88	1.75	V/ $\mu$ s	$V_S = 13.5$ V $LGCR.LEDn = 1$	P_6.6.83
<b>Output Voltage Drop</b>							
Output voltage drop limitation at small load currents 39 m $\Omega$ ch. in LED mode	$V_{DS(NL)}$	-	10	25	mV	$I_L = 50$ mA $LGCR.GBRn = 1$	P_6.6.94

1) Not subject to production test, specified by design.

 2) Tested at  $T_j = -40$  °C

## 7 Protection Functions

The device provides embedded protective functions, which are designed to prevent IC destruction under fault conditions described in this data sheet. Fault conditions are considered as “outside” normal operating range. Protective functions are neither designed for continuous nor for repetitive operation.

### 7.1 Over Load Protection

The load current  $I_L$  is limited by the device itself in case of over load or short circuit to ground. All channels have 2 steps of current limitation which are selected automatically depending on the voltage  $V_{DS}$  across the power DMOS as show in **Figure 17**. Please note that  $V_{OUT} = V_S - V_{DS}$ . The current limitation threshold when  $V_{DS} = 5\text{ V}$  is taken as reference.

Current limitation to the value  $I_{L(LIM)}$  is realized by increasing the resistance of the output channel, which leads to fast DMOS temperature rise.

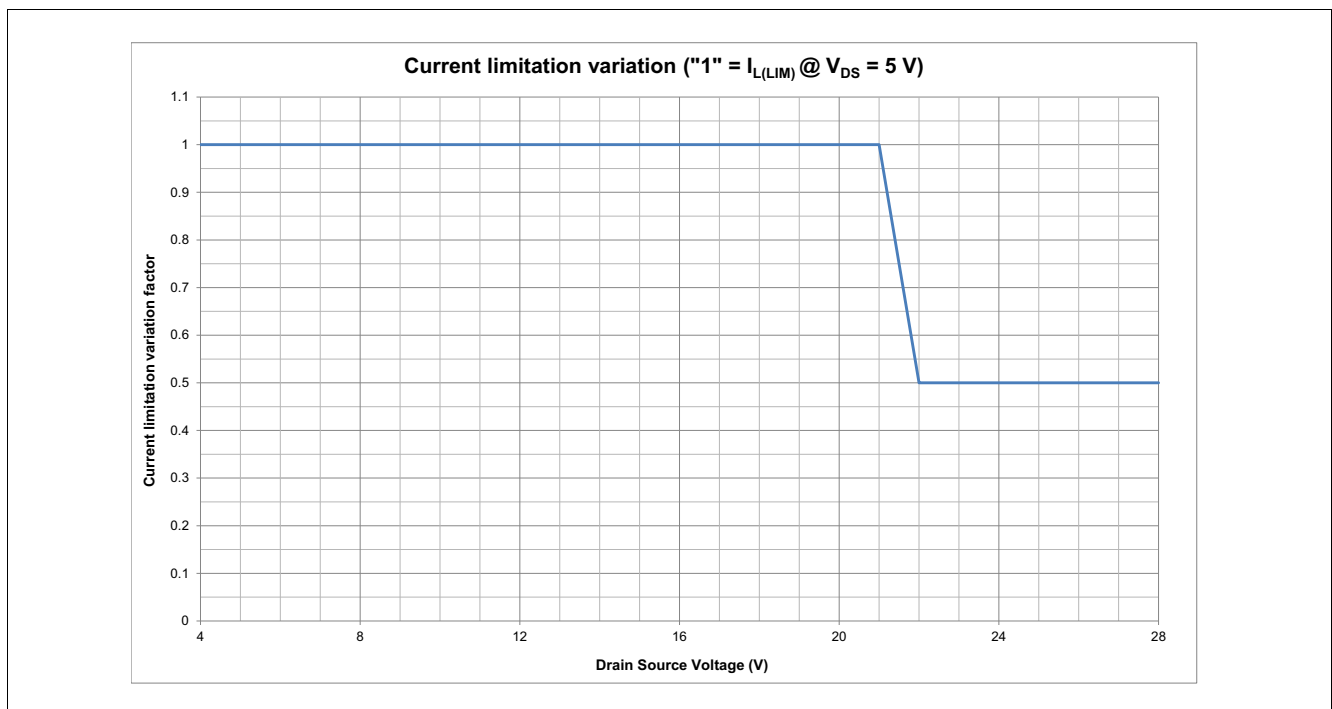

**Figure 17** Typical Current Limitation variation according to  $V_{DS}$  voltage

### 7.2 Over Temperature Protection

Each channel incorporates both an absolute ( $T_{j(SC)}$ ) and a dynamic ( $\Delta T_{j(SW)}$ ) temperature sensor. An increase of junction temperature  $T_j$  above one of the two thresholds ( $T_{j(SC)}$  or  $\Delta T_{j(SW)}$ ) switches OFF an overheated channel to prevent destruction. Any protective switch OFF deactivates the output until the temperature has reached an acceptable value.

Each protective switch OFF event increments the error counter by one. The number of automatic reactivations is limited by  $n_{retry}$ . If this number of retries is reached the channel turns OFF and latches OFF.

The error information related to the given channel is available on the Standard Diagnosis and Errors Diagnosis. Executing **HWCR.CTC** =  $1_B$  will clear all thermal counters and errors on all channels. If the channel is active (either **OUT.OUTn** =  $1_B$  or **INn** = “high” and **DCR.MUX**  $\neq 111_B$ ) it is turned on immediately after the SPI command. In addition the execution of the reset command (**HWCR.RST** =  $1_B$ ) will clear the thermal counters.

---

**Protection Functions**

For the condition  $n < n_{\text{retry}}$  the counter of automatic reactivations is reset by every channel activation if **HWCR . RCR** bit is set to 1. In **Figure 20** the different behavior of retry counters according to **HWCR . RCR** bit value can be seen.

In Limp Home Mode, the thermal counters of the protection functions are only operative if  $V_{\text{DD}}$  is provided in the specified range. Otherwise the counters are not active and all channels are in „unlimited restart“ mode.

In case of the short circuit to ground, current sense ratio ( $k_{\text{ILIS}}$ ) is deactivated as soon as  $V_{\text{DS}} > V_{\text{DS(SB)}}$  (Switch bypass monitor threshold). Usually a short circuit to ground condition tends to set  $V_{\text{DS}} = V_{\text{S}}$  therefore in most of the cases no current sensing diagnostic is possible in short circuit.

The error information related to the given channel are available also on Warnings Diagnosis (**ERRn** bits).

Refer to **Figure 18** and **Figure 19** for details.

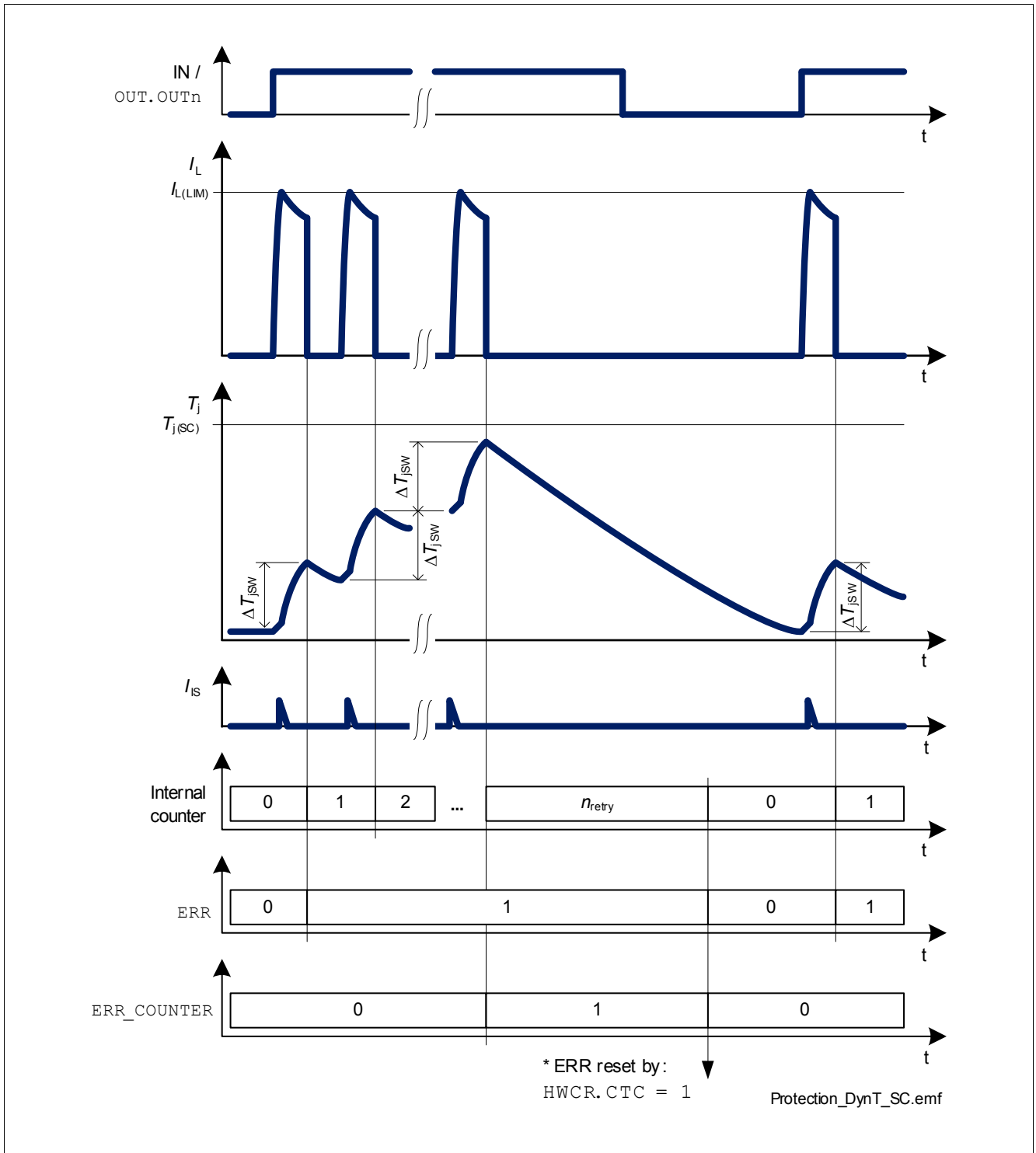

Figure 18 Dynamic Temperature Sensor Operations - Short Circuit

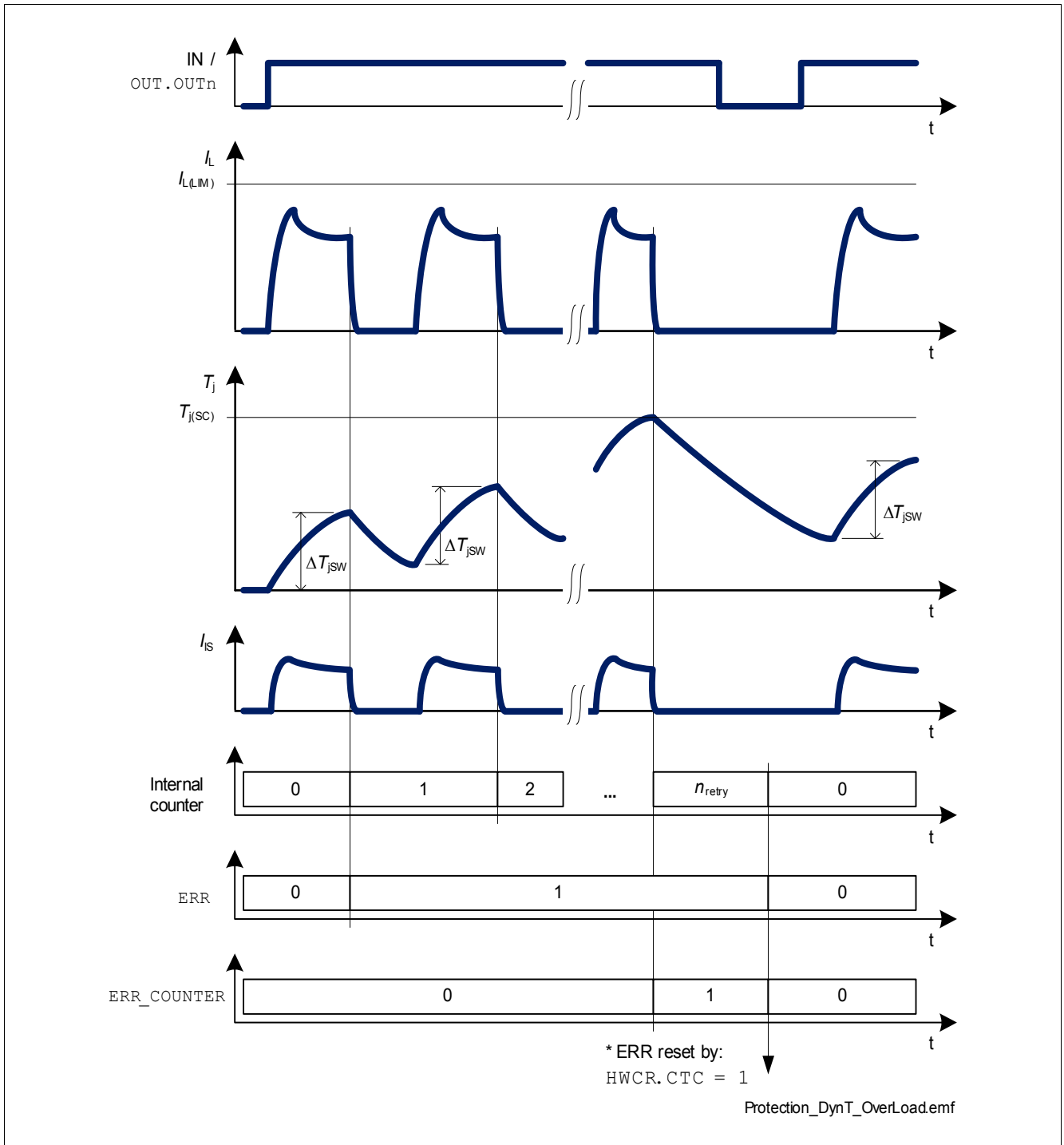

Figure 19 Dynamic and Absolute Temperature Sensor Operations - Overload Condition



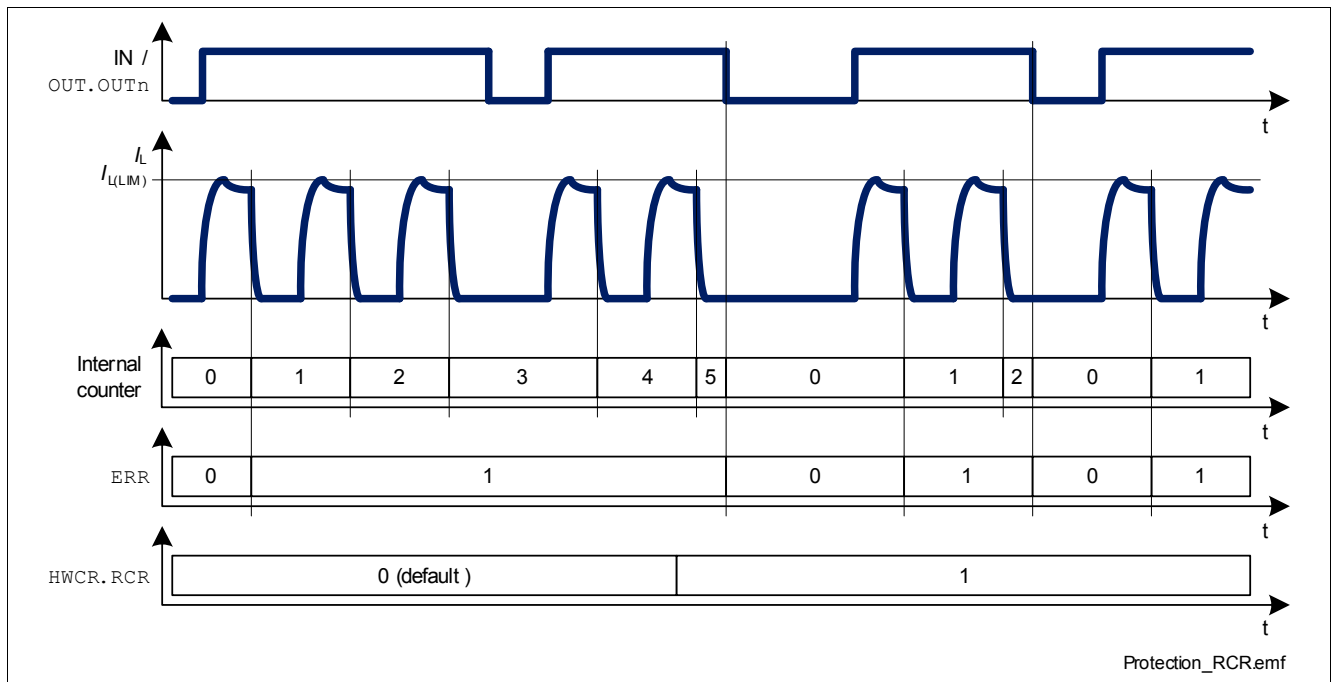

Figure 20 Different counter reset according to HWCR. RCR bit value

### 7.3 Reverse Polarity Protection

In reverse polarity condition, power dissipation is caused by the intrinsic body diode of each DMOS channel as well as each ESD diode of the logic pins. The reverse current through the channels has to be limited by the connected loads. The current through ground pin GND, sense pin IS, logic power supply pin VDD, SPI pins, input pins and Limp Home Input pin has to be limited as well (please refer to the maximum ratings listed on [Chapter 4.1](#)).

*Note: No protection mechanism like temperature protection or current limitation is active during reverse polarity.*

### 7.4 Over Voltage Protection

In the case of supply voltages between  $V_{S(SC)max}$  and  $V_{S(AZ)}$  the output transistors are still operational and follow the input or the **OUT** register. Parameters are not warranted and lifetime is reduced compared to nominal voltage supply.

In addition to the output clamp for inductive loads as described in [Chapter 6.4.3](#), there is a clamp mechanism available for over voltage protection for the logic and all channels.

### 7.5 Loss of Ground

In case of complete loss of the device ground connection, but loads connected to ground, the BTS54040-LBA securely changes to or stays in OFF-state. Please refer to [Chapter 10](#) where an application setup is described.

### 7.6 Loss of $V_S$

In case of loss of  $V_S$  connection in ON-state, all inductances of the loads have to be demagnetized through the ground connection or through an additional path from  $V_S$  to ground. For example, a suppressor diode is recommended between  $V_S$  and GND.

## 7.7 Electrical Characteristics

Unless otherwise specified:  $V_S = 7\text{ V to }18\text{ V}$ ,  $V_{DD} = 3.8\text{ V to }5.5\text{ V}$ ,  $T_j = -40\text{ °C to }+150\text{ °C}$   
 typical values:  $V_S = 13.5\text{ V}$ ,  $V_{DD} = 4.3\text{ V}$ ,  $T_j = 25\text{ °C}$

Typical resistive loads connected to the outputs (unless otherwise specified):

39 mΩ channels:  $R_L = 6.8\text{ Ω}$  (33 Ω when **LGCR.LEDn** = "1")

**Table 8 Electrical Characteristics Protection Functions**

Parameter	Symbol	Values			Unit	Note / Test Condition	Number
		Min.	Typ.	Max.			
<b>Over Load Protection</b>							
Load current limitation 39 mΩ ch.	$I_{L(LIM)}$	25	32	44	A	1) $V_{DS} = 5\text{ V}$ <b>LGCR.LEDn</b> = 0	P_7.7.9
Load current limitation 39 mΩ ch.	$I_{L(LIM)}$	–	16	–	A	1) $V_{DS} = 26\text{ V}$ <b>LGCR.LEDn</b> = 0	P_7.7.10
Load current limitation 39 mΩ ch. in LED mode	$I_{L(LIM)}$	6.5	9	16	A	$V_{DS} = 5\text{ V}$ $T_j = -40\text{ °C}$ <b>LGCR.LEDn</b> = 1	P_7.7.11
Load current limitation 39 mΩ ch. in LED mode	$I_{L(LIM)}$	–	4.5	–	A	1) $V_{DS} = 26\text{ V}$ <b>LGCR.LEDn</b> = 1	P_7.7.12
<b>Over Temperature Protection</b>							
Thermal shut down temperature	$T_{j(SC)}$	150	170	200	°C	1)	P_7.7.14
Thermal hysteresis of thermal shutdown	$\Delta T_{j(SC)}$	–	20	–	K	1)	P_7.7.15
Dynamic temperature increase limitation while switching	$\Delta T_{j(SW)}$	–	80	–	K	1)	P_7.7.16
Number of automatic retries at dynamic temperature sensor or over temperature shut down	$n_{retry}$	–	8	9		1)	P_7.7.17
<b>Reverse Polarity</b>							
Drain source diode voltage during reverse polarity 39 mΩ ch.	$V_{DS(REV)}$	400	650	800	mV	$I_L = I_{L(nom)} =$ P_6.6.17 $T_j = 150\text{ °C}$	P_7.7.20
<b>Over Voltage</b>							
Overvoltage protection	$V_{S(AZ)}$	42	47	54	V	$I_S = 4\text{ mA}$	P_7.7.22

1) Not subject to production test, specified by design.

## 8 Diagnosis

For diagnosis purpose, the BTS54040-LBA provides a current sense signal at pin IS and a diagnosis word via SPI. There is a current sense multiplexer implemented that is controlled via SPI. The sense signal can also be disabled by SPI command. A switch bypass monitor allows to detect a short circuit between the output pin and the battery voltage.

Please refer to [Figure 21](#) for details.

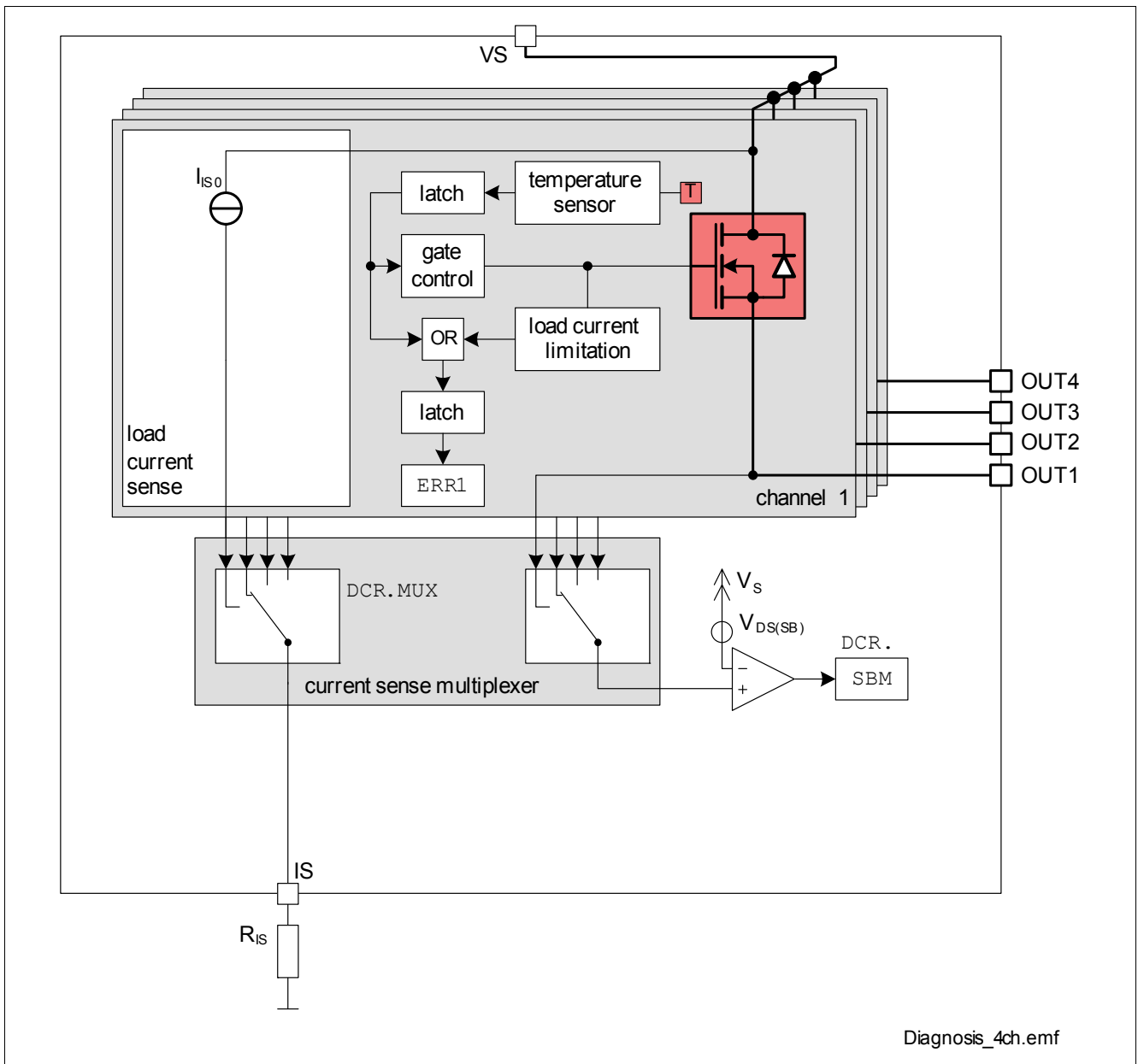

**Figure 21 Block Diagram: Diagnosis**

For diagnosis feedback at different operation modes, please see [Table 9](#).

**Table 9 Operation Modes** <sup>1)</sup>

Operation Mode	Input Level <b>OUT . OUTn</b>	Output Level $V_{OUT}$	Current Sense $I_{IS}$	Error Flag <b>ERR_COUNTERn</b> <sup>2)</sup>	Warning Flag <b>ERRn</b> <sup>3)</sup>	<b>DCR . SBM</b> bit
Normal Operation ( <b>Channel OFF</b> )	L / 0 (OFF-state)	GND	Z	0	0	1
Short Circuit to GND		GND	Z	0	0	1
Thermal shut down		Z	Z	0 <sup>2)</sup>	0 <sup>2)</sup>	X
Short Circuit to $V_S$		$V_S$	Z	0	0	0
Open Load		Z	Z	0	0	X
Normal Operation ( <b>Channel ON</b> )	H / 1 (ON-state)	$\sim V_S$	$I_L / k_{ILIS}$	0	0	0
Current Limitation		$< V_S$	Z	0	0	X
Dynamic or Absolute Thermal Limitation → Channel switched OFF		Z	Z	0	1	X
Dynamic or Absolute Thermal Limitation $n_{retry}$ reached → Channel latched OFF		Z	Z	1 <sup>2)</sup>	1	X
Short Circuit to GND		$\sim$ GND	Z	0	0	1
Short Circuit to $V_S$		$V_S$	$< I_L / k_{ILIS}$	0	0	0
Open Load		$V_S$	Z	0	0	0

1) L = "low" level, H = "high" level, Z = high impedance, potential depends on leakage currents and external circuit.  
X = undefined.

2) The over temperature flag is set latched and can be cleared by setting **HWCR . CTC** = 1<sub>B</sub>.

3) The warning flags are latched until they are reset (see **HWCR . RCR** description).

## 8.1 Diagnosis Word at SPI

Diagnostic information about the status of each channel is provided through SPI. In the Standard Diagnosis the **ERR\_MUX** bit reports if there is a channel which had already enough restarts to reach the maximum allowed number of retries  $n_{retry}$  (P\_7.7.17). If 2 or more channels are latched OFF due to that, **ERR\_MUX** bits aren't enough to identify which channels are OFF. In such cases, it is possible to get an overview channel by channel using **ERR\_COUNTERn** bits in Errors Diagnosis (see [Chapter 9.6.2](#))

It is possible to check if one or more channels had some retries during switching ON, although the limit of  $n_{retry}$  was not reached. An overview channel by channel of thermal counter status is available using **ERRn** bits in Warnings Diagnosis (see [Chapter 9.6.3](#)).

For both **ERR\_COUNTERn** and **ERRn** the information on channel n is given at bit n-1 (e.g. bit 0 indicates status of channel 1).

## 8.2 Load Current Sense Diagnosis

There is a current sense signal available at pin IS which provides a current proportional to the load current of one selected channel. The selection is done by a multiplexer which is configured via SPI.

### 8.2.1 Current Sense Signal

The current sense signal (ratio  $k_{ILIS} = I_L / I_S$ ) is provided during ON-state as long as no failure mode occurs. For dedicated channels the ratio  $k_{ILIS}$  can be adjusted to the load type (LED or bulb) via SPI register **LGCR**. The accuracy of the ratio  $k_{ILIS}$  depends on the load current and temperature. Usually a resistor  $R_{IS}$  is connected to the current sense pin. It is recommended to use resistors  $1.5 \text{ k}\Omega < R_{IS} < 5 \text{ k}\Omega$ . A typical value is  $2.7 \text{ k}\Omega$ .

The current sense signal of a channel is not active when the channel is OFF or when the protection functions (current limitation, over temperature or dynamic temperature sensors) are active. If the maximum number of automatic reactivations  $n_{\text{retry}}$  is reached ( $n = n_{\text{retry}}$ ), the current sense signal of the affected channel is deactivated until the reset of the counters by setting **HWCR.CTC** bit to 1.

Details about timings between the current sense signal  $I_S$  and the output voltage  $V_{\text{OUT}}$  and the load current  $I_L$  can be found in **Figure 22**.

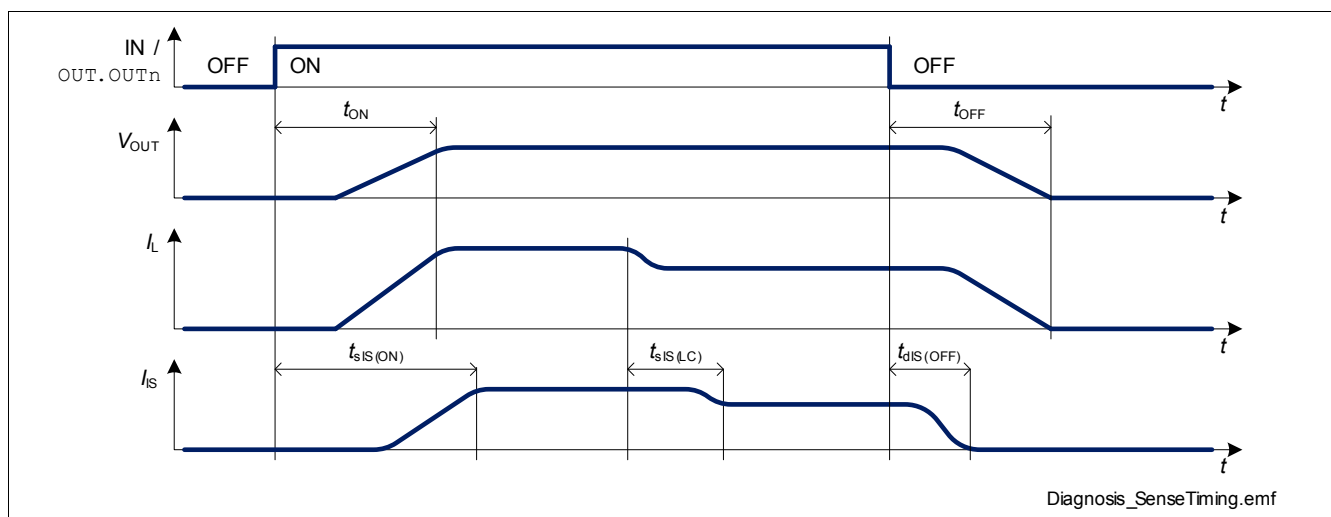

**Figure 22** Current Sense Signal Timings

### 8.2.2 Current Sense Multiplexer

There is a current sense multiplexer implemented in the BTS54040-LBA that routes the sense current of the selected channel to the diagnosis pin IS. The channel is selected via SPI register **DCR.MUX**. The sense current can also be disabled by SPI register **DCR.MUX**. For details on timing of the current sense multiplexer, please refer to **Figure 23**.

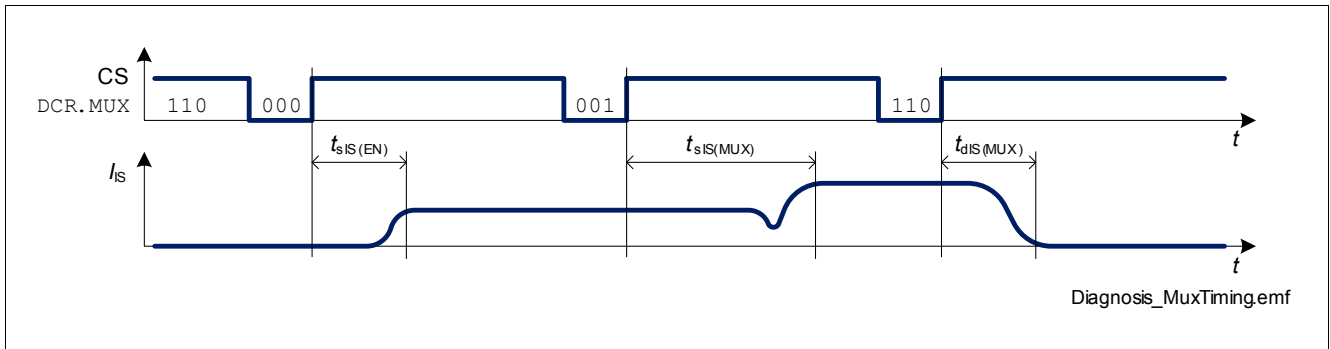

Figure 23 Current Sense Multiplexer Timings

### 8.2.3 Open Load at ON Diagnosis

If a channel is ON in Open Load condition, a small current can still flow, for example because of humidity. The parameter  $I_{L(OL)}$  gives the threshold of recognition for such leakage current. If the voltage measured at the sense resistor  $R_{SENSE}$  corresponds to a current  $I_{IS(OL)}$  ( $4 \mu A$ ), then the current flowing at the output in ON state is within the limits given by  $I_{L(OL)}$ . **Figure 24** shows the sense current behavior once a channel in Open Load at ON condition is selected with the sense current multiplexer. The red curve show a typical product curve. The blue line shows the ideal  $k_{ILIS}$  ratio.

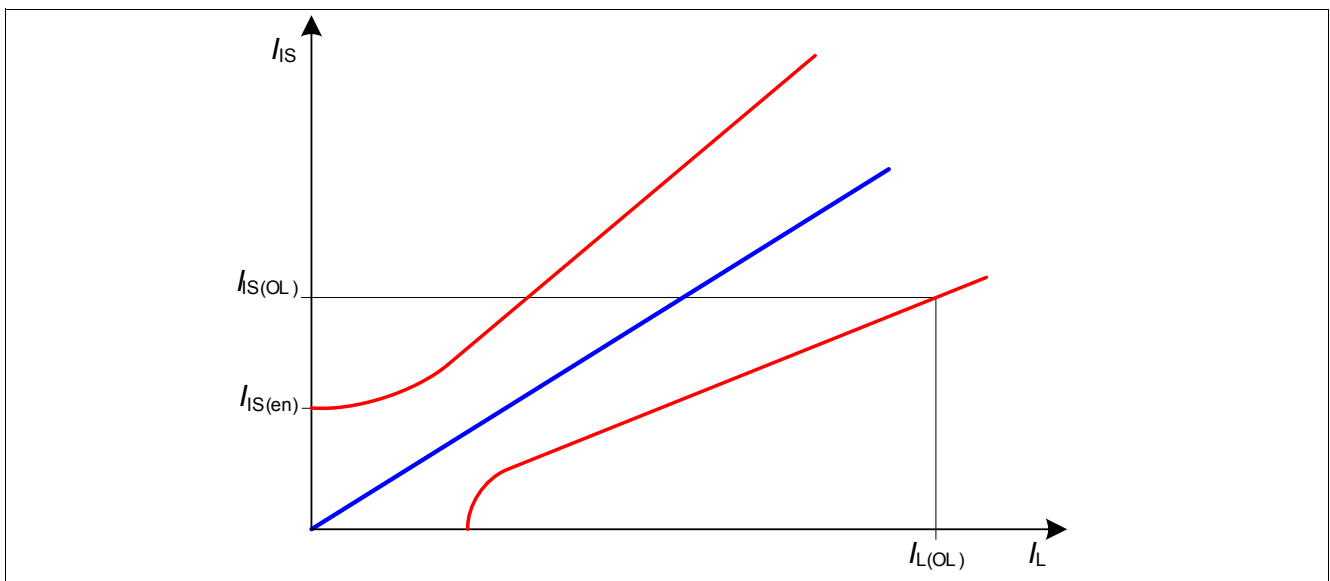

Figure 24 Current Sense Ratio in Open Load at ON condition

### 8.3 Switch Bypass Monitor Diagnosis

To detect short circuit to  $V_S$ , there is a switch bypass monitor implemented. In case of short circuit between the output pin OUT and VS in ON-state, the current flows through the power transistor as well as through the short circuit (bypass) with undefined share between the two. As a result, the current sense signal shows lower values than expected by the load current. In OFF-state, the output voltage remains close to  $V_S$  potential which leads to a small  $V_{DS}$ .

The switch bypass monitor compares the threshold  $V_{DS(SB)}$  with the voltage  $V_{DS}$  across the power transistor of that channel which is selected by the current sense multiplexer (**DCR.MUX**). The result of the comparison can be read in SPI register **DCR.SBM**.

## 8.4 Gate Back Regulation

To increase the current sense accuracy, the Gate Back Regulation (GBR) function is implemented. This function monitors the  $V_{DS}$  voltage at the output and if the value is equal to or lower than  $V_{DS(NL)}$  the output DMOS gate is partially discharged. This increases output DMOS resistance so that  $V_{DS} = V_{DS(NL)}$  even for very small output currents. The  $V_{DS}$  increase allows the current sensing circuitry to work with better accuracy, providing tighter  $k_{LIS}$  values for output currents in the low range.

This function is active by default (**LGCR.GBRn** bits set to “1” after a reset). According to output current, GBR function can be left active or disabled. Even if left active, Gate Back Regulation circuitry may not be working because the measured  $V_{DS}$  is bigger than  $V_{DS(NL)}$  (depending on output current, junction temperature, output DMOS resistance).

Due to production and temperature variations, GBR circuitry can affect  $k_{LIS}$  performance in negative way for some output current values. For this reason, **Table 10** indicates for which output currents it is necessary to deactivate GBR (setting the corresponding **LGCR.GBRn** bit to “0”) to reach the desired current accuracy. If no indication is given, then the GBR function is assumed to be enabled (**LGCR.GBRn** bit set to “1”). It is recommended to keep GBR circuitry enabled for Open Load at ON diagnosis.

The circuitry that controls GBR function can be deactivated with the following SPI command sequence:

- **SWCR.SWR** = 1 (SPI command: 11001100<sub>B</sub>)
- **LGCR.GBRn** = 0 (SPI command: 1101aaaa<sub>B</sub> where “aaaa”<sub>B</sub> is the new value for **LGCR.GBRn** bits)
- (optional but recommended: **SWCR.SWR** = 0 (SPI command: 11000100<sub>B</sub>))

Refer to **Chapter 9.7** for more details.

## 8.5 Electrical Characteristics

Unless otherwise specified:  $V_S = 7\text{ V to }18\text{ V}$ ,  $V_{DD} = 3.8\text{ V to }5.5\text{ V}$ ,  $T_j = -40\text{ °C to }+150\text{ °C}$

Typical values:  $V_S = 13.5\text{ V}$ ,  $V_{DD} = 4.3\text{ V}$ ,  $T_j = 25\text{ °C}$

Typical resistive loads connected to the outputs (unless otherwise specified):

39 mΩ channels:  $R_L = 6.8\text{ Ω}$  (33 Ω when **LGCR.LEDn** = "1")

Measurement setup used for  $k_{ILIS}$  (unless otherwise specified):

When  $I_L \leq 1.3\text{ A}$  all channels are ON at the same time with equal  $I_L$

When  $I_L \geq 2.0\text{ A}$  only the measured channel is ON, all other channels have  $I_L = 0$

**Table 10 Electrical Characteristics Diagnosis  $k_{ILIS}$  39 mΩ ch.**

Parameter	Symbol	Values			Unit	Note / Test Condition	Number
		Min.	Typ.	Max.			

### Current Sense Ratio Signal in the Nominal Area, Stable Load Current Condition 39 mΩ ch.

Current sense ratio $I_{L03} = 300\text{ mA}$	$k_{ILIS03}$	-36 %	2000	+36 %		–	P_8.5.49
Current sense ratio $I_{L05} = 600\text{ mA}$	$k_{ILIS05}$	-29 %	2000	+29 %		–	P_8.5.51
Current sense ratio $I_{L07} = 1.3\text{ A}$	$k_{ILIS07}$	-15 %	2000	+15 %		–	P_8.5.53
Current sense ratio $I_{L09} = 2.6\text{ A}$	$k_{ILIS09}$	-12 %	2000	+12 %		–	P_8.5.55
Current sense ratio $I_{L10} = 4\text{ A}$	$k_{ILIS10}$	-11 %	2000	+11 %		–	P_8.5.56

### Current Sense Ratio Signal in the Nominal Area, Stable Load Current Condition 39 mΩ ch. in LED mode

Current sense ratio $I_{L00} = 20\text{ mA}$	$k_{ILIS00}$	-52 %	620	+52 %		–	P_8.5.57
Current sense ratio $I_{L02} = 150\text{ mA}$	$k_{ILIS02}$	-30 %	570	+30 %		–	P_8.5.59
Current sense ratio $I_{L03} = 300\text{ mA}$	$k_{ILIS03}$	-15 %	570	+15 %		–	P_8.5.60
Current sense ratio $I_{L05} = 600\text{ mA}$	$k_{ILIS05}$	-11 %	570	+11 %		–	P_8.5.62
Current sense ratio $I_{L06} = 1\text{ A}$	$k_{ILIS06}$	-10 %	570	+10 %		–	P_8.5.63



Table 11 Electrical Characteristics Diagnosis

Parameter	Symbol	Values			Unit	Note / Test Condition	Number
		Min.	Typ.	Max.			
Sense pin maximum voltage	$V_{IS(AZ)}$	42	47	54	V	$I_{IS} = 5 \text{ mA}$	P_8.5.75
<b>Current Sense Drift Over Current and Temperature per Device</b>							
Current sense drift over current and temperature per device 39 mΩ ch.	$\Delta k_{ILIS(T)}$	-8	–	8	%	1) $k_{ILIS09}$ versus $k_{ILIS07}$ LGCR.LEDn = 0	P_8.5.80
Current sense drift over current and temperature per device 39 mΩ ch. in LED mode	$\Delta k_{ILIS(T)}$	-9.5	–	9.5	%	1) $k_{ILIS05}$ versus $k_{ILIS03}$ LGCR.LEDn = 1	P_8.5.81

Table 11 Electrical Characteristics Diagnosis (cont'd)

Parameter	Symbol	Values			Unit	Note / Test Condition	Number
		Min.	Typ.	Max.			
<b>Current Sense Drift of Unaffected Channel during Inverse Current of other Channels</b>							
<b>One channel with <math>I_{L(IC)} = -I_{Ln}</math>, all other channels with <math>I_{Ln}</math></b>							
<b>DCR.MUX <math>\neq</math> &lt;111, 110&gt; and set to sense any of the channels not in Inverse current condition</b>							
Current sense drift of unaffected channels during inverse current of one channel	$\Delta k_{ILIS(IC)}$	-20	–	20	%	1) $I_{L1} = 2.6 \text{ A}$ $I_{L2} = 2.6 \text{ A}$ $I_{L3} = 2.6 \text{ A}$ $I_{L4} = 2.6 \text{ A}$	P_8.5.84
<b>Sense Pin - Currents</b>							
Maximum steady state current sense output current 39 m $\Omega$ ch.	$I_{IS(MAX)}$	3.8	–	15	mA	$V_{IS} = 0 \text{ V}$ $V_S \geq 8 \text{ V}$	P_8.5.88
Current sense leakage / offset current	$I_{IS(en)}$	–	–	1	$\mu\text{A}$	1) $T_j \leq 85 \text{ }^\circ\text{C}$ $I_L = 0 \text{ mA}$ DCR.MUX $\neq$ <111,110> <sub>B</sub>	P_8.5.118
Current sense leakage / offset current	$I_{IS(en)}$	–	–	3.2	$\mu\text{A}$	$T_j = 150 \text{ }^\circ\text{C}$ $I_L = 0 \text{ mA}$ DCR.MUX $\neq$ <111,110> <sub>B</sub>	P_8.5.90
Open load detection threshold in ON state 39 m $\Omega$ ch.	$I_{L(OL)}$	–	–	21.5	mA	$I_{IS(OL)} = 4 \text{ } \mu\text{A}$ LGCR.LEDn = 0	P_8.5.95
Open load detection threshold in ON state 39 m $\Omega$ ch. in LED mode	$I_{L(OL)}$	–	–	7.5	mA	$I_{IS(OL)} = 4 \text{ } \mu\text{A}$ LGCR.LEDn = 1	P_8.5.96
Current sense leakage, while diagnosis disabled	$I_{IS(dis)}$	–	0.01	1	$\mu\text{A}$	$I_{L2} = 2.6 \text{ A}$ DCR.MUX = 110 <sub>B</sub>	P_8.5.98
<b>Sense Pin - Timings</b>							
Current sense settling time after channel activation 39 m $\Omega$ ch.	$t_{sIS(ON)}$	–	–	250	$\mu\text{s}$	$V_S = 13.5 \text{ V}$ $R_{IS} = 2.7 \text{ k}\Omega$ LGCR.LEDn = 0	P_8.5.103
Current sense settling time after channel activation 39 m $\Omega$ ch. in LED mode	$t_{sIS(ON)}$	–	–	100	$\mu\text{s}$	$V_S = 13.5 \text{ V}$ $R_{IS} = 2.7 \text{ k}\Omega$ LGCR.LEDn = 1	P_8.5.104
Current sense desettling time after channel deactivation	$t_{dis(OFF)}$	–	–	25	$\mu\text{s}$	$V_S = 13.5 \text{ V}$ $R_{IS} = 2.7 \text{ k}\Omega$	P_8.5.106

**Table 11 Electrical Characteristics Diagnosis (cont'd)**

Parameter	Symbol	Values			Unit	Note / Test Condition	Number
		Min.	Typ.	Max.			
Current sense settling time after change of load current 39 mΩ ch.	$t_{sIS(LC)}$	–	–	25	μs	1) $I_L = 2.6 \text{ A to } 1.3 \text{ A}$ $V_S = 13.5 \text{ V}$ $R_{IS} = 2.7 \text{ k}\Omega$ <b>LGCR.LEDn</b> = 0	P_8.5.111
Current sense settling time after change of load current 39 mΩ ch. in LED mode	$t_{sIS(LC)}$	–	–	25	μs	1) $I_L = 1.0 \text{ A to } 0.6 \text{ A}$ $V_S = 13.5 \text{ V}$ $R_{IS} = 2.7 \text{ k}\Omega$ <b>LGCR.LEDn</b> = 1	P_8.5.112
Current sense settling time after current sense activation	$t_{sIS(EN)}$	–	–	25	μs	$R_{IS} = 2.7 \text{ k}\Omega$ $I_{L2} = 2.6 \text{ A}$ <b>DCR.MUX</b> : 110 <sub>B</sub> → 001 <sub>B</sub>	P_8.5.114
Current sense settling time after multiplexer channel change	$t_{sIS(MUX)}$	–	–	25	μs	$R_{IS} = 2.7 \text{ k}\Omega$ $I_{L2} = 2.6 \text{ A}$ $I_{L3} = 4 \text{ A}$ <b>DCR.MUX</b> : 001 <sub>B</sub> → 010 <sub>B</sub>	P_8.5.115
Current sense deactivation time	$t_{dIS(MUX)}$	–	–	25	μs	1) $R_{IS} = 2.7 \text{ k}\Omega$ <b>DCR.MUX</b> : 010 <sub>B</sub> → 110 <sub>B</sub>	P_8.5.116
<b>Switch Bypass Monitor</b>							
Switch bypass monitor threshold	$V_{DS(SB)}$	1.5	3.3	4.5	V	OFF state	P_8.5.117

1) Not subject to production test, specified by design.

## 9 Serial Peripheral Interface (SPI)

The serial peripheral interface (SPI) is a full duplex synchronous serial slave interface, which uses four lines: SO, SI, SCLK and CS. Data is transferred by the lines SI and SO at the rate given by SCLK. The falling edge of CS indicates the beginning of an access. Data is sampled in on line SI at the falling edge of SCLK and shifted out on line SO at the rising edge of SCLK. Each access must be terminated by a rising edge of CS. A modulo 8 counter ensures that data is taken only when a multiple of 8 bit has been transferred. The interface provides daisy chain capability with 8-bit SPI devices.

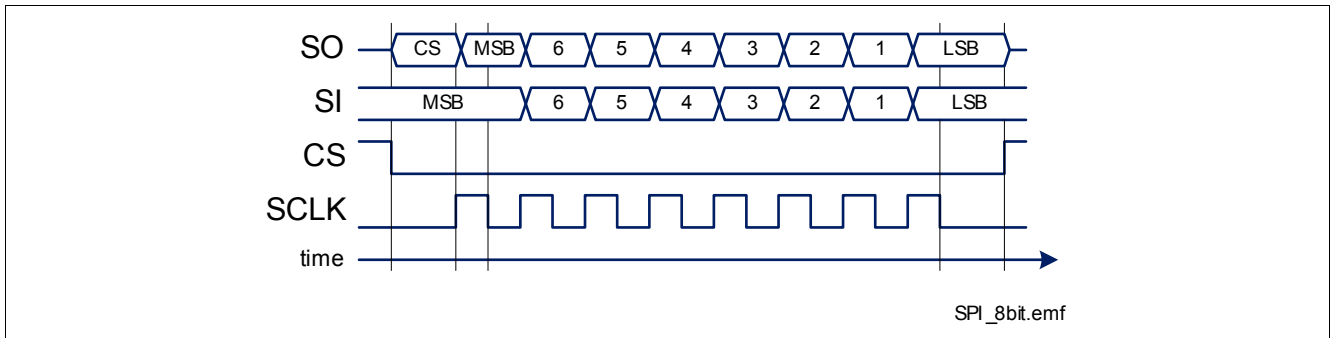

Figure 25 Serial Peripheral Interface

### 9.1 SPI Signal Description

#### CS - Chip Select

The system micro controller selects the BTS54040-LBA by means of the CS pin. Whenever the pin is in “low” state, data transfer can take place. When CS is in “high” state, any signals at the SCLK and SI pins are ignored and SO is forced into a high impedance state.

#### CS “high” to “low” Transition

- The requested information is transferred into the shift register.
- SO changes from high impedance state to “high” or “low” state depending on the signal level at pin SI.

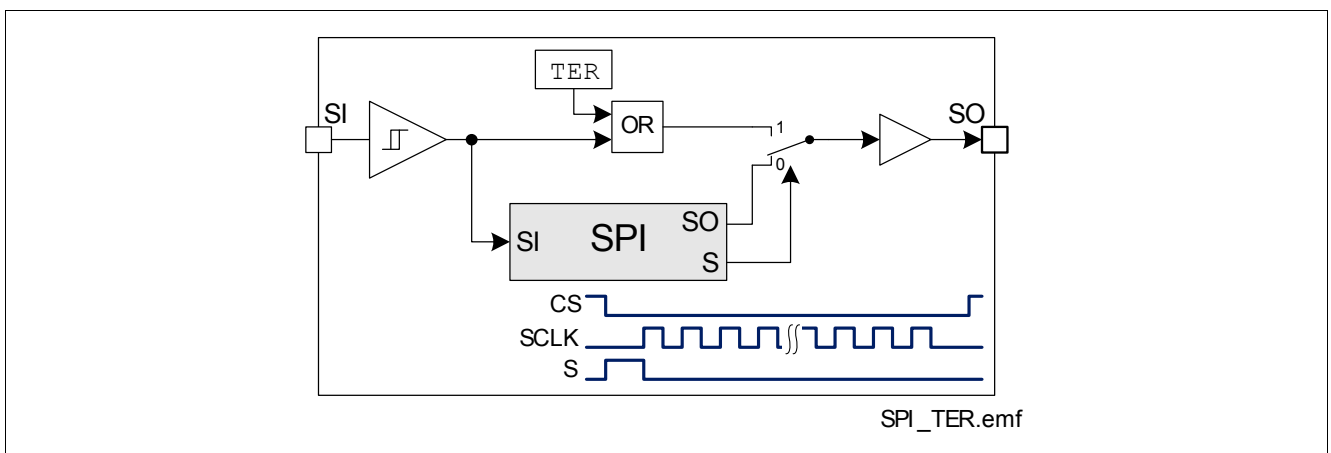

Figure 26 Combinatorial Logic for TER Flag

**CS “low” to “high” Transition**

- Command decoding is only done, when after the falling edge of CS exactly a multiple (1, 2, 3, ...) of eight SCLK signals have been detected. In case of faulty transmission, the transmission error flag (**TER**) is set and the command is ignored.
- Data from shift register is transferred into the addressed register.

**SCLK - Serial Clock**

This input pin clocks the internal shift register. The serial input (SI) transfers data into the shift register on the falling edge of SCLK while the serial output (SO) shifts diagnostic information out on the rising edge of the serial clock. It is essential that the SCLK pin is in “low” state whenever chip select CS makes any transition, otherwise the command may be not accepted.

**SI - Serial Input**

Serial input data bits are shift-in at this pin, the most significant bit first. SI information is read on the falling edge of SCLK. The input data consists of two parts, control bits followed by data bits. Please refer to **Chapter 9.5** for further information.

**SO Serial Output**

Data is shifted out serially at this pin, the most significant bit first. SO is in high impedance state until the CS pin goes to “low” state. New data will appear at the SO pin following the rising edge of SCLK.

Please refer to **Chapter 9.5** for further information.

**9.2 Daisy Chain Capability**

The SPI of BTS54040-LBA provides daisy chain capability. In this configuration several devices are activated by the same CS signal MCS. The SI line of one device is connected with the SO line of another device (see **Figure 27**), in order to build a chain. The end of the chain is connected to the output and input of the master device, MO and MI respectively. The master device provides the master clock MCLK which is connected to the SCLK line of each device in the chain.

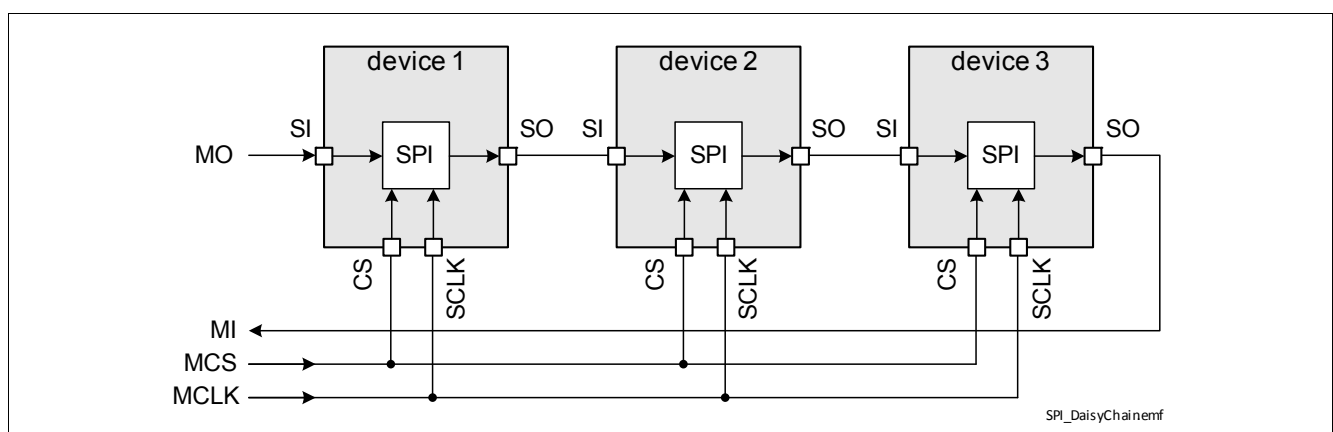

**Figure 27 Daisy Chain Configuration**

In the SPI block of each device, there is one shift register where each bit from SI line is shifted in each SCLK. The bit shifted out occurs at the SO pin. After eight SCLK cycles, the data transfer for one device is finished. In single chip configuration, the CS line must turn “high” to make the device acknowledge the transferred data. In daisy chain configuration, the data shifted out at device 1 has been shifted in to device 2. When using three devices in daisy chain, three times 8 bits have to be shifted through the devices. After that, the MCS line must turn “high” (see **Figure 28**).

Serial Peripheral Interface (SPI)

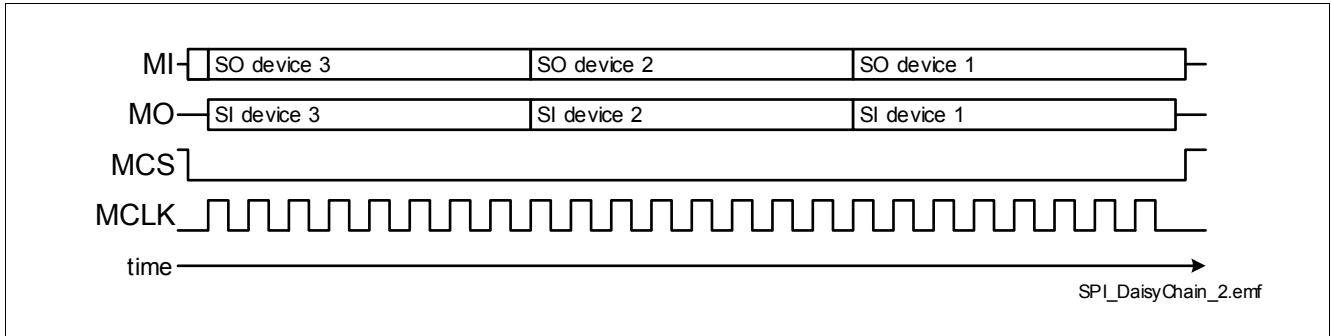

Figure 28 Data Transfer in Daisy Chain Configuration

### 9.3 Timing Diagrams

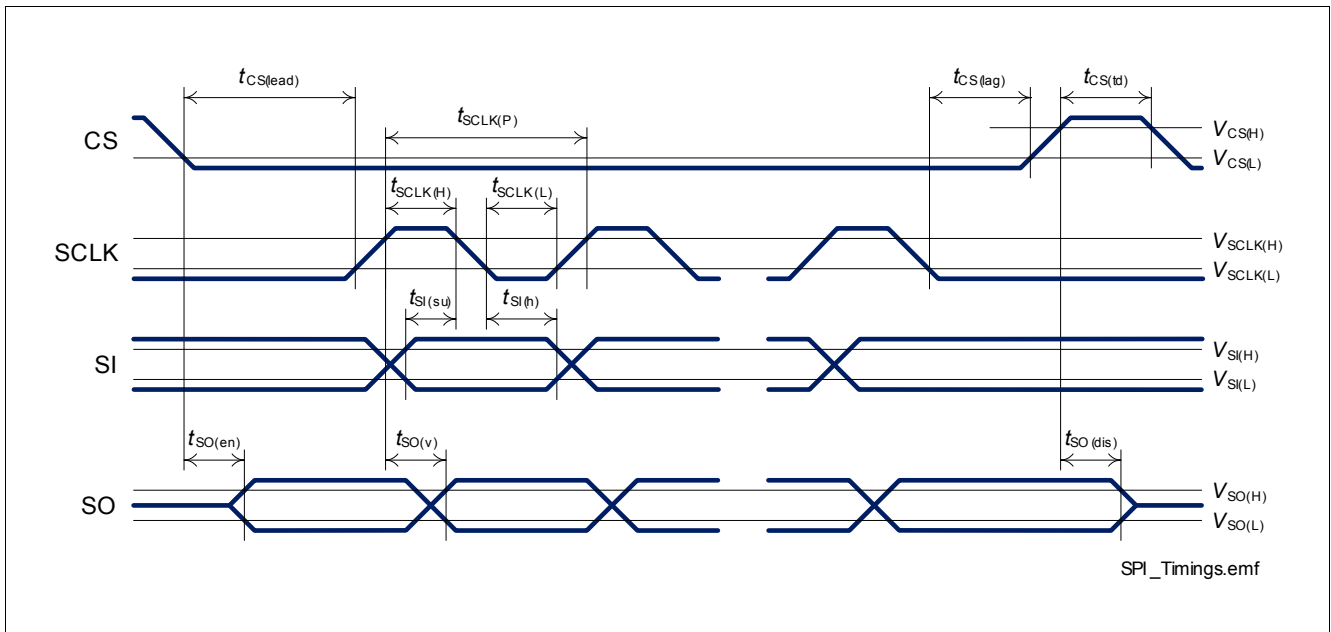

Figure 29 Timing Diagram SPI Access

## 9.4 Electrical Characteristics

Unless otherwise specified:  $V_S = 7\text{ V to }18\text{ V}$ ,  $T_j = -40\text{ °C to }+150\text{ °C}$ ,  $V_{DD} = 3.8\text{ V to }5.5\text{ V}$

Typical values:  $V_S = 13.5\text{ V}$ ,  $T_j = 25\text{ °C}$ ,  $V_{DD} = 4.3\text{ V}$

**Table 12 Electrical Characteristics Serial Peripheral Interface (SPI)**

Parameter	Symbol	Values			Unit	Note / Test Condition	Number
		Min.	Typ.	Max.			
<b>Input Characteristics (CS, SCLK, SI) - L Level of pin</b>							
CS	$V_{CS(L)}$	-0.3	–	1.0	V	$V_{DD} = 4.3\text{ V}$	P_9.4.1
SCLK	$V_{SCLK(L)}$	-0.3	–	1.0	V	$V_{DD} = 4.3\text{ V}$	P_9.4.2
SI	$V_{SI(L)}$	-0.3	–	1.0	V	$V_{DD} = 4.3\text{ V}$	P_9.4.3
<b>Input Characteristics (CS, SCLK, SI) - H Level of pin</b>							
CS	$V_{CS(H)}$	2.6	–	$V_{DD}$	V	$V_{DD} = 4.3\text{ V}$	P_9.4.4
SCLK	$V_{SCLK(H)}$	2.6	–	$V_{DD}$	V	$V_{DD} = 4.3\text{ V}$	P_9.4.5
SI	$V_{SI(H)}$	2.6	–	$V_{DD}$	V	$V_{DD} = 4.3\text{ V}$	P_9.4.6
L-input pull-up current at CS pin	$-I_{CS(L)}$	7	30	75	$\mu\text{A}$	$V_{DD} = 4.3\text{ V}$ $V_{CS} = 1.0\text{ V}$	P_9.4.7
H-input pull-up current at CS pin	$-I_{CS(H)}$	3	27	75	$\mu\text{A}$	$V_{DD} = 4.3\text{ V}$ $V_{CS} = 2.6\text{ V}$	P_9.4.8
<b>L-Input Pull-Down Current at Pin</b>							
SCLK	$I_{SCLK(L)}$	3	27	75	$\mu\text{A}$	$V_{SCLK} = 1.0\text{ V}$ $V_{DD} = 4.3\text{ V}$	P_9.4.9
SI	$I_{SI(L)}$	3	27	75	$\mu\text{A}$	$V_{SI} = 1.0\text{ V}$ $V_{DD} = 4.3\text{ V}$	P_9.4.10
<b>H-Input Pull-Down Current at Pin</b>							
SCLK	$I_{SCLK(H)}$	7	30	75	$\mu\text{A}$	$V_{SCLK} = 2.6\text{ V}$ $V_{DD} = 4.3\text{ V}$	P_9.4.11
SI	$I_{SI(H)}$	7	30	75	$\mu\text{A}$	$V_{SI} = 2.6\text{ V}$ $V_{DD} = 4.3\text{ V}$	P_9.4.12
<b>Output Characteristics (SO)</b>							
L level output voltage	$V_{SO(L)}$	0	–	0.5	V	$I_{SO} = -0.5\text{ mA}$	P_9.4.13
H level output voltage	$V_{SO(H)}$	$V_{DD} - 0.5\text{ V}$	–	$V_{DD}$	V	$I_{SO} = 0.5\text{ mA}$ $V_{DD} = 4.3\text{ V}$	P_9.4.14
Output tristate leakage current	$I_{SO(OFF)}$	-1	–	1	$\mu\text{A}$	$V_{CS} = V_{DD}$ $V_{SO} = 0\text{ V}$ $V_{SO} = V_{DD}$	P_9.4.15
<b>Timings</b>							
Enable lead time (falling CS to rising SCLK)	$t_{CS(lead)}$	200	–	–	ns	<sup>-1)</sup>	P_9.4.16
Enable lag time (falling SCLK to rising CS)	$t_{CS(lag)}$	200	–	–	ns	<sup>-1)</sup>	P_9.4.17
Transfer delay time (rising CS to falling CS)	$t_{CS(td)}$	1	–	–	$\mu\text{s}$	<sup>-1)</sup>	P_9.4.18

**Serial Peripheral Interface (SPI)**
**Table 12 Electrical Characteristics Serial Peripheral Interface (SPI) (cont'd)**

Parameter	Symbol	Values			Unit	Note / Test Condition	Number
		Min.	Typ.	Max.			
Output enable time (falling CS to SO valid)	$t_{SO(en)}$	–	–	1	$\mu\text{s}$	<sup>1)</sup> $C_L = 50 \text{ pF}$	P_9.4.19
Output disable time (rising CS to SO tristate)	$t_{SO(dis)}$	–	–	1	$\mu\text{s}$	<sup>1)</sup> $C_L = 50 \text{ pF}$	P_9.4.20
Serial clock frequency	$f_{SCLK}$	0	–	3	MHz	– <sup>1)</sup>	P_9.4.22
Serial clock period	$t_{SCLK(P)}$	333	–	–	ns	– <sup>1)</sup>	P_9.4.24
Serial clock “high” time	$t_{SCLK(H)}$	150	–	–	ns	– <sup>1)</sup>	P_9.4.26
Serial clock “low” time	$t_{SCLK(L)}$	150	–	–	ns	– <sup>1)</sup>	P_9.4.28
Data setup time (required time SI to falling SCLK)	$t_{SI(su)}$	65	–	–	ns	– <sup>1)</sup>	P_9.4.30
Data hold time (falling SCLK to SI)	$t_{SI(h)}$	65	–	–	ns	– <sup>1)</sup>	P_9.4.32
Output data valid time with capacitive load	$t_{SO(v)}$	–	–	166	ns	<sup>1)</sup> $C_L = 50 \text{ pF}$	P_9.4.34

1) Not subject to production test, specified by design



### 9.5 SPI Protocol

The relationship between SI and SO content during SPI communication is shown in [Figure 30](#). SI line represents the frame sent from the  $\mu\text{C}$  and SO line is the answer provided by BTS54040-LBA. The “(previous response)” means that the frame sent back depends on the command frame sent from the  $\mu\text{C}$  before.

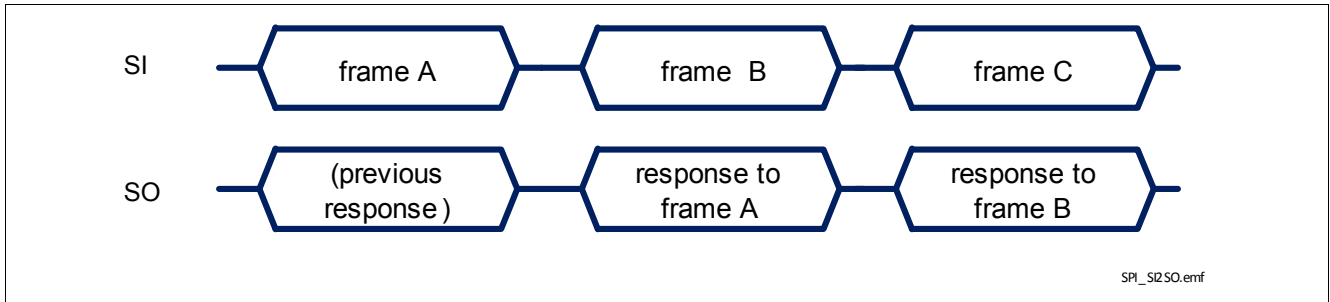

**Figure 30 Relationship between SI and SO during SPI communication**

The SPI protocol provides the answer to a command frame only with the next transmission triggered by the  $\mu\text{C}$ . Although the biggest majority of commands and frames implemented in BTS54040-LBA can be decoded without the knowledge of what happened before, it is advisable to consider what the  $\mu\text{C}$  sent in the previous transmission to decode BTS54040-LBA response frame completely.

More in detail, the sequence of commands to “read” and “write” the content of a register will look as follows:

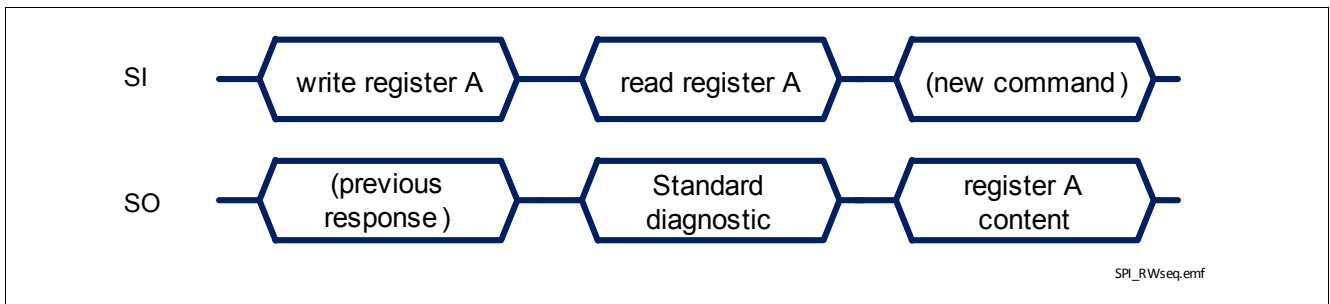

**Figure 31 Register content sent back to  $\mu\text{C}$**

There are 3 special situations where the frame sent back to the  $\mu\text{C}$  doesn't depend on the previous received frame:

- in case an error in transmission happened during the previous frame (for instance, the clock pulses were not multiple of 8), shown in [Figure 32](#)
- when BTS54040-LBA logic supply comes out of Power-On reset condition, as shown in [Figure 33](#)
- when  $V_S < V_{SMON}$  and  $\text{DCR.MUX} \neq 111_B$ , as shown in [Figure 34](#)

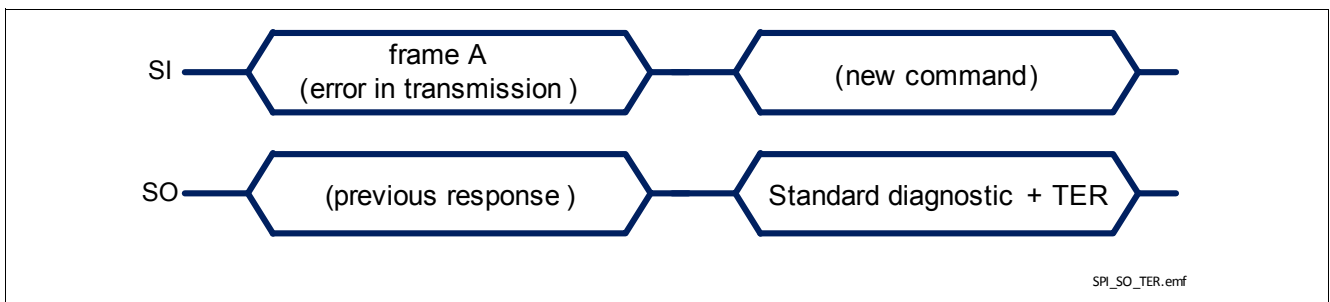

**Figure 32 BTS54040-LBA response after an error in transmission**

Serial Peripheral Interface (SPI)

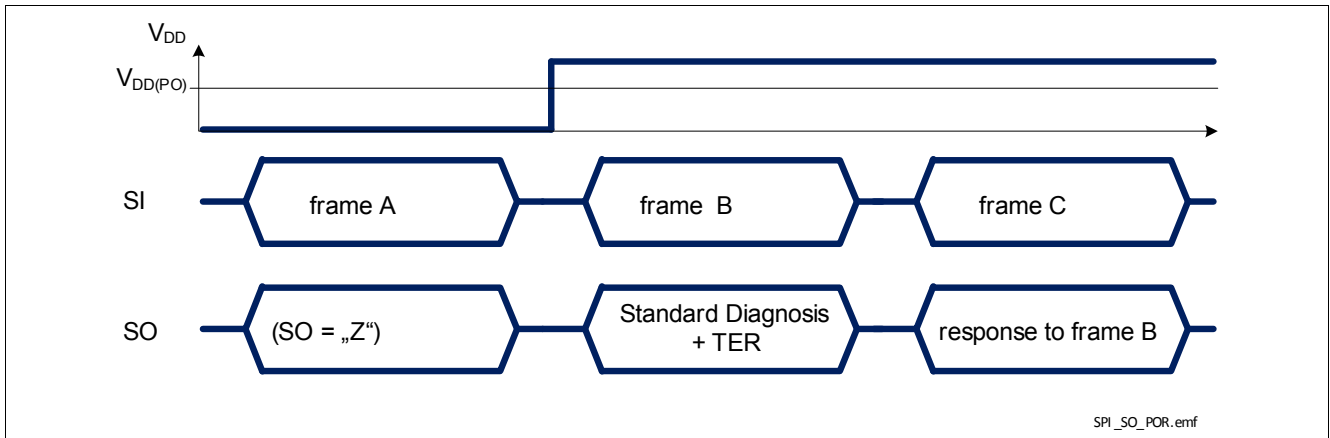

Figure 33 BTS54040-LBA response after coming out of Power-On reset at  $V_{DD}$

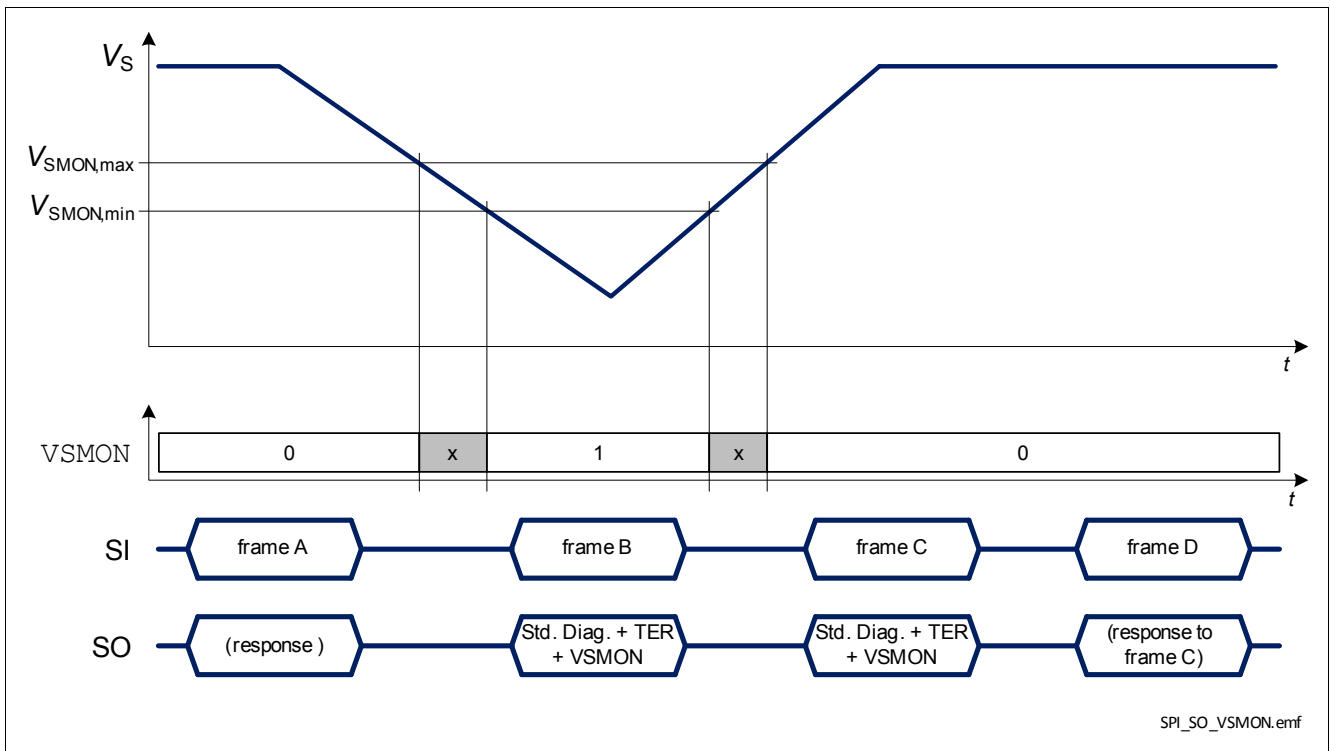

Figure 34 BTS54040-LBA response in case of a negative battery voltage transient

A summary of all possible SPI commands is presented in [Table 13](#), including the answer that BTS54040-LBA will send back at the next transmission.

Table 13 SPI Command Summary

Requested Operation	Frame sent to SPOC+ (SI pin)	Frame received from SPOC+ (SO pin) with the next command
Write <b>OUT</b> register	100xaaaa <sub>B</sub> where: "xaaaa <sub>B</sub> " = new <b>OUT</b> register content ("xx <sub>B</sub> " = don't care)	0aaaaaaaa <sub>B</sub> (Standard Diagnosis)
Read <b>OUT</b> register	00xx0000 <sub>B</sub> ("xx <sub>B</sub> " = don't care)	10aaaaaaaa <sub>B</sub> ("aaaaaa <sub>B</sub> " = <b>OUT</b> register content)
Write Configuration register	11aabb <sub>B</sub> where: "aa <sub>B</sub> " = register address "bb <sub>B</sub> " = new register content	0aaaaaaaa <sub>B</sub> (Standard Diagnosis)
Read Configuration register	01aa0000 <sub>B</sub> where: "aa <sub>B</sub> " = register address	11aabb <sub>B</sub> where: "aa <sub>B</sub> " = register address "bb <sub>B</sub> " = register content
Read Standard Diagnosis	0xxx0001 <sub>B</sub> ("xxx <sub>B</sub> " = don't care)	0aaaaaaaa <sub>B</sub> (Standard Diagnosis)
Read Errors Diagnosis	0xxx0011 <sub>B</sub> ("xxx <sub>B</sub> " = don't care)	00aaaaaaaa <sub>B</sub> (Error Diagnosis)
Read Warnings Diagnosis	0xxx0101 <sub>B</sub> ("xxx <sub>B</sub> " = don't care)	00aaaaaaaa <sub>B</sub> (Warning Diagnosis)

## 9.6 SPI Diagnosis Registers

### 9.6.1 Standard Diagnosis

SO	7	6	5	4	3	2	1	0	Default
----	---	---	---	---	---	---	---	---	---------

0	TER	LHI	STB	VSMON	ERR_MUX	50 <sub>H</sub>
---	-----	-----	-----	-------	---------	-----------------

Field	Bits	Type	Description
TER	6	r	<b>Transmission Error</b> 0 <sub>B</sub> Previous transmission was successful (modulo 8 clocks received) 1 <sub>B</sub> (default) Previous transmission failed or first transmission after reset
LHI	5	r	<b>Limp Home monitor</b> 0 <sub>B</sub> (default) Normal mode operation 1 <sub>B</sub> Limp Home Mode
STB	4	r	<b>Standby mode monitor</b> 0 <sub>B</sub> Normal mode operation 1 <sub>B</sub> (default) Stand-by mode
VSMON	3	r	<b>V<sub>S</sub> monitor</b> 0 <sub>B</sub> (default) $V_S$ always $> V_{SMON}$ since last Standard Diagnosis readout 1 <sub>B</sub> $V_S < V_{SMON}$ at least once
ERR_MUX	2:0	r	<b>Diagnosis of Channel n in error</b> 000 <sub>B</sub> (default) No channel latched OFF 001 <sub>B</sub> Channel one latched OFF 010 <sub>B</sub> Channel two latched OFF 011 <sub>B</sub> Channel three latched OFF 100 <sub>B</sub> Channel four latched OFF 101 <sub>B</sub> Not used 110 <sub>B</sub> Not used 111 <sub>B</sub> More than one channel latched OFF

### 9.6.2 Errors Diagnosis

SO	7	6	5	4	3	2	1	0	Default
	0	0	0	1	ERR_COUNTERn				10 <sub>H</sub>

Field	Bits	Type	Description
ERR_COUNTERn n = 4 to 1	3:0	r	<b>Diagnosis of Channel n</b> 0 <sub>B</sub> (default) No failure 1 <sub>B</sub> Over temperature counter reached to $n_{\text{retry}}$

### 9.6.3 Warnings Diagnosis

SO	7	6	5	4	3	2	1	0	Default
	0	0	1	0	ERRn				20 <sub>H</sub>

Field	Bits	Type	Description
ERRn n = 4 to 1	3:0	r	<b>Warning Diagnosis of Channel n</b> 0 <sub>B</sub> (default) No failure 1 <sub>B</sub> Over temperature counter > 0

## 9.7 SPI Configuration Registers

The following table provides an overview on the registers available and the available addressing space.

**Table 14 Register Overview**

Register name	Register Bank	Address	SWCR . SWR bit	Content
OUT	0	(na)	0	Output configuration
OUT	0	(na)	1	Input status
SWCR	1	00	(na)	Swap configuration
LGCR	1	01	0	LED mode configuration
LGCR	1	01	1	Gate Back Regulation configuration
HWCR	1	10	(na)	Hardware configuration
DCR	1	11	(na)	Diagnostic configuration

### 9.7.1 Output Configuration Register

SWCR . SWR = 0

Bit	7	6	5	4	3	2	1	0	
Name	$\overline{W} = 1$ $\overline{R} = 0$	RB	5	4	3	2	1	0	Default
OUT	W/R	0	0	x	OUT . OUTn				80 <sub>H</sub>

### 9.7.2 Input Status Register

SWCR . SWR = 1

Bit	7	6	5	4	3	2	1	0	
Name	$\overline{W} = 1$ $\overline{R} = 0$	RB	5	4	3	2	1	0	Default
OUT	R	0	LHI	1	OUT . INSTn				90 <sub>H</sub>

### 9.7.3 Swap Configuration Register

Bit	7	6	5	4	3	2	1	0	Default
Name	$\overline{W} = 1$ $\overline{R} = 0$	RB	ADDR		3	2	1	0	
SWCR	W/R	1	00		SWCR . SWR	1	0	0	C4 <sub>H</sub>

### 9.7.4 LED Mode Configuration Register

$SWCR.SWR = 0$

Name	$\frac{W}{R} = 1$ $\frac{R}{W} = 0$	RB	ADDR	3	2	1	0	Default
LGCR	W/R	1	01	LGCR.LEDn				D0 <sub>H</sub>

### 9.7.5 Gate Back Regulation Register

$SWCR.SWR = 1$

Name	$\frac{W}{R} = 1$ $\frac{R}{W} = 0$	RB	ADDR	3	2	1	0	Default
LGCR	W/R	1	01	LGCR.GBRn				DF <sub>H</sub>

### 9.7.6 Hardware Configuration Register

Name	$\frac{W}{R} = 1$ $\frac{R}{W} = 0$	RB	ADDR	3	2	1	0	Default
HWCR	R	1	10	HWCR.RCR	HWCR.COL	HWCR.STB	0	E2 <sub>H</sub>
	W	1	10	HWCR.RCR	HWCR.COL	HWCR.RST	HWCR.CTC	-

### 9.7.7 Diagnosis Control Register

Name	W = 1 R = 0	RB	ADDR	3	2	1	0	Default
DCR	R	1	11	DCR.SBM	DCR.MUX			F7 <sub>H</sub>
	W	1	11	0	DCR.MUX			-

### 9.7.8 Configuration Register Bit Overview

Field	Bits	Type	Description
RB	6	rw	<b>Register Bank</b> 0 <sub>B</sub> (default) Read / write to <b>OUT</b> register 1 <sub>B</sub> Read / write to other registers
OUT.OUTn n = 4 to 1	3:0	rw	<b>Output Control Register of Channel n</b> 0 <sub>B</sub> (default) channel is OFF 1 <sub>B</sub> Channel is ON
OUT.INSTn n = 4 to 1	3:0	r	<b>Input Status Monitor Channel n</b> 0 <sub>B</sub> (default) Input signal is "low" 1 <sub>B</sub> Input signal is "high"
LGCR.LEDn n = 4 to 1	3:0	rw	<b>Set LED Mode for Channel n</b> 0 <sub>B</sub> (default) Channel n is in bulb mode 1 <sub>B</sub> Channel n is in LED mode
LGCR.GBRn n = 4 to 1	3:0	rw	<b>Gate Back Regulation for Channel n</b> 0 <sub>B</sub> Gate back regulation for Channel n is forced OFF 1 <sub>B</sub> (default) Gate back regulation for Channel n is active
HWCR.CTC	0	w	<b>Clear Thermal Counter</b> 0 <sub>B</sub> (default) Thermal latches are untouched 1 <sub>B</sub> Command: Clear all thermal latches
HWCR.RST	1	w	<b>Reset Command</b> 0 <sub>B</sub> (default) Normal operation 1 <sub>B</sub> Execute reset command
HWCR.STB	1	r	<b>Standby Mode</b> 0 <sub>B</sub> Device is awake 1 <sub>B</sub> (default) Device is in Standby mode
HWCR.COL	2	rw	<b>Input Combinatorial Logic Configuration</b> 0 <sub>B</sub> (default) Input signal OR-combined with according <b>OUT</b> register bit <sup>1)</sup> 1 <sub>B</sub> Input signal AND-combined with according <b>OUT</b> register bit
HWCR.RCR	3	rw	<b>Retry Counter Reset</b> 0 <sub>B</sub> (default) Retry Counter is reset only for <b>HWCR.CTC</b> =1 (and $V_{DD}$ reset) 1 <sub>B</sub> Retry Counter is reset for every IN-pin or <b>OUT.OUTn</b> "high" to "low" transition for $n_{\text{retry}} < n_{\text{retry,max}}$ and also for <b>HWCR.CTC</b> =1 (and $V_{DD}$ reset)



Serial Peripheral Interface (SPI)

Field	Bits	Type	Description
SWCR.SWR	1	rw	<b>Switch Register</b> 0 <sub>B</sub> (default) <b>OUT.OUTn</b> and <b>LGCR.LEDn</b> can be written and read 1 <sub>B</sub> <b>OUT.INSTn</b> can be read and <b>LGCR.GBRn</b> can be written and read
DCR.SBM	3	r	<b>Switch Bypass Monitor<sup>2)</sup></b> 0 <sub>B</sub> $V_{DS} < V_{DS(SB)}$ 1 <sub>B</sub> $V_{DS} > V_{DS(SB)}$
DCR.MUX	2:0	rw	<b>Set Current Sense Multiplexer Configuration in OFF-state</b> 000 <sub>B</sub> IS pin is high impedance 001 <sub>B</sub> IS pin is high impedance 010 <sub>B</sub> IS pin is high impedance 011 <sub>B</sub> IS pin is high impedance 100 <sub>B</sub> IS pin is high impedance 101 <sub>B</sub> IS pin is high impedance 110 <sub>B</sub> IS pin is high impedance 111 <sub>B</sub> Stand-by mode (IS pin is high impedance)  <b>Set Multiplexer Configuration in ON-state</b> 000 <sub>B</sub> Current sense of channel 1 is routed to IS pin 001 <sub>B</sub> Current sense of channel 2 is routed to IS pin 010 <sub>B</sub> Current sense of channel 3 is routed to IS pin 011 <sub>B</sub> Current sense of channel 4 is routed to IS pin 100 <sub>B</sub> IS pin is high impedance 101 <sub>B</sub> IS pin is high impedance 110 <sub>B</sub> IS pin is high impedance 111 <sub>B</sub> Stand-by mode (IS pin is high impedance)

- 1) In Limp Home Mode (LHI pin set to "high") the combinatorial logic is switched to OR-mode.
- 2) The switch bypass monitor compares the threshold  $V_{DS(SB)}$  with the voltage  $V_{DS}$  across the power transistor of that channel which is selected by the current sense multiplexer (**DCR.MUX**).

## 10 Application Description

The following figure describes a typical operating circuit. It shall not be considered as a warranty of a certain functionality, condition or quality of the device. The [Table 15](#) shows suggested component values and purposes.

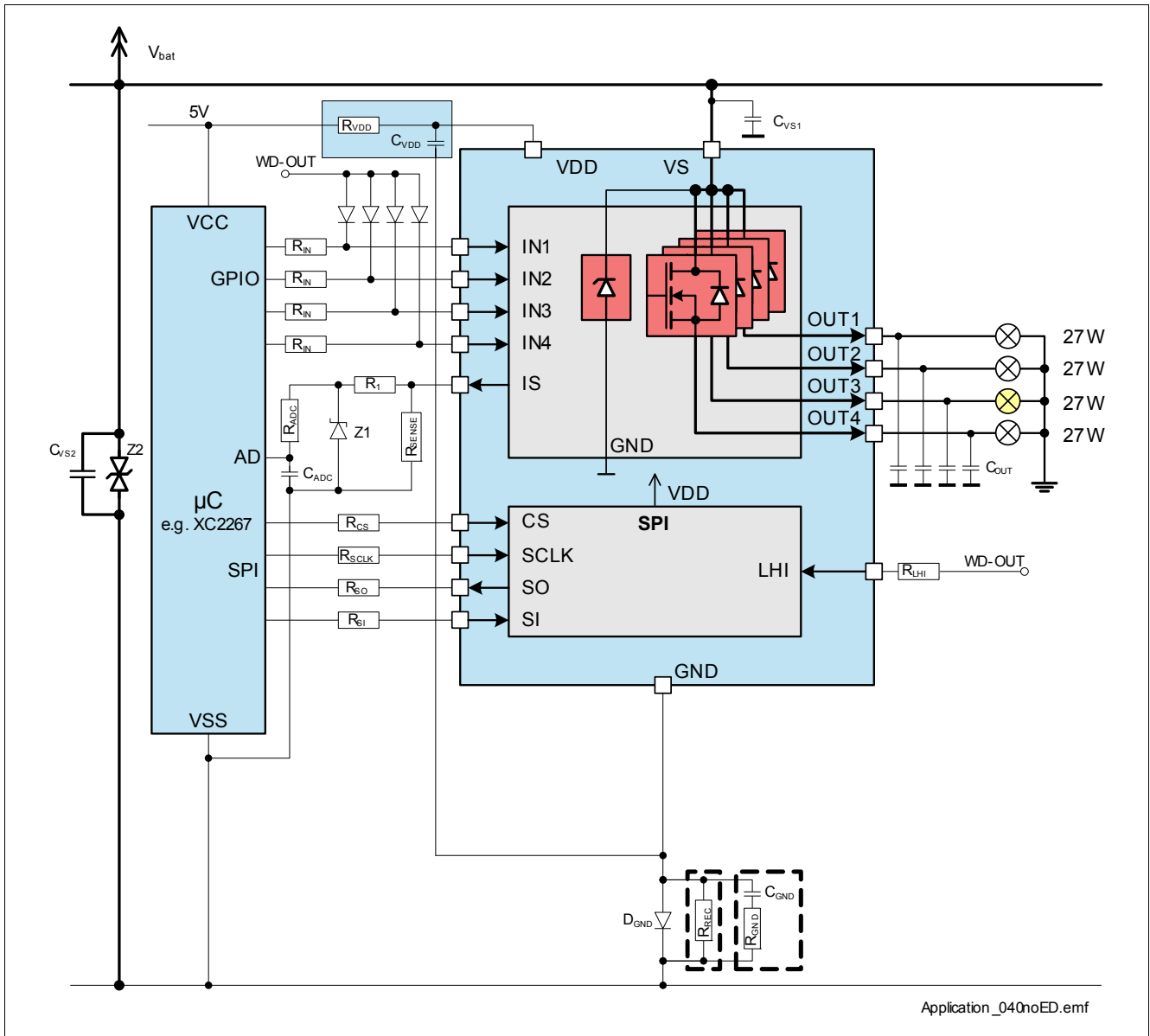

Figure 35 Application Circuit Example

**Table 15 Suggested Component Values**

Reference	Value	Purpose
$R_{VDD}$	500 $\Omega$	Device logic protection (Size 1206 recommended)
$R_{IN}$	8 k $\Omega$	Protection of the $\mu$ C during overvoltage, reverse polarity and loss of ground
$R_1$	4.7 k $\Omega$	Protection resistor for overvoltage, reverse polarity and loss of ground. Value to be tuned with $\mu$ C specification
$R_{IS}$	2.7 k $\Omega$	Sense resistor
$R_{ADC}$	1 k $\Omega$	$\mu$ C-ADC voltage spikes filtering
$R_{CS}$	3.9 k $\Omega$	Protection of the $\mu$ C during overvoltage and reverse polarity
$R_{SCLK}$	3.9 k $\Omega$	Protection of the $\mu$ C during overvoltage and reverse polarity
$R_{SO}$	3.9 k $\Omega$	Protection of the $\mu$ C during overvoltage and reverse polarity
$R_{SI}$	3.9 k $\Omega$	Protection of the $\mu$ C during overvoltage and reverse polarity
$R_{LHI}$	8 k $\Omega$	Protection of the $\mu$ C during overvoltage and reverse polarity
$C_{ADC}$	1 nF	$\mu$ C-ADC voltage spikes filtering
$C_{VDD}$	100 nF	Logic supply voltage spikes filtering
$C_{VS1}$	68 nF	Battery voltage spikes filtering
$C_{VS2}$	100 nF	Battery voltage spikes filtering
$C_{OUT}$	10 nF	For improved electromagnetic compatibility (EMC)
$C_{GND}$	8.2 nF	Ground voltage spikes filtering (optional for improved robustness against battery voltage transients)
$R_{GND}$	100 $\Omega$	Ground voltage spikes filtering (optional for improved robustness against battery voltage transients)
$R_{REC}$	1 k $\Omega$	Ground voltage recycling path (optional for providing a recycle path in case of loss of Battery)
$Z_1$	7 V	Protection of $\mu$ C during overvoltage. Zener diode
$Z_2$	P6SMB30	Protection of device during overvoltage. Zener diode
$D_{GND}$	BAS70	Protection of device during reverse polarity. Schottky diode



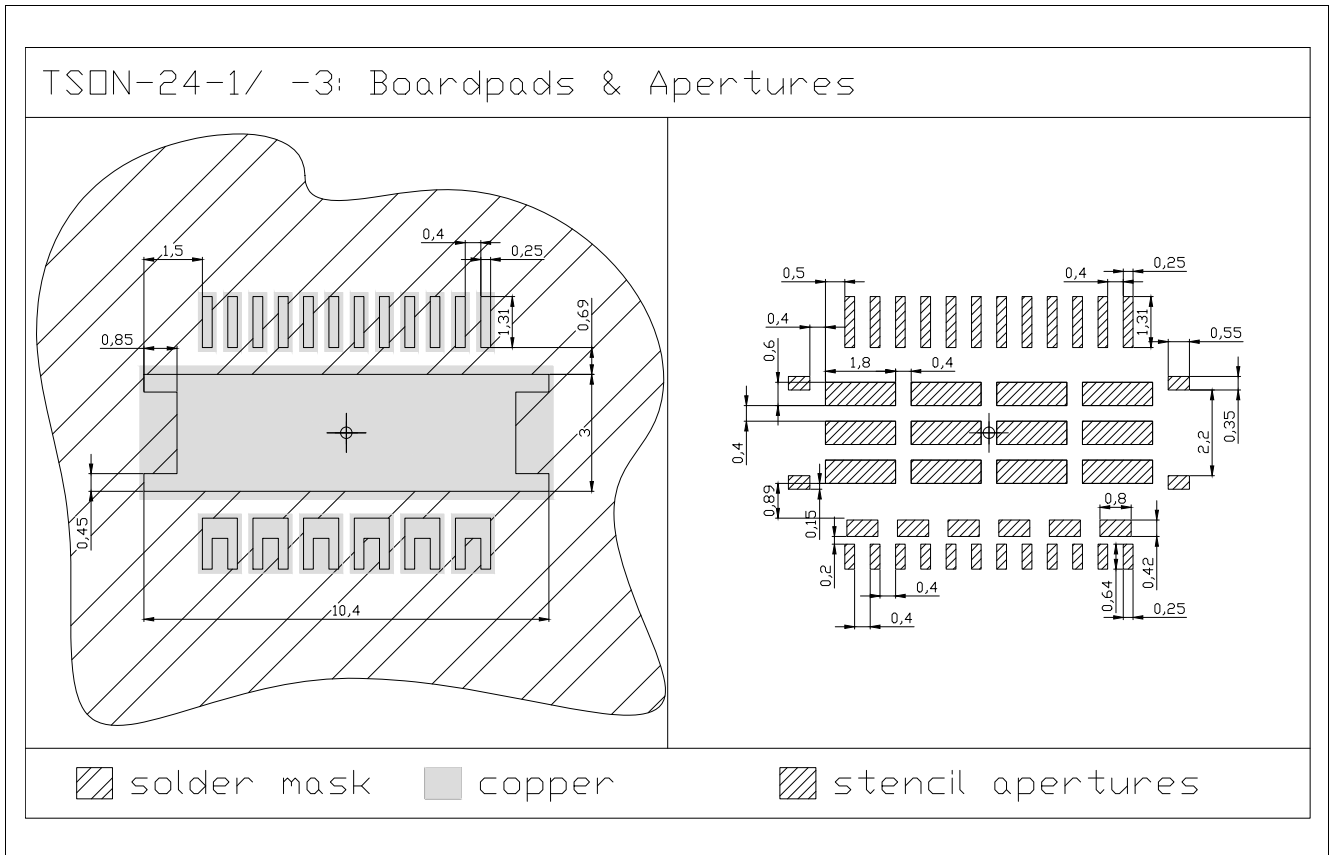

Figure 37 TSON-24 Package pads and stencil

**Green Product (RoHS Compliant)**

To meet the world-wide customer requirements for environmentally friendly products and to be compliant with government regulations the device is available as a green product. Green products are RoHS-Compliant (i.e. Pb-free finish on leads and suitable for Pb-free soldering according to IPC/JEDEC J-STD-020).

Note: You can find all of our packages, sorts of packing and others in our Infineon Internet Page "Products": <http://www.infineon.com/products>.

**Edition 2016-10-10**

**Published by  
Infineon Technologies AG  
81726 Munich, Germany**

**© 2016 Infineon Technologies AG  
All Rights Reserved.**

#### **Legal Disclaimer**

The information given in this document shall in no event be regarded as a guarantee of conditions or characteristics. With respect to any examples or hints given herein, any typical values stated herein and/or any information regarding the application of the device, Infineon Technologies hereby disclaims any and all warranties and liabilities of any kind, including without limitation, warranties of non-infringement of intellectual property rights of any third party.

#### **Legal Disclaimer for short-circuit capability**

Infineon disclaims any warranties and liabilities, whether expressed nor implied, for any short-circuit failures below the threshold limit.

#### **Information**

For further information on technology, delivery terms and conditions and prices, please contact the nearest Infineon Technologies Office ([www.infineon.com](http://www.infineon.com)).

#### **Warnings**

Due to technical requirements, components may contain dangerous substances. For information on the types in question, please contact the nearest Infineon Technologies Office.

Infineon Technologies components may be used in life-support devices or systems only with the express written approval of Infineon Technologies, if a failure of such components can reasonably be expected to cause the failure of that life-support device or system or to affect the safety or effectiveness of that device or system. Life support devices or systems are intended to be implanted in the human body or to support and/or maintain and sustain and/or protect human life. If they fail, it is reasonable to assume that the health of the user or other persons may be endangered.

## X-ON Electronics

Largest Supplier of Electrical and Electronic Components

*Click to view similar products for [Power Switch ICs - Power Distribution](#) category:*

*Click to view products by [Infineon](#) manufacturer:*

Other Similar products are found below :

[AP22652AW6-7](#) [MAPDCC0001](#) [L9349TR-LF](#) [MAPDCC0005](#) [NCP45520IMNTWG-L](#) [VND5050K-E](#) [MP6205DD-LF-P](#)  
[MC15XS3400DHFKR2](#) [FPF1015](#) [FPF1018](#) [DS1222](#) [TCK2065G,LF](#) [SZNCP3712ASNT3G](#) [L9781TR](#) [NCP45520IMNTWG-H](#)  
[MC17XS6500BEK](#) [SP2526A-1EN-L/TR](#) [SP2526A-2EN-L/TR](#) [MAX4999ETJ+T](#) [MC22XS4200BEK](#) [MAX14575BETA+T](#) [VN1160C-1-E](#)  
[VN750PEP-E](#) [TLE7244SL](#) [BTS50060-1EGA](#) [MAX1693HEUB+T](#) [MC07XSG517EK](#) [TLE7237SL](#) [MIC2033-05BYMT-T5](#) [MIC2033-](#)  
[12AYMT-T5](#) [MIC2033-05BYM6-T5](#) [MP6513LGJ-P](#) [NCP3902FCCTBG](#) [AP22811BW5-7](#) [SLG5NT1437VTR](#) [SZNCP3712ASNT1G](#)  
[NCV330MUTBG](#) [DML1008LDS-7](#) [MAX4987AEETA+T](#) [KTS1670EDA-TR](#) [MAX1694EUB+T](#) [KTS1640QGDV-TR](#) [KTS1641QGDV-TR](#)  
[IPS160HTR](#) [BTS500251TADATMA2](#) [NCV451AMNWTBG](#) [MC07XS6517BEKR2](#) [SIP43101DQ-T1-E3](#) [DML10M8LDS-13](#)  
[MAX1922ESA+C71073](#)