

# CDM10V-4

## A 0-10V Dimming Solution

### Feature list

- Simplest 0-10 V design on the market. CDM10V-4 comes with following key settings:
  - 2kHz PWM frequency
  - 100µA Dimmer/Resistor Bias current
  - Dim-to-off
- Wide input  $V_{CC}$  range from 11 to 25 V
- Replaces many external components with a single chip reducing BOM and PCB space
- Minimum variation from device to device

### Potential applications

- LED Drivers needing 0-10 V Dimming Circuits
- Industrial and Commercial Dimmable Applications:  
Luminaires, Troffers, Downlights, Sconces, Undercabinet, Office Lighting, Signage applications, Dali applications

Product Type	Package
CDM10V-4	SOT23-6

### Product validation

Qualified for applications listed above based on the test conditions in the relevant tests of JEDEC20/22.

### Description

CDM10V-4 is a fully integrated 0-10 V dimming interface IC and comes in a SOT-23-6 package to cover space requirements on small PCBs.

The device is targeted for various dimming applications in lighting. The IC can be used to transmit analog voltage based signals from a 0-10 V dimmer or potentiometer to the dimming or PWM input of a lighting controller IC in the form of a 5 mA current based PWM signal to drive an external opto-coupler. It replaces many components in a traditional solution and reduces BOM and PCB space significantly.

The CDM10V-4 IC outputs a 0 - 100% PWM current signal at 2 kHz with an amplitude value of 5 mA.

Embedded digital signal processing maintains minimum variations from device to device.

## Table of contents

	<b>Feature list</b> .....	1
	<b>Potential applications</b> .....	1
	<b>Product validation</b> .....	1
	<b>Description</b> .....	1
	<b>Table of contents</b> .....	2
<b>1</b>	<b>Block diagram reference</b> .....	3
<b>2</b>	<b>Pin configuration</b> .....	3
<b>3</b>	<b>Functional description</b> .....	4
<b>4</b>	<b>Electrical characteristics and parameters</b> .....	7
<b>5</b>	<b>Package dimensions</b> .....	9
<b>6</b>	<b>References</b> .....	11
	<b>Revision history</b> .....	11
	<b>Trademarks</b> .....	12

**Block diagram reference**

**1 Block diagram reference**

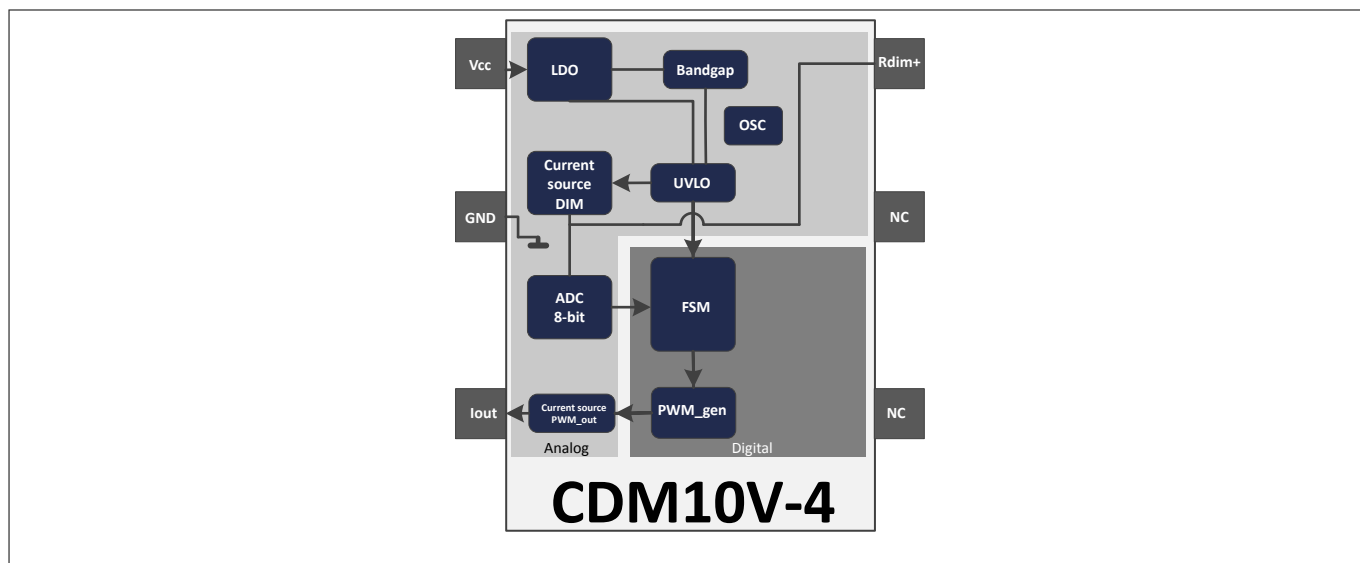

**Figure 1 Block Diagram of the CDM10V-4**

**2 Pin configuration**

**Table 1 Pin configuration**

Pin	Name	Function
1	V <sub>CC</sub>	Input supply voltage
2	GND	GND
3	I <sub>out</sub>	PWM output current
4	NC	GND
5	NC	GND
6	R <sub>dim+</sub>	Dimmer current output /Voltage sense

**Functional description**

**3 Functional description**

**Typical Application Circuit**

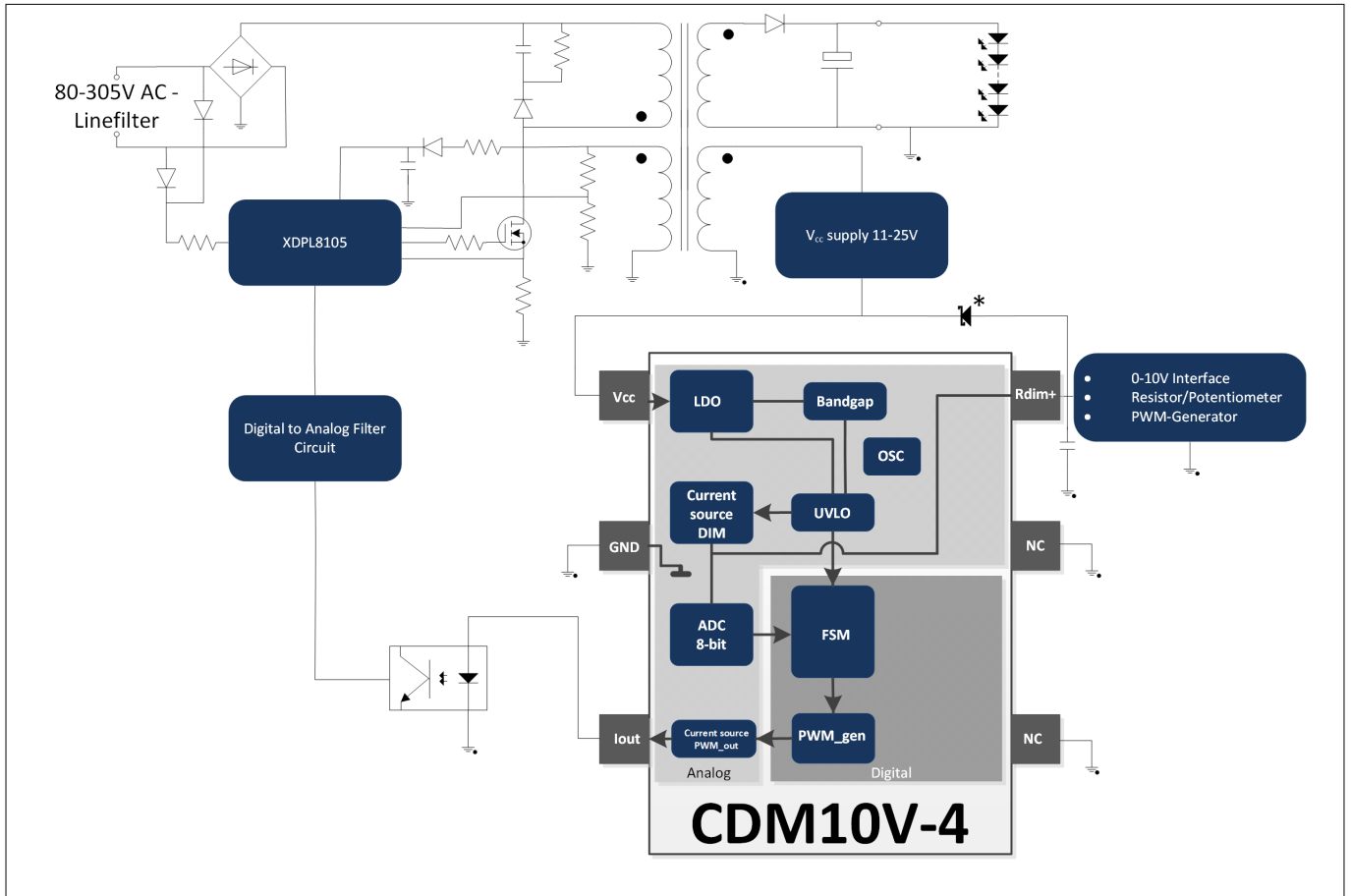

**Figure 2 Typical Application Circuit**

*Note:* The Diode marked with \* is for the protection of the  $R_{dim+}$ -Pin when active dimming is used. This is because the voltage on this Pin is not allowed to be higher than  $V_{CC}+0.5V$ . It is advised to use a low leakage, low reverse current Schottky-Diode in order to not influence the dimming performance (e.g. MMSD301T1G).

*Note:* The capacitor connected to the  $R_{dim-}$ -Pin reduces the amount of coupled noise to the dimming signal. The size of this capacitance should be in the range of 2.2 - 10 nF (typ. 4.7 nF), where a small capacitor allows steeper edges of the dimming signal, a larger capacitor enhances the noise reduction.

**Recommended cooling area**

In order to guarantee the full functionality of the CDM10V-4 device, the required cooling area has to be selected according to the graph in [Figure 3](#).

**Functional description**

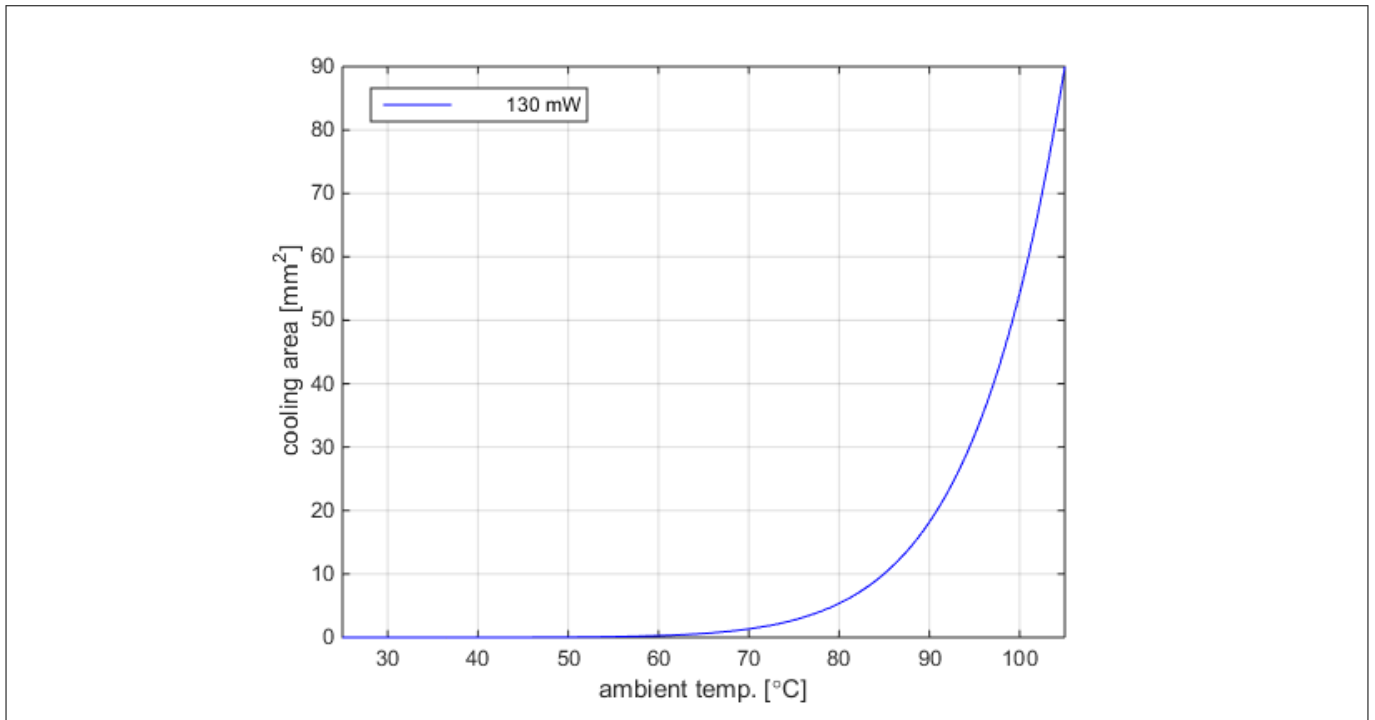

**Figure 3 Cooling area over ambient temperature CDM10V-4**

**Functional description**

**Dimming Characteristic**

**Table 2** PWM Output current referring to  $R_{dim+}$ -Pin Voltage

$R_{dim+}$	$I_{out}$
<1 V	Dim-to-Off
1 - 9 V	1...100% (@ 9V)
>9V (max. applicable Voltage: $V_{CC}$ )	Always active

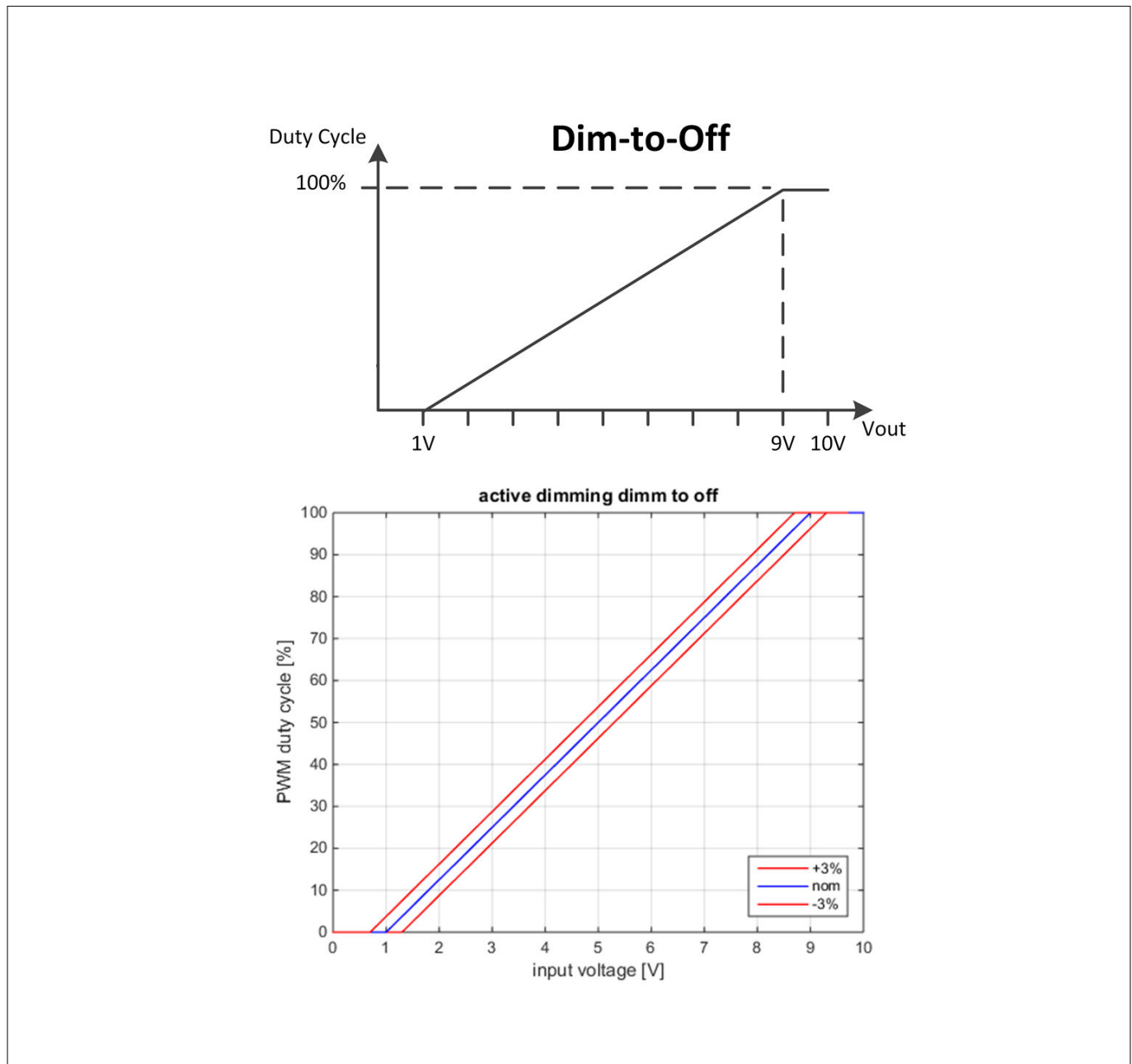

**Figure 4** Dimming Characteristic

Electrical characteristics and parameters

## 4 Electrical characteristics and parameters

**Table 3 Absolute Maximum Ratings**

Pin	Name	Values		Unit	Note or Test Condition
		Min.	Max.		
1	V <sub>CC</sub>	11	25	V	
2	GND	0	0	V	Point of reference
3	I <sub>out</sub>	-0.5	3.63	V	Depending on the optocoupler voltage @ 5mA
4	NC	-0.25	0.1	V	Connect to GND during operation
5	NC	-0.25	0.1	V	Connect to GND during operation
6	R <sub>dim+</sub>	-0.5	V <sub>CC</sub> + 0.5	V	An applied voltage above max value leads to the destruction of the device. Also valid if V <sub>CC</sub> is 0 V.

Absolute maximum ratings (**Table 3**) are defined as ratings which when being exceeded may lead to destruction of the integrated circuit. Exposure to absolute maximum rating conditions for extended periods may affect device reliability. Maximum ratings are absolute ratings; exceeding only one of these values may cause irreversible damage to the integrated circuit. These values are not tested during production test.

**Table 4 Electrical Characteristics**

Parameter	Symbol	Values			Unit	Note or Test Condition
		Min.	Typ.	Max.		
Input Voltage	V <sub>in</sub>	11		25	V	Operating Voltage
Junction Temperature Range	T <sub>J</sub>	-40		135	°C	
Ambient Temperature Range	T <sub>A</sub>	-40		105	°C	
Power Dissipation	P <sub>tot</sub>	6.05 @ 1% duty cycle;	130 @ 100% duty cycle 54 @ 50% duty cycle	160 @ 100% PWM & 25 V <sub>in</sub>	mW	Dimmer current included
Current Consumption	I <sub>CC</sub>			1	mA	Current Consumption of the IC for self supply
Output Current for Dimmer	I <sub>dim</sub>	-10%	100	+10%	µA	Current flow out of R <sub>dim+</sub> -Pin
Output Current for Optocoupler	I <sub>out</sub>	-10%	5	+10%	mA	

**Electrical characteristics and parameters**

**Table 4 Electrical Characteristics (continued)**

Parameter	Symbol	Values			Unit	Note or Test Condition
		Min.	Typ.	Max.		
Dimming accuracy		-3		+3	%	With active dimming incl. all variations
PWM frequency	$f_{\text{PWM}}$	-6%	2000	+6%	Hz	
Wake-up Time	$t_w$			40	$\mu\text{s}$	Time from $V_{\text{CC}} = 11\text{ V}$ to first output current
ESD capability HBM	$V_{\text{HBM}}$			1500	V	according to ANSI/ESDA/JEDEC JS-001
ESD capability CDM	$V_{\text{CDM}}$			500		according to JESD22 C101



Package dimensions

# 5 Package dimensions

Package Drawings

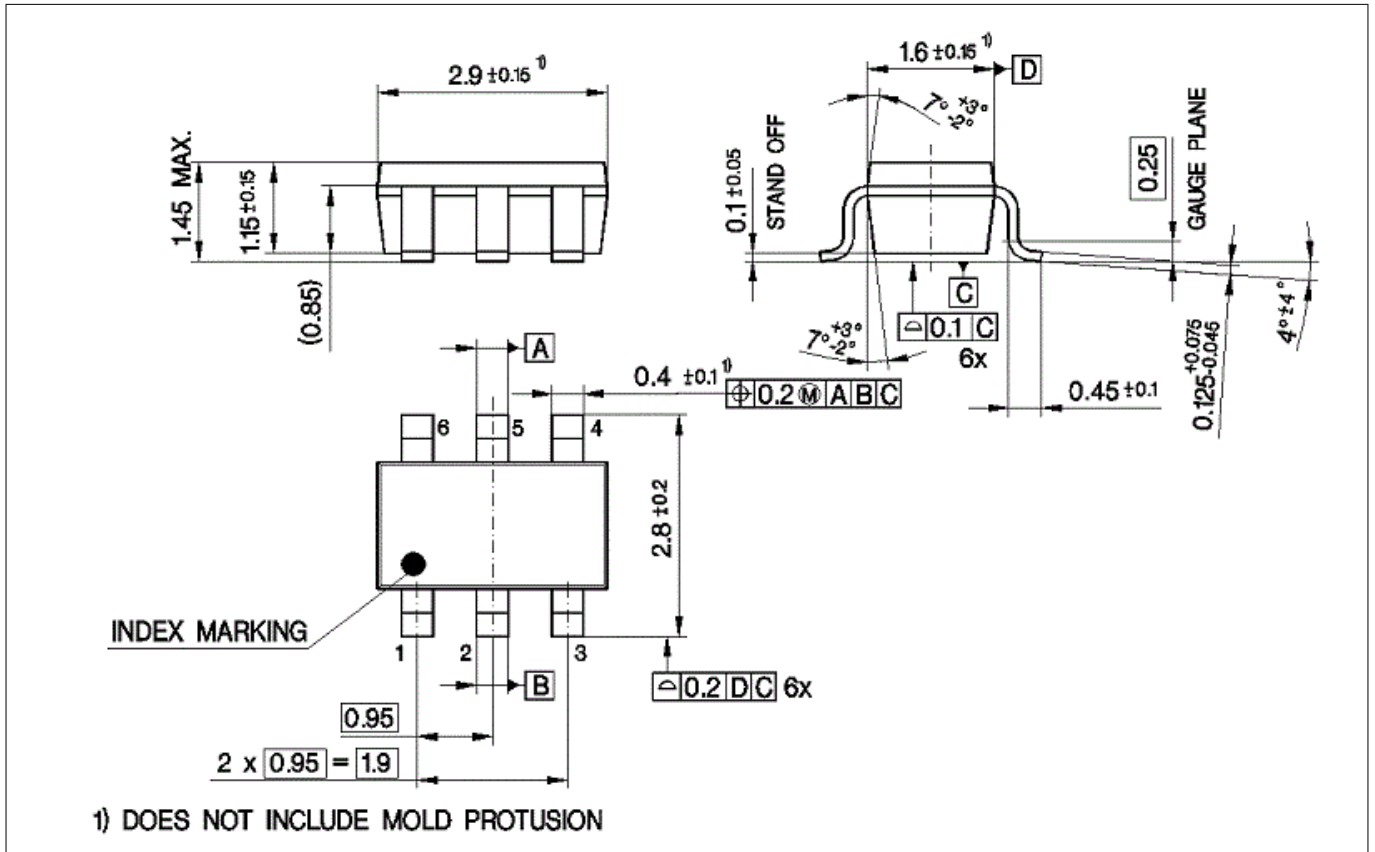
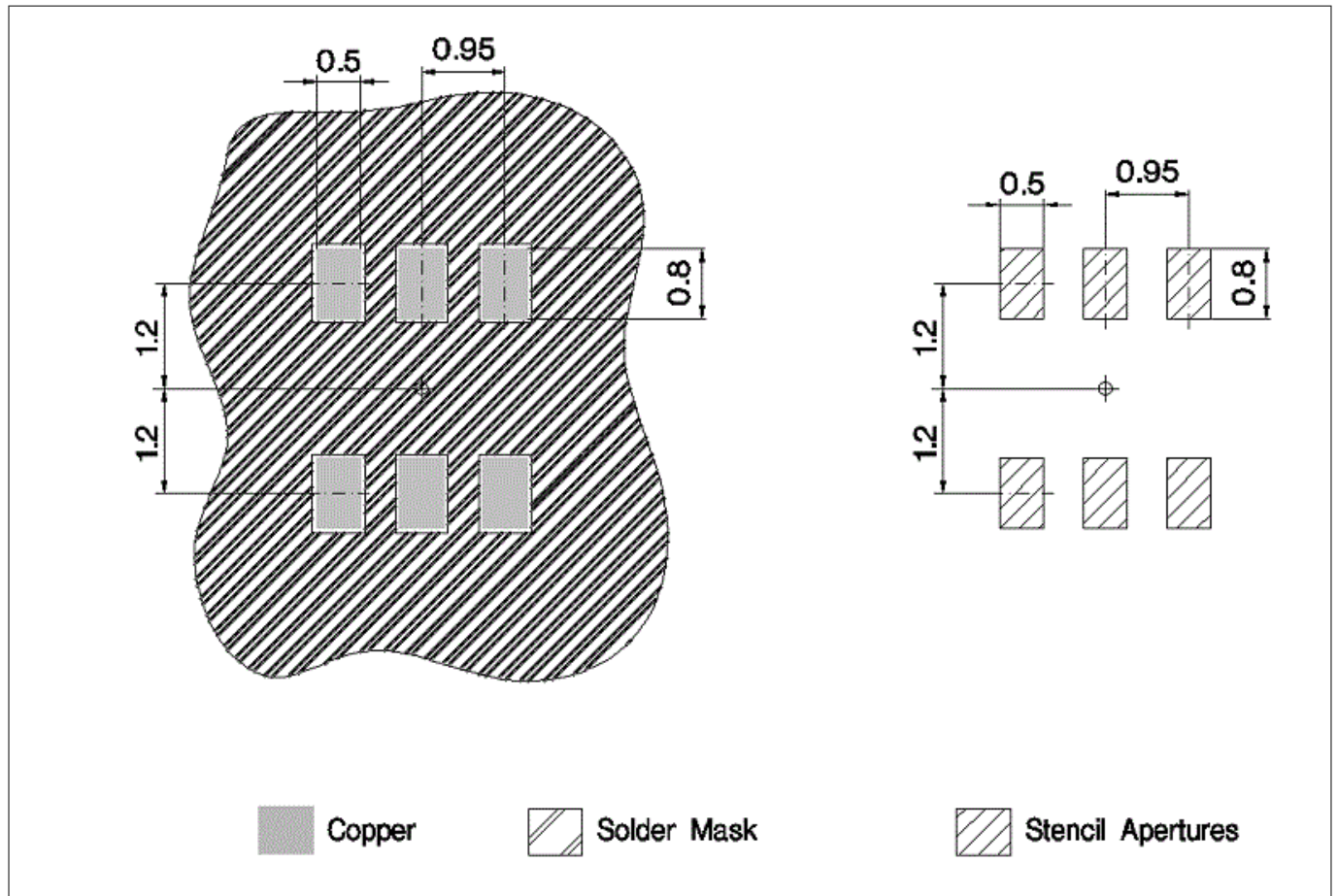

Figure 5 Package Drawings

**Package dimensions**

**Footprint**

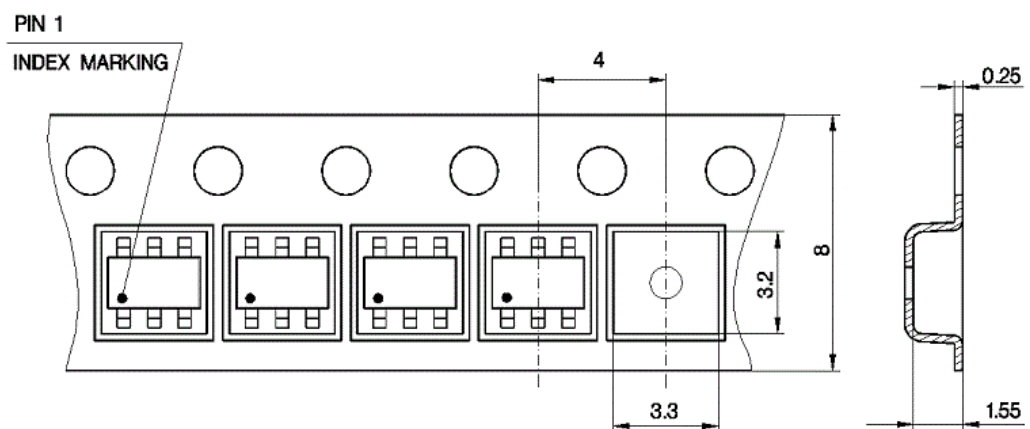

**Figure 6 Footprint**

**Packing Description**

**Packing Type**

Tape and Reel  
 Ø Reel: 180  
 Pieces / Reel: 3000  
 Reels / Box: 1



**Figure 7 Packing**

---

**References**

## **6 References**

Additional support material can be found under the following link.

**Related information**

<http://www.infineon.com/CDM10V>

## **Revision history**

<b>Document version</b>	<b>Date of release</b>	<b>Description of changes</b>
1.0	14.07.2017	<ul style="list-style-type: none"><li>Initial Version</li></ul>
1.1	04.08.2017	<ul style="list-style-type: none"><li>Changed misleading picture (figure 4 )</li></ul>

## Trademarks

All referenced product or service names and trademarks are the property of their respective owners.

**Edition 2017-08-04**

**Published by**  
**Infineon Technologies AG**  
**81726 Munich, Germany**

**© 2017 Infineon Technologies AG**  
**All Rights Reserved.**

**Do you have a question about any aspect of this document?**  
**Email: [erratum@infineon.com](mailto:erratum@infineon.com)**

**Document reference**  
**IFX-src1499941097267**

## IMPORTANT NOTICE

The information given in this document shall in no event be regarded as a guarantee of conditions or characteristics ("Beschaffheitsgarantie").

With respect to any examples, hints or any typical values stated herein and/or any information regarding the application of the product, Infineon Technologies hereby disclaims any and all warranties and liabilities of any kind, including without limitation warranties of non-infringement of intellectual property rights of any third party.

In addition, any information given in this document is subject to customer's compliance with its obligations stated in this document and any applicable legal requirements, norms and standards concerning customer's products and any use of the product of Infineon Technologies in customer's applications.

The data contained in this document is exclusively intended for technically trained staff. It is the responsibility of customer's technical departments to evaluate the suitability of the product for the intended application and the completeness of the product information given in this document with respect to such application.

## WARNINGS

Due to technical requirements products may contain dangerous substances. For information on the types in question please contact your nearest Infineon Technologies office.

Except as otherwise explicitly approved by Infineon Technologies in a written document signed by authorized representatives of Infineon Technologies, Infineon Technologies' products may not be used in any applications where a failure of the product or any consequences of the use thereof can reasonably be expected to result in personal injury

## X-ON Electronics

Largest Supplier of Electrical and Electronic Components

*Click to view similar products for [LED Lighting Drivers](#) category:*

*Click to view products by [Infineon](#) manufacturer:*

Other Similar products are found below :

[LV5235V-MPB-H](#) [MB39C602PNF-G-JNEFE1](#) [MIC2871YMK-T5](#) [AL1676-10BS7-13](#) [AL1676-20AS7-13](#) [AP5726WUG-7](#) [MX877RTR](#)  
[ICL8201](#) [IS31BL3228B-UTLS2-TR](#) [IS31BL3506B-TTLS2-TR](#) [AL3157F-7](#) [AP5725FDCG-7](#) [AP5726FDCG-7](#) [LV52204MTTBG](#)  
[AP5725WUG-7](#) [STP4CMPQTR](#) [NCL30086BDR2G](#) [CAT4004BHU2-GT3](#) [LV52207AXA-VH](#) [AP1694AS-13](#) [TLE4242EJ](#) [AS3688](#)  
[IS31LT3172-GRLS4-TR](#) [TLD2311EL](#) [KTD2694EDQ-TR](#) [KTZ8864EJAA-TR](#) [IS32LT3174-GRLA3-TR](#) [ZXLD1374QESTTC](#) [MP2488DN-](#)  
[LF-Z](#) [NLM0010XTSA1](#) [AL1676-20BS7-13](#) [MPQ7220GF-AEC1-P](#) [MPQ7220GF-AEC1-Z](#) [MPQ4425BGJ-AEC1-Z](#) [IS31FL3737B-QFLS4-](#)  
[TR](#) [IS31FL3239-QFLS4-TR](#) [KTD2058EUAC-TR](#) [KTD2037EWE-TR](#) [DIO5662ST6](#) [IS31BL3508A-TTLS2-TR](#) [MAX20052CATC/V+](#)  
[MAX25606AUP/V+](#) [BD6586MUV-E2](#) [BD9206EFV-E2](#) [BD9416FS-E2](#) [LYT4227E](#) [LYT6079C-TL](#) [MP3394SGF-P](#) [MP4689AGN-P](#)  
[MPQ4425AGQB-AEC1-Z](#)