

Radiation hardened, 2-Mbit Serial (SPI) F-RAM

Radiation performance

- Radiation data
 - Total dose = 150 Krad (50 rad(Si)/s)
200 Krad (10 rad(Si)/s)
 - Heavy Ion soft error rate immune up to 114LET
 - Heavy Ion single event functional interrupt $< 1.34 \times 10^{-4}$ upsets/device-day (GEO - solar min)
 - Dose rate = 1.1×10^8 rad(Si)/sec (dynamic)/ 1.1×10^{11} rad(Si)/sec (static)
 - Dose rate survivability (rad(Si)/sec) = 1.1×10^{11} rad(Si)/sec
 - Latch-up immunity = 114 MeV.cm²/mg (115 °C)
- Prototyping options
 - Non-qualified CYPT15B102Q devices with same functional and timing characteristics in a 16-pin ceramic SOP package

Features

- 2-Mbit ferroelectric random access memory (F-RAM) logically organized as 256K × 8
 - High-endurance 10 trillion (10¹³) read/writes
 - 121-year data retention at 85 °C (See [Data retention and endurance on page 22](#))
 - NoDelay™ writes
- Fast serial peripheral interface (SPI)
 - Up to 25-MHz frequency
 - Direct hardware replacement for serial flash and EEPROM
- Sophisticated write protection scheme
 - Hardware protection using the write protect ($\overline{\text{WP}}$) pin
 - Software protection using write disable instruction
 - Software block protection for 1/4, 1/2, or entire array
- Device ID
 - Manufacturer ID and product ID
- Low power consumption (pre-/post 150krad TID radiation)
 - 10-mA/10-mA active current at 25 MHz
 - 850-μA/5-mA standby current
 - 25-μA/8mA sleep mode current
- Low-voltage operation: $V_{\text{DD}} = 2.0 \text{ V to } 3.6 \text{ V}$
- Military temperature: -55 °C to +125 °C
- 16-pin ceramic SOP package

Functional description

The CYRS15B102Q is a 2-Mbit nonvolatile memory employing an advanced ferroelectric process. F-RAM is nonvolatile and performs reads and writes similar to a RAM. It provides reliable data retention for 121 years at 85 °C while eliminating the complexities, overhead, and system-level reliability problems caused by serial flash, EEPROM, and other nonvolatile memories.

Unlike serial flash and EEPROM, CYRS15B102Q performs write operations at bus speed. No write delays are incurred. Data is written to the memory array immediately after each byte is successfully transferred to the device. The next bus cycle can commence without the need for data polling. In addition, the product offers substantial write endurance compared with other nonvolatile memories. CYRS15B102Q is capable of supporting 10^{13} read/write cycles, or 10 million times more write cycles than EEPROM.

The CYRS15B102Q device provides substantial benefits to users of serial EEPROM or flash as a hardware drop-in replacement. CYRS15B102Q uses the high-speed SPI bus, which enhances the high-speed write capability of F-RAM technology. The device incorporates a read-only Device ID that allows the host to determine the manufacturer, product density, and product revision. The device specifications are guaranteed over a military temperature range of -55 °C to +125 °C.

Logic block diagram

Logic block diagram

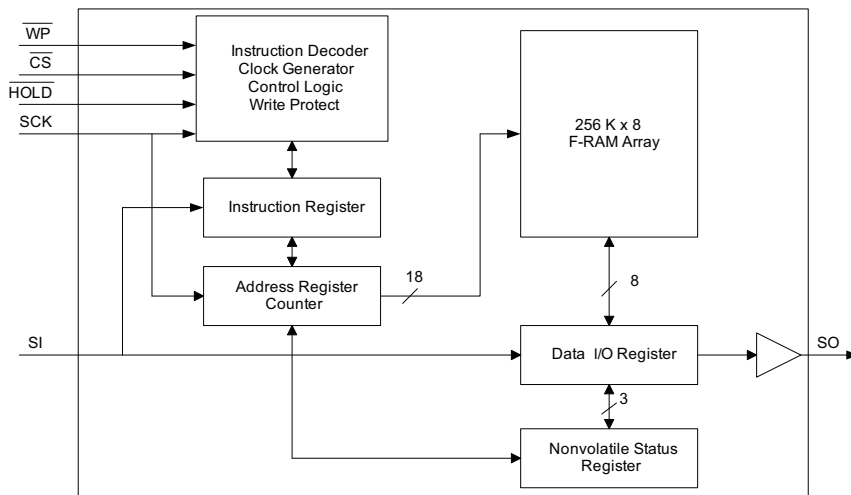

Table of contents

Pinout	5
Pin definitions	6
Manufacturing flow	7
Functional overview	8
Memory architecture	8
Serial peripheral interface - SPI bus	8
SPI overview	8
Terms used in SPI protocol	8
SPI modes	10
Power up to first access	11
Functional description	12
Command structure	12
Endurance	18
Qualification and screening	19
Single event functional interrupt elimination	19
Electrical characteristics	20
Maximum ratings	20
Operating range	20
DC electrical characteristics	21
Data retention and endurance	22
Capacitance	22
Thermal resistance	22
AC test conditions	22
AC switching characteristics	23
Power cycle timing	25
Ordering information	26
Ordering code definitions	26
Package diagrams	27
Acronyms	28
Document conventions	29
Units of measure	29
Revision history	30

1 Pinout

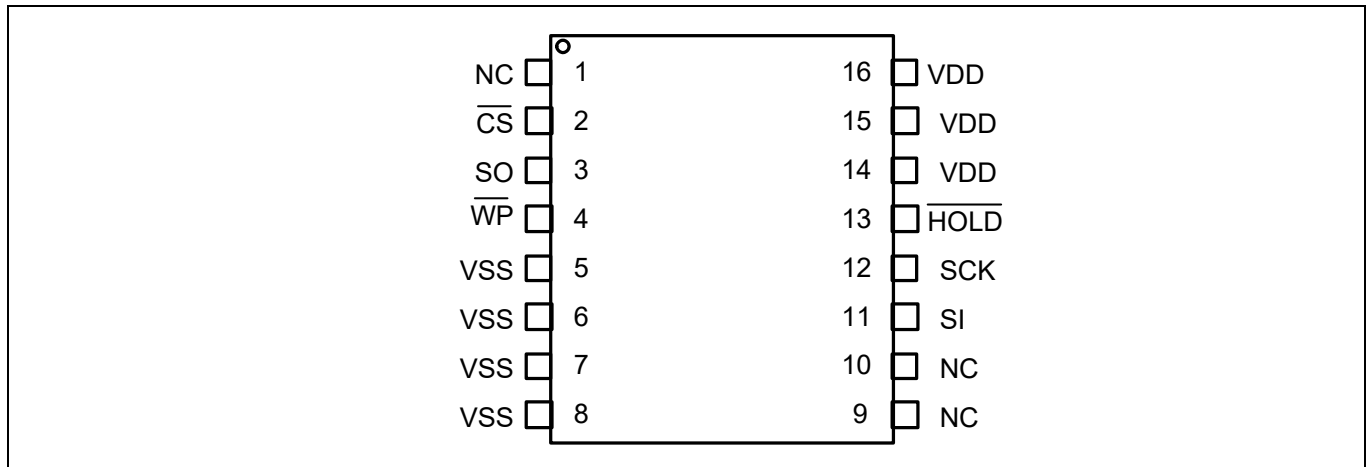

Figure 1 16-pin ceramic SOP pinout

2 Pin definitions

Table 1 Pin definitions

Pin name	I/O type	Description
SCK	Input	Serial clock. All I/O activity is synchronized to the serial clock. Inputs are latched on the rising edge and outputs occur on the falling edge. Because the device is synchronous, the clock frequency may be any value between 0 and 25 MHz and may be interrupted at any time.
$\overline{\text{CS}}$	Input	Chip select. This active LOW input activates the device. When HIGH, the device enters the low-power standby mode, ignores other inputs, and the output is tristated. When LOW, the device internally activates the SCK signal. A falling edge on CS must occur before every opcode.
SI ^[1]	Input	Serial input. All data is input to the device on this pin. The pin is sampled on the rising edge of SCK and is ignored at other times. It should always be driven to a valid logic level to meet IDD specifications.
SO ^[1]	Output	Serial output. This is the data output pin. It is driven during a read and remains tristated at all other times including when HOLD is LOW. Data transitions are driven on the falling edge of the serial clock.
$\overline{\text{WP}}$	Input	Write protect. This active LOW pin prevents write operation to the status register when WPEN is set to '1'. This is critical because other write protection features are controlled through the status register. This pin must be tied to V _{DD} if not used. See Status register and write protection on page 13 for an explanation on write protection.
HOLD	Input	HOLD pin. The HOLD pin is used when the host CPU must interrupt a memory operation for another task. When HOLD is LOW, the current operation is suspended. The device ignores any transition on SCK or $\overline{\text{CS}}$. All transitions on HOLD must occur while SCK is LOW. This pin must be tied to V _{DD} if not used.
V _{SS}	Power supply	Ground pins for the device. All V _{SS} pins must be connected with shortest trace in the board for normal operation. V _{SS} must be connected to the ground of the system.
V _{DD}	Power supply	Power supply input pins to the device. All V _{DD} pins must be connected with shortest trace in the board for normal operation.

Note

1. SI may be connected to SO for a single-pin data interface.

Manufacturing flow

3 Manufacturing flow

Table 2 Manufacturing flow

Step	Screen	Method	Requirement
1	Wafer lot acceptance test	TM 5007	–
2	Internal visual	TM 2010, Condition A	100%
3	Serialization		100%
4	Temperature cycling	TM 1010, Condition C, 50 cycles minimum	100%
5	Constant acceleration	TM 2001, Y1 orientation only	100%
6		Condition TBD (package in design)	
7	Particle impact noise detection (PIND)	TM 2020, Condition A	100%
8	Radiographic (X-ray)	TM 2012, one view (Y-1 orientation) only	
9	Pre burn in electrical parameters	In accordance with applicable Infineon specification	100%
10	Static burn in	TM 1015, Condition C 72 hours at 125 °C each polarity, 144 hours total	100%
11	Interim (post static burn in) electricals	In accordance with applicable Infineon device specifications	100%
12	Dynamic burn in	TM 1015, Condition D, 240 hours at 125 °C	100%
13	Interim (post Dynamic burn in) electricals	In accordance with applicable Infineon device specifications	100%
14	Final electrical test (1) 25 °C	In accordance with applicable Infineon device specifications TM 5005, Table I, Subgroup 1, 2, 3, 7, 8a, 8b, 9	100%
	Percent defective allowable (PDA) calculation	5% overall, 3% functional parameters at 25 °C	All lots
	(2) –55 °C and +125 °C	TM 5005, Table I, Subgroup 1, 2, 3, 7, 8a, 8b, 9	
15	Seal (fine and gross leak test)	TM 1014	100%
16	External visual	TM 2009	100%
17	QCI - Group A	MIL-PRF 38535 , Table III	All lots
18	QCI - Group B	MIL-PRF 38535 , Table II	All lots
19	QCI - Group C (1000 hour life test)	MIL-PRF 38535 , Table IV	All wafer lots
20	QCI - Group D	MIL-PRF 38535 , Table V	Every 12mo
19	Radiation lot acceptance test (Group E)	TM 1019, MIL-HDBK-714	All wafer lots

4 Functional overview

CYRS15B102Q is a serial F-RAM memory device. The memory array is logically organized as $262,144 \times 8$ bits and is accessed using an industry-standard SPI bus. The functional operation of F-RAM is similar to serial flash and serial EEPROMs. The major difference between CYRS15B102Q and serial flash or EEPROM with the same pinout is F-RAM's superior write performance, high endurance, and low power consumption.

4.1 Memory architecture

When accessing CYRS15B102Q, the user addresses 256K locations of eight data bits each. These eight data bits are shifted in or out serially. The addresses are accessed using the SPI protocol, which includes a chip select (to permit multiple devices on the bus), an opcode, and a three-byte address. The upper 6 bits of the address range are 'don't care' values. The complete address of 18 bits specifies each byte address uniquely.

Most functions of the CYRS15B102Q are either controlled by the SPI interface or are handled by on-board circuitry. The access time for the memory operation is essentially zero, beyond the time needed for the serial protocol. That is, the memory is read or written at the speed of the SPI bus. Unlike a serial flash or EEPROM, it is not necessary to poll the device for a ready condition because writes occur at bus speed. By the time a new bus transaction can be shifted into the device, a write operation is complete. This is explained in more detail in the interface section.

4.2 Serial peripheral interface - SPI bus

CYRS15B102Q is an SPI slave device and operates at speeds up to 25 MHz. This high-speed serial bus provides high-performance serial communication to an SPI master. Many common microcontrollers have hardware SPI ports allowing a direct interface. It is quite simple to emulate the port using ordinary port pins for microcontrollers that do not. The CYRS15B102Q operates in SPI modes 0 and 3.

4.3 SPI overview

The SPI is a four-pin interface with chip select (\overline{CS}), serial input (SI), serial output (SO), and serial clock (SCK) pins.

The SPI is a synchronous serial interface, which uses clock and data pins for memory access and supports multiple devices on the data bus. A device on the SPI bus is activated using the \overline{CS} pin.

The relationship between chip select, clock, and data is dictated by the SPI mode. This device supports SPI modes 0 and 3. In both of these modes, data is clocked into the F-RAM on the rising edge of SCK starting from the first rising edge after \overline{CS} goes active.

The SPI protocol is controlled by opcodes. These opcodes specify the commands from the bus master to the slave device. After \overline{CS} is activated, the first byte transferred from the bus master is the opcode. Following the opcode, any addresses and data are then transferred. The \overline{CS} must go inactive after an operation is complete and before a new opcode can be issued.

4.4 Terms used in SPI protocol

The commonly used terms in the SPI protocol are as follows:

4.4.1 SPI master

The SPI master device controls the operations on an SPI bus. An SPI bus may have only one master with one or more slave devices. All the slaves share the same SPI bus lines and the master may select any of the slave devices using the \overline{CS} pin. All of the operations must be initiated by the master activating a slave device by pulling the \overline{CS} pin of the slave LOW. The master also generates the SCK and all the data transmission on SI and SO lines are synchronized with this clock.

4.4.2 SPI slave

The SPI slave device is activated by the master through the chip select line. A slave device gets the SCK as an input from the SPI master and all the communication is synchronized with this clock. An SPI slave never initiates a communication on the SPI bus and acts only on the instruction from the master.

CYRS15B102Q operates as an SPI slave and may share the SPI bus with other SPI slave devices.

4.4.3 Chip select (\overline{CS})

To select any slave device, the master needs to pull down the corresponding \overline{CS} pin. Any instruction can be issued to a slave device only while the \overline{CS} pin is LOW. When the device is not selected, data through the SI pin is ignored and the serial output pin (SO) remains in a high-impedance state.

Note A new instruction must begin with the falling edge of \overline{CS} . Therefore, only one opcode can be issued for each active chip select cycle.

4.4.4 Serial clock (SCK)

The serial clock is generated by the SPI master and the communication is synchronized with this clock after \overline{CS} goes LOW.

CYRS15B102Q enables SPI modes 0 and 3 for data communication. In both of these modes, the inputs are latched by the slave device on the rising edge of SCK and outputs are issued on the falling edge. Therefore, the first rising edge of SCK signifies the arrival of the first bit (MSB) of a SPI instruction on the SI pin. Further, all data inputs and outputs are synchronized with SCK.

4.4.5 Data transmission (SI/SO)

The SPI data bus consists of two lines, SI and SO, for serial data communication. SI is also referred to as master out slave in (MOSI) and SO is referred to as master in slave out (MISO). The master issues instructions to the slave through the SI pin, while the slave responds through the SO pin. Multiple slave devices may share the SI and SO lines as described earlier.

The CYRS15B102Q has two separate pins for SI and SO, which can be connected with the master as shown in [Figure 2](#).

For a microcontroller that has no dedicated SPI bus, a general-purpose port may be used. To reduce hardware resources on the controller, it is possible to connect the two data pins (SI and SO) together and tie off (HIGH) the HOLD and WP pins. [Figure 3](#) shows such a configuration, which uses only three pins.

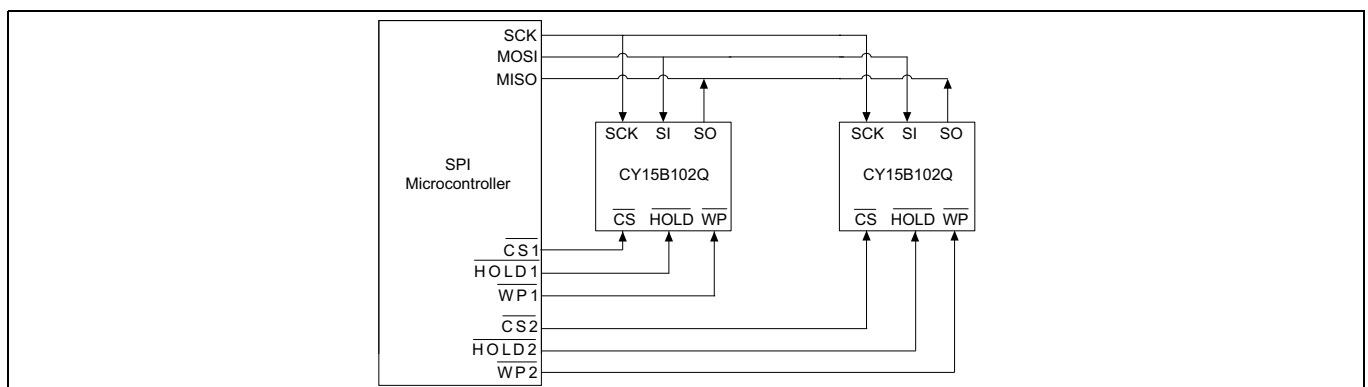

Figure 2 System configuration with SPI port

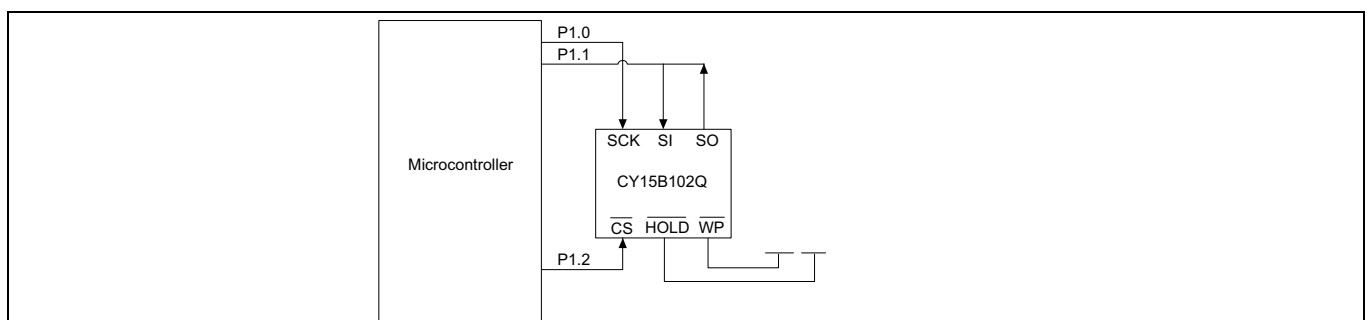

Figure 3 System configuration without SPI port

4.4.6 Most significant bit (MSB)

The SPI protocol requires that the first bit to be transmitted is the most significant bit (MSB). This is valid for both address and data transmission.

The 2-Mbit serial F-RAM requires a 3-byte address for any read or write operation. Because the address is only 18 bits, the first six bits that are fed in are ignored by the device. Although these six bits are ‘don’t care’, Infineon recommends that these bits be set to 0s to enable seamless transition to higher memory densities.

4.4.7 Serial opcode

After the slave device is selected with \overline{CS} going LOW, the first byte received is treated as the opcode for the intended operation. CYRS15B102Q uses the standard opcodes for memory accesses.

4.4.8 Invalid opcode

If an invalid opcode is received, the opcode is ignored and the device ignores any additional serial data on the SI pin until the next falling edge of \overline{CS} , and the SO pin remains tristated.

4.4.9 Status register

CYRS15B102Q has an 8-bit status register. The bits in the status register are used to configure the device. These bits are described in [Table 5 on page 13](#).

4.5 SPI modes

CYRS15B102Q may be driven by a microcontroller with its SPI peripheral running in either of the following two modes:

- SPI mode 0 (CPOL = 0, CPHA = 0)
- SPI mode 3 (CPOL = 1, CPHA = 1)

For both these modes, the input data is latched in on the rising edge of SCK starting from the first rising edge after \overline{CS} goes active. If the clock starts from a HIGH state (in mode 3), the first rising edge after the clock toggles is considered. The output data is available on the falling edge of SCK. The two SPI modes are shown in [Figure 4](#) and [Figure 5 on page 11](#).

The status of the clock when the bus master is not transferring data is:

- SCK remains at 0 for mode 0
- SCK remains at 1 for mode 3

The device detects the SPI mode from the status of the SCK pin when the device is selected by bringing the \overline{CS} pin LOW. If the SCK pin is LOW when the device is selected, SPI mode 0 is assumed and if the SCK pin is HIGH, it works in SPI mode 3.

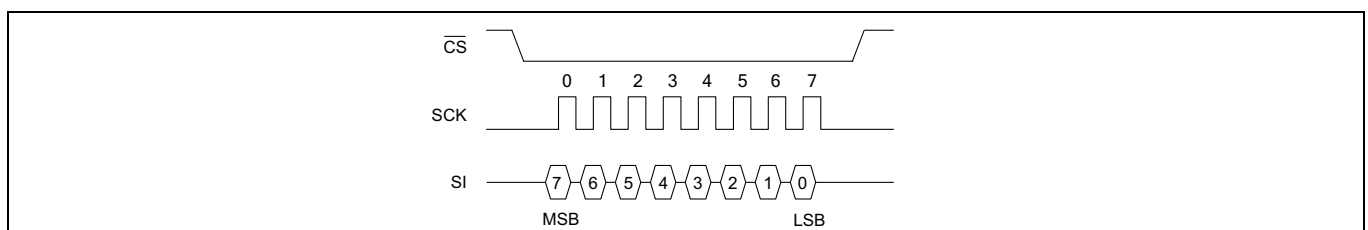

Figure 4 SPI mode 0

Functional overview

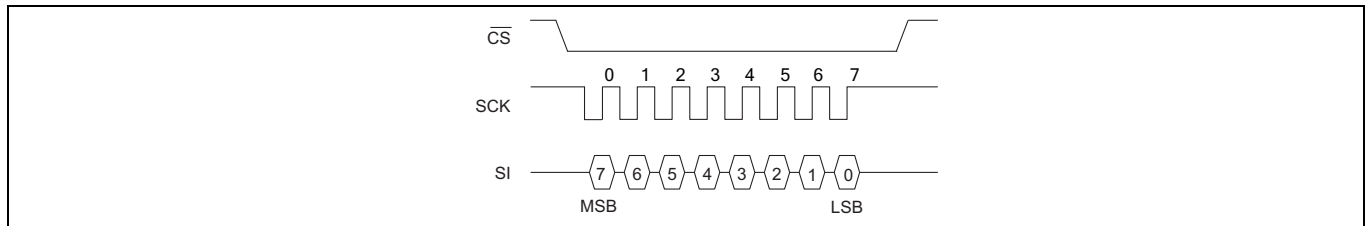

Figure 5 SPI mode 3

4.6 Power up to first access

The CYRS15B102Q is not accessible for a t_{PU} time after power-up. Users must comply with the timing parameter t_{PU} , which is the minimum time from V_{DD} (min) to the first \overline{CS} LOW.

Functional description

5 Functional description

5.1 Command structure

Nine commands, called opcodes, can be issued by the bus master to the CYRS15B102Q. They are listed in [Table 3](#). These opcodes control the functions performed by the memory.

Table 3 Opcode Commands

Name	Description	Opcode
Write enable control		
WREN	Set write enable latch	0000 0110b
WRDI	Reset write enable latch	0000 0100b
Register access		
RDSR	Read status register	0000 0101b
WRSR	Write status register	0000 0001b
Memory write		
WRITE	Write memory data	0000 0010b
Memory read		
READ	Read memory data	0000 0011b
FSTRD	Fast read memory data	0000 1011b
Low power modes		
SLEEP	Enter sleep mode	1011 1001b
Identification and serial number		
RDID	Read device ID	1001 1111b

5.1.1 Write enable control commands

WREN - Set write enable latch

The CYRS15B102Q will power up with writes disabled. The WREN command must be issued before any write operation. Sending the WREN opcode allows the user to issue subsequent opcodes for write operations. These include writing the status register (WRSR) and writing the memory (WRITE).

Sending the WREN opcode causes the internal write enable latch to be set. A flag bit in the status register, called WEL, indicates the state of the latch. WEL = '1' indicates that writes are permitted. Attempting to write the WEL bit in the status register has no effect on the state of this bit - only the WREN opcode can set this bit. The WEL bit will be automatically cleared on the rising edge of \overline{CS} following a WRDI, a WRSR, or a WRITE operation. This prevents further writes to the status register or the F-RAM array without another WREN command. [Figure 6](#) illustrates the WREN command bus configuration.

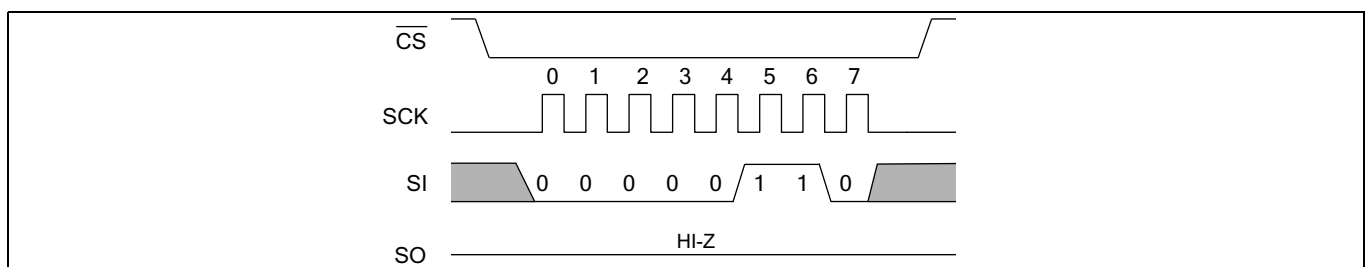

Figure 6 WREN bus configuration

Functional description

WRDI - Reset write enable latch

The WRDI command disables all write activity by clearing the write enable latch. The user can verify that writes are disabled by reading the WEL bit in the status register and verifying that WEL is equal to '0'. [Figure 7](#) illustrates the WRDI command bus configuration.

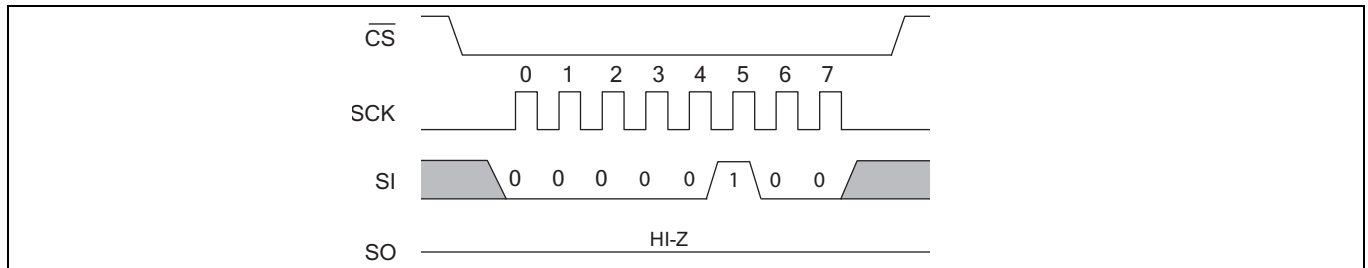

Figure 7 WRDI bus configuration

5.1.2 Register access commands

Status register and write protection

The write protection features of the CYRS15B102Q are multi-tiered and are enabled through the status register. The status register is organized as follows. (The default value shipped from the factory for bit 0, WEL, BP0, BP1, bits 4–5, WPEN is '0', and for bit 6 is '1'.)

Table 4 Status register

Bit 7	Bit 6	Bit 5	Bit 4	Bit 3	Bit 2	Bit 1	Bit 0
WPEN (0)	X (1)	X (0)	X (0)	BP1 (0)	BP0 (0)	WEL (0)	X (0)

Table 5 Status register bit definition

Bit	Definition	Description
Bit 0	Don't care	This bit is non-writable and always returns '0' upon read.
Bit 1 (WEL)	Write enable	WEL indicates if the device is write enabled. This bit defaults to '0' (disabled) on power-up. WEL = '1' --> write enabled WEL = '0' --> write disabled
Bit 2 (BP0)	Block protect bit '0'	Used for block protection. For details, see Table 6 .
Bit 3 (BP1)	Block protect bit '1'	Used for block protection. For details, see Table 6 .
Bit 4–5	Don't care	These bits are non-writable and always return '0' upon read.
Bit 6	Don't care	This bit is non-writable and always returns '1' upon read.
Bit 7 (WPEN)	Write protect enable bit	Used to enable the function of write protect pin (\overline{WP}). For details, see Table 7 .

Functional description

Bits 0 and 4–5 are fixed at ‘0’ and bit 6 is fixed at ‘1’; none of these bits can be modified. Note that bit 0 (“Ready or Write in progress” bit in serial flash and EEPROM) is unnecessary, as the F-RAM writes in real-time and is never busy, so it reads out as a ‘0’. An exception to this is when the device is waking up from sleep mode, which is described in [Sleep mode on page 17](#). The BP1 and BP0 control the software write-protection features and are nonvolatile bits. The WEL flag indicates the state of the write enable latch. Attempting to directly write the WEL bit in the status register has no effect on its state. This bit is internally set and cleared via the WREN and WRDI commands, respectively.

BP1 and BP0 are memory block write protection bits. They specify portions of memory that are write-protected as shown in [Table 6](#).

Table 6 Block memory write protection

BP1	BP0	Protected address range
0	0	None
0	1	30000h to 3FFFFh (upper 1/4)
1	0	20000h to 3FFFFh (upper 1/2)
1	1	00000h to 3FFFFh (all)

The BP1 and BP0 bits and the write enable latch are the only mechanisms that protect the memory from writes. The remaining write protection features protect inadvertent changes to the block protect bits.

The write protect enable bit (WPEN) in the status register controls the effect of the hardware write protect (\overline{WP}) pin. When the WPEN bit is set to ‘0’, the status of the \overline{WP} pin is ignored. When the WPEN bit is set to ‘1’, a LOW on the \overline{WP} pin inhibits a write to the status register. Thus the status register is write-protected only when WPEN = ‘1’ and \overline{WP} = ‘0’.

[Table 7](#) summarizes the write protection conditions.

Table 7 Write protection

WEL	WPEN	\overline{WP}	Protected blocks	Unprotected blocks	Status register
0	X	X	Protected	Protected	Protected
1	0	X	Protected	Unprotected	Unprotected
1	1	0	Protected	Unprotected	Protected
1	1	1	Protected	Unprotected	Unprotected

RDSR - Read status register

The RDSR command allows the bus master to verify the contents of the status register. Reading the status register provides information about the current state of the write-protection features. Following the RDSR opcode, the CYRS15B102Q will return one byte with the contents of the status register.

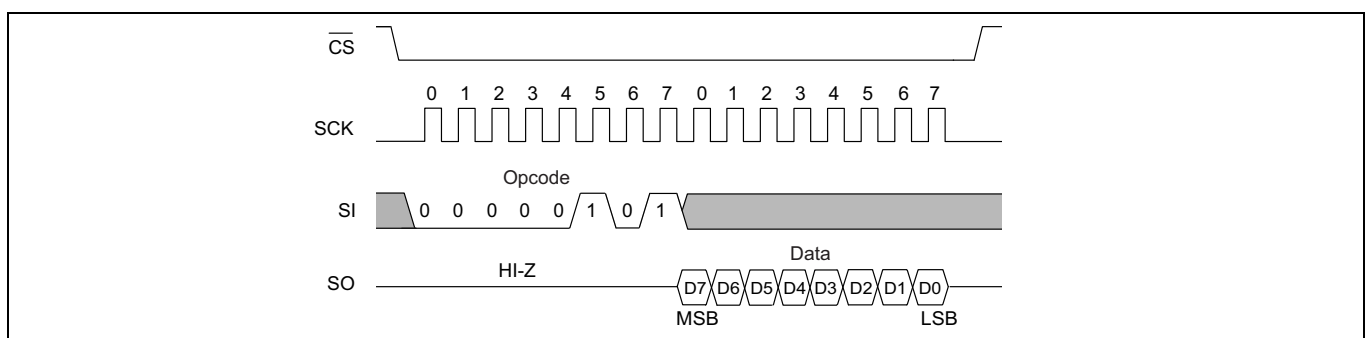

Figure 8 RDSR bus configuration

Functional description

WRSR - Write status register

The WRSR command allows the SPI bus master to write into the status register and change the write protect configuration by setting the WPEN, BP0, and BP1 bits as required. Before issuing a WRSR command, the WP pin must be HIGH or inactive. Note that on the CYRS15B102Q, WP only prevents writing to the status register, not the memory array. Before sending the WRSR command, the user must send a WREN command to enable writes. Executing a WRSR command is a write operation and therefore, clears the write enable latch.

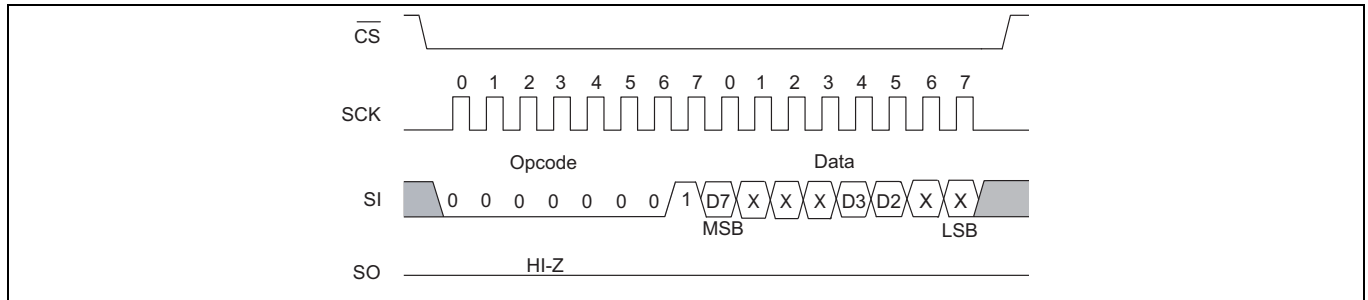

Figure 9 WRSR bus configuration (WREN not shown)

5.1.3 Memory operation commands

The SPI interface, which is capable of a high clock frequency, highlights the fast write capability of the F-RAM technology. Unlike serial flash and EEPROMs, CYRS15B102Q can perform sequential writes at bus speed. No page register is needed and any number of sequential writes may be performed.

5.1.4 Memory write operation commands

All writes to the memory begin with a WREN opcode with CS being asserted and deasserted. The next opcode is WRITE. The WRITE opcode is followed by a three-byte address containing the 18-bit address (A17–A0) of the first data byte to be written into the memory. The upper six bits of the three-byte address are ignored. Subsequent bytes are data bytes, which are written sequentially. Addresses are incremented internally as long as the bus master continues to issue clocks and keeps CS LOW. If the last address of 3FFFFh is reached, the counter will roll over to 00000h. Data is written to MSB first. The rising edge of CS terminates a write operation. A write operation is shown in **Figure 10**.

Note When a burst write reaches a protected block address, the automatic address increment stops and all the subsequent data bytes received for write will be ignored by the device.

EEPROMs use page buffers to increase their write throughput. This compensates for the technology’s inherently slow write operations. F-RAM memories do not have page buffers because each byte is written to the F-RAM array immediately after it is clocked in (after the eighth clock). This allows any number of bytes to be written without page buffer delays.

Note If the power is lost in the middle of the write operation, only the last completed byte will be written.

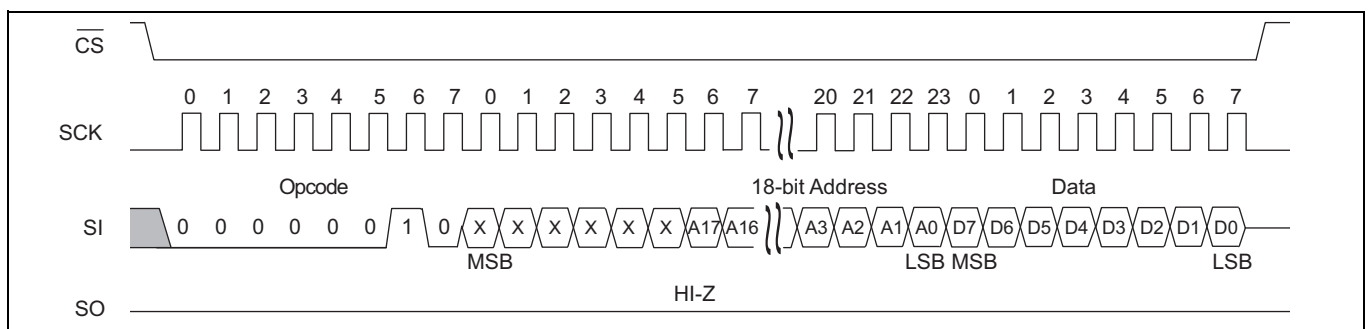

Figure 10 Memory write (WREN not shown) operation

Functional description

5.1.5 Memory read operation commands

Read operation

After the falling edge of \overline{CS} , the bus master can issue a READ opcode. Following the READ command is a three-byte address containing the 18-bit address (A17–A0) of the first byte of the read operation. The upper six bits of the address are ignored. After the opcode and address are issued, the device drives out the read data on the next eight clocks. The SI input is ignored during read data bytes. Subsequent bytes are data bytes, which are read out sequentially. Addresses are incremented internally as long as the bus master continues to issue clocks and \overline{CS} is LOW. If the last address of 3FFFFh is reached, the counter will roll over to 00000h. Data is read MSB first. The rising edge of CS terminates a read operation and tristates the SO pin. A read operation is shown in **Figure 11**.

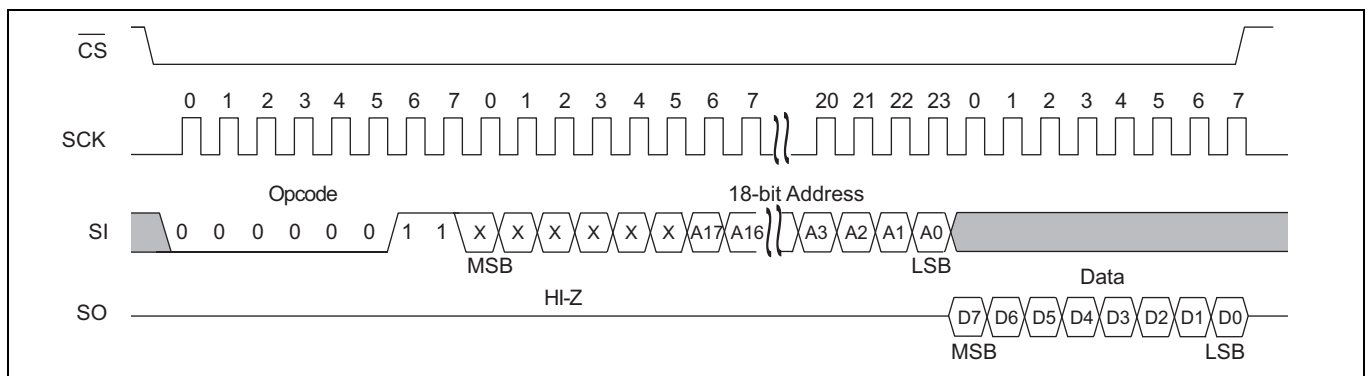

Figure 11 Memory read operation

Fast read operation

The CYRS15B102Q supports a FAST READ opcode (0Bh) that is provided for code compatibility with serial flash devices. The FAST READ opcode is followed by a three-byte address containing the 18-bit address (A17–A0) of the first byte of the read operation and then a dummy byte. The dummy byte inserts a read latency of the eight-clock cycle. The fast read operation is otherwise the same as an ordinary read operation except that it requires an additional dummy byte. After receiving the opcode, address, and a dummy byte, the CYRS15B102Q starts driving its SO line with data bytes, with MSB first, and continues transmitting as long as the device is selected and the clock is available. In case of bulk read, the internal address counter is incremented automatically, and after the last address 3FFFFh is reached, the counter rolls over to 00000h. When the device is driving data on its SO line, any transition on its SI line is ignored. The rising edge of \overline{CS} terminates a fast read operation and tristates the SO pin. A fast read operation is shown in **Figure 12**.

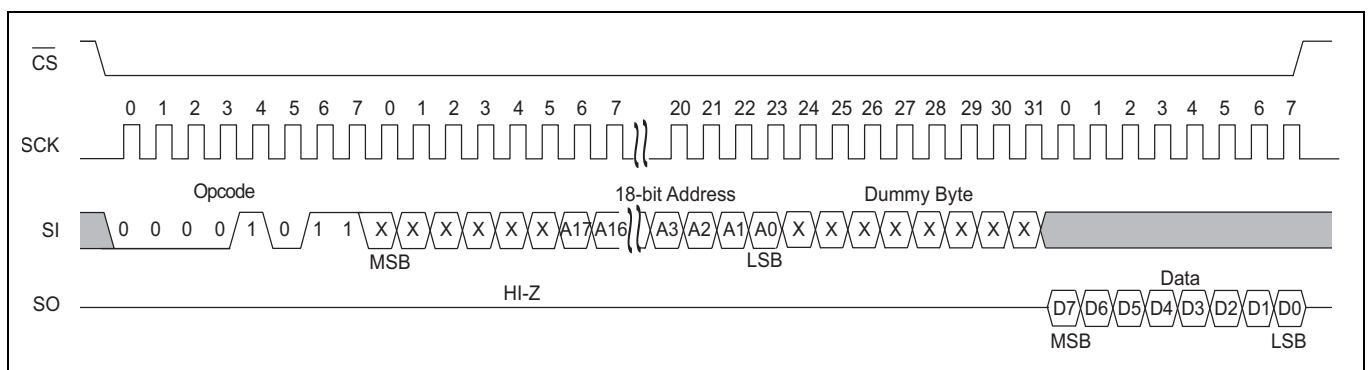

Figure 12 Fast read operation

Functional description

5.1.6 Interrupt operation commands

HOLD pin operation

The $\overline{\text{HOLD}}$ pin can be used to interrupt a serial operation without aborting it. If the bus master pulls the $\overline{\text{HOLD}}$ pin LOW while SCK is LOW, the current operation will pause. Taking the $\overline{\text{HOLD}}$ pin HIGH while SCK is LOW will resume an operation. The transitions of $\overline{\text{HOLD}}$ must occur while SCK is LOW, but the SCK and $\overline{\text{CS}}$ pin can toggle during a hold state.

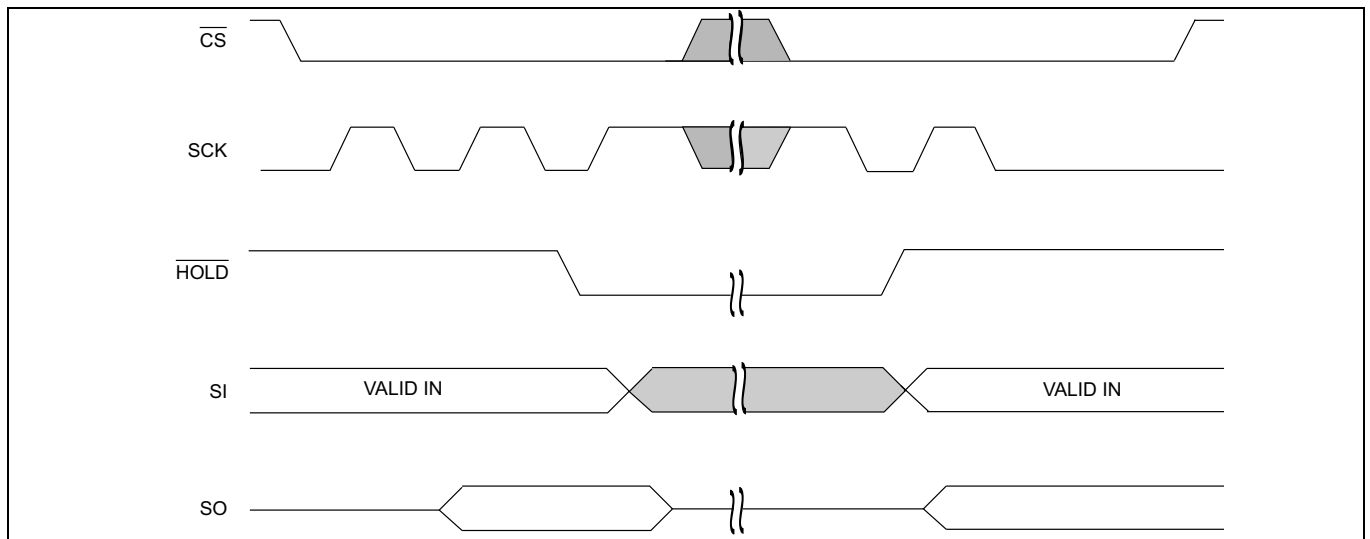

Figure 13 $\overline{\text{HOLD}}$ operation [2]

5.1.7 Low power mode commands

Sleep mode

A low-power sleep mode is implemented on the CYRS15B102Q device. The device will enter the low-power state when the SLEEP opcode B9h is clocked-in and a rising edge of $\overline{\text{CS}}$ is applied. When in sleep mode, the SCK and SI pins are ignored and SO will be HI-Z, but the device continues to monitor the $\overline{\text{CS}}$ pin. On the next falling edge of $\overline{\text{CS}}$, the device will return to normal operation within t_{REC} time. The SO pin remains in a HI-Z state during the wakeup period. The device does not necessarily respond to an opcode within the wakeup period. To start the wakeup procedure, the controller may send a “dummy” read, for example, and wait the remaining t_{REC} time. Please note that the sleep current deteriorates with increasing TID exposure and can reach up to 8 mA at full TID exposure of 150Krad at 50rad(Si)/s exposure rate.

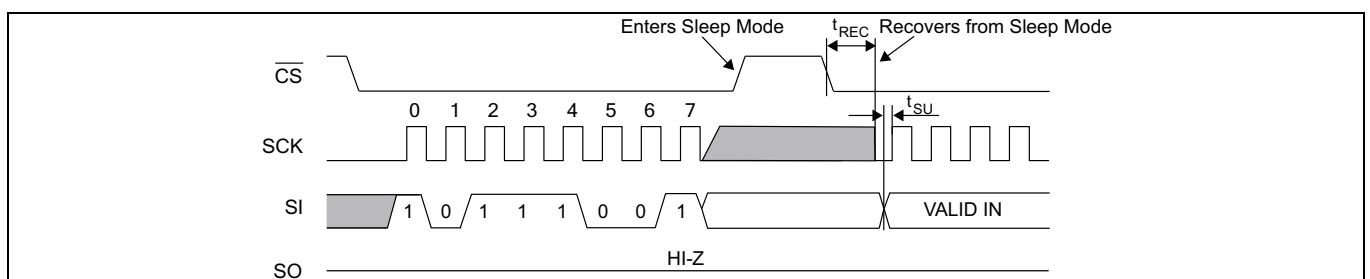

Figure 14 Sleep mode operation

Note

2. Figure 13 shows the $\overline{\text{HOLD}}$ operation for input mode and output mode.

5.1.8 Identification and serial number commands

Device ID

The CYRS15B102Q device can be interrogated for its manufacturer, product identification, and die revision. The RDID opcode 9Fh allows the user to read the manufacturer ID and product ID, both of which are read-only bytes. The JEDEC-assigned manufacturer ID places the Infineon (Ramtron) identifier in bank 7; therefore, there are six bytes of the continuation code 7Fh followed by the single byte C2h. There are two bytes of product ID, which includes a family code, a density code, a sub code, and the product revision code.

Table 8 Device ID

Device ID (9 bytes)	Device ID description					
	71-16 (56 bits)	15-13 (3 bits)	12-8 (5 bits)	7-6 (2 bits)	5-3 (3 bits)	2-0 (3 bits)
	Manufacturer ID	Product ID				
Family		Density	Sub	Rev	Rsvd	
7F7F7F7F7F7FC225C8h	011111110111111101111111 101111111011111110111111 1111000010	001	00101	11	001	000

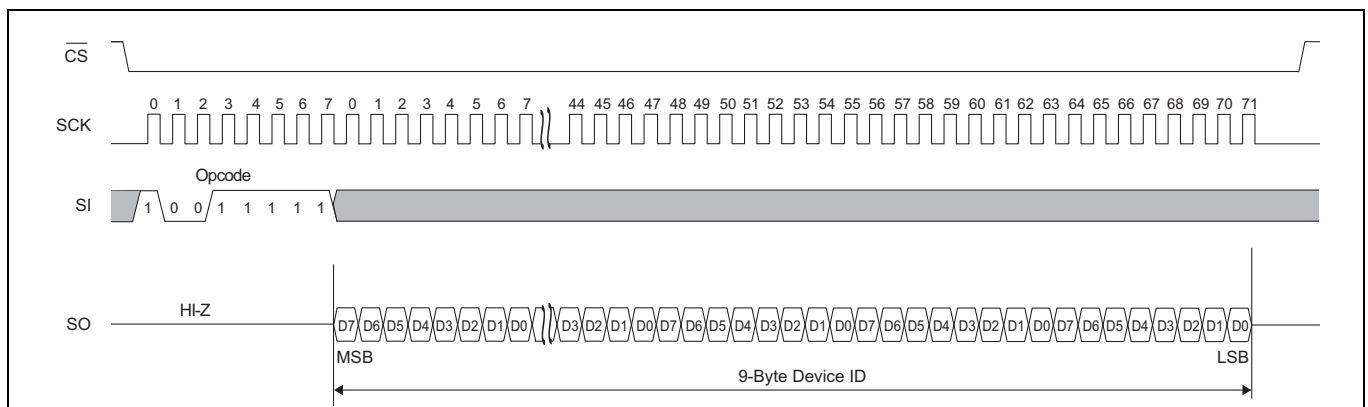

Figure 15 Read device ID

5.2 Endurance

The CYRS15B102Q devices are capable of being accessed at least 10^{13} times, reads or writes. An F-RAM memory operates with a read and restore mechanism. Therefore, an endurance cycle is applied on a row basis for each access (read or write) to the memory array. The F-RAM architecture is based on an array of rows and columns of 32K rows of 64-bits each. The entire row is internally accessed once whether a single byte or all eight bytes are read or written. Each byte in the row is counted only once in an endurance calculation. [Table 9](#) shows endurance calculations for a 64-byte repeating loop, which includes an opcode, a starting address, and a sequential 64-byte data stream. This causes each byte to experience one endurance cycle through the loop.

Table 9 Time to reach endurance limit for repeating 64-byte loop

SCK freq (MHz)	Endurance cycles/sec	Endurance cycles/year	Years to reach limit
25	45,950	1.45×10^{12}	6.91
10	18,380	5.79×10^{11}	17.27
5	9,190	2.90×10^{11}	34.5

5.3 Qualification and screening

The 130-nm radiation-tolerant FRAM technology was qualified by Infineon after meeting the criteria of the general manufacturing standards. The test flow includes screening units with the defined flow (Class V) and the appropriate periodic or lot conformance testing (Groups A, B, C, D, and E). Both the 130-nm process and the FRAM products are subject to period or lot-based technology conformance inspection (TCI) and quality conformance inspection (QCI) tests, respectively. Infineon offers both prototyping models and flight units of these product configurations.

Table 10 Qualification tests

Group	Tests
Group A	General electrical tests
Group B	Mechanical - Dimensions, bond strength, solvents, die shear, solderability, lead Integrity, seal, and acceleration
Group C	Life tests - 1000 hours at 125 °C or equivalent
Group D	Package related mechanical tests - shock, vibration, acceleration, salt, seal, lead finish adhesion, lid torque, thermal shock, and moisture resistance
Group E	Radiation tests

5.4 Single event functional interrupt elimination

As outlined in the product feature section, the intrinsic single event functional interrupt (SEFI) rate of the CYRS15B102Q device is 1.34×10^{-4} upsets/device-day, which equates to a SEFI event failure every 20 years at GEO orbit (solar min). To eliminate SEFI events, Infineon recommends entering the low-power sleep mode (as described in [Figure 14 on page 17](#)) followed by an immediate exit out of the sleep mode before any read/write operation on the device. The entry/exit of the deep sleep mode will reset and initialize all execution/configuration registers and ensure correct addressing and configuration of the device. This procedure is recommended before the first read/write operation of consecutive operations. The SPI controller/processor may insert a “dummy” read, for example, and wait the remaining t_{REC} time prior to every block read/write operation.

Alternatively, the device can also be power cycled prior of the first read and after a prolonged radiation exposure. Power cycling and sleep-wakeup sequencing are equally effective to eliminate SEFI events. Details can be obtained from the SEE radiation report.

6 Electrical characteristics

6.1 Maximum ratings

Exceeding maximum ratings may shorten the useful life of the device. These user guidelines are not tested.

Storage temperature	-65 °C to +150 °C
Maximum accumulated storage time	
At 150 °C ambient temperature	1000 h
At 125 °C ambient temperature	11000 h
At 85 °C ambient temperature	121 Years
Case temperature	
with power applied	-55 °C to +125 °C
Supply voltage on V_{DD} relative to V_{SS}	-1.0 V to + 4.5 V
Input voltage	-1.0 V to +4.5 V and $V_{IN} < V_{DD} + 1.0$ V
DC voltage applied to outputs	
in High-Z state	-0.5 V to $V_{DD} + 0.5$ V
Transient voltage (< 20 ns)	
on any pin to ground potential ...	-2.0 V to $V_{DD} + 2.0$ V
Package power dissipation capability	
($T_A = 25$ °C)	1.0 W
Surface mount lead soldering temperature	
(3 seconds)	+ 260 °C
DC output current	
(1 output at a time, 1s duration)	15 mA
Electrostatic discharge voltage	
Human body model (JEDEC Std JESD22-A114-B)	2 kV
Charged device model (JEDEC Std JESD22-C101-A)	500 V
Latch-up current	> 140 mA

6.2 Operating range

Table 11 Operating range

Range	Ambient temperature (T_A)	V_{DD}
Military	-55 °C to +125 °C	2.0 V to 3.6 V

Electrical characteristics

6.3 DC electrical characteristics

Table 12 DC electrical characteristics

Over the **Operating range**

Parameter	Description	Test Conditions	Min	Typ ^[3]	Max	Unit	
V _{DD}	Power supply		2.0	3.3	3.6	V	
I _{DD}	V _{DD} supply current	f _{SCK} = 25 MHz; SCK toggling between V _{DD} - 0.2 V and V _{SS} , other inputs V _{SS} or V _{DD} - 0.2 V. SO = Open	-	-	10	mA	
I _{SB}	V _{DD} standby current	CS = V _{DD} . All other inputs V _{SS} or V _{DD}	TID = 0Krad	-	100	850	μA
			TID = 150Krad	-	-	6	mA
I _{ZZ}	Sleep mode current	CS = V _{DD} . All other inputs V _{SS} or V _{DD}	TID = 0Krad	-	3	25	μA
			TID = 150Krad	-	-	8	mA
I _{LI}	Input leakage current	V _{SS} ≤ V _{IN} ≤ V _{DD}	-	-	±10	μA	
I _{LO}	Output leakage current	V _{SS} ≤ V _{OUT} ≤ V _{DD}	-	-	±10	μA	
V _{IH}	Input HIGH voltage		0.7 × V _{DD}	-	V _{DD} + 0.3	V	
V _{IL}	Input LOW voltage		-0.3	-	0.3 × V _{DD}	V	
V _{OH1}	Output HIGH voltage	I _{OH} = -1 mA, V _{DD} = 2.7 V	2.4	-	-	V	
V _{OH2}	Output HIGH voltage	I _{OH} = -100 μA	V _{DD} - 0.2	-	-	V	
V _{OL1}	Output LOW voltage	I _{OL} = 2 mA, V _{DD} = 2.7 V	-	-	0.4	V	
V _{OL2}	Output LOW voltage	I _{OL} = 150 μA	-	-	0.2	V	

Note3. Typical values are at 25 °C, V_{DD} = V_{DD} (typ). Not 100% tested.

6.4 Data retention and endurance

Table 13 Data retention and endurance

Parameter	Description	Test condition	Min	Max	Unit
T_{DR}	Data retention	$T_A = 125\text{ °C}$	11000	–	hours
		$T_A = 105\text{ °C}$	11	–	years
		$T_A = 85\text{ °C}$	121	–	years
NV_C	Endurance	Over operating temperature	10^{13}	–	cycles

6.5 Capacitance

Table 14 Capacitance

Parameter ^[4]	Description	Test conditions	Max	Unit
C_O	Output pin capacitance (SO)	$T_A = 25\text{ °C}$, $f = 1\text{ MHz}$, $V_{DD} = V_{DD}(\text{typ})$	8	pF
C_I	Input pin capacitance		6	pF

6.6 Thermal resistance

Table 15 Thermal resistance

Parameter ^[4]	Description	Test conditions	16-pin ceramic SOP	Unit
Θ_{JC}	Thermal resistance (junction to case)	Test according to MIL-PRF 38538	17.04	°C/W

6.7 AC test conditions

Input pulse levels 10% and 90% of V_{DD}

Input rise and fall times 3 ns

Input and output timing reference levels $0.5 \times V_{DD}$

Output load capacitance 30 pF

Note

4. This parameter is periodically sampled and not 100% tested.

6.8 AC switching characteristics

Table 16 AC switching characteristics

Over the **Operating range**

Parameters ^[5]		Description	$V_{DD} = 2.0V \text{ to } 3.6V$		Unit
Infineon parameter	Alt. parameter		Min	Max	
f_{SCK}	–	SCK clock frequency	0	25	MHz
t_{CH}	–	Clock HIGH time	18	–	ns
t_{CL}	–	Clock LOW time	18	–	ns
t_{CSU}	t_{CSS}	Chip select setup	12	–	ns
t_{CSH}	t_{CSH}	Chip select hold	12	–	ns
$t_{OD}^{[6,7]}$	t_{HZCS}	Output disable time	–	20	ns
t_{ODV}	t_{CO}	Output data valid time	–	16	ns
t_{OH}	–	Output hold time	0	–	ns
t_D	–	Deselect time	60	–	ns
$t_R^{[8,9]}$	–	Data in rise time	–	50	ns
$t_F^{[8,9]}$	–	Data in fall time	–	50	ns
t_{SU}	t_{SD}	Data setup time	8	–	ns
t_H	t_{HD}	Data hold time	8	–	ns
t_{HS}	t_{SH}	$\overline{\text{HOLD}}$ setup time	12	–	ns
t_{HH}	t_{HH}	$\overline{\text{HOLD}}$ hold time	12	–	ns
$t_{HZ}^{[6,7]}$	t_{HHZ}	$\overline{\text{HOLD}}$ LOW to HI-Z	–	25	ns
$t_{LZ}^{[7]}$	t_{HLZ}	$\overline{\text{HOLD}}$ HIGH to data active	–	25	ns

Notes

5. Test conditions assume a signal transition time of 3 ns or less, timing reference levels of $0.5 \times V_{DD}$, input pulse levels of 10% to 90% of V_{DD} , output loading of the specified I_{OL}/I_{OH} and 30-pF load capacitance shown in **AC test conditions on page 22**.
6. t_{OD} and t_{HZ} are specified with a load capacitance of 5 pF. Transition is measured when the outputs enter a high impedance state.
7. Characterized but not 100% tested in production.
8. Rise and fall times measured between 10% and 90% of waveform.
9. These parameters are guaranteed by design and are not tested.

Electrical characteristics

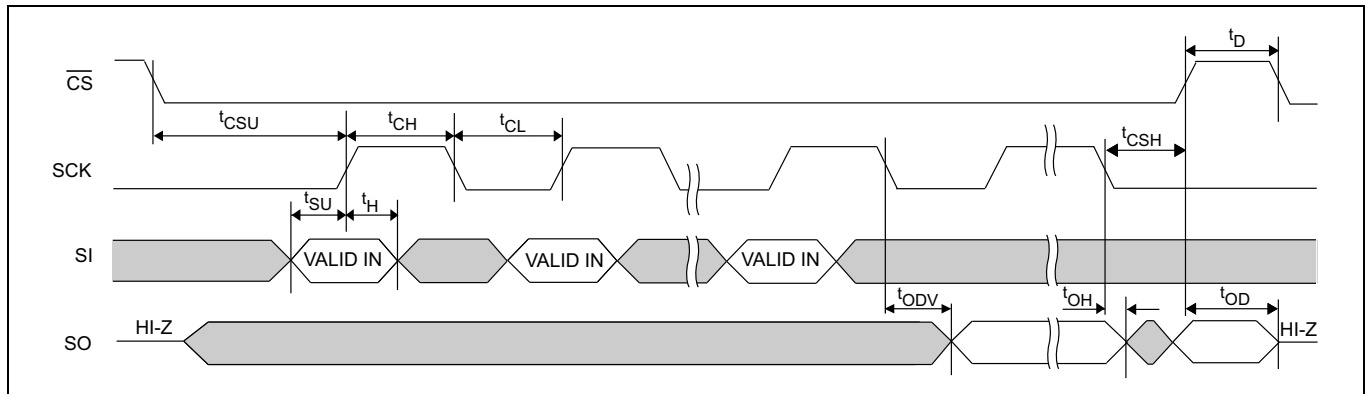

Figure 16 Synchronous data timing (mode 0)

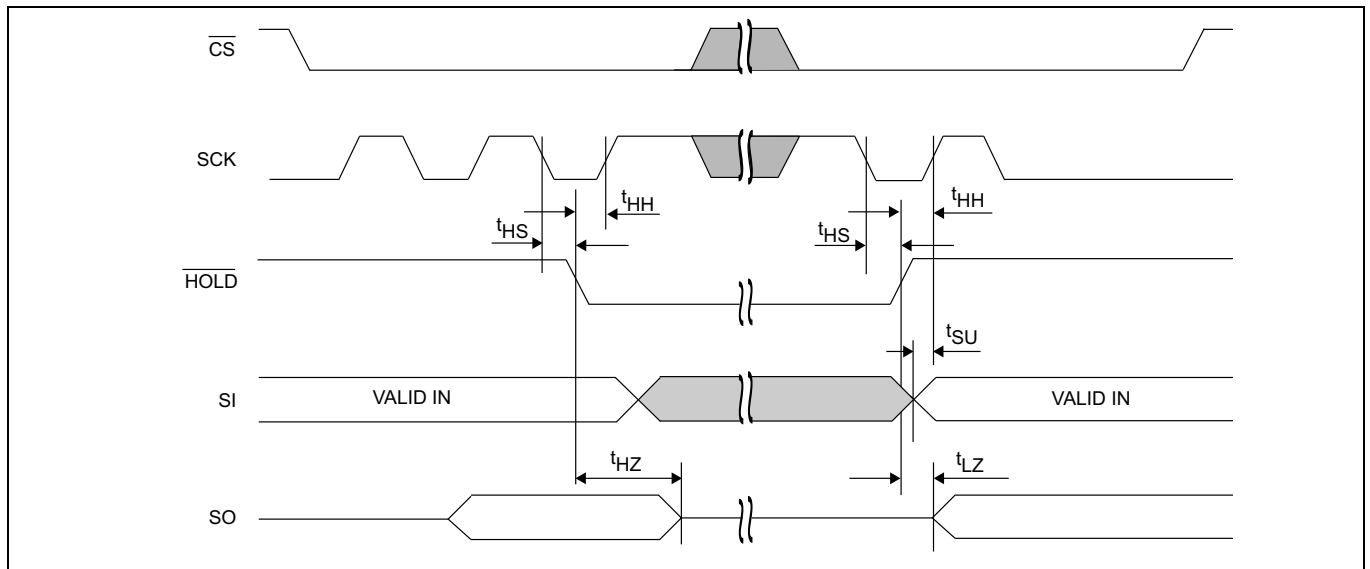

Figure 17 \overline{HOLD} timing

6.9 Power cycle timing

Table 17 Power cycle timing

Over the **Operating range**

Parameter	Description	Min	Max	Unit
t_{PU}	Power-up $V_{DD}(\text{min})$ to first access (\overline{CS} LOW)	1	–	ms
t_{PD}	Last access (\overline{CS} HIGH) to power-down ($V_{DD}(\text{min})$)	0	–	μs
$t_{VR}^{[10]}$	V_{DD} power-up ramp rate	50	–	$\mu\text{s}/\text{V}$
$t_{VF}^{[10]}$	V_{DD} power-down ramp rate	100	–	$\mu\text{s}/\text{V}$
$t_{REC}^{[11]}$	Recovery time from Sleep mode	–	450	μs

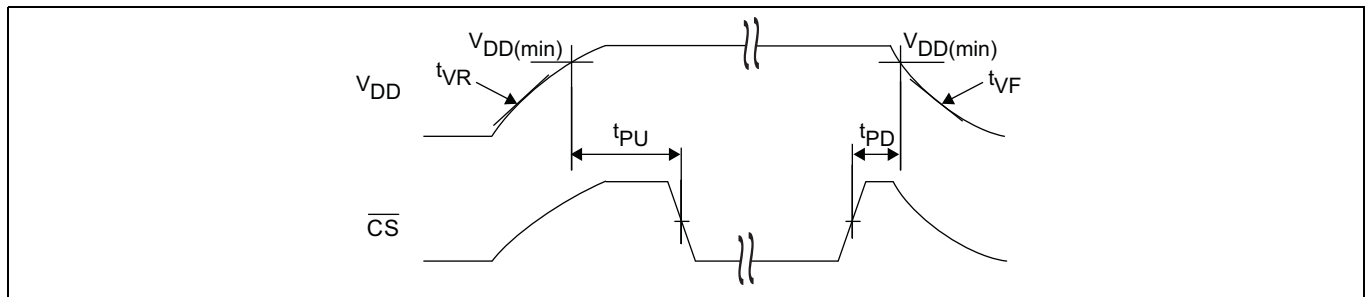

Figure 18 Power cycle timing

Notes

10. Slope measured at any point on V_{DD} waveform.

11. Guaranteed by design. Refer to **Figure 14 on page 17** for sleep mode recovery timing.

Ordering information

7 Ordering information

Table 18 Ordering information

Ordering code	Package diagram	Package type	Operating range
CYRS15B102Q-GGMB	002-23171	16-pin ceramic SOP package	Military
CYPT15B102Q-GGMB	002-23171	16-pin ceramic SOP package, Prototype unit	Military
5962R1821601VXC	002-23171	16-pin ceramic SOP package, QML-V DLAM certified unit	Military

These parts are Pb-free. Contact your local Infineon sales representative for availability of these parts.

7.1 Ordering code definitions

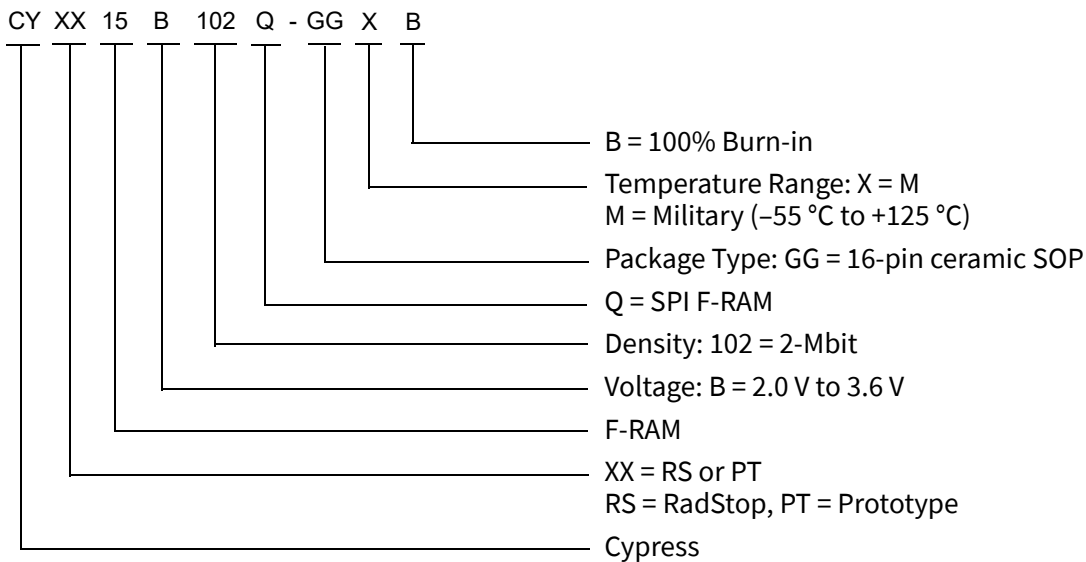

5962R-18216 01 V X C

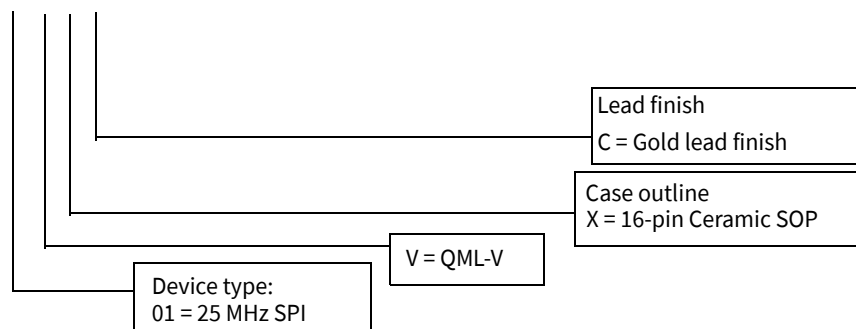

8 Package diagrams

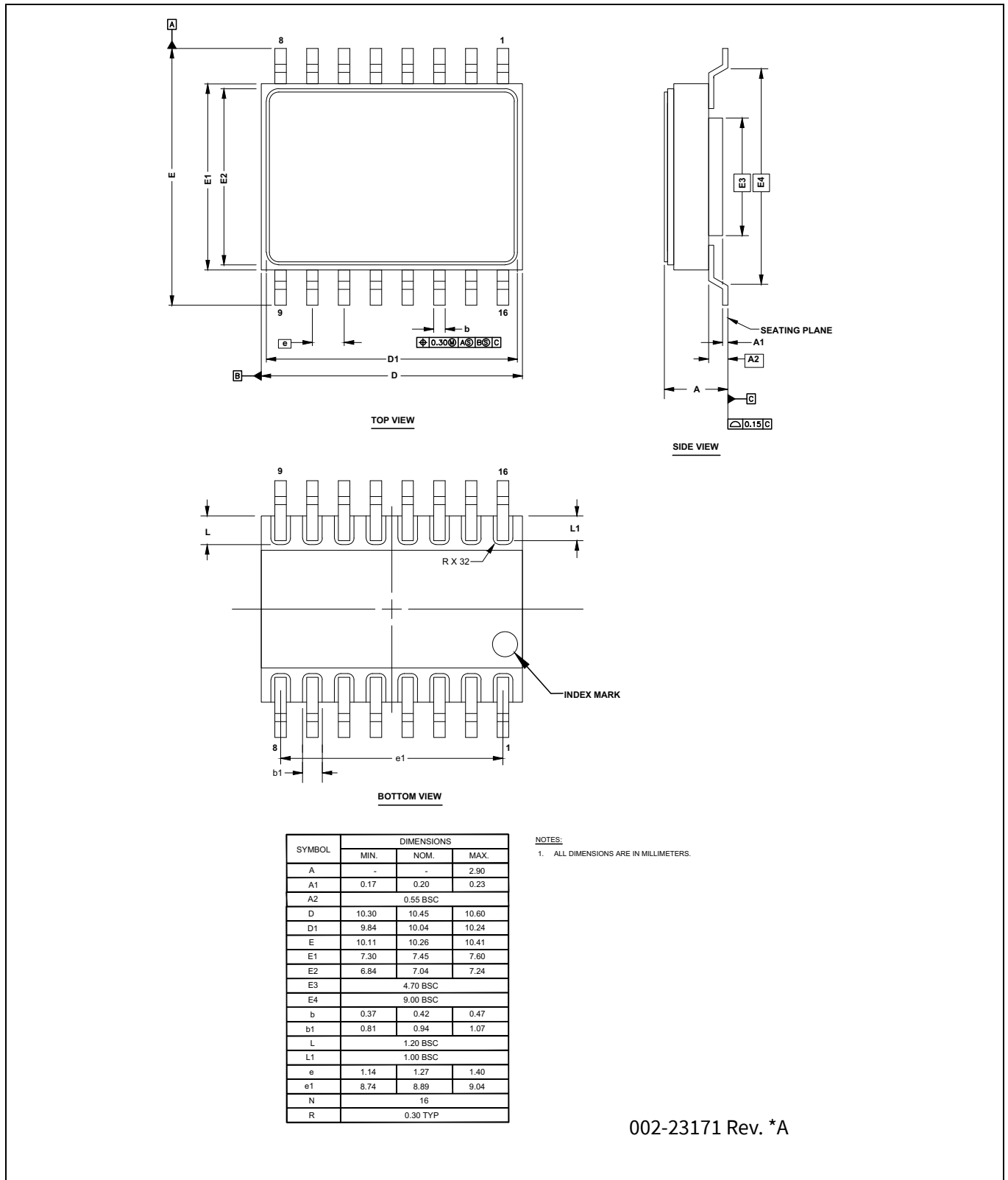

Figure 19 16-pin CSOP (10.45 × 7.45 × 2.90 mm) package outline, 002-23171

9 Acronyms

Table 19 Acronyms

Acronym	Description
CPHA	Clock Phase
CPOL	Clock Polarity
EEPROM	Electrically Erasable Programmable Read-Only Memory
EIA	Electronic Industries Alliance
F-RAM	Ferroelectric Random Access Memory
I/O	Input/Output
JEDEC	Joint Electron Devices Engineering Council
JESD	JEDEC Standards
LSB	Least Significant Bit
MSB	Most Significant Bit
RoHS	Restriction of Hazardous Substances
SPI	Serial Peripheral Interface
SOIC	Small Outline Integrated Circuit

10 Document conventions

10.1 Units of measure

Table 20 Units of measure

Symbol	Unit of measure
°C	degree Celsius
Hz	hertz
kHz	kilohertz
kΩ	kiloohm
Krad	kilorad
Mbit	megabit
MHz	megahertz
μA	microampere
μF	microfarad
μs	microsecond
mA	milliampere
ms	millisecond
ns	nanosecond
Ω	ohm
%	percent
pF	picofarad
V	volt
W	watt

Revision history

Revision history

Document version	Date of release	Description of changes
**	2017-03-08	New data sheet.
*A	2018-03-06	Updated Ordering information : Updated part numbers. Updated Ordering code definitions . Updated Package diagrams : Removed spec 001-67583 *C. Added spec 002-23171 **. Updated to new template. Completing Sunset Review.
*B	2018-08-06	Updated Ordering information : Updated part numbers. Updated Ordering code definitions .
*C	2018-12-07	Updated Maximum ratings : Replaced “-55 °C to +150 °C” with “-65 °C to +150 °C” in ratings corresponding to “Storage temperature”.
*D	2021-05-27	Updated Ordering information : Updated part numbers. Updated Ordering code definitions . Updated to new template.
*E	2021-12-10	Changed status from Preliminary to Final. Updated document title to read as “CYRS15B102Q, Radiation hardened, 2-Mbit Serial (SPI) F-RAM”. Replaced Cypress with Infineon in required instances across the document. Updated Radiation performance : Updated description. Updated Functional description : Updated Single event functional interrupt elimination : Updated description. Updated Electrical characteristics : Updated DC electrical characteristics : Updated all details corresponding to I_{SB} , I_{ZZ} parameters. Updated Thermal resistance : Replaced TBD with 17.04 in “16-pin ceramic SOP” column corresponding to Θ_{JC} parameter. Updated Package diagrams : spec 002-23171 – Changed revision from ** to *A. Migrated to Infineon template.

Trademarks

All referenced product or service names and trademarks are the property of their respective owners.

Edition 2021-12-10
Published by
Infineon Technologies AG
81726 Munich, Germany

© 2002 Infineon Technologies AG.
All Rights Reserved.

Do you have a question about this document?
Go to www.cypress.com/support

Document reference
002-19045 Rev. *E

IMPORTANT NOTICE

The information given in this document shall in no event be regarded as a guarantee of conditions or characteristics ("Beschaffenhheitsgarantie").

With respect to any examples, hints or any typical values stated herein and/or any information regarding the application of the product, Infineon Technologies hereby disclaims any and all warranties and liabilities of any kind, including without limitation warranties of non-infringement of intellectual property rights of any third party.

In addition, any information given in this document is subject to customer's compliance with its obligations stated in this document and any applicable legal requirements, norms and standards concerning customer's products and any use of the product of Infineon Technologies in customer's applications.

The data contained in this document is exclusively intended for technically trained staff. It is the responsibility of customer's technical departments to evaluate the suitability of the product for the intended application and the completeness of the product information given in this document with respect to such application.

For further information on the product, technology, delivery terms and conditions and prices please contact your nearest Infineon Technologies office (www.infineon.com).

WARNINGS

Due to technical requirements products may contain dangerous substances. For information on the types in question please contact your nearest Infineon Technologies office.

Except as otherwise explicitly approved by Infineon Technologies in a written document signed by authorized representatives of Infineon Technologies, Infineon Technologies' products may not be used in any applications where a failure of the product or any consequences of the use thereof can reasonably be expected to result in personal injury.

X-ON Electronics

Largest Supplier of Electrical and Electronic Components

Click to view similar products for [F-RAM](#) category:

Click to view products by [Infineon](#) manufacturer:

Other Similar products are found below :

[FM22LD16-55-BG](#) [FM25CL64B-DGTR](#) [CY15B104Q-PZXI](#) [CY15B128Q-SXE](#) [CY15B256Q-SXAT](#) [FM25V20A-DGTR](#) [MB85RC64APNF-G-JNE1](#) [MB85RS128BPNF-G-JNE1](#) [MB85RC04VPNF-G-JNE1](#) [MB85R4002ANC-GE1](#) [FM25640B-GTR](#) [FM25V02A-DGQ](#) [FM24V05-GTR](#) [CY15B104Q-LHXIT](#) [CY15B104Q-SXIT](#) [FM24V01A-GTR](#) [FM24V02A-GTR](#) [FM24W256-GTR](#) [FM28V020-SGTR](#) [CY15B104QI-20LPXC](#) [CY15B104Q-LHXI](#) [CY15V108QN-20LPXI](#) [CY15B104QSN-108LPXI](#) [CY15B104QSN-108SXI](#) [CY15B104Q-SXI](#) [CY15B108QI-20LPXC](#) [CY15B108QI-20LPXI](#) [CY15V104QSN-108LPXI](#) [CY15V104QSN-108SXI](#) [CY15V108QI-20LPXC](#) [CY15V108QN-20LPXC](#) [FM16W08-SG](#) [FM1808B-SG](#) [FM18W08-SG](#) [FM22L16-55-TG](#) [FM24C04B-G](#) [FM24C04B-GTR](#) [FM24C16B-GTR](#) [FM24C64B-G](#) [FM24CL04B-G](#) [FM24CL04B-GTR](#) [FM24CL16B-DG](#) [FM24CL16B-GTR](#) [FM24CL64B-G](#) [FM24CL64B-GTR](#) [FM24V05-G](#) [FM24V10-G](#) [FM24VN10-G](#) [FM24W256-G](#) [FM25C160B-GTR](#)