

Quick Start Guide

Smart Battery Switch (SBS) HW Version 3

Product Safety Warnings

- The Smart Battery Switch (SBS) is only intended to be used as an engineering demonstrator. It is not intended for extensive use or to be re-used in a product or system that is sold to consumers.
- The SBS is intended to be used by electrical engineers who are experts in the field of high current design. If you are not qualified, seek the help of an expert before using the demonstrator.
- Questions about the SBS should be directed to Infineon Application Engineering.
- The cable, cable lug, washer and nut used to connect to the bolt mounted onto the SBS demonstrator's circuit board must all be made of high current-capable metals which will not experience a significant temperature rise while conducting the current.
- Battery Camping compliant to IEC 60095-2_Ed.4 (2009)
- The cable lug must be mounted directly to the bolt (torque 6Nm \pm 1Nm).
- Keep the current below 1800 A. The time a current may be applied is limited by the temperature rise.
- Don't exceed 1 Joule of switching energy.
- Switching to high currents or to high switch off energy may destroy the switch and the test setup and end up in fire.

Content

- Schematic
- How to connect the SBS

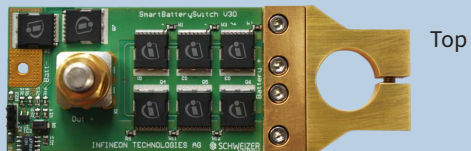

Top

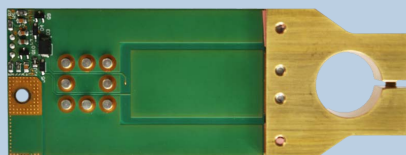

Bottom

Schematic

Battery Positive Terminal

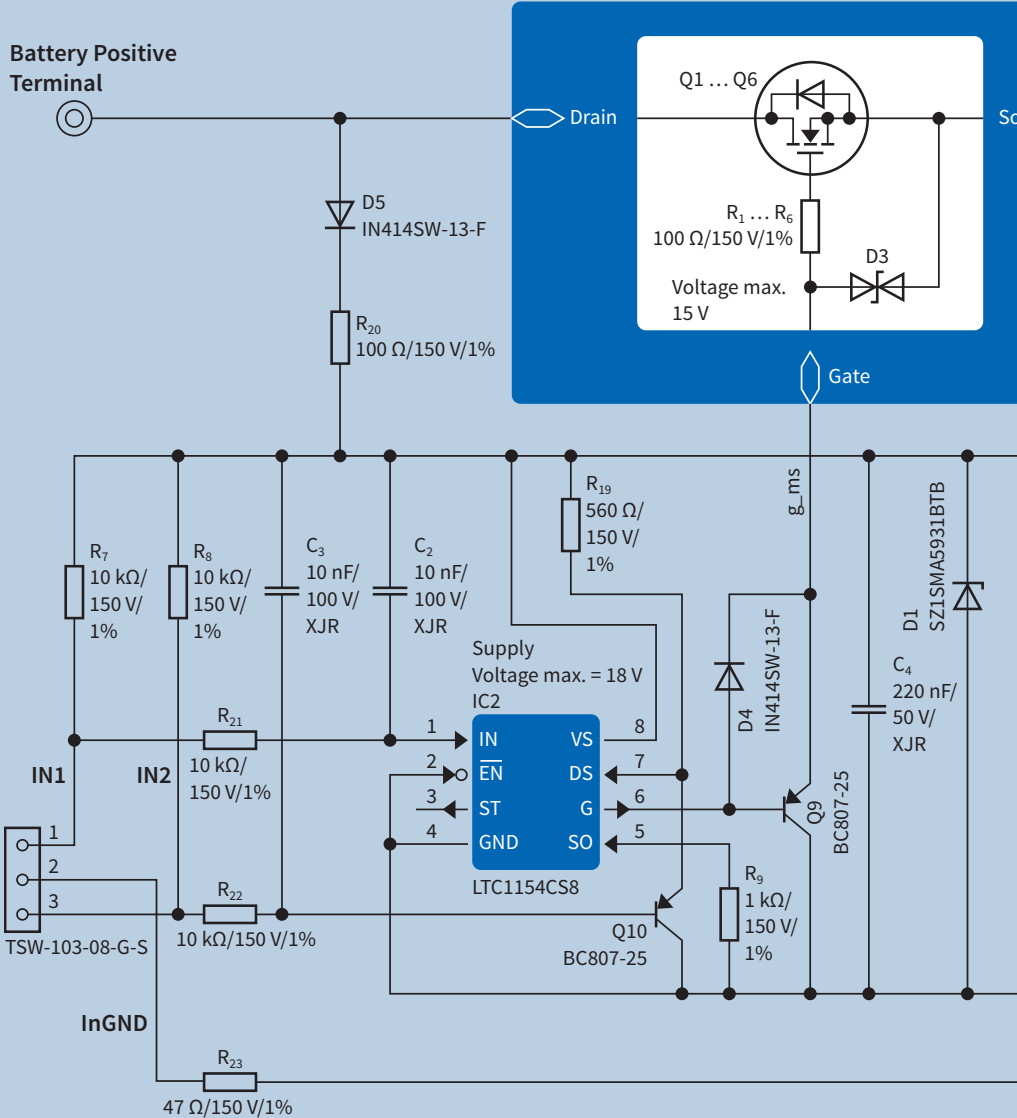

Output Terminal

Power
Clamp

Source

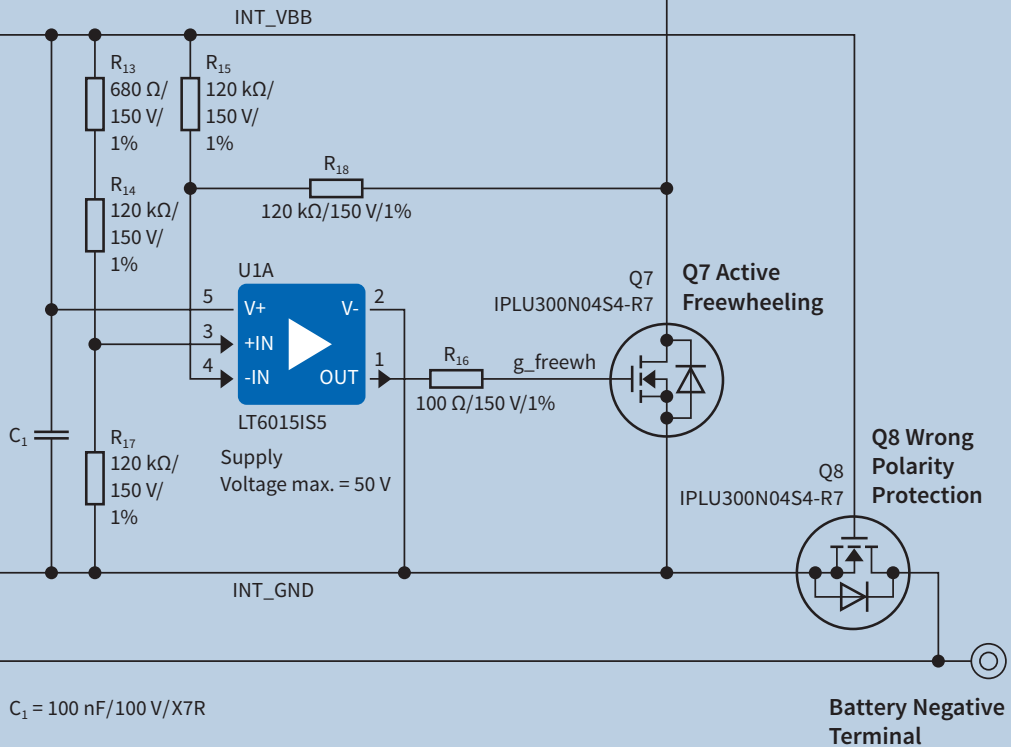

Schematic

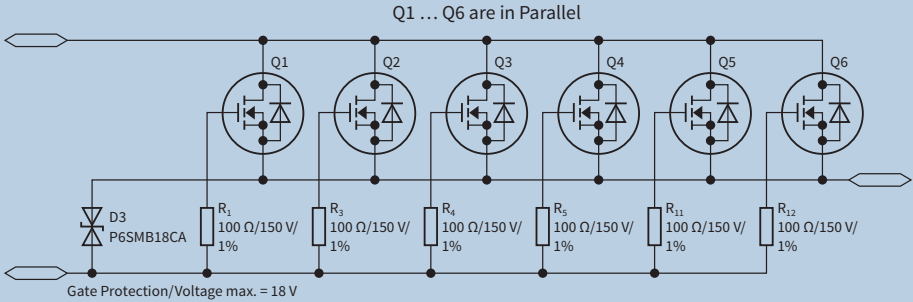

How to Connect the SBS

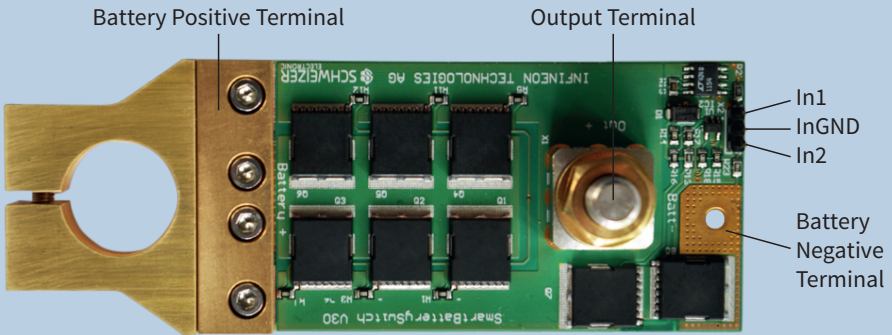

IN1	IN2	Switch
N.C.	N.C.	On
L	N.C.	Off
N.C.	L	Off (latched)
	N.C.	Reset latched

N.C. = Not connected

L = Connected to InGND

= Pull down In2 to InGND and release again



Thermal Image after 10 minutes and 250A.

www.infineon.com/smart-battery-switch

www.infineon.com/mosfet

Order Number: DEMO_BATT_SW_V3 SP001332050

© 2015 Infineon Technologies AG. All Rights Reserved.

X-ON Electronics

Largest Supplier of Electrical and Electronic Components

Click to view similar products for [Power Management IC Development Tools](#) category:

Click to view products by [Infineon](#) manufacturer:

Other Similar products are found below :

[EVAL-ADM1168LQEBZ](#) [EVB-EP5348UI](#) [MIC23451-AAAYFL EV](#) [MIC5281YMME EV](#) [DA9063-EVAL](#) [ADP122-3.3-EVALZ](#) [ADP130-0.8-EVALZ](#) [ADP130-1.2-EVALZ](#) [ADP130-1.5-EVALZ](#) [ADP130-1.8-EVALZ](#) [ADP1712-3.3-EVALZ](#) [ADP1714-3.3-EVALZ](#) [ADP1715-3.3-EVALZ](#) [ADP1716-2.5-EVALZ](#) [ADP1740-1.5-EVALZ](#) [ADP1752-1.5-EVALZ](#) [ADP1828LC-EVALZ](#) [ADP1870-0.3-EVALZ](#) [ADP1871-0.6-EVALZ](#) [ADP1873-0.6-EVALZ](#) [ADP1874-0.3-EVALZ](#) [ADP1882-1.0-EVALZ](#) [ADP199CB-EVALZ](#) [ADP2102-1.25-EVALZ](#) [ADP2102-1.875EVALZ](#) [ADP2102-1.8-EVALZ](#) [ADP2102-2-EVALZ](#) [ADP2102-3-EVALZ](#) [ADP2102-4-EVALZ](#) [ADP2106-1.8-EVALZ](#) [ADP2147CB-110EVALZ](#) [AS3606-DB](#) [BQ24010EVM](#) [BQ24075TEVM](#) [BQ24155EVM](#) [BQ24157EVM-697](#) [BQ24160EVM-742](#) [BQ24296MEVM-655](#) [BQ25010EVM](#) [BQ27411EVM-G1A](#) [BQ3055EVM](#) [NCV891330PD50GEVB](#) [ISLUSBI2CKIT1Z](#) [LM2744EVAL](#) [LM2854EVAL](#) [LM3658SD-AEV/NOPB](#) [LM3658SDEV/NOPB](#) [LM3691TL-1.8EV/NOPB](#) [LM4510SDEV/NOPB](#) [LM5033SD-EVAL](#)