

BCR601 engineering report

Engineering report for 60 V, 500 mA linear LED controller demonstration board

About this document

Scope and purpose

This document presents a demonstration board (DEMO_BCR601_60V_IVCTRL) design for BCR601, a 60 V linear LED controller IC for dimmable LED driver with voltage feedback to the primary side also known as Active Headroom Control (AHC). The document also describes the configuration of the voltage control loop and the current control loop via external components. The IC is available in a PG-DSO-8 package.

Intended audience

This document is intended for design engineers, system and concept engineers, application engineers and students who need to design cost-efficient, highly reliable, dimmable and power-optimized LED drivers.

Table of contents

	About this document	1
1	Introduction	3
2	List of features of the demonstrator system	5
3	Circuit description	6
3.1	Circuit diagram	6
3.2	Component description	8
3.3	PCB layout	9
3.4	LED load	9
4	Test results	10
4.1	Test setup	10
4.2	Current ripple suppression	11
4.3	Start-up	12
4.4	Dimming	14
4.4.1	DC voltage dimming	15
4.4.2	R _{set} dimming	17
4.5	Protections	17
4.5.1	Hot-plug	17
4.5.2	Short of LEDs	18
4.5.3	Overtemperature protection OTP	19
4.5.4	Over-Voltage Protection (OVP)	19
4.6	Thermal tests	20
4.6.1	Option TO-220 package	22
4.6.2	Option DPAK (TO-252) package	22
4.7	Efficiency and harmonics	23
4.7.1	Efficiency	23



Table of contents

4.7.2	Harmonics and power factor	24
5	Bill of Materials (BOM)	25
6	Related links and support material	29
	Disclaimer	30

1 Introduction

1 Introduction

This is an engineering report for a linear LED driver demonstration board operated in combination with an Infineon XDPL8218 PFC/Flyback controller.

The board is operable up to 60 V input voltage. In the standard configuration the target current is 500 mA. The PFC/Flyback represents the primary side of the LED power supply while the BCR601 system of the demonstration board represents the secondary side. Both sides are separated by galvanic decoupling. To the primary side an *OPTO* closed-loop feedback control signal is provided. This document contains the technical specification for the LED driver, a description of the main features and circuit and layout descriptions, as well as the measurement results.

In this application an Infineon BCR601 is used as an LED driver IC. The system contains two independent control loops.

- A current control loop regulating and dimming the LED current
- A voltage control loop regulating the input voltage to the board

The current control loop controls an external transistor. This is a MOSFET or a BJT. The LED current is fully scalable by dimensioning an external Current Sense (CS) resistor. BCR601 suppresses the voltage ripple of the power supply driving a constant LED current for better light quality. The LED current can be dimmed by resistors as well as by analog voltages connected to the Multi Function Input Output (*MFIO*) pin.

The embedded hot-plug protection allows plug-in and plug out of any LED load during operation.

The LED current level can be adjusted up to 1.5 A by connecting up to three shunt resistors at pin *VSENSE*. This also sets the default LED current to up to 500 mA in case of the used effective resistor of R11, R12 and R13 of 800 mΩ.

The voltage drop at *VSENSE* caused by the shunt resistors is 400 mV or less in case of dimming, improving the overall system efficiency and providing extra voltage headroom to compensate for tolerances of LED forward voltage or supply voltage.

The *OPTO* pin can sink up to 4 mA of opto current for feedback to the primary side of the controller.

A smart Over Temperature Protection (OTP) function reduces the LED current when the junction temperature of BCR601 gets too high.

An Over-Voltage Protection provides a fast reaction of the feedback signal in case of over-voltage at the input.

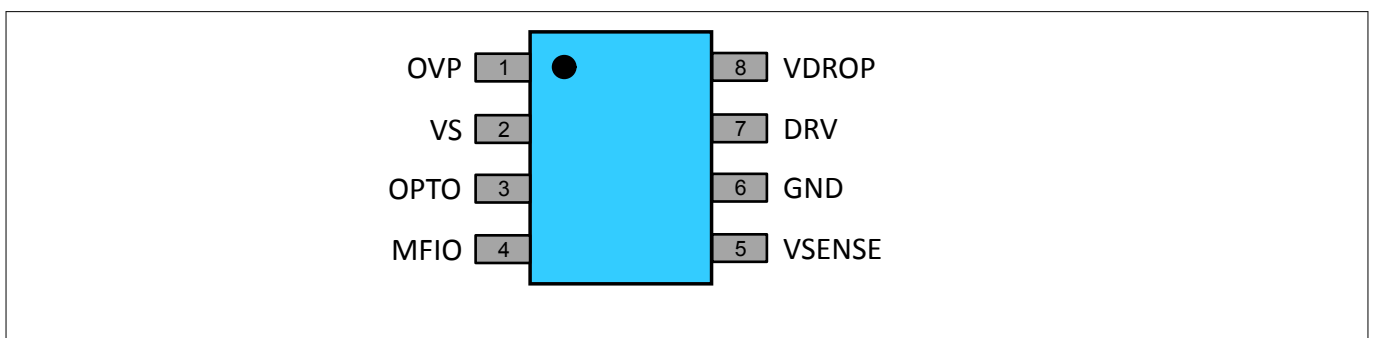

Figure 1 Pin configuration

1 Introduction



Figure 2 Top side of the demonstrator design board (61.00 mm x 27.00 mm)

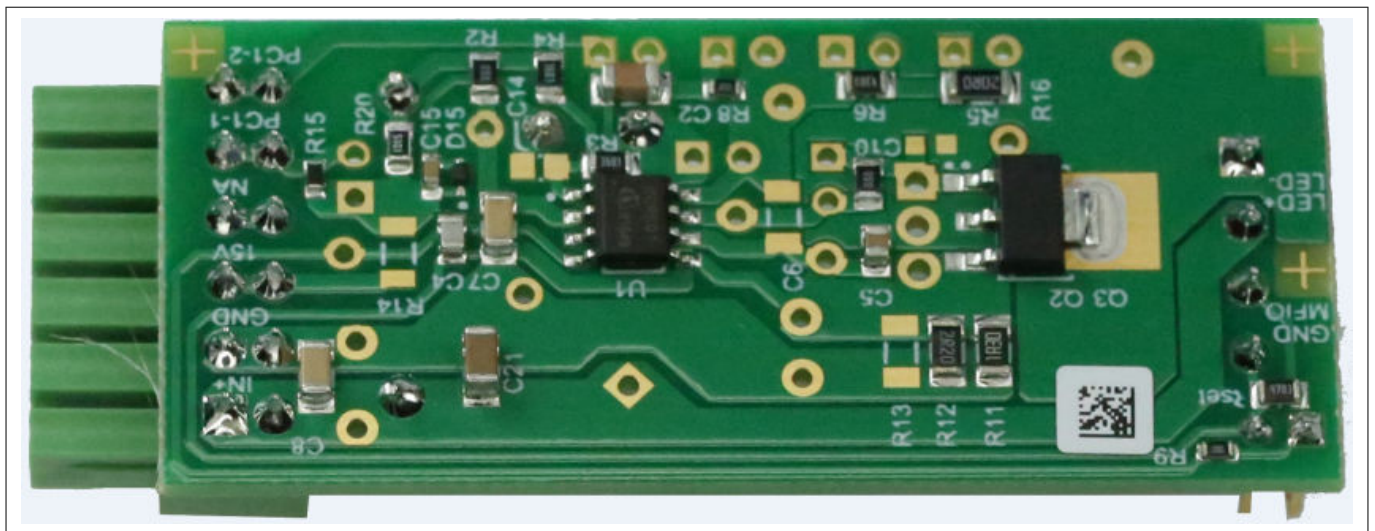

Figure 3 Bottom side of the demonstrator design board (61.00 mm x 27.00 mm)

2 List of features of the demonstrator system

2 List of features of the demonstrator system

Table 1 List of features

Supply voltage from 8 V to 60 V
Supports use of NPN bipolar transistors and NMOSFETs
100 Hz/120 Hz supply voltage ripple suppression
Supports an optocoupler feedback loop to primary side minimizing power losses
3 percent analog dimming of LED current by a resistor or DC voltage at the MFIO pin
R_{set} functionality at pin <i>MFIO</i>
LED current precision ± 3 percent
Hot-plug protection to minimize LED inrush current
OVP
OTP

Table 2 Board specification

Parameter	PCB ID	Value
Feature element		
Input voltage	IN+	8 V to 60 V
Default LED current	IN+, LED-, R11, R12, R13	500 mA
Current configuration resistor R_{VSENSE}	R11, R12, R13	800 m Ω (greater than or equal to 400 m Ω effective resistance recommended)
Number of LEDs supplied	N/A	Up to 18 LEDs in series (, strings up to 20 LEDs tested)
Device dimensions	N/A	61.00 mm x 27.00 mm (L x W)

3 Circuit description

3 Circuit description

This section describes the application and the circuit of the BCR601 demonstrator design.

3.1 Circuit diagram

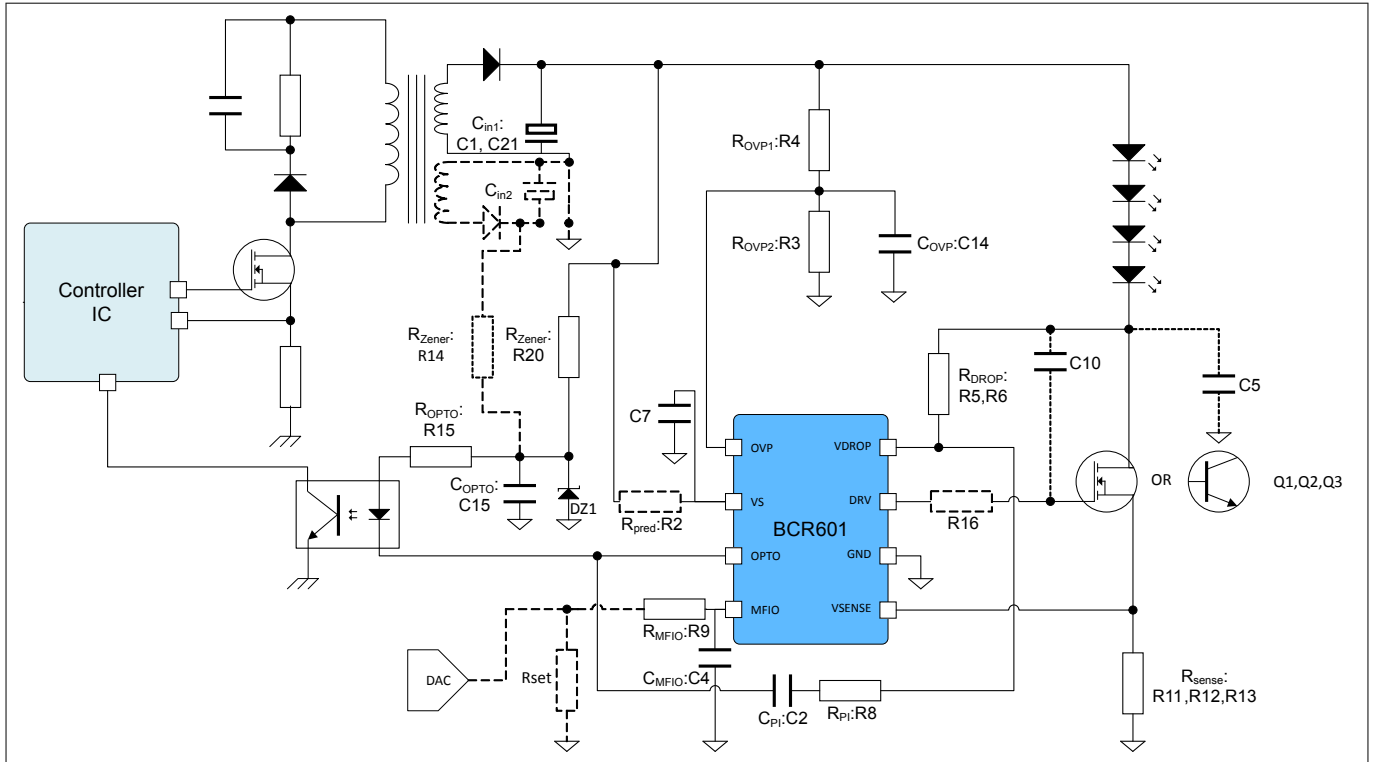

Figure 4 Schematic diagram of a BCR601 linear LED driver application with voltage control feedback to the primary side

3 Circuit description

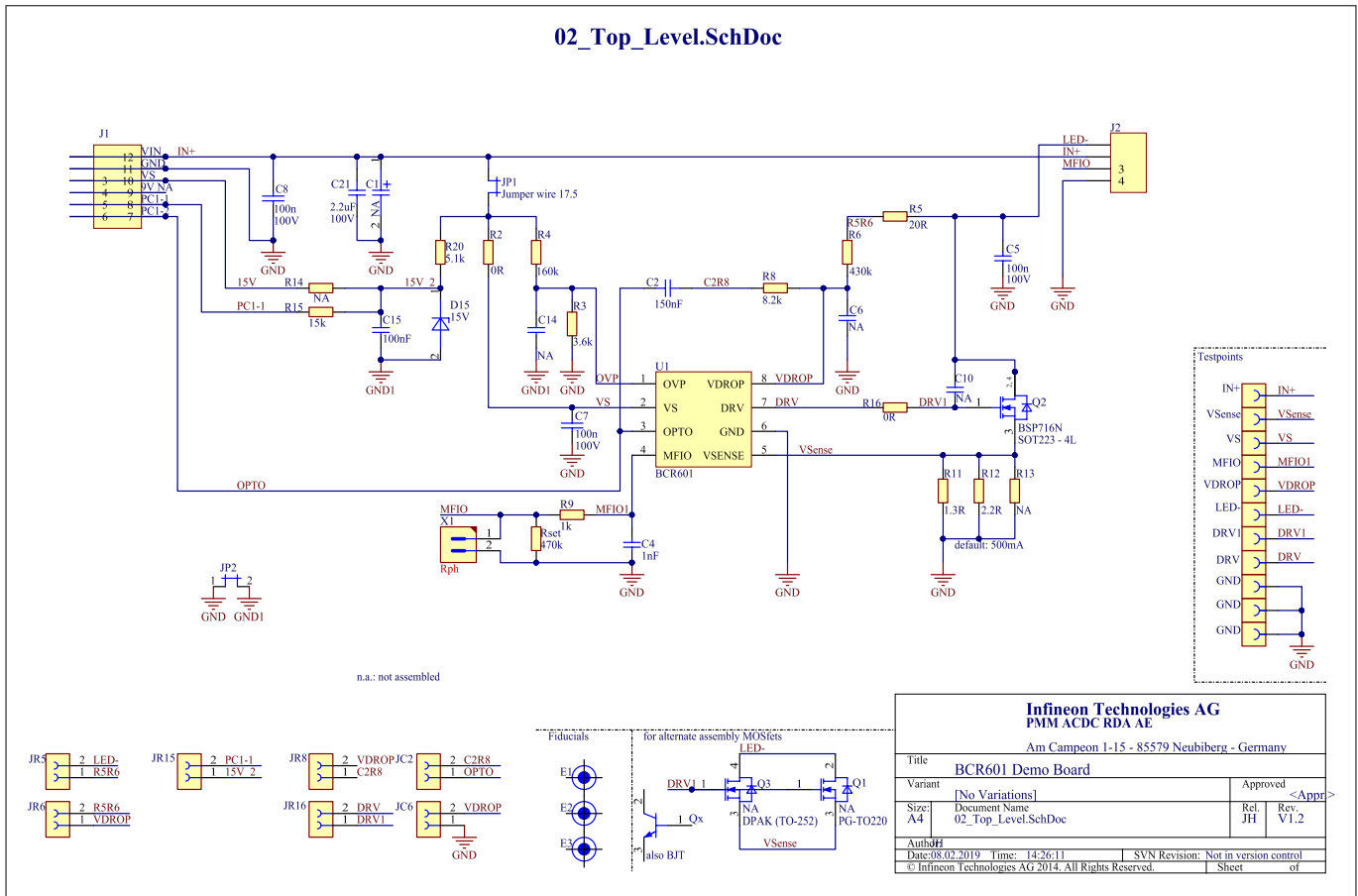

Figure 5 BCR601 PCB schematics

IN+: C1, C21 are input capacitors for spike and ripple suppression. C21 is an SMD component while C1 is a wired electrolytic capacitor. In the demonstrator design C21 is populated with a ceramic capacitor.

In case of a too-high power-supply output voltage ripple an electrolytic capacitor can be assembled using C1 to partially suppress the ripple and improve input signal quality.

The MFIO input signals are low-pass filtered by a first-degree filter consisting of R9 and C4.

In the demonstrator design IC power protection resistor R2 is assembled with 0 Ω.

OVP is assembled by resistors R3 and R4. For spike suppression capacitor C14 can be assembled. In the demonstrator design the capacitor is not assembled. Using the voltage regulation loop the voltage at the OVP pin must not be lower than 100 mV. The default setting is R3 = 3.6 kΩ and R4 = 360 kΩ for an over-voltage threshold of 52.3 V. In the given configuration at 8 V input voltage $U_{OVP} = 223$ mV. With the assembled configuration of the demonstrator the system can be operated down to its minimum input voltage. For a trigger threshold above the maximum input voltage of 60 V keeping R4 constant at 360 kΩ, R3 must be reduced below 3.1 kΩ.

Voltage control loop (feedback) is assembled by components C2 and R8, with components R5 and R6 configuring V_{DRAIN} . C6 is not assembled.

Capacitor C5 supports the stability of the current loop in case of long connecting cables. In the demonstrator design it is assembled with 100 nF.

Current loop behavior can be influenced by capacitor C10 and resistor R16. C10 represents a Miller capacitor.

The MOSFET or the BJT is assembled using:

- Q1 for package TO-220
- Q2 for package DPAK/TO-252
- Q3 for package SOT223

3 Circuit description

The maximum current is set by resistors R11, R12 and R13.

OPTO current is limited by resistor R15. The Zener diode D15 limits the input voltage into the *OPTO* path to 15 V. The maximum current via the *OPTO* path and the Zener diode is limited by resistor R20. Resistor R14 used for the same purpose in case of an auxiliary supplied *OPTO* path is not assembled.

3.2 Component description

This section gives an overview of the technical specification of the BCR601 demonstration board.

Table 3 Component description

Component	PCB ID	Value
Feature elements		
Default input capacitor C_{IN}	C21	2.2 μ F
Supported transistor packages	Q1, Q2, Q3	<ul style="list-style-type: none"> • TO-220AB • PG-SOT223 • D-PAK, TO-252AA
Default VS protection resistor R_{PRED}	R2	0 Ω
Capacitor for loop stability improvement	C5	100 nF
Voltage regulator (PI)		
C_{PI}	C2	150 nF
C_{DROP}	C6	N/A
R_{DROP}	R6	430 k Ω
R_{PI}	R8	8.2 k Ω
R_{OPTO}	R15	15 k Ω
R_{Zener}	R20	5.1 k Ω
R_{Zener} , auxiliary supply	R14	N/A
C_{OPTO}	C15	100 nF
Bode test resistor	R5	20 Ω
Current control		
Current configuration resistors, effective resistance R_{SENSE}	R11, R12, R13	800 m Ω , assembled $R_{SENSE} = 0.82 \Omega$, R11 = 1.3 Ω , R12 = 2.2 Ω
Optional RC element	C10	N/A
	R16	0 Ω
Overvoltage protection (OVP)		
$R_{OVP,1}$	R4	160 k Ω
$R_{OVP,2}$	R3	3.6 k Ω
C_{OVP}	C14	N/A
ESD		
ESD protection BCR601 IC	C7	100 nF

3 Circuit description

Table 3 Component description (continued)

Component	PCB ID	Value
Dimming		
R_{MFIO}	R9	1 k Ω
C_{MFIO}	C4	1 nF
R_{set} range	R_{set}	10 k Ω to 620 k Ω , assembled 470 k Ω , enabling 100 % I_{LED} in case of no external voltage applied to pin <i>MFIO</i> .

The Bode test resistor is used to connect the Bode probes. The resistor has no effect on behavior of the regulation loop and can be replaced by 0 Ω in case of reference designs.

Technically BCR601 and the evaluation PCB are also able to handle higher LED currents. In the verification phase, due to the nature of the PFC/Flyback solution used, current was limited to 1 A.

3.3 PCB layout

The PCB is single-sided, and is manufactured with the standard 1.5 mm thickness and 1 oz copper. It measures 61 mm x 27 mm.

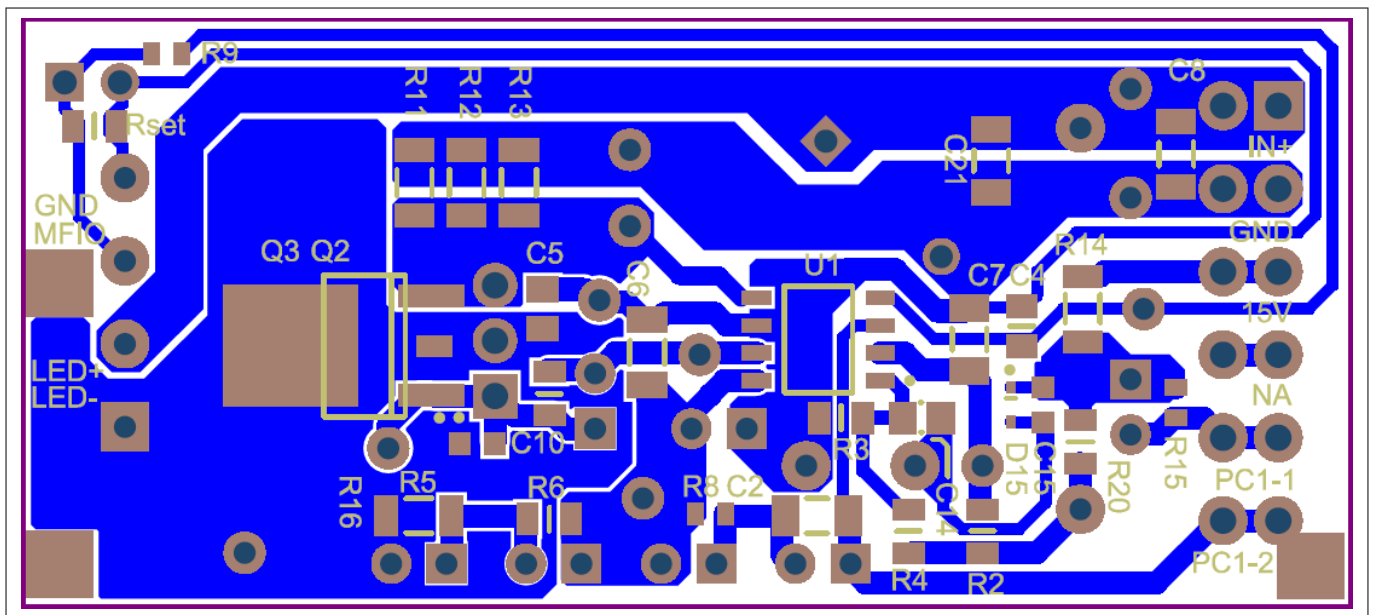

Figure 6 Layout bottom

3.4 LED load

This section describes the LED load used as a reference load and connected to the demonstration board during evaluation.

The BCR601 demonstration board is operated with an LED test load of up to 20 LEDs. The test load contains 20 LEDs of type OSRON Square, v1.4, GW CSSRM1.PC with a maximum operating forward current of 1800 mA.

The BCR601 was tested with 8 to 14 LEDs at the given current configuration as well a with alternative target current configurations and alternative types of power transistors.

4 Test results

4 Test results

This section lists tests results and descriptions of application features.

4.1 Test setup

In the demonstrator BCR601 is operated in combination with an XDPL8218 PFC/Flyback.

Note: BCR601 together with XDPL8218 represents the reference system design of this engineering report. BCR601 can be operated with any other primary-side AC-DC controller supplying a DC input signal, including some AC offset at the desired power level.

In the system:

- XDPL8218 acts as PFC/Flyback on the primary side
- BCR601 acts as a controller of the voltage loop on the secondary side
- XDPL8218 is a high power factor constant voltage Flyback IC

Key features of XDPL8218:

- Single-stage Flyback controller with Power Factor Corrections (PFC)
- Secondary Side Regulated (SSR) constant voltage (CV) output
- Avoids audible noise
- Supports extended voltage range from 90 V AC to 305 V AC
- Power factor greater than 0.9, THD less than 15
- Meets IEC 61000-3-2 class C requirements
- DSO-8 package
- Stand-by power less than 100 mW
- Device selects optimum between QR, discontinuous conduction or burst mode

Figure 7 shows on the left hand side the XDPL8218 system on the primary side and on the right-hand side the BCR601 system on the secondary-side is seen.

Figure 8 shows the pinning of the connectors between the XDPL8218 system and the BCR601 system.



Figure 7 XDPL8218 BCR601 system - top side

4 Test results

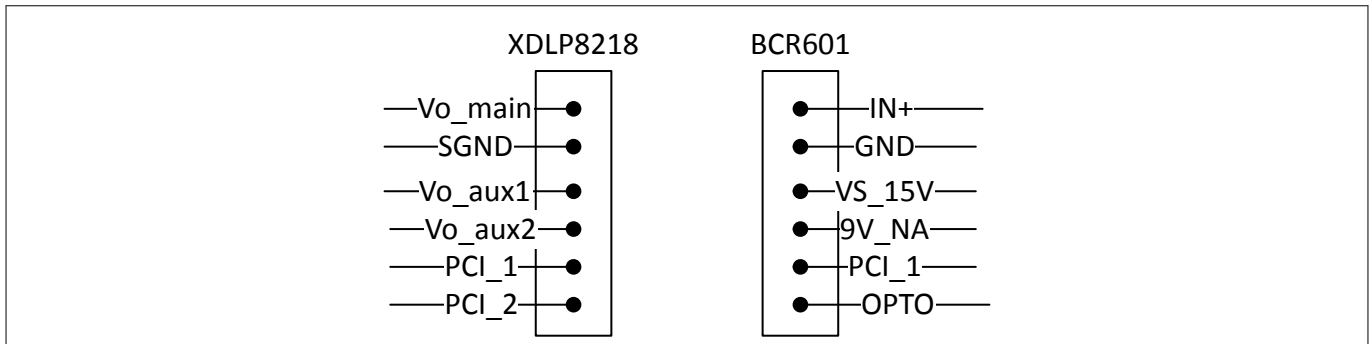

Figure 8 Connector interface XDPL8218 to BCR601

Up to 60 V DC source is supplied between ports IN+ and LED-. The external LED load is connected to ports LED+ and LED-.

Analog dimming signals are applied to the MFIO pin.

The IC can also be supplied separately via port 15 V.

The optocoupler for feedback transfer to the primary side is connected to the PCI-1 and OPTO ports.

4.2 Current ripple suppression

Figure 9 shows the target current in case of an AC offset on the DC input signal. The input ripple has a frequency of 120 Hz.

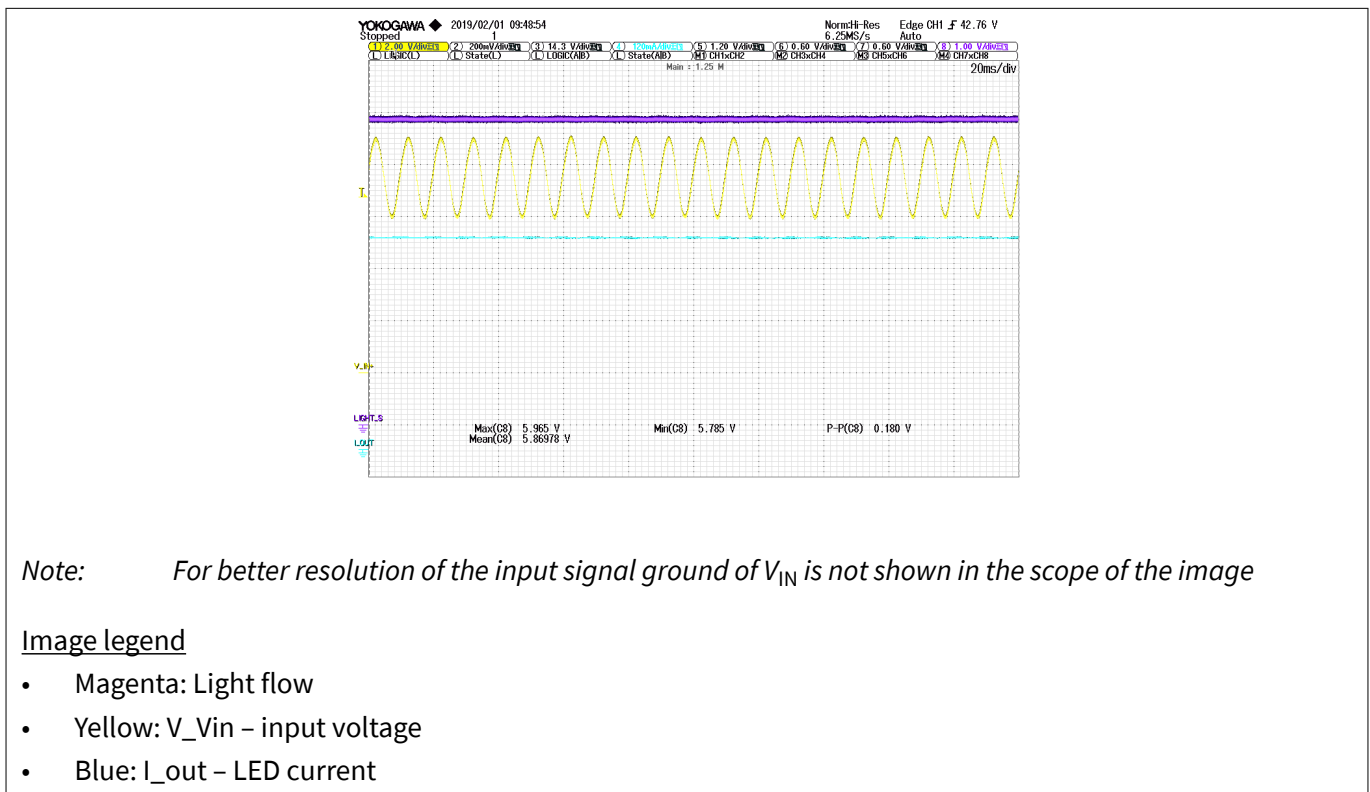

Figure 9 V_{SENSE} ripple suppression at $V_{MFIO} = 4.0 V$, 14 LEDs OSRON Square

The peak-to-peak value is maximum at no dimming and decreases the more the system is dimmed. Voltage ripple suppression was tested up to 8 V_{pp} and over an AC input frequency range from 40 Hz up to 70 Hz. Flickering is measured using an optical sensor showing the intensity of the light flow.

4 Test results

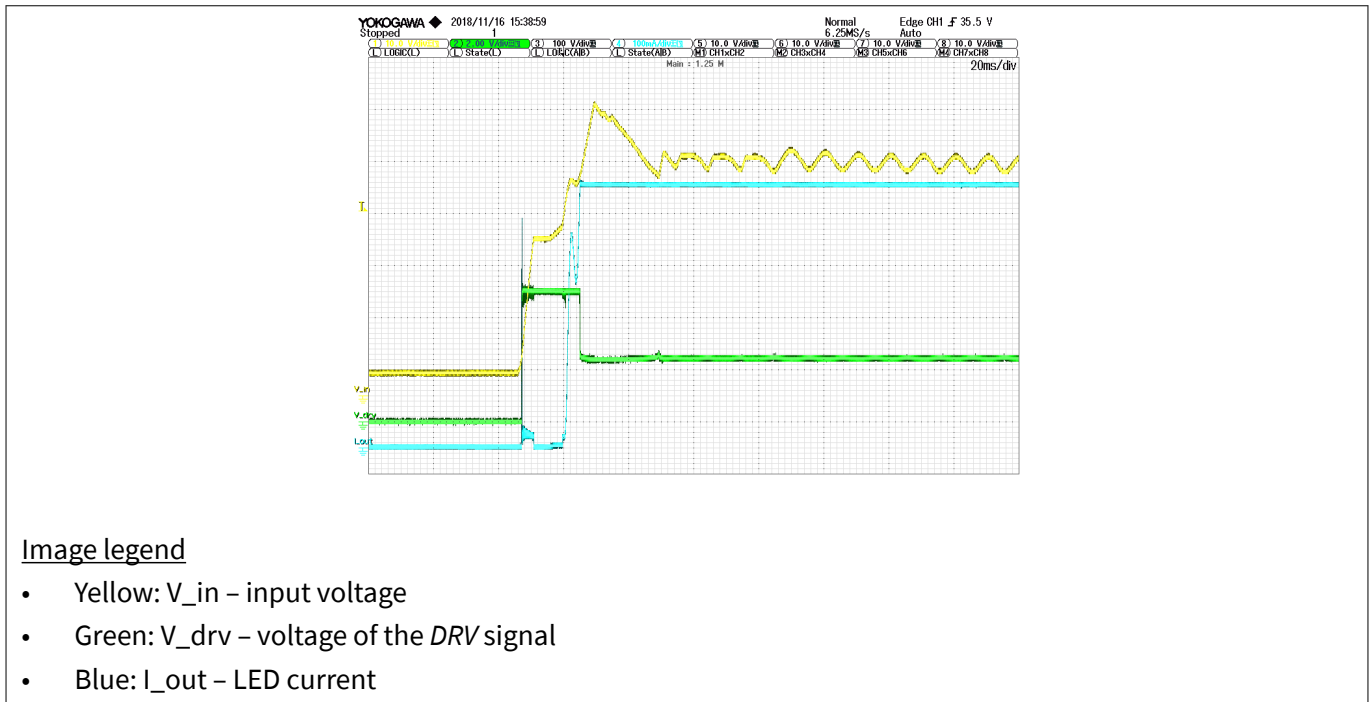

Figure 10 Current ripple suppression at start-up

Figure 10 shows the current ripple suppression at start-up and no-dimming conditions. 14 OSLO Square LEDs were driven in this case. The current is regulated to its target value as soon as the input voltage is sufficiently high to compensate for the forward voltage of the LED diodes. The DRV signal jumps to its maximum value after release of the device reset and regulates to the set-point as soon as the minimum required input voltage is achieved. Ripple suppression has been tested up to 16 V_{pp}.

4.3 Start-up

This section describes the startup behavior of a BCR601 LED system.

The start-up time is defined as the time delta from the point of time at which V_{IN+} exceeds the minimum supply voltage and the point of time at which V_{SENSE} reaches 80 percent of the target value. In the undimmed case the latter is a value of 320 mV.

Figure 11 shows the OPTO circuit in case of a single supply voltage. **Figure 12** shows a start-up of the demonstrator design powering 14 LEDs using a single supply voltage.

4 Test results

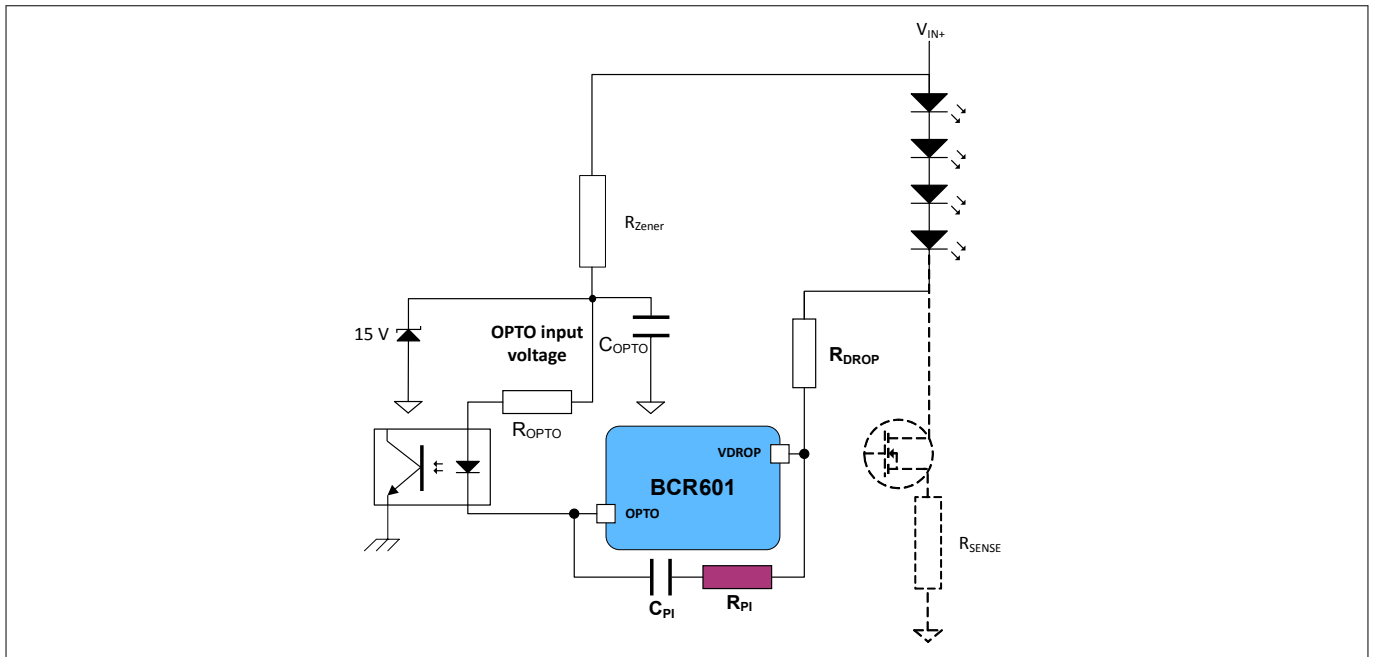

Figure 11 Single supply OPTO circuit

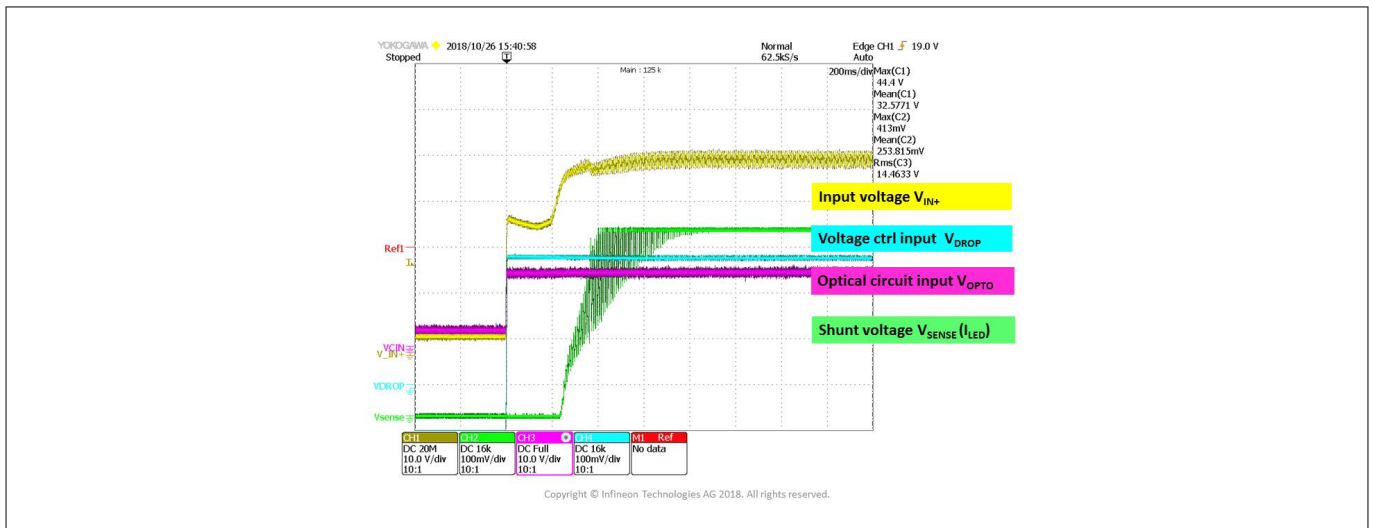

Image legend

- Yellow: V_{IN} – input voltage
- Blue: V_{DROP} – input into the voltage controller
- Magenta: V_{OPTO} – input into the OPTO path
- Green: V_{SENSE} – CS voltage

Figure 12 Start-up demonstrator design in case of single supply

Start-up in case of second supply voltage

XDPL8218 PFC/Flyback offers a second supply voltage of 15 V. This supply can be used to power the OPTO path and is considered the first choice. **Figure 13** shows the circuit in case of a second voltage supply.

4 Test results

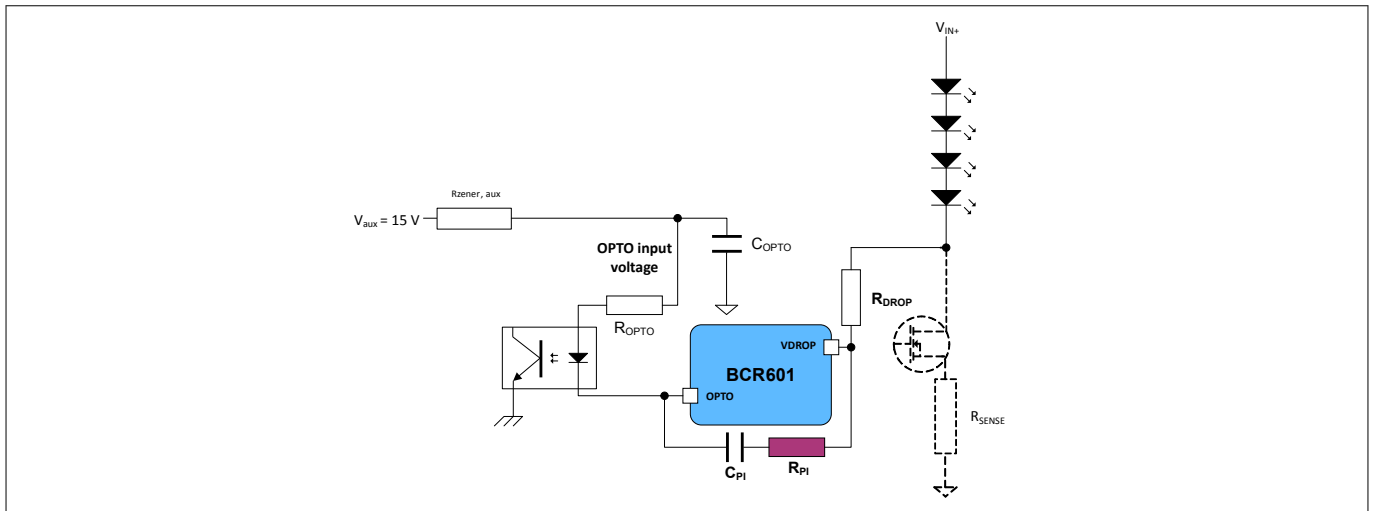

Figure 13 OPTO circuit with auxiliary supply

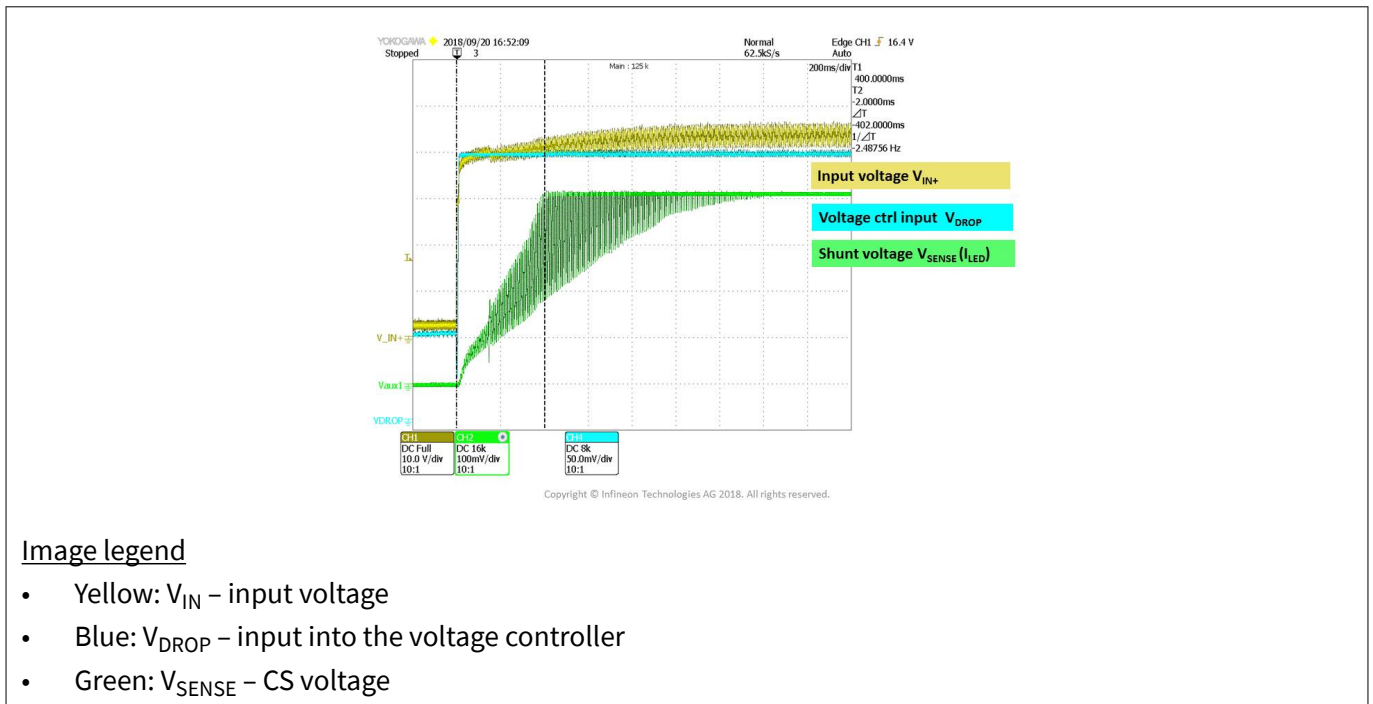

Image legend

- Yellow: V_{IN} – input voltage
- Blue: V_{DROP} – input into the voltage controller
- Green: V_{SENSE} – CS voltage

Figure 14 System start-up with second supply voltage for OPTO path

With increasing size of the time constant τ consisting of C_{PI} ($C2$) and R_{DROP} ($R6$), the start-up time increases. Indirectly start-up time also depends on the number of LEDs, because a higher number of LEDs requires a higher input voltage.

4.4 Dimming

This section describes the dimming options of BCR601.

BCR601 provides these dimming options:

- DC dimming by applying a variable external voltage to the *MFIO* pin
- R_{set} dimming to a fixed dimming value by connecting a resistor between the *MFIO* pin and ground

4 Test results

4.4.1 DC voltage dimming

A BCR601 system enables DC voltage dimming over the whole range without causing flickering at any voltage level.

Figure 15 shows the DC dimming curve depending on the input voltage at the *MFIO* pin. At the lower end of the dimming curve hysteresis provides a shut-off at a lower *MFIO* voltage compared to the *MFIO* switch-on voltage.

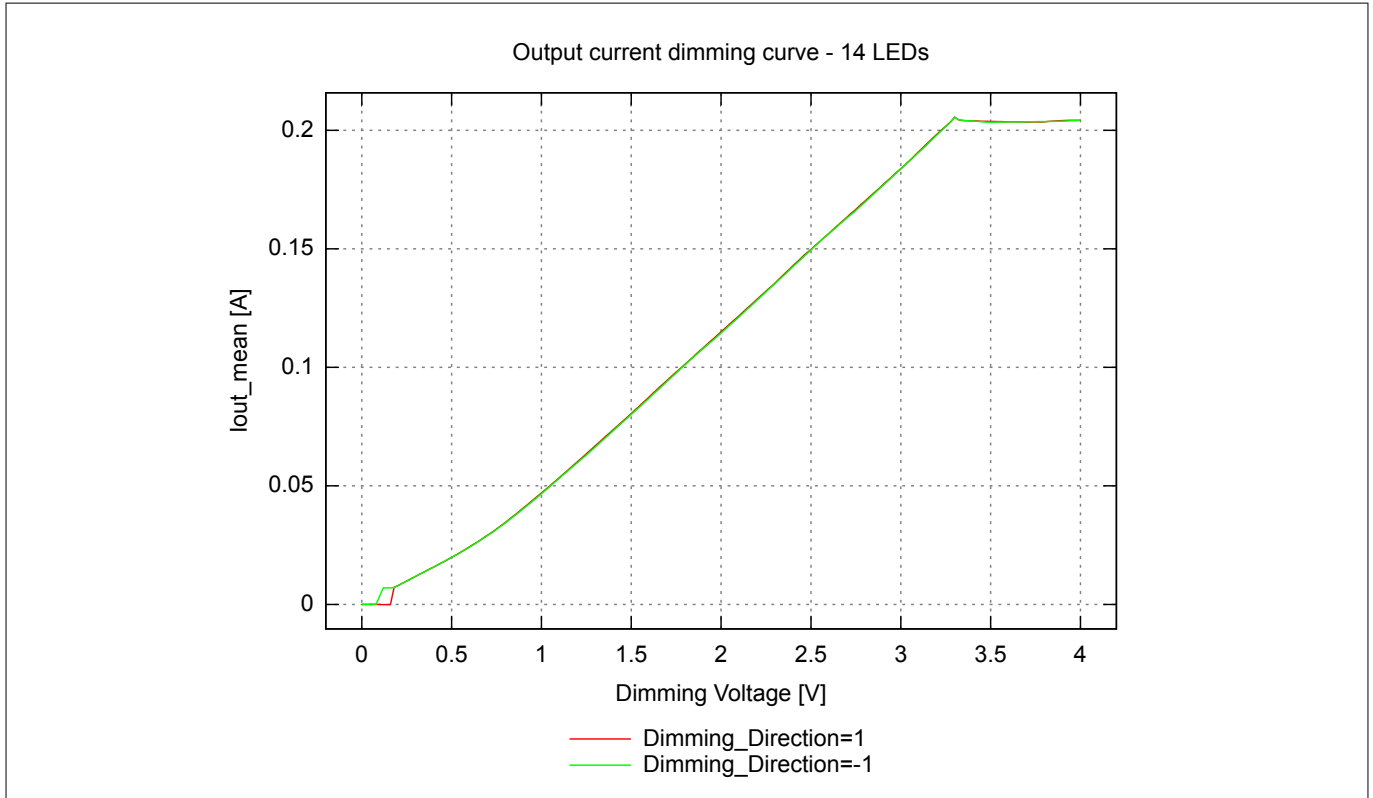

Figure 15 DC voltage dimming curve

Figure 16 shows dimming in the hysteresis range. In the phases with a negative slope of V_{MFIO} the current is shut off at $V_{MFIO} = 120$ mV. This is at the minimum level of V_{MFIO} and just at the shut-off level. V_{SENSE} at this level is 14 mV compared to the default of 400 mV in the no dimming case. At the rising slope of V_{MFIO} V_{SENSE} jumps from 0 V to 14 mV at the shut-on level of $V_{MFIO} = 180$ mV.

4 Test results

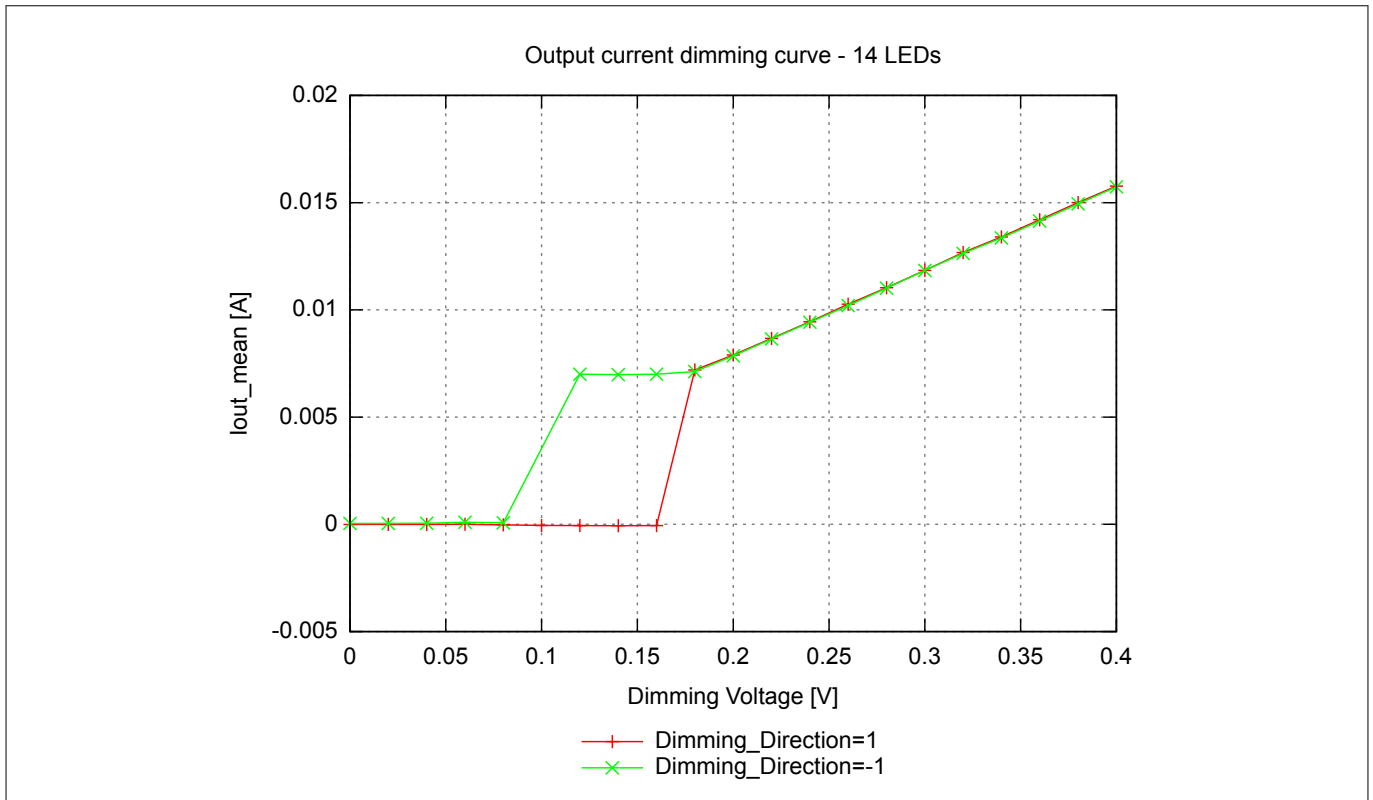

Figure 16 Hysteresis

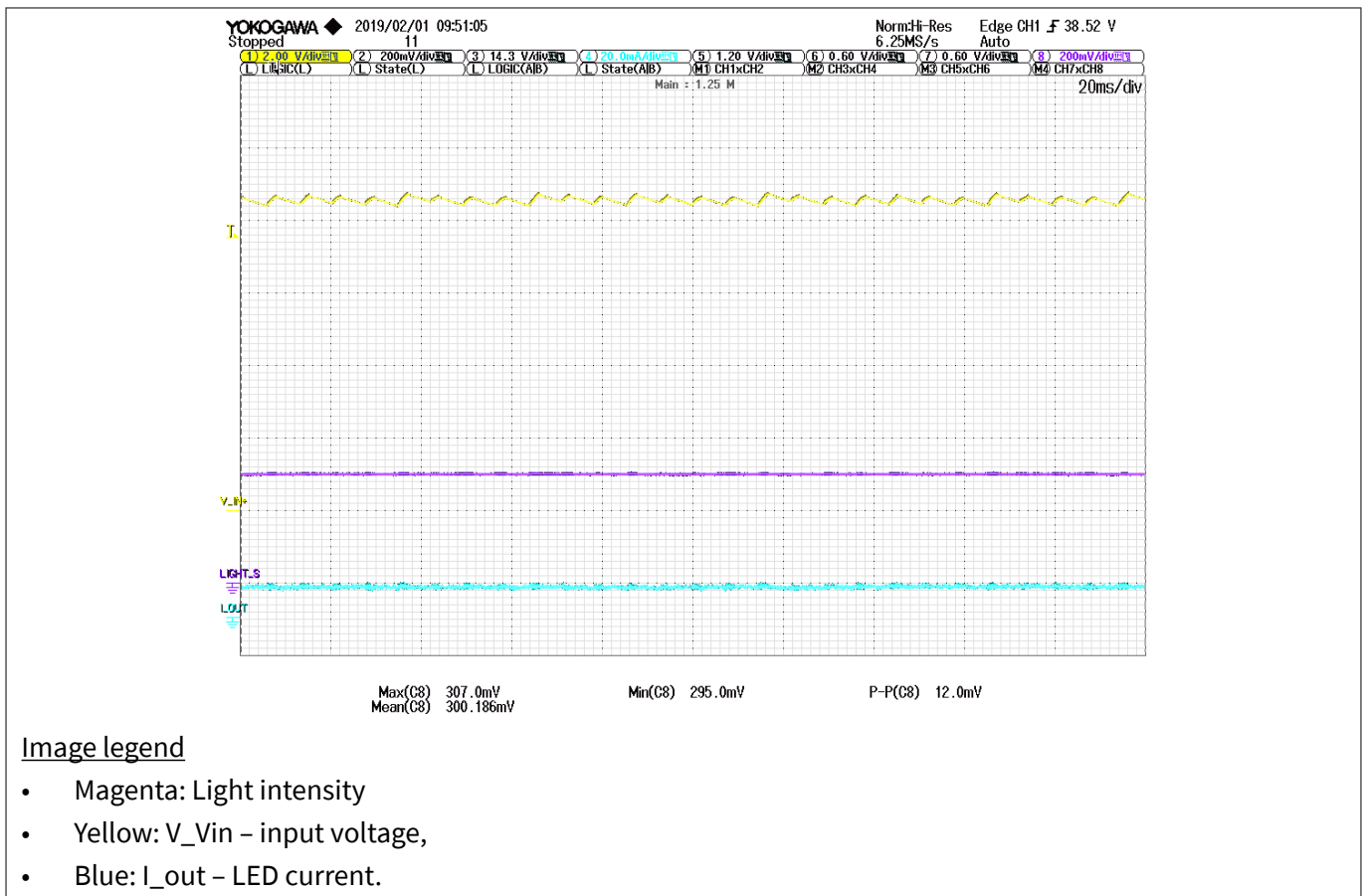

Image legend

- Magenta: Light intensity
- Yellow: V_Vin – input voltage,
- Blue: I_out – LED current.

Figure 17 V_{SENSE} ripple suppression at V_{MFO} = 0.18 V, 14 LEDs OSLO[®] Square

4 Test results

Figure 17 shows the current loop suppression of the input ripple at maximum dimming input. In this case, due to the low power demand at high-dimming the XDPL8218 PFC/Flyback is operated in burst mode. This causes the non-sinusoidal triangle-edged input voltage signal.

Flicker is measured using an optical sensor. The light intensity show no remains of the ripple.

4.4.2 R_{set} dimming

This section describes the dimming to a fixed value using a resistor.

Figure 18 shows the measurement results of $MFI0$ dimming values compared to the calculated results. The equation of the calculated results can be found in the datasheet. The deviation between the measured and the calculated curve is based on component variation. The LED current level can be adjusted by placing varying R_{set} resistors.

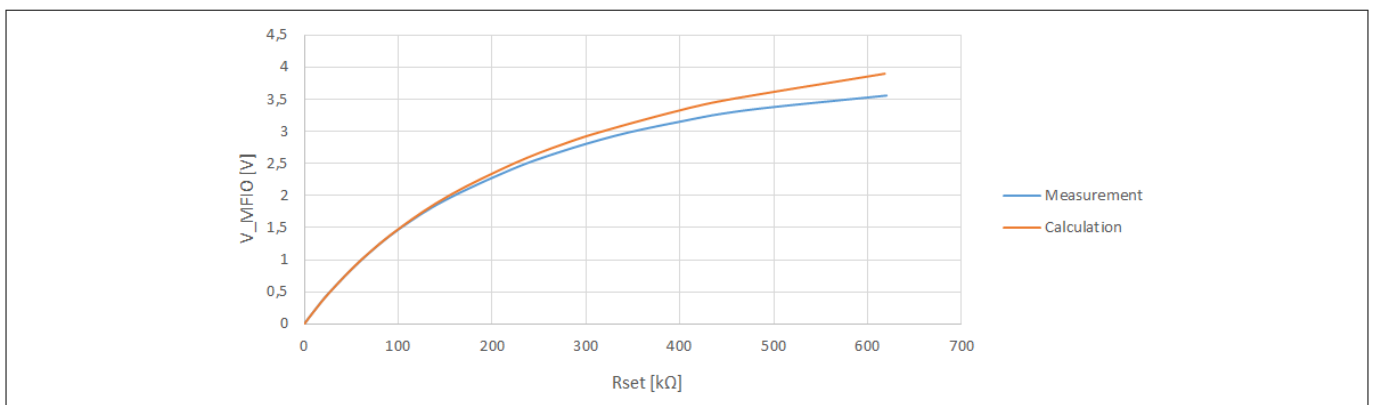

Figure 18 R_{set} measurement results

4.5 Protections

BCR601 offers protection features for hot-plug, stable current in case of shorts of LEDs, OTP, OVP.

Hot-plug, short and over-temperature protections are independent of the system configuration. OVP is configured depending on the system input voltage level. The voltage input level depends on the number of LEDs present in the system.

4.5.1 Hot-plug

Hot plug protection allows plug-in and plug-out of any LED load during operation without damaging the LEDs by surge currents.

A hot-plug condition is detected and activated by a V_{SENSE} falling below the threshold of 8 mV. Its purpose is the controlled power-up of the system until stable operating conditions are reached.

Figure 19 a hotplug event.

- In the time before the hot-plug the voltage control loop is at a value above the set-point
- Due to slower voltage control compared to current control the input capacitor of the BCR601 system gets discharged
- For ~250 ms drops of I_{LED} are seen. These drops are synchronous with the ripple on the AC signal and are caused by phases of V_{IN} under-voltage

4 Test results

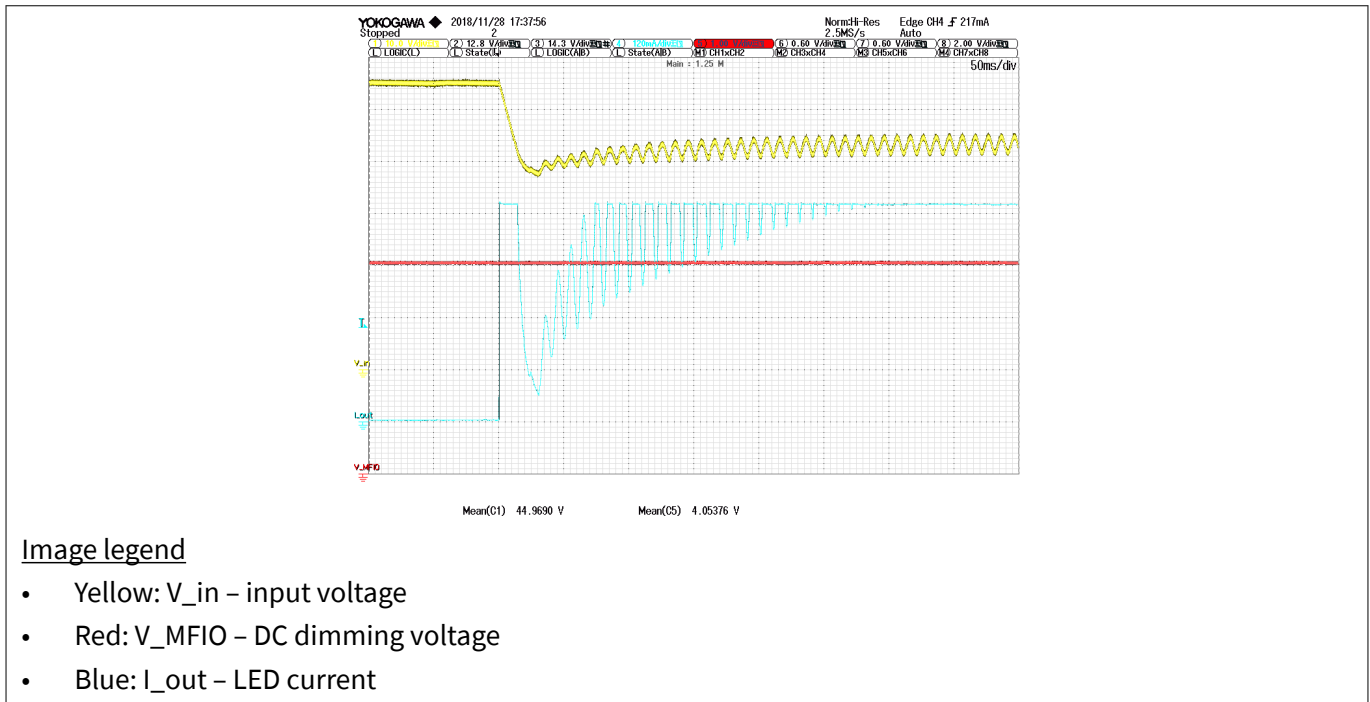

Figure 19 Hot-plug 12 LEDs

4.5.2 Short of LEDs

BCR601 is capable of handling shorts of LEDs without hazard to the system.

Shorts of up to three LEDs have been tested. In all cases no disturbance of the LED current is seen.

Because of the fast reaction of the current control loop no change in current is seen. Because of the constant input voltage with respect to the time scale of the current control, at the short of the LEDs the voltage drop over the transistor temporary increases.

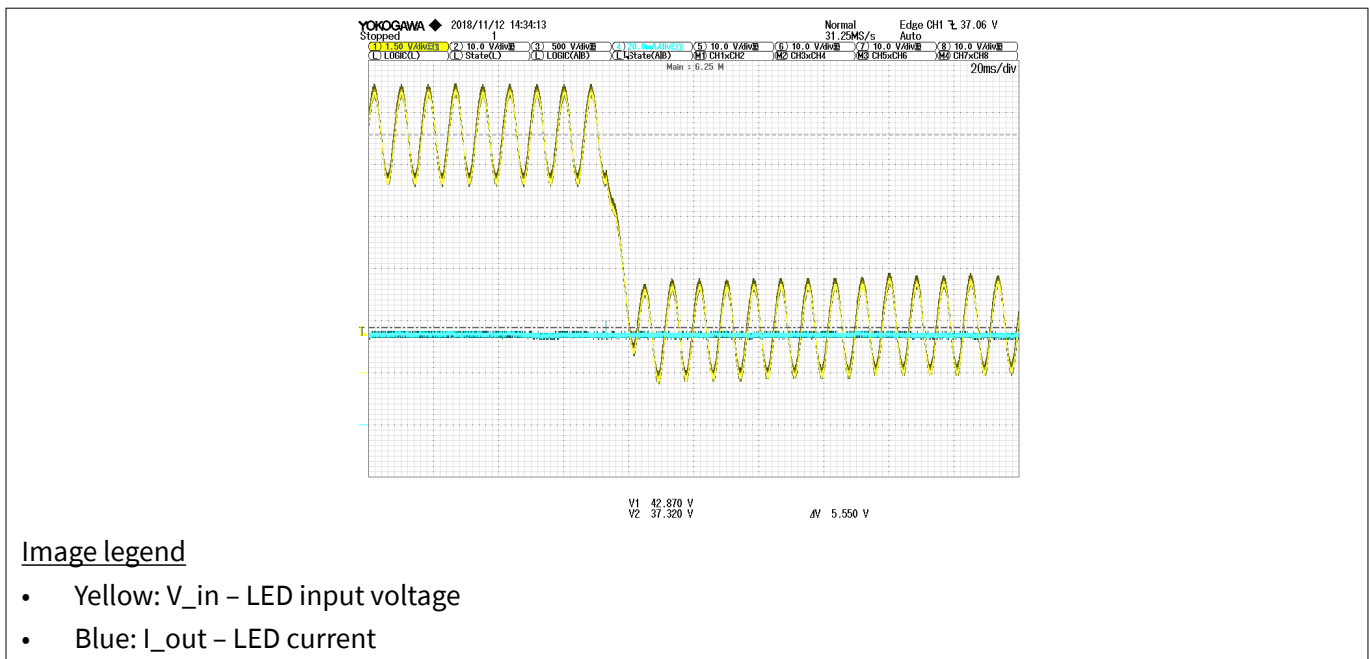

Figure 20 BCR601 short of two LEDs (14 to 12 LEDs)

Figure 20 shows a screenshot of a sudden short of two LEDs.

4 Test results

4.5.3 Overtemperature protection OTP

The OTP circuit protects the IC by reducing the target LED current to one-third.

OTP protects the device from damage in case of high ambient temperature. Activation temperature is higher than deactivation temperature, hence there is a hysteresis of greater than 20°C. OTP is independent of the grade and type of MFIO dimming.

Figure 21 shows the activation of the OTP protection in a system with 10 LEDs at 145°C. As a result of the drop of power consumption the Flyback controller of the primary side also switches its operating mode to a low power burst mode. This behavior of the primary side causes the change of the shape of the V_{IN+} signal from sinusoidal to saw-tooth. V_{DRAIN} shows remains of the AC-line signal.

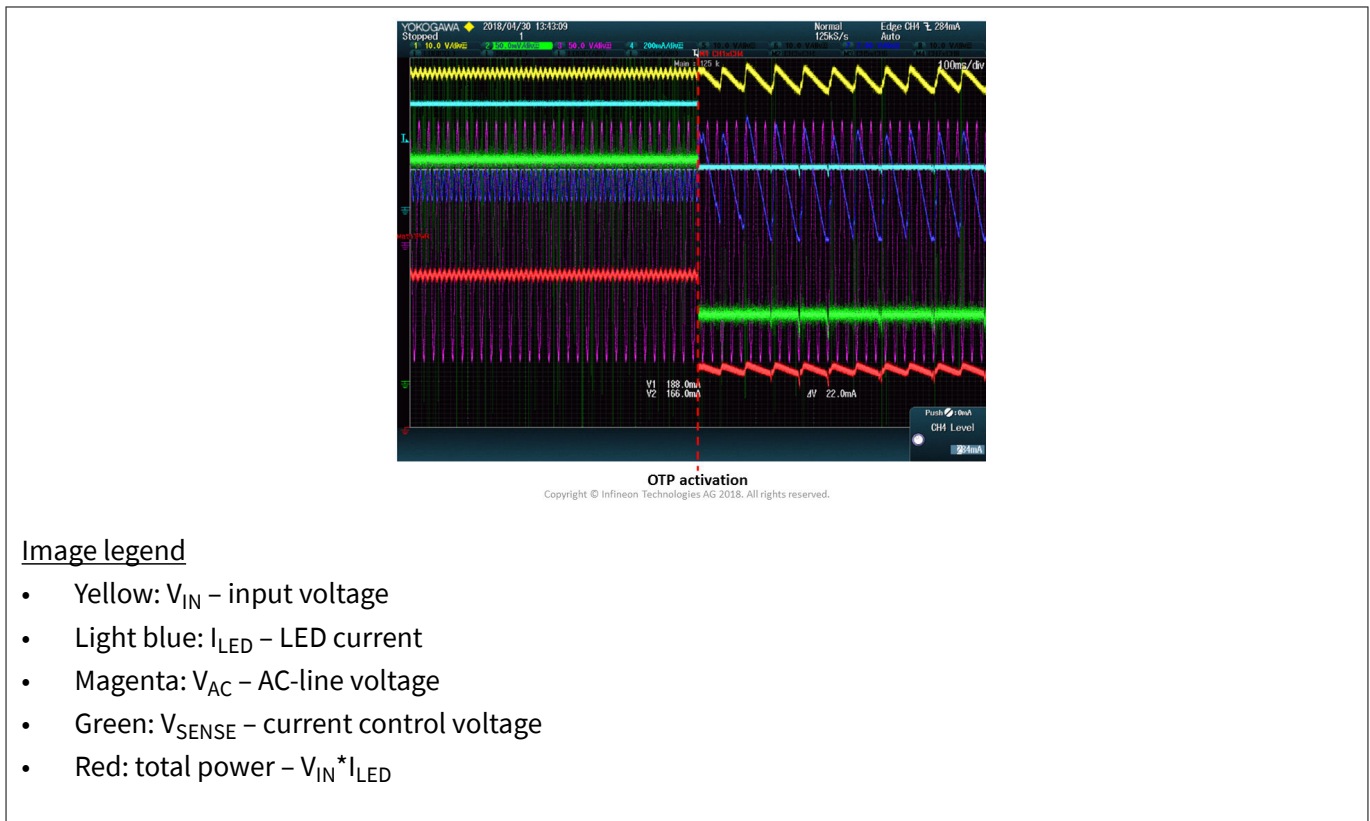

Image legend

- Yellow: V_{IN} – input voltage
- Light blue: I_{LED} – LED current
- Magenta: V_{AC} – AC-line voltage
- Green: V_{SENSE} – current control voltage
- Red: total power – $V_{IN} * I_{LED}$

Figure 21 **OTP activation at 10 LED, 145°C**

4.5.4 Over-Voltage Protection (OVP)

OVP protects the circuit by a fast overruling of the voltage feedback loop.

Figure 22 shows a circuit in which OVP was configured to a level of 47 V. The standard set-point of the input voltage V_{IN+} is ~45 V. Plug-in of three additional LEDs adds a required offset to the input voltage of ~9.6 V. So the new input voltage the controller of the voltage loop thrives for is ~54.6 V. This is above the configured OVP level. Starting from the plug-in of three additional LEDs:

- The input voltage shows operation of the primary-side Flyback controller in burst mode. The input voltage is increased up to the threshold of the OVP. Due to the fast demand reduction of the OVP, the primary side switches to burst mode.
- Current loop loses proper control and just follows the input voltage caused by a too low input voltage limited by trigger value of the OVP
- The input of the voltage controller V_{DROP} and $V_{collector}$ become unstable the same way as the target current

Figure 22 **Trigger of OVP by adding three additional LEDs to the circuit**

4 Test results

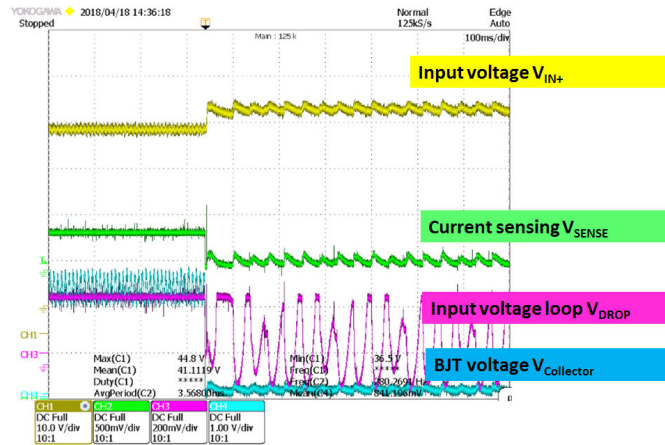

4.6 Thermal tests

This section describes the thermal stress of the BCR601 demonstrator design and the power loss over the transistor.

The power dissipation at the transistor is limited by the thermal resistance R_{thJA} of the power transistor. In the reference design due to the cooling area of the power MOSFET R_{thJA} is calculated to 70 W/K. With an ambient temperature of 20°C and a maximum accepted temperature the maximum power dissipation is 1 W. Using a TO-220 transistor package and a R_{thJA} of 40 K/W up to 1.75 W, in combination with external cooling, a dissipation of up to 2 W is feasible.

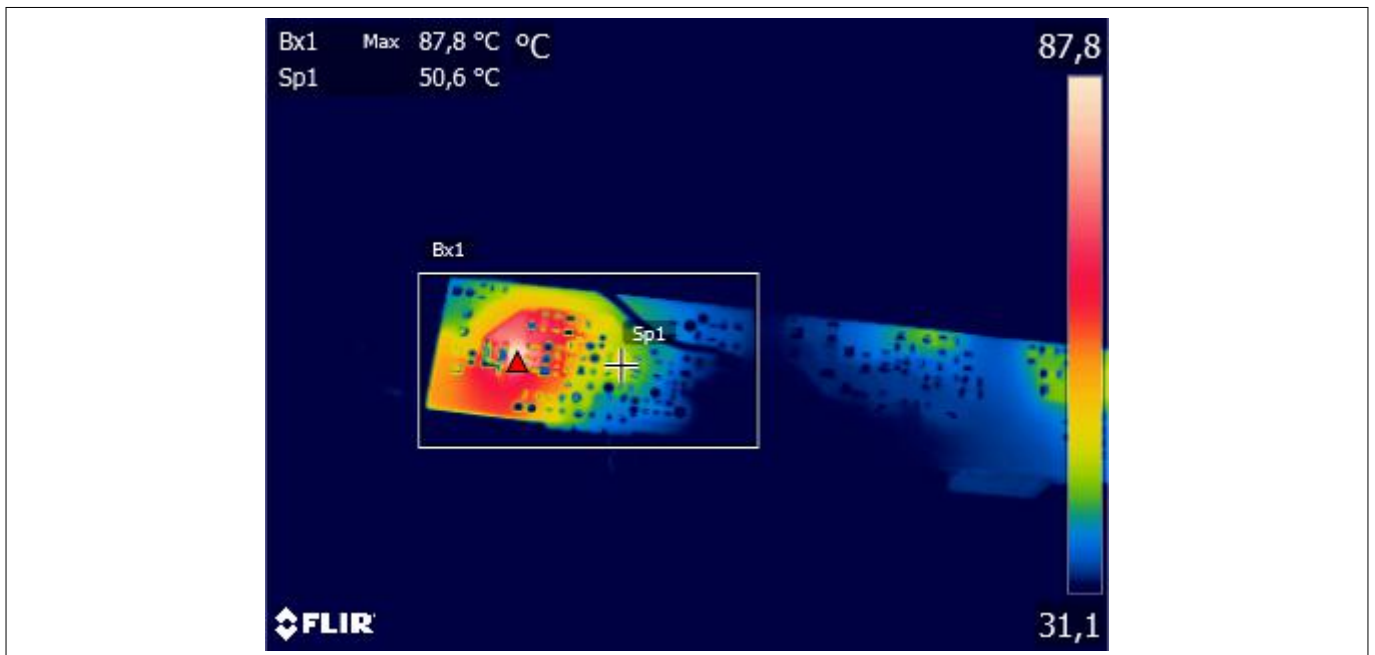

Figure 23 Thermal stress in case of the BCR reference design at 500 mA

Figure 23 shows the thermal stress of the BCR601 reference design under stable conditions. Stable conditions means the thermal flow is settled and no further temperature increase occurs.

The maximum heat dissipation is located at the BCP716N MOSFET. The power loss over the transistor is $P_{trans} = (V_{DRAIN, mean} - V_{SENSE}) * I_{LED} = (2.38 V - 400 mV) * 500 mA = 990 mW$. The BSP716N MOSFET reaches an absolute maximum of 87.8°C. At the same time the temperature of BCR601 remains at 50.6°C.

Figure 24 shows the stable operating condition of BCR601 with BSP716N. The device is operated driving 14 LEDs.

4 Test results

Figure 25 shows the system at all kind of dimming conditions over the whole range from 0 V to 4.0 V MFIO voltage. The power loss over the transistor has its maximum at no dimming conditions. The smaller the LED current, the smaller the power loss over the transistor.

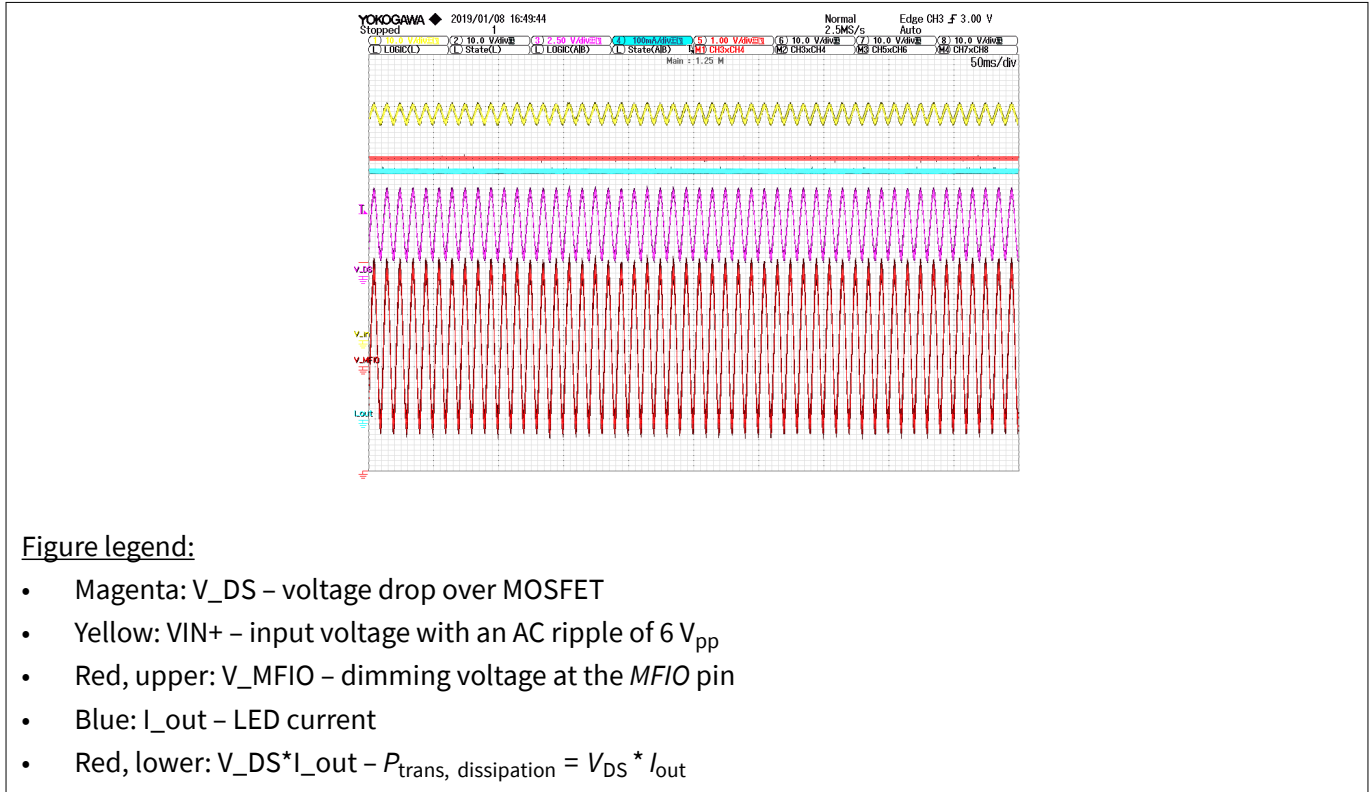

Figure legend:

- Magenta: V_DS – voltage drop over MOSFET
- Yellow: VIN+ – input voltage with an AC ripple of 6 V_{pp}
- Red, upper: V_MFIO – dimming voltage at the MFIO pin
- Blue: I_out – LED current
- Red, lower: V_DS * I_out – P_{trans, dissipation} = V_{DS} * I_{out}

Figure 24 Constant dimming conditions

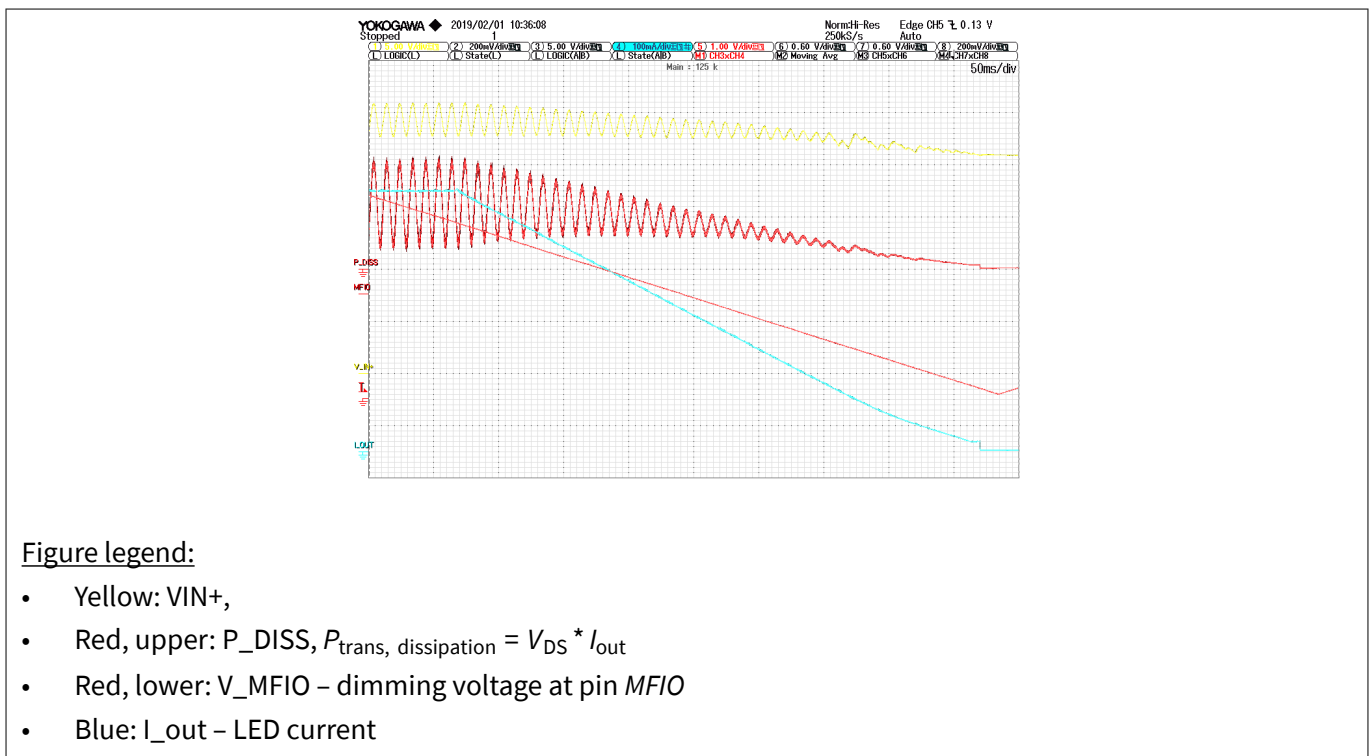

Figure legend:

- Yellow: VIN+,
- Red, upper: P_DISS, P_{trans, dissipation} = V_{DS} * I_{out}
- Red, lower: V_MFIO – dimming voltage at pin MFIO
- Blue: I_out – LED current

Figure 25 Power loss over transistor – full dimming range

4 Test results

Figure 25 shows the power dissipation at the MOSFET under variable dimming conditions. Lowest power dissipation is supported by the active headroom control. This reduces the input voltage following the lower forward voltage of the LEDs at lower LED current. Additionally, due to a lower AC-line ripple the voltage drop over the transistor is reduced at higher dimming conditions.

4.6.1 Option TO-220 package

This section describes thermal stress in case of a TO-220 package for the power transistor.

Figure 26 shows a BCR601 reference design operated with an IRFB3607 power MOSFET. The system is configured to 500 mA undimmed current. IRFB3607 has a TO-220 package. Due to the low thermal resistance junction-to-ambient $R_{\Theta JA}$ of 40 °C/W BCR601 systems higher than 500 mA target current are possible.

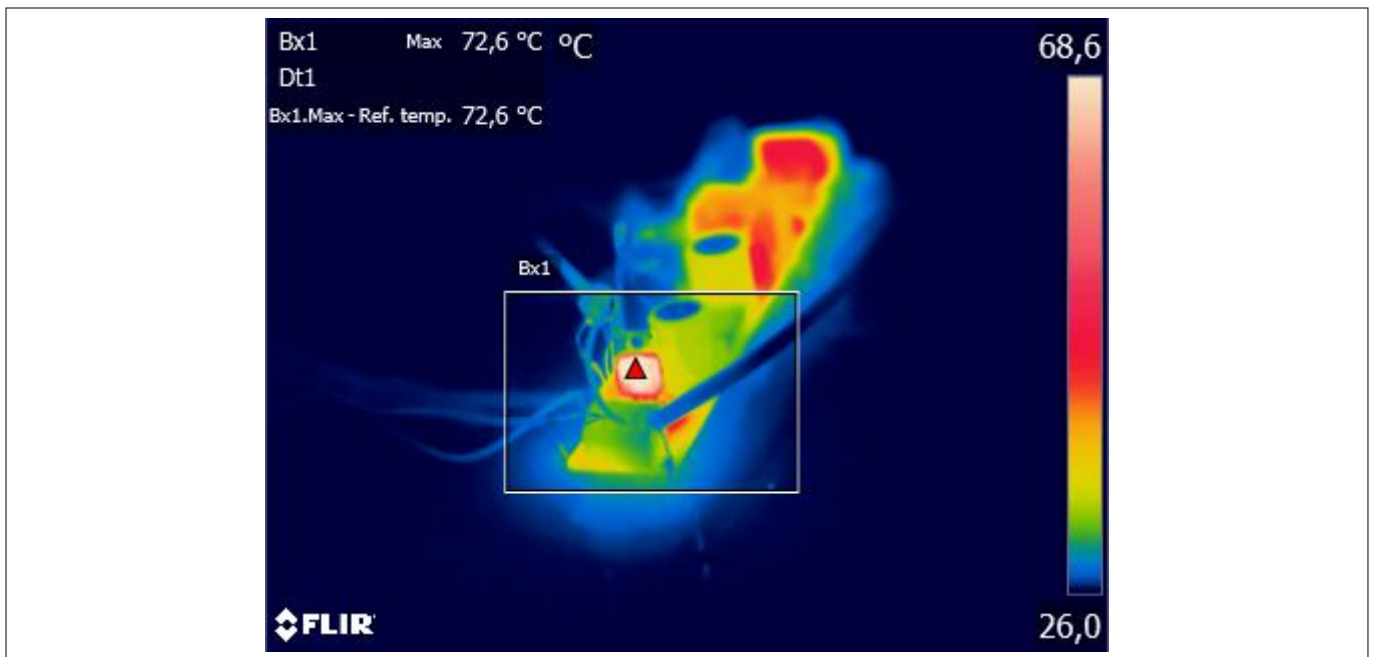

Figure 26 Maximum temperature of the TO-220 package at 500 mA

4.6.2 Option DPAK (TO-252) package

This section describes thermal stress in case of a DPAK (TO-252) package for the power transistor.

Figure 27 shows a BCR601 reference design operated with an IRFR120N power MOSFET. The system is configured to 500 mA undimmed current. IRFR120N has a TO-220 package. Due to the low thermal resistance junction-to-ambient $R_{\Theta JA}$ of 50°C/W BCR601 systems higher than 500 mA target current are possible.

4 Test results

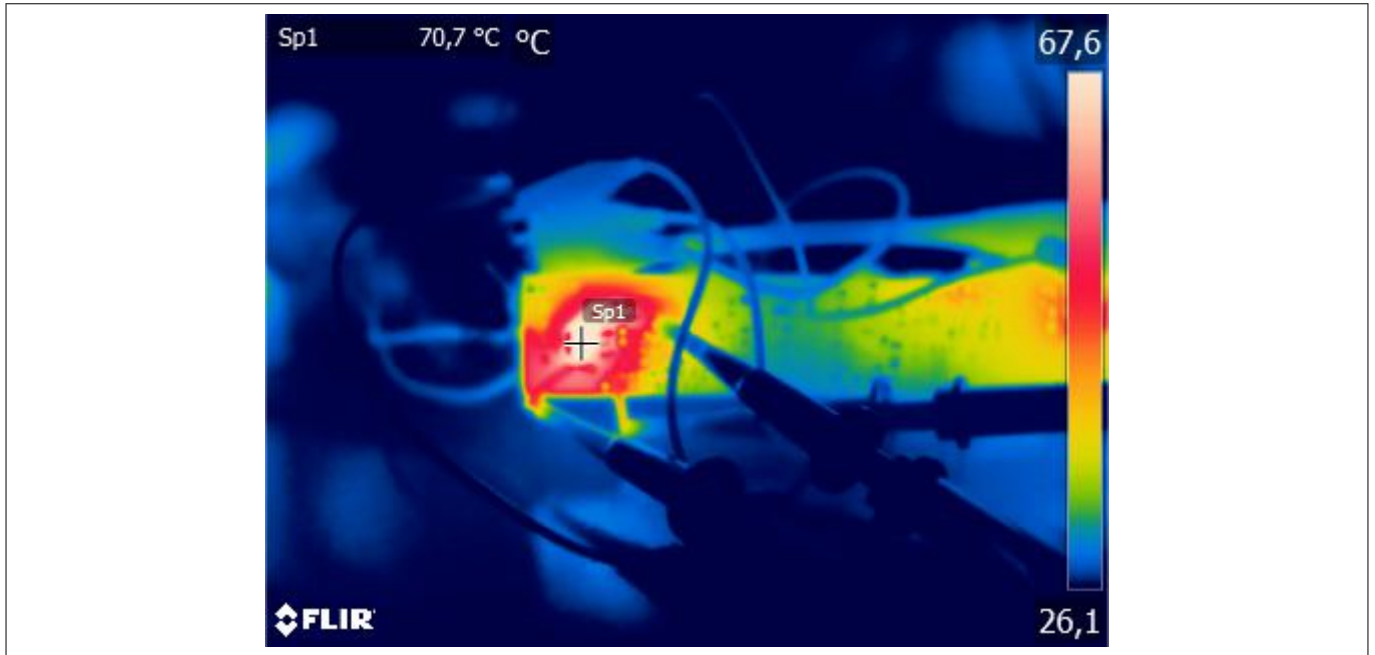

Figure 27 Maximum temperature DPAK package at 500 mA

4.7 Efficiency and harmonics

This section describes measurement results of efficiency and harmonics of a BCR601 system.

4.7.1 Efficiency

Figure 28 shows the efficiency versus dimming of a BCR601 system. Due to the feedback voltage control efficiency is kept at a high level over a wide range of dimming levels.

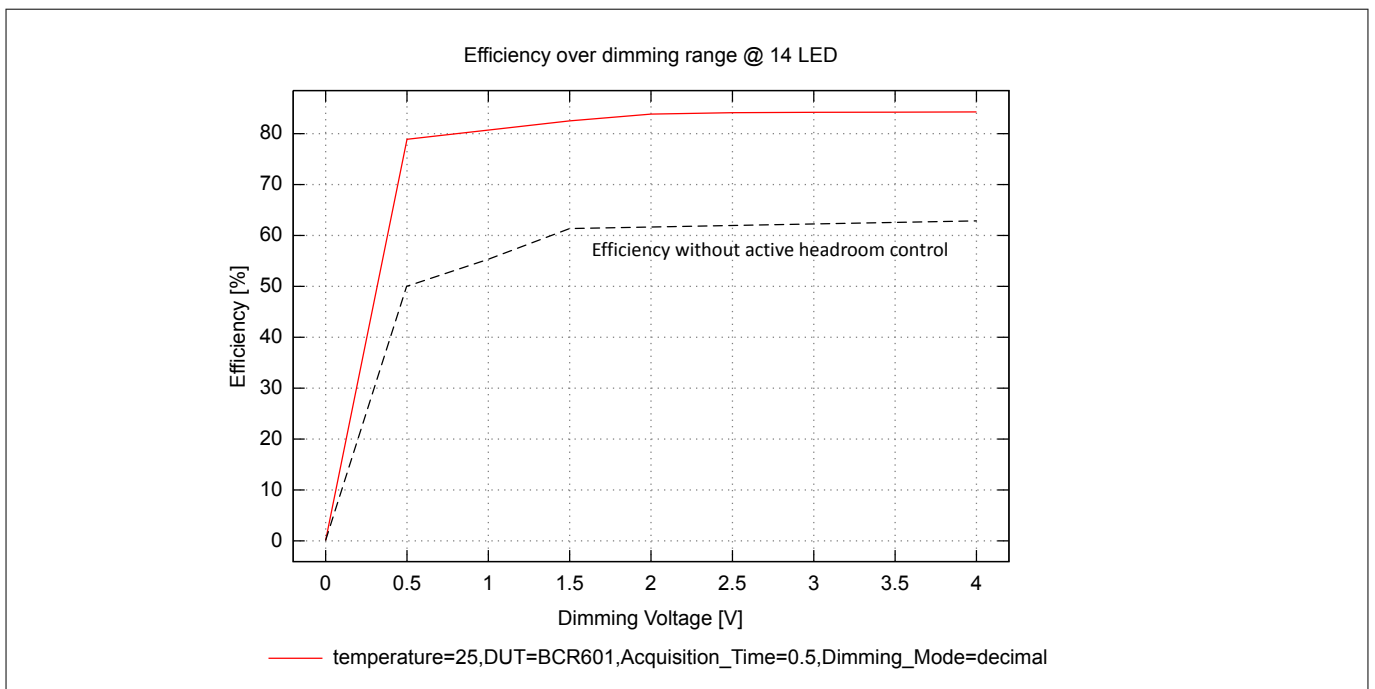

Figure 28 Efficiency over dimming voltage of a 14 LEDs BCR601 system

Figure 29 gives an overview about the system efficiency of a BCR601 system.

4 Test results

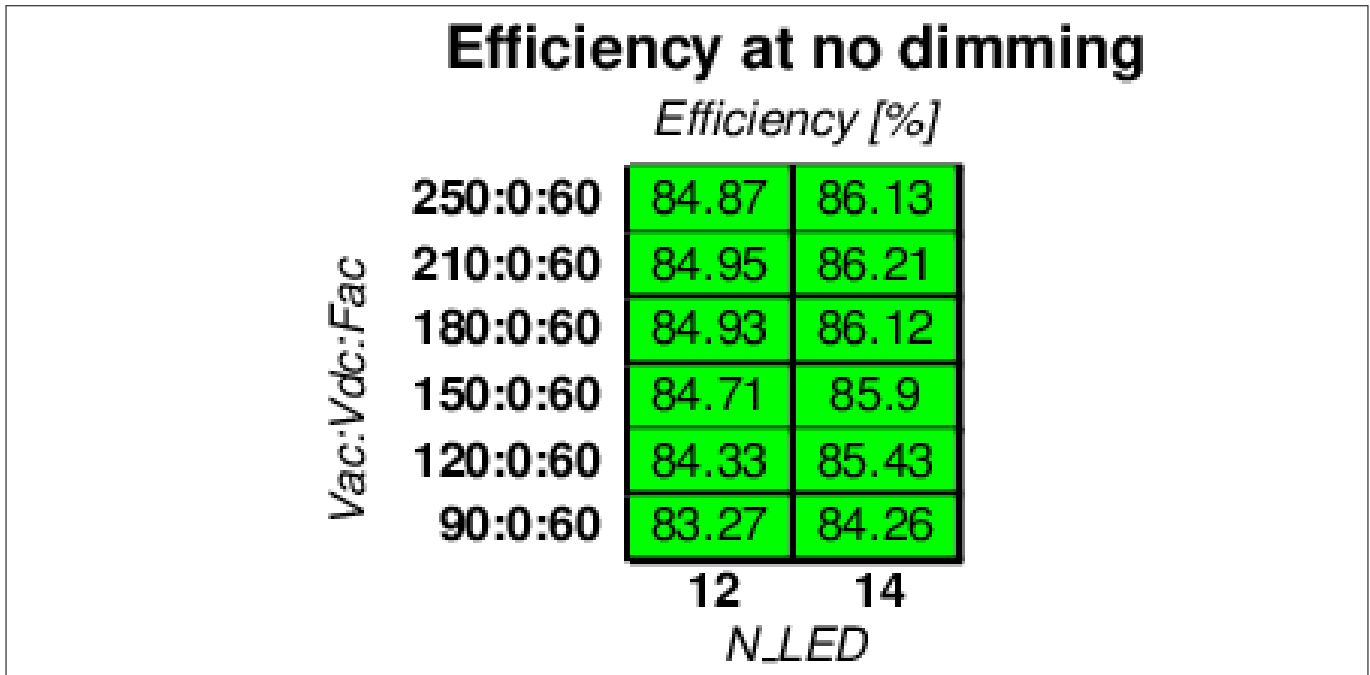

Figure 29 Efficiency of the BCR601 XDPL8218 system at various AC input levels

4.7.2 Harmonics and power factor

These are harmonics of the frequency of the AC supply.

Power factor

Measured power factor of a 14-LED OSLO Square was 0.9949.

Harmonics

The measured total harmonic distortion (THD) of the system was 2.325%.

Figure 30 shows the harmonics of a BCR601 system DC supplied by XDPL8218 driving a 14-LED OSLO Square at 500 mA.

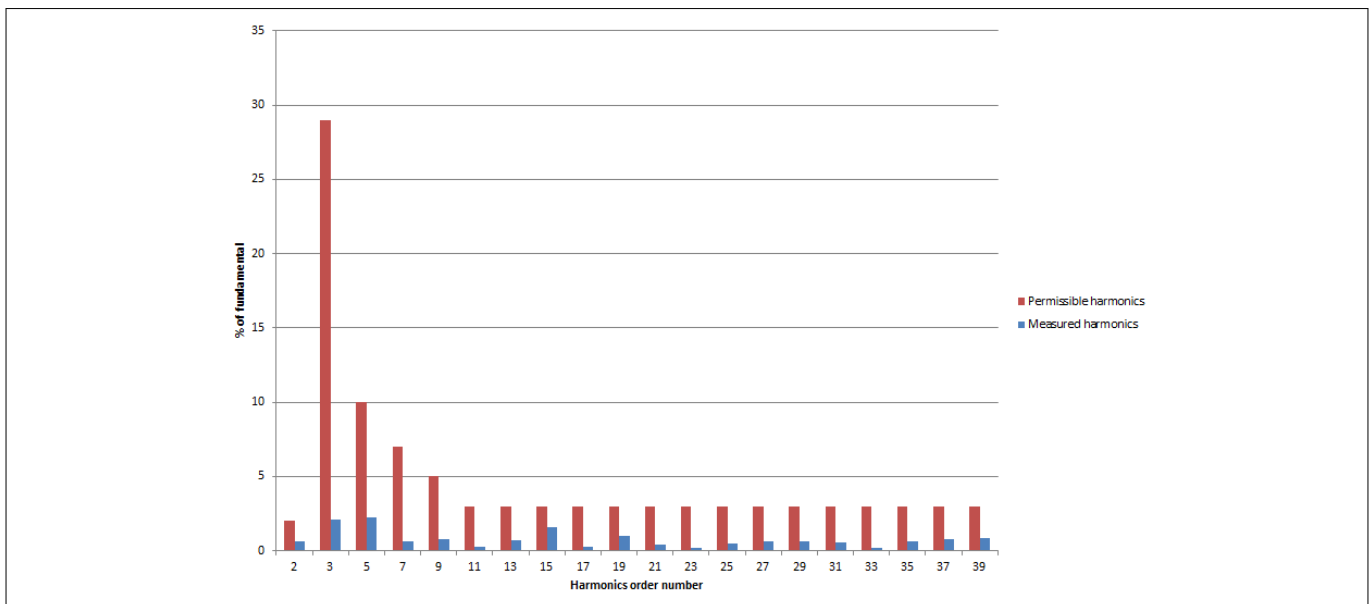

Figure 30 Line harmonics according to IEC61000-3-2

5 Bill of Materials (BOM)

5 Bill of Materials (BOM)

This section lists the material required for full equipment of a BCR601 demonstration board.

Table 4 BOM

Designator	Value	Footprint	Description	Manufacturer	Manufacturer part number
C1	N/A				
C2	150nF	CAPC3216X125N-0	Chip Monolithic Ceramic Capacitor	Kemet	C1206J154K1RA CAUTO
C4	1nF	CAPC2013X70N	Chip Monolithic Ceramic Capacitor	Kemet	C0805C102K3RA CTU
C5	100n	CAPC2013X145N-2	Multilayer Ceramic Chip Capacitor	TDK	C2012X7R2A104 K125AA
C6	N/A				12061C393KAT2 A
C7	100n	CAPC3216X70N	Cap-1206-100n/100V/0.1/X7R	AVX	12061C104KAZ2 A
C8	100n	CAPC3216X16N	Cap-1206-100n/100V/0.1/X7R	AVX	12061C104K4Z2 A
C10	N/A				
C14	N/A				
C15	100nF	CAPC1608X90N	Surface Mount Ceramic Capacitor Automotive Grade	AVX	06035C104K4Z2 A
C21	2.2uF	CAPC3216X180N	Chip Monolithic Ceramic Capacitor	muRata	GRM31CR72A225 KA73
D15	15V	SODFL1608X70N	Zener Voltage Regulator	ON Semiconductor	SZMM5Z15VT1G
J1	691309310006	691309310006	WR-TBL Serie 3093 - 3.81 mm Horizontal Reserved PCB Header, 06p	Wurth Elektronik	691309310006
J2	691418320004	691418320004	WR-TBL Serie 4183 - 3.81 mm 45° Entry Screwless, 4p	Wurth Elektronik	691418320004

5 Bill of Materials (BOM)

Table 4 BOM (continued)

Designator	Value	Footprint	Description	Manufacturer	Manufacturer part number
JC2	61300211821	61300211821	Through-Hole Micro Socket, 2.54mm pitch, 2 pin, Vertical, Single Row	Würth	61300211821
JC6	61300211821	61300211821	Through-Hole Micro Socket, 2.54mm pitch, 2 pin, Vertical, Single Row	Würth	61300211821
JP1	Jumper Wire 17,5+3,5, dia 0.9	JP-THT-1.00_2.20_17.5_0.80-2P	Jumperwire, max. 0.9dia, length 17,5+3,5	Manufacturer	
JP2	Jumper Wire 5.08+3.5, dia 0.9	JP-THT-1.00_2.20_5_0.80-2P	Jumperwire, max. 0.9dia, length 5.08+3.5	Manufacturer	
JR5	61300211821	61300211821	Through-Hole Micro Socket, 2.54mm pitch, 2 pin, Vertical, Single Row	Würth	61300211821
JR6	61300211821	61300211821	Through-Hole Micro Socket, 2.54mm pitch, 2 pin, Vertical, Single Row	Würth	61300211821
JR8	61300211821	61300211821	Through-Hole Micro Socket, 2.54mm pitch, 2 pin, Vertical, Single Row	Würth	61300211821
JR15	61300211821	61300211821	Through-Hole Micro Socket, 2.54mm pitch, 2 pin, Vertical, Single Row	Würth	61300211821
JR16	61300211821	61300211821	Through-Hole Micro Socket, 2.54mm pitch, 2 pin, Vertical, Single Row	Würth	61300211821
Q1	N/A				

5 Bill of Materials (BOM)

Table 4 BOM (continued)

Designator	Value	Footprint	Description	Manufacturer	Manufacturer part number
Q2	BSP716N	SOT230P700X18 0-4N-4	N-Channel Logic Level Enhancement Mode Field Effect Transistor	Infineon	BSP716N H6327
Q3	N/A				
Qx	also BJT	TO-220-THT-MJE15034	Complementary Silicon Plastic NPN Power Transistor	ON Semiconductor	MJE15034G
R2	0R	RESC2113X50N	0R/150V/20mOhm	Vishay	CRCW08050000Z0EA
R3	3.6k	RESC2113X50N	3.6k/150V/1%	Vishay	CRCW08053K60FKEA
R4	160k	RESC2113X50N	160k/150V/1%	Vishay	CRCW0805160KFKEA
R5	20R	RESC3216X60N	20R/200V/1%	Vishay	CRCW120620R0FKEA
R6	430k	RESC2113X50N	430k/150V/1%	Vishay	CRCW0805430KFKEA
R8	8.2k	RESC1609X50N	Standard Thick Film Chip Resistor	Vishay	CRCW06038K20FKEA
R9	1k	RESC1609X50N	Standard Thick Film Chip Resistor	Vishay	CRCW06031K00FKEA
R11	1.3R	RESC3216X60N	1.3R/200V/1%	Vishay	CRCW12061R30FKEA
R12	2.2R	RESC3216X60N	2.2R/200V/1%	Vishay	CRCW12062R20FKEA
R13	N/A				
R14	N/A				
R15	15k	RESC1609X50N	Standard Thick Film Chip Resistor	Vishay	CRCW060315K0FKEA
R16	0R	RESC2113X50N	0R/150V/20mOhm	Vishay	CRCW08050000Z0EA
R20	5.1k	RESC2113X50N	Standard Thick Film Chip Resistor	Panasonic	ERJP06F5101V

5 Bill of Materials (BOM)

Table 4 **BOM (continued)**

Designator	Value	Footprint	Description	Manufacturer	Manufacturer part number
Rset	470k	RESC2113X50N	Standard Thick Film Chip Resistor	Vishay	CRCW0805470KF K
U1	BCR601	SOIC127P600X17 5-8N-10-V	BCR601, IC, SOIC, 8pin,	Infineon	BCR601
X2..X26	N/A	TPCW100D120H 460B	Black bead terminal assembly 1.02mm hole	Vero Technologies	20-2137

6 Related links and support material

6 Related links and support material

A selection of useful internet shortcuts.

- BCR601 documents
 - <http://www.infineon.com/BCR601>
- Power Management selection guide
 - <http://www.infineon.com/powermanagement-selectionguide>
- Search videos
 - <http://www.infineon.com/mediacenter>
- Where to buy
 - <http://www.infineon.com/wheretobuy>
- Cross reference search
 - <http://www.infineon.com/crossreference>
- Evaluation boards
 - <http://www.infineon.com/evaluationboards>
- Package information
 - <http://www.infineon.com/packages>
- Contact and support
 - <http://www.infineon.com/support>

Trademarks

All referenced product or service names and trademarks are the property of their respective owners.

Edition 2019-02-25

Published by

Infineon Technologies AG

81726 Munich, Germany

© 2019 Infineon Technologies AG

All Rights Reserved.

Do you have a question about any aspect of this document?

Email: erratum@infineon.com

Document reference

IFX-tbm1525447909333

IMPORTANT NOTICE

The information contained in this application note is given as a hint for the implementation of the product only and shall in no event be regarded as a description or warranty of a certain functionality, condition or quality of the product. Before implementation of the product, the recipient of this application note must verify any function and other technical information given herein in the real application. Infineon Technologies hereby disclaims any and all warranties and liabilities of any kind (including without limitation warranties of non-infringement of intellectual property rights of any third party) with respect to any and all information given in this application note.

The data contained in this document is exclusively intended for technically trained staff. It is the responsibility of customer's technical departments to evaluate the suitability of the product for the intended application and the completeness of the product information given in this document with respect to such application.

WARNINGS

Due to technical requirements products may contain dangerous substances. For information on the types in question please contact your nearest Infineon Technologies office.

Except as otherwise explicitly approved by Infineon Technologies in a written document signed by authorized representatives of Infineon Technologies, Infineon Technologies' products may not be used in any applications where a failure of the product or any consequences of the use thereof can reasonably be expected to result in personal injury

X-ON Electronics

Largest Supplier of Electrical and Electronic Components

Click to view similar products for [LED Lighting Development Tools](#) category:

Click to view products by [Infineon](#) manufacturer:

Other Similar products are found below :

[MIC2870YFT EV](#) [TDGL014](#) [ISL97682IRTZEVALZ](#) [EA6358NH](#) [TPS92315EVM-516](#) [STEVAL-LLL006V1](#) [IS31LT3948-GRLS4-EB](#)
[PIM526](#) [PIM527](#) [MAX6946EVKIT+](#) [MAX20070EVKIT#](#) [MAX20090BEVKIT#](#) [PIM498](#) [AP8800EV1](#) [ZXLD1370/1EV4](#) [1216.1013](#) [1270](#)
[1271.2004](#) [1272.1030](#) [1273.1010](#) [1278.1010](#) [1279.1002](#) [1279.1001](#) [1282.1000](#) [1293.1900](#) [1293.1800](#) [1293.1700](#) [1293.1500](#) [1293.1100](#)
[1282.1400](#) [1282.1100](#) [1293.1200](#) [1282.1200](#) [1293.1000](#) [1282.6000](#) [1296.2012](#) [MIKROE-2520](#) [1721](#) [1762](#) [PIR-GEVB](#) [TPS61161EVM-243](#)
[STEVAL-ILL056V1](#) [ADM00767](#) [STEVAL-ILL080V1](#) [DC1224A](#) [DC1160A](#) [DC1039A-A](#) [DC1816B](#) [DC1511A-A](#) [DC1274A](#)