

ITS42k5D-LD-F

Dual Channel High-Side PMOS Power Switch with
Integrated Freewheeling Diodes

Demoboard User's Guide

Rev. 0.1, 2015-05-29

1 Introduction

The ITS42k5D-LD-F demo board can be used to easily evaluate the dual channel high-side smart switch in the very small and thermally optimized PG-TSON-10 package. The ITS42k5D-LD-F demo board is fully equipped with external components as well as the device.

This demo board user's guide contains all necessary information for using of the this board to evaluate the ITS42k5D-LD-F.

Table 1 Device Overview

Type	Number of Channels	Output current	Protection Features	Package	Ordering Information
ITS42k5D-LD-F	Dual channel device	250 mA per channel	Short-circuit, Overtemperature Undervoltage-Lockout, Open Load Detection	PG-TSON-10	Device OPN: DEMOBOARDITS42k5DTOBO1 Name: DEMOBOARD ITS42k5D SP No.: SP001213116

1.1 General Description

The ITS42k5D-LD-F is a dual channel high-side PMOS power switch. The device is equipped with integrated protection and diagnostic features.

The diagnosis can be read out from two separate open drain outputs in order to indicate overload, short circuit, open load and overtemperature conditions. The device controls the respective channel one or two by the two separate input pins i.e. IN1 and IN2. When both inputs are low the device is in OFF condition. Each channel of the device is able to drive loads up to 250mA.

The ITS42k5D-LD-F is capable of switching resistive, capacitive and inductive loads (e.g. sensor units, LEDs, relays, valves) in harsh industrial environments. An integrated freewheeling diode per channel enables driving of inductive loads as well as long wire lengths.

For more detailed information please refer to the datasheet and application notes for the device available on the Infineon website www.infineon.com.

1.2 ITS42k5D-LD-F Feature List

- Two channel power PMOS high-side switch
- Integrated freewheeling diodes
- Output Current Capacity: up to 250 mA per channel
- Wide operating voltage range: 4.5 V to 42 V
- Very low quiescent current in OFF state
- 3 V and 5 V compatible logic inputs
- Optimized EMC behavior
- Overload, short circuit, open load and overtemperature diagnosis
- ESD, short circuit, safe operation area and overtemperature protection
- Undervoltage lockout (UVLO)
- Green and robust product (RoHS compliant)

1.3 Block Diagram

Figure 1 shows the block diagram of the ITS42k5D-LD-F.

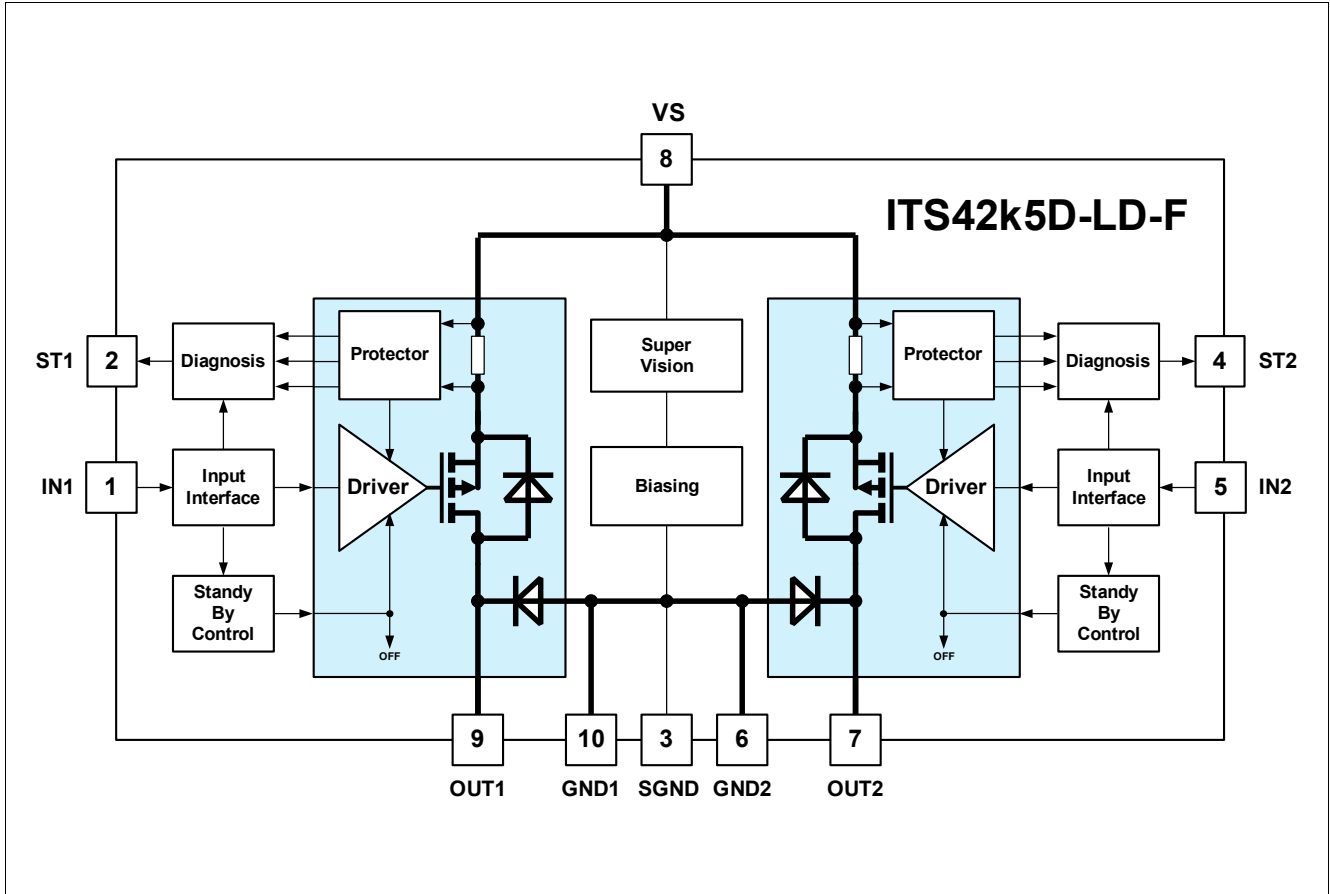

Figure 1 Block Diagram of the ITS42k5D-LD-F

1.4 Pin Configuration

Figure 2 shows the pin assignment of the ITS42k5D-LD-F.

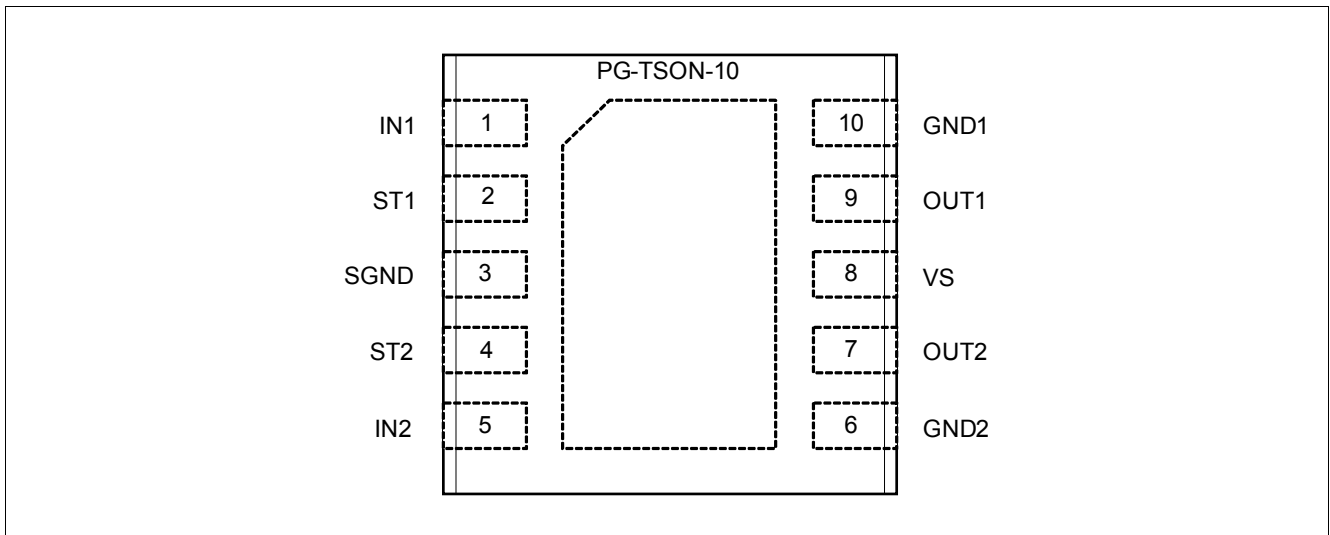

Figure 2 Pin-Out of the ITS42k5D-LD-F

1.5 Pin Definition and Functions

Table 2 Pin Definition

Pin	Symbol	Function
1	IN1	INPUT 1 ; Control input for channel 1, Active High
2	ST1	STATUS 1 ; Status flag for channel 1, Open Drain Output
3	SGND	SIGNAL GND ; connect to all GNDs and to exposed GND pad
4	ST2	STATUS 1 ; Status flag for channel 2, Open Drain Output
5	IN1	INPUT 2 ; Control Input for channel 2, Active High
6	GND2	Ground Channel 2 ; Connect to all GNDs and to exposed GND pad
7	OUT2	OUTPUT 2 ; Drain of the power-PMOS channel 2, power freewheeling diode to GND
8	VS	Supply Voltage ; Block to GND with a capacitor near the IC
9	OUT1	OUTPUT 1 ; Drain of the power-PMOS channel 1, power freewheeling diode to GND
10	GND1	Ground Channel 1 ; Connect to all GNDs and to exposed GND pad
Exposed Pad	–	Connect externally to all GNDs i.e. GND1, GND2 and SGND

2 Demo Board

Figure 3 shows a ITS42k5D-LD-F Demo board (PG-TSON-10) equipped with the device.

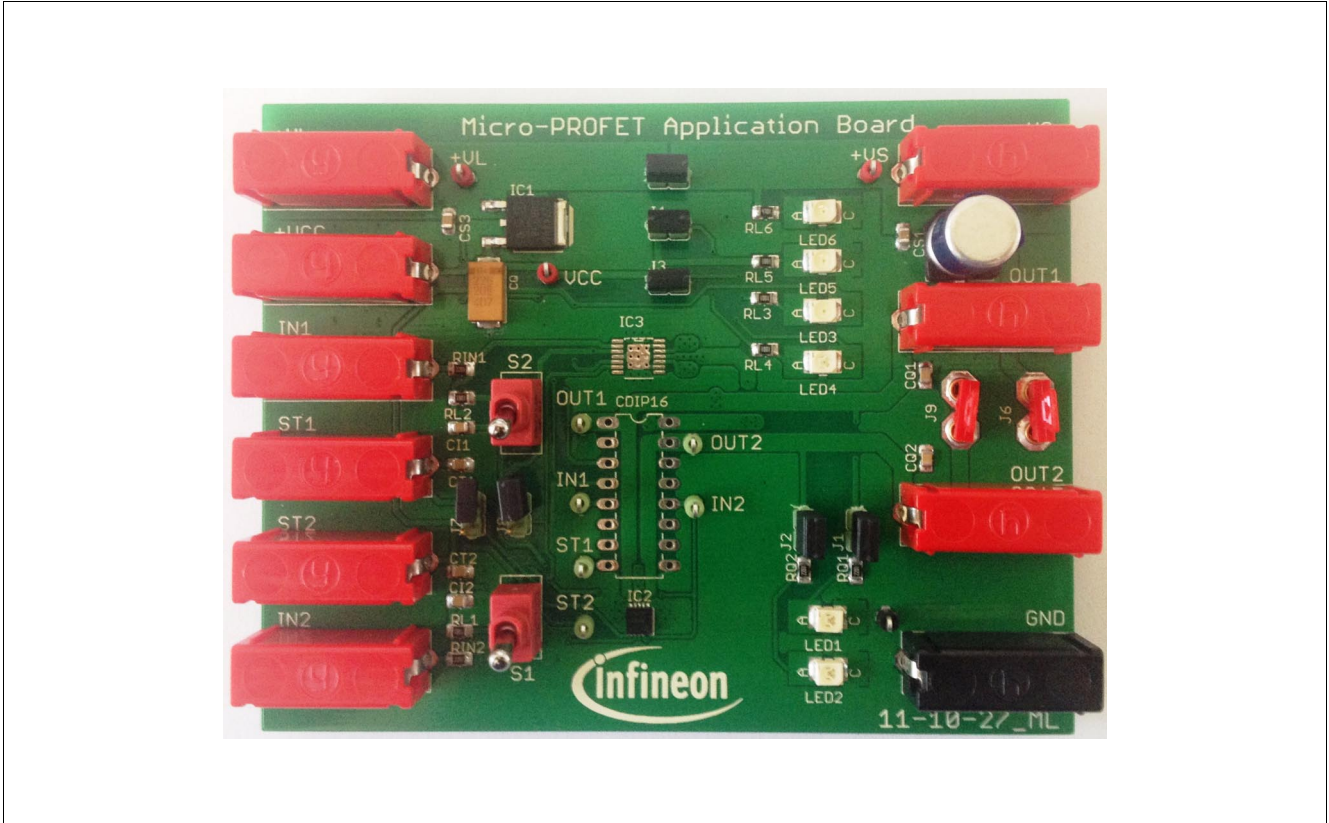

Figure 3 ITS42k5D-LD-F Demo Board (PG-TSON-10)

2.1 Operating Conditions

To avoid any electrical damage of the demo board, the maximum operating range defined in [Table 3](#) must be followed.

Table 3 Operating Range¹⁾

Parameter	Symbol	Limit Values		Unit	Note
		Min.	Max.		
Board Supply ²⁾	V_S	0	42	V	Power supply
Input Voltage	$V_{IN1,2}$	0	7	V	Control input voltage levels
Status Voltage	$V_{ST1,2}$	0	7	V	–
Ground	GND	0	0	V	System GND

1) The Demo Board operates at ambient temperature of 25°C

2) Functional input voltage range starts from 4.5 V to 42 V

2.2 Demo board Details

The ITS42k5D-LD-F demo board allows for easy evaluation of the device. The board comes equipped with the following devices:

- The ITS42k5D-LD-F i.e. the dual channel high-side PMOS power switch (DUT)
- 5V linear voltage regulator IFX25001TFV50 for an on board pull-up for status outputs and providing input voltage for IN1 and IN2 (via S2 and S1)
- Green LED, LED5 to indicate a 5V output from the IFX25001TFV50
- Green LED, LED6 to indicate external supply voltage availability
- Red LEDs, LED3 and LED4 for STATUS output indication in case of a fault condition
- Yellow LEDs, LED1 and LED2 to indicate the two outputs of the **ITS42k5D-LD-F**
- CDIP-16 Footprint for daughter board usage
- External components (e.g. resistors, capacitors etc.)

2.2.1 Jumper Settings

The jumper settings for the ITS42k5D-LD-F demo board are given in table 4:

Table 4 Jumper settings for demo board quick start

Jumper	Set	Open
J1	LED1 turns ON when OUT1 is High (Optional)	No indication when OUT1 is High
J2	LED2 turns ON when OUT2 is High (Optional)	No indication when OUT1 is High
J3	Provides pull up for Status pin 2 i.e. ST2, LED3 turns ON in case of fault condition	External pull up resistor between 5V rail and ST pin necessary
J4	Provides pull up for Status pin 1 i.e. ST1, LED4 turns ON in case of fault condition	External pull up resistor between 5V rail and ST pin necessary
J5	Input of linear voltage regulator supplied via +VS; Voltage on +VL not required	Input of linear voltage regulator supplied via +VL
J6	Enables external supply voltage at VSS pin of the device under test	Device not supplied
J7	Connects two status outputs ST1 and ST2. Connect if J9 is connected i.e. OUT1 and OUT2 are connected in parallel.	Separate fault indication per channel via ST1 and ST2

Table 4 Jumper settings for demo board quick start

Jumper	Set	Open
J8	Connects the two inputs IN1 and IN2 if a common gate control is required for both channels	IN1 and IN2 can be controlled individually for channel 1 and channel 2
J9	Connects OUT1 and OUT2 (parallel functionality)	Two separate outputs OUT1 and OUT2 can drive two separate loads

2.2.2 Test Points on the ITS42k5D-LD-F demo board

The various test points available on the ITS42k5D-LD-F demo board are given in table 5:

Table 5 Test point description for demo board quick start

Jumper	Set
LSP1	Test point for control input at channel 1 i.e. IN1
LSP2	Test point for status feedback for channel 1 i.e. ST1
LSP3	Test point for status feedback for channel 2 i.e. ST2
LSP4	Test point for control input at channel 2 i.e. IN2
LSP5	Test point for output of channel 1 i.e. OUT1
LSP6	Test point for output of channel 2 i.e. OUT2
LSP7	Test point for external voltage +VL
LSP8	Test point for output of linear voltage regulator IFX25001TFV50
LSP9	Test point for external supply voltage +VS
LSP10	Test point Ground

3 Schematic and Layout

3.1 Schematic

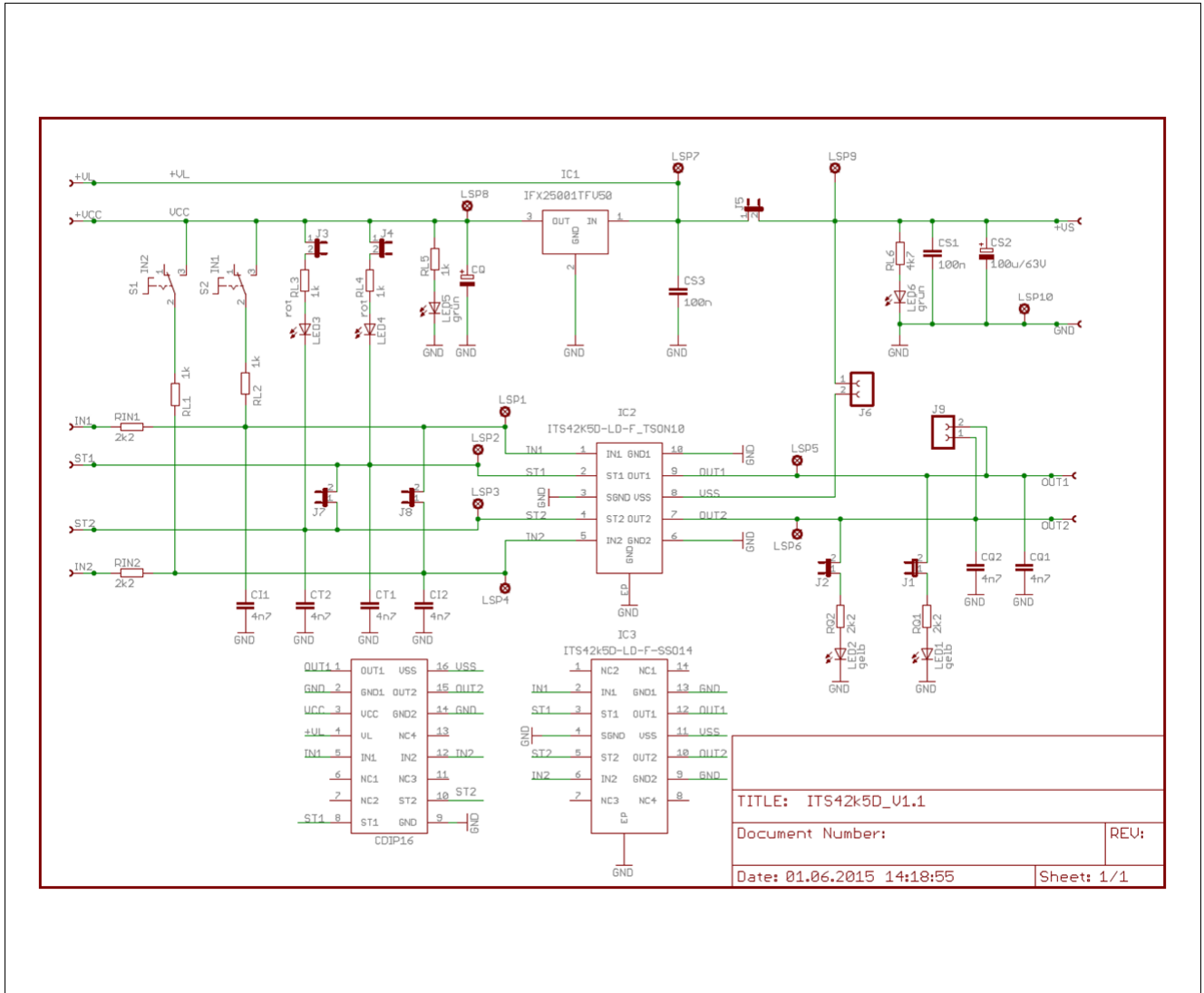

Figure 4 Schematic of ITS42k5D-LD-F Demo board (PG-TSO-10)

3.2 Layout

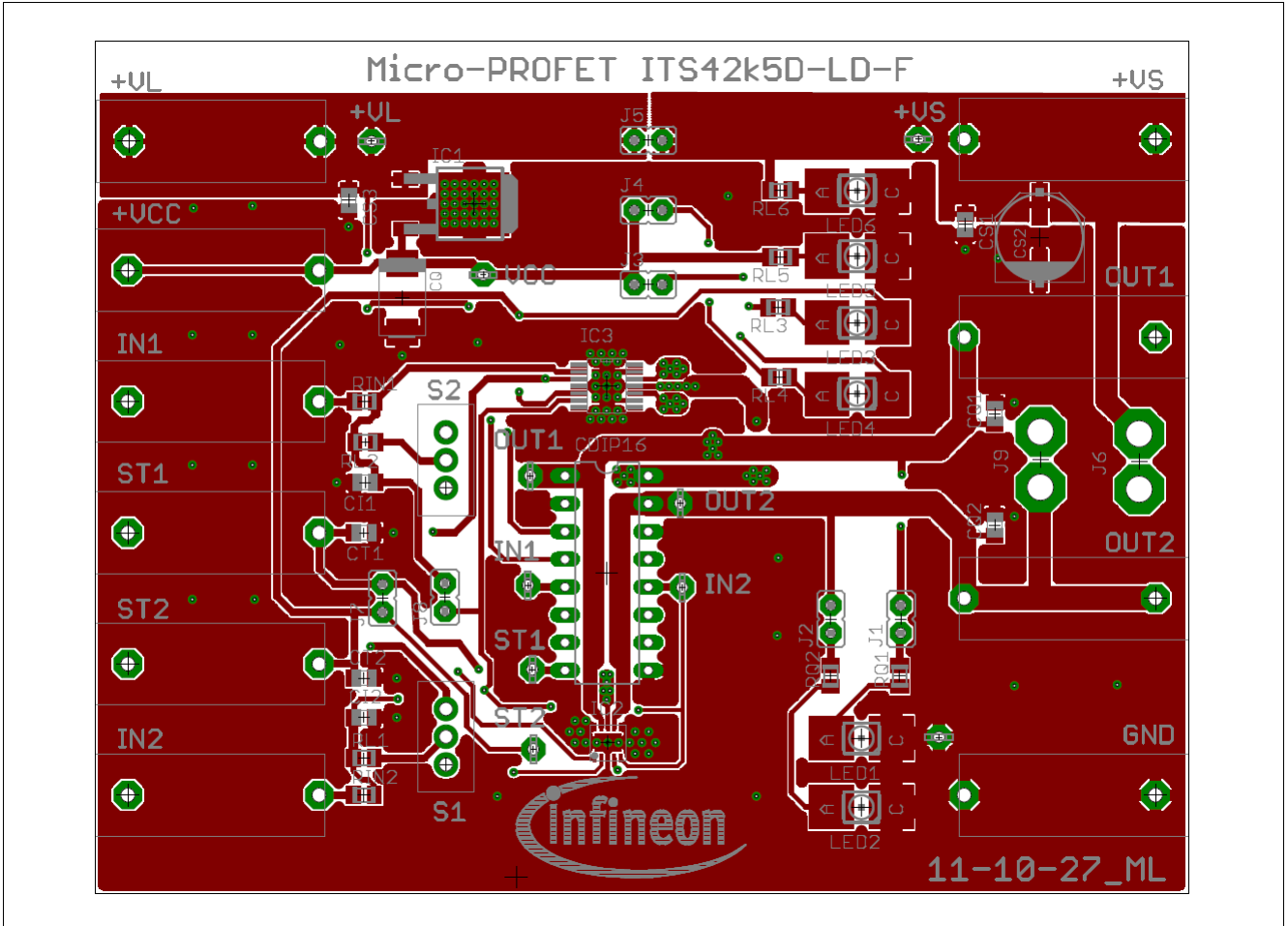

Figure 5 Top Layer of ITS42k5D-LD-F Demo board (PG-TSON-10)

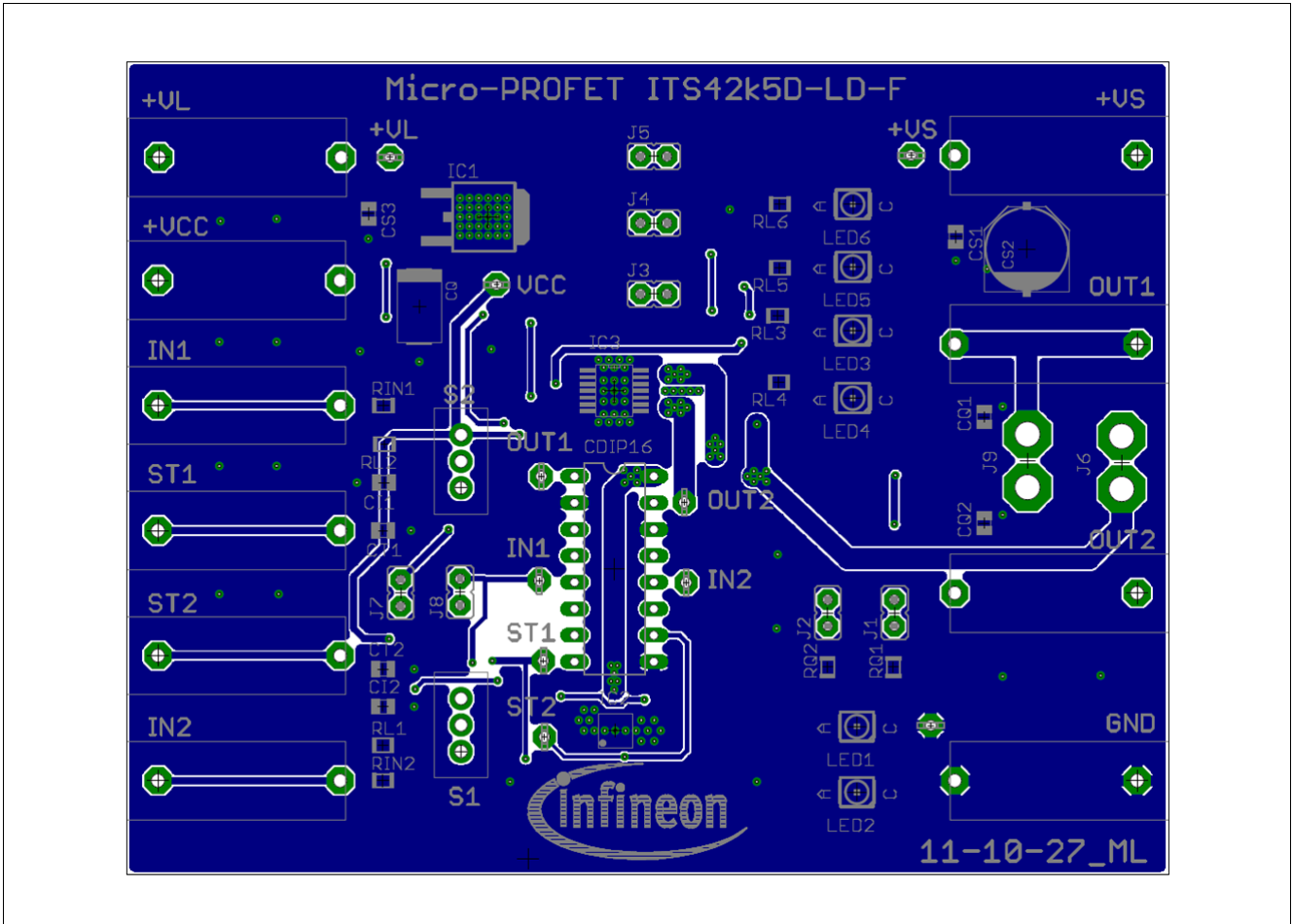

Figure 6 Bottom Layer of ITS42k5D-LD-F Demo board (PG-TSON-10)

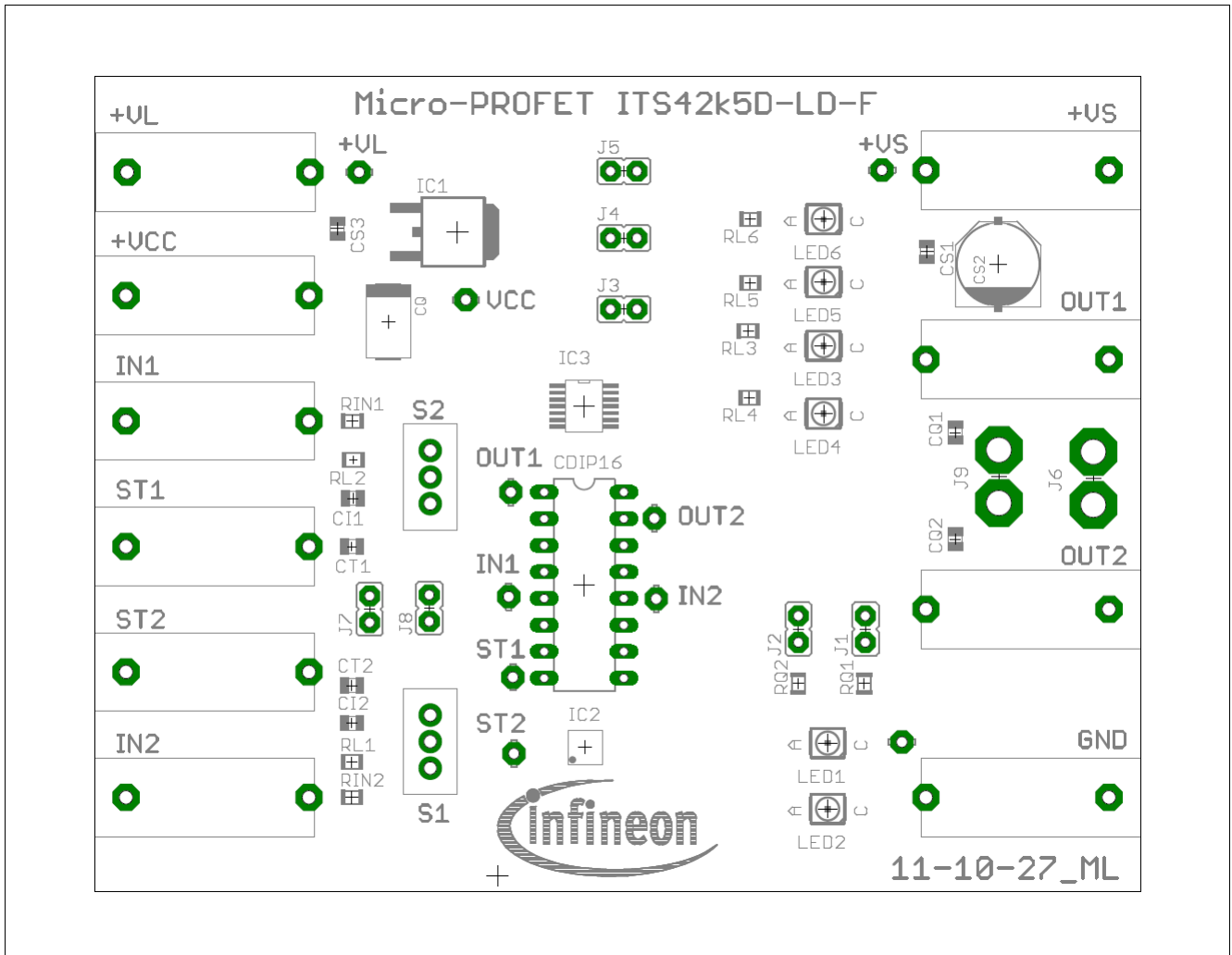

Figure 7 Top Layer components of ITS42k5D-LD-F Demo board (PG-TSON-10)

4 Bill of Materials

Table 6 Bill of Materials

Part Number	Value	Package	Part description as on the Board
BABU4MM	–	BANANENBUCH SE4MM	+VCC, +VL, +VS, GND, IN1, IN2, OUT1, OUT2, ST1, ST2
CPOL-EUSMCD	–	SMC_D	CQ
JP1E	–	JP1	J1, J2, J3, J4, J5, J7, J8
SB12-2	–	SB12-2	J6, J9
C-EUC0805	100 nF	C0805	CS1, CS3
CPOL-EUE	100 μ F/63 V	PANASONIC_E	CS2
R-EU_M0805	1 k Ω	M0805	RL1, RL2, RL3, RL4, RL5
R-EU_M0805	2.2 k Ω	M0805	RIN1, RIN2, RQ1, RQ2
R-EU_M0805	4.7 k Ω	M0805	RL6
C-EUC0805	4.7 nF	C0805	CI1, CI2, CQ1, CQ2, CT1, CT2
IFX25001TFV50	5V Linear Regulator	TO-252-3	IC1
2B11	IN1	ELEDIS_2B11	S2
2B11	IN2	ELEDIS_2B11	S1
ITS42k5D-LD-F	Dual Channel High-Side PMOS Power Switch with Integrated Freewheeling Diodes	TSON-10	IC2
LSP10	LSP10	LSP10	LSP1, LSP2, LSP3, LSP4, LSP5, LSP6, LSP7, LSP8, LSP9, LSP10
LEDP-LCC-2	Yellow LED	P-LCC-2	LED1, LED2
LEDP-LCC-2	Green LED	P-LCC-2	LED5, LED6
LEDP-LCC-2	Red LED	P-LCC-2	LED3, LED4

5 General Information

5.1 Restrictions

This demo board offers limited features allowing you to only evaluate and test the Infineon products. The demo board is not an end product (or finished appliance), nor is it intended or authorized by Infineon to be integrated into end products. You are not authorized to use the demo board or its design in any kind of productive system.

5.2 Additional Information

- For further information you may refer to <http://www.infineon.com/>

5.3 Revision History

Revision	Date	Changes
1.0	2015-05-29	Initial version

Edition 2015-05-29

**Published by
Infineon Technologies AG
81726 Munich, Germany**

**© 2015 Infineon Technologies AG
All Rights Reserved.**

LEGAL DISCLAIMER

THE INFORMATION GIVEN IN THIS APPLICATION NOTE IS GIVEN AS A HINT FOR THE IMPLEMENTATION OF THE INFINEON TECHNOLOGIES COMPONENT ONLY AND SHALL NOT BE REGARDED AS ANY DESCRIPTION OR WARRANTY OF A CERTAIN FUNCTIONALITY, CONDITION OR QUALITY OF THE INFINEON TECHNOLOGIES COMPONENT. THE RECIPIENT OF THIS APPLICATION NOTE MUST VERIFY ANY FUNCTION DESCRIBED HEREIN IN THE REAL APPLICATION. INFINEON TECHNOLOGIES HEREBY DISCLAIMS ANY AND ALL WARRANTIES AND LIABILITIES OF ANY KIND (INCLUDING WITHOUT LIMITATION WARRANTIES OF NON-INFRINGEMENT OF INTELLECTUAL PROPERTY RIGHTS OF ANY THIRD PARTY) WITH RESPECT TO ANY AND ALL INFORMATION GIVEN IN THIS APPLICATION NOTE.

Information

For further information on technology, delivery terms and conditions and prices, please contact the nearest Infineon Technologies Office (www.infineon.com).

Warnings

Due to technical requirements, components may contain dangerous substances. For information on the types in question, please contact the nearest Infineon Technologies Office.

Infineon Technologies components may be used in life-support devices or systems only with the express written approval of Infineon Technologies, if a failure of such components can reasonably be expected to cause the failure of that life-support device or system or to affect the safety or effectiveness of that device or system. Life support devices or systems are intended to be implanted in the human body or to support and/or maintain and sustain and/or protect human life. If they fail, it is reasonable to assume that the health of the user or other persons may be endangered.

X-ON Electronics

Largest Supplier of Electrical and Electronic Components

Click to view similar products for [Power Management IC Development Tools](#) category:

Click to view products by [Infineon](#) manufacturer:

Other Similar products are found below :

[EVB-EP5348UI](#) [MIC23451-AAAYFL EV](#) [MIC5281YMME EV](#) [124352-HMC860LP3E](#) [DA9063-EVAL](#) [ADP122-3.3-EVALZ](#) [ADP130-0.8-EVALZ](#) [ADP130-1.8-EVALZ](#) [ADP1740-1.5-EVALZ](#) [ADP1870-0.3-EVALZ](#) [ADP1874-0.3-EVALZ](#) [ADP199CB-EVALZ](#) [ADP2102-1.25-EVALZ](#) [ADP2102-1.875EVALZ](#) [ADP2102-1.8-EVALZ](#) [ADP2102-2-EVALZ](#) [ADP2102-3-EVALZ](#) [ADP2102-4-EVALZ](#) [AS3606-DB](#) [BQ25010EVM](#) [BQ3055EVM](#) [ISLUSBI2CKIT1Z](#) [LM2734YEVAL](#) [LP38512TS-1.8EV](#) [EVAL-ADM1186-1MBZ](#) [EVAL-ADM1186-2MBZ](#) [ADP122UJZ-REDYKIT](#) [ADP166Z-REDYKIT](#) [ADP170-1.8-EVALZ](#) [ADP171-EVALZ](#) [ADP1853-EVALZ](#) [ADP1873-0.3-EVALZ](#) [ADP198CP-EVALZ](#) [ADP2102-1.0-EVALZ](#) [ADP2102-1-EVALZ](#) [ADP2107-1.8-EVALZ](#) [ADP5020CP-EVALZ](#) [CC-ACC-DBMX-51](#) [ATPL230A-EK](#) [MIC23250-S4YMT EV](#) [MIC26603YJL EV](#) [MIC33050-SYHL EV](#) [TPS60100EVM-131](#) [TPS65010EVM-230](#) [TPS71933-28EVM-213](#) [TPS72728YFFEVM-407](#) [TPS79318YEQEV](#) [UCC28810EVM-002](#) [XILINXPWR-083](#) [LMR22007YMINI-EVM](#)