

RF ESD Protection Diodes

- ESD protection of RF antenna / interfaces or ultra high speed data lines acc. to:
IEC61000-4-2 (ESD): ± 15 KV (air / contact)
IEC61000-4-4 (EPT): 40 A (5/50 ns)
IEC61000-4-5 (surge): 5 A (8/20 μ s)
- Very low line capacitance: 0.4 pF @ 1 GHz
(0.2 pF per diode)
- Ultra low series inductance: 0.4 nH per diode
- Very low clamping voltage
- Ultra small leadless package: 1.2 x 0.8 x 0.39 mm³
- Pb-free (RoHS compliant) package

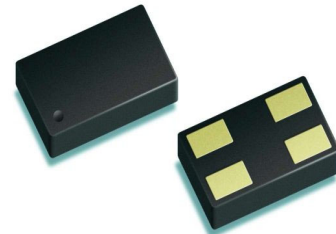

Applications in anti-parallel configuration

- For low RF signal levels without superimposed DC voltage: e.g. GPS, XM-Radio, Sirius, DVB, DMB, DAB, Remote Keyless Entry

Applications in rail-to-rail configuration

- For high RF signal levels or low RF signal levels with superimposed DC voltage: e.g. HDMI, S-ATA, Gbit Ethernet



ESD0P4RFL

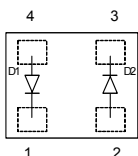

Type	Package	Configuration	Marking
ESD0P4RFL	TSLP-4-7	anti-parallel	E4

Maximum Ratings at $T_A = 25^\circ\text{C}$, unless otherwise specified

Parameter	Symbol	Value	Unit
ESD contact discharge ¹⁾	V_{ESD}	15	kV
Peak pulse current ($t_p = 8 / 20 \mu\text{s}$) ²⁾	I_{pp}	5	A
Operating temperature range	T_{op}	-55...150	°C
Storage temperature	T_{stg}	-65...150	

Electrical Characteristics at $T_A = 25^\circ\text{C}$, unless otherwise specified

Parameter	Symbol	Values			Unit
		min.	typ.	max.	
Characteristics -					
Reverse working voltage ³⁾	V_{RWM}	-	-	50	V
Reverse current ³⁾ $V_R = 50 \text{ V}$	I_R	-	20	100	nA
Forward clamping voltage ²⁾ $I_{\text{PP}} = 5 \text{ A}$	V_{FC}	-	6	9	V
Diode capacitance ⁴⁾ $V_R = 0 \text{ V}, f = 1 \text{ GHz}$	C_T	-	0.4	-	pF
Series inductance per diode	L_S	-	0.4	-	nH

¹⁾ V_{ESD} according to IEC61000-4-2, only valid in anti-parallel or rail-to-rail connection.

Please refer to the application examples.

²⁾ I_{pp} according to IEC61000-4-5, only valid in anti-parallel or rail-to-rail connection.

Please refer to the application examples.

³⁾Only valid in rail-to-rail configuration with $V_{\text{CC}} \leq V_{\text{RWM}}$

⁴⁾Total capacitance line to ground (2 diodes in parallel)

Forward clamping voltage $V_{FC} = f(I_{PP})$

$t_p = 8 / 20 \mu s$

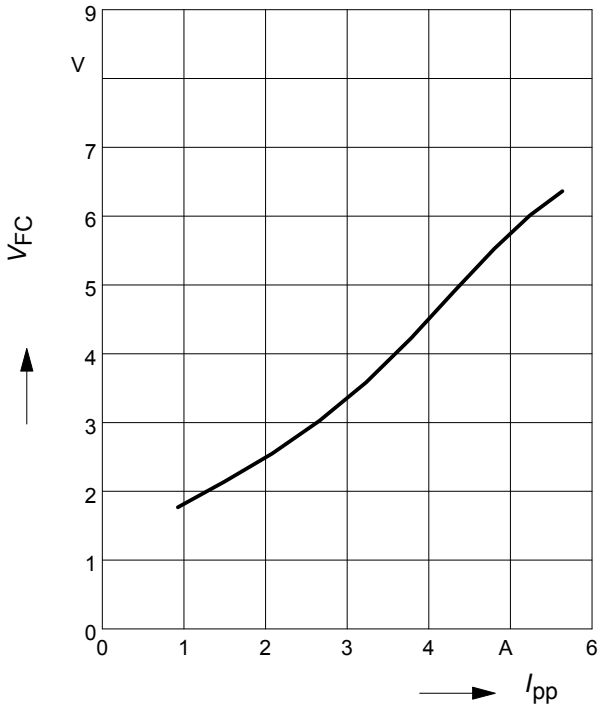

Reverse current $I_R = f(V_R)$

$T_A = \text{Parameter}$

leakage in rail-to-rail configuration

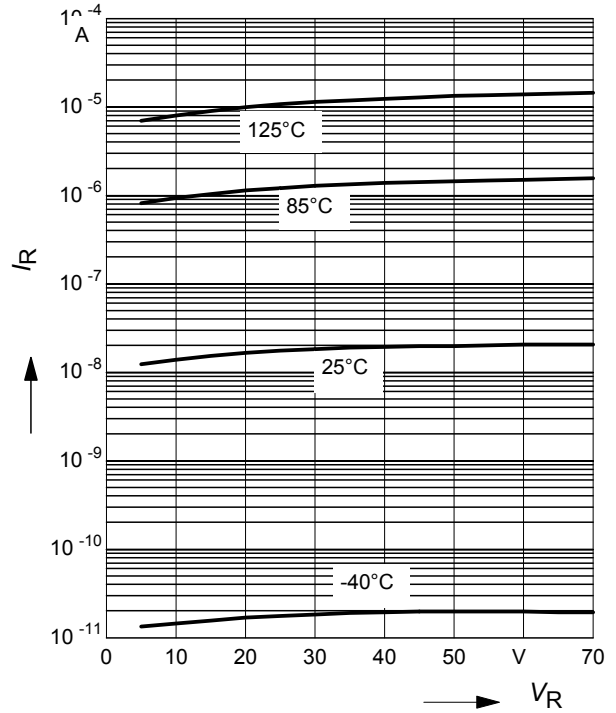

Forward current $I_F = f(V_F)$

leakage in anti-parallel configuration

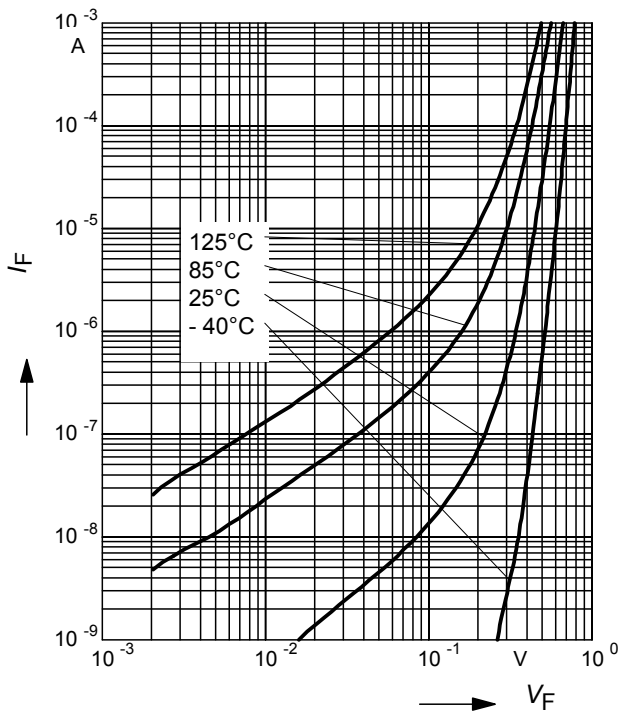

Line capacitance $C_T = f(f)$

$V_R = 0 V$

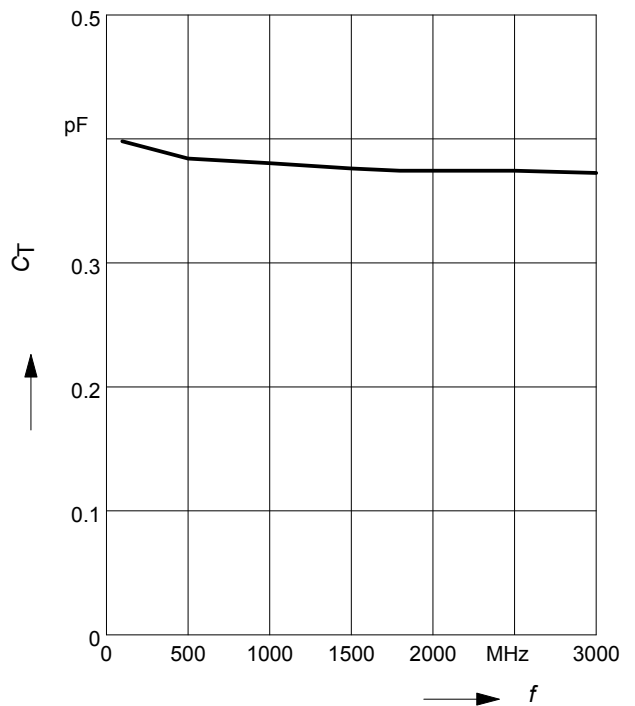

Insertion loss $I_L = -|S_{21}|^2 = f(f)$

$V_R = 0 \text{ V}$, $Z = 50 \Omega$

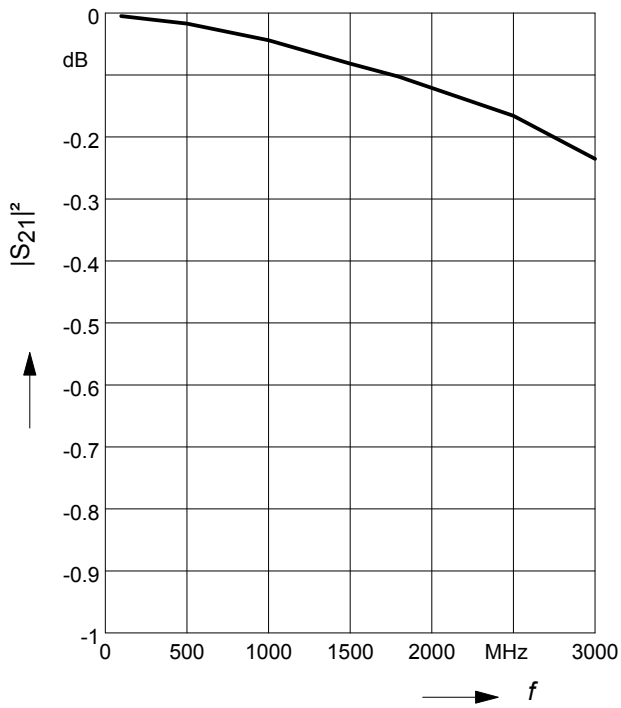

1. Application example ESD0P4RFL

1 RF signal channel, anti-parallel configuration

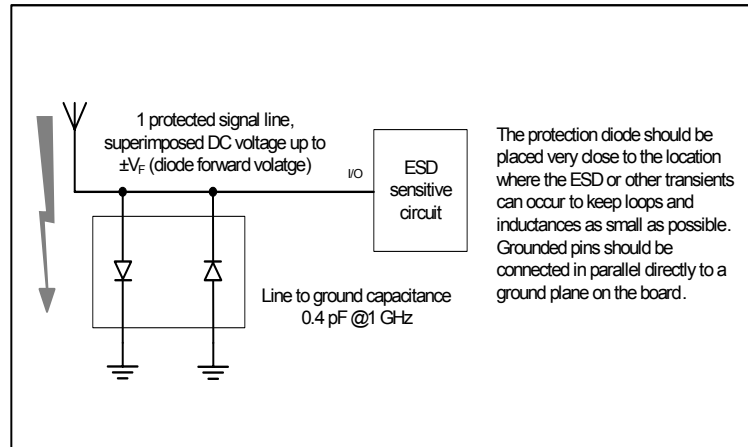

2. Application example ESD0P4RFL

1 RF signal channel, rail-to-rail configuration

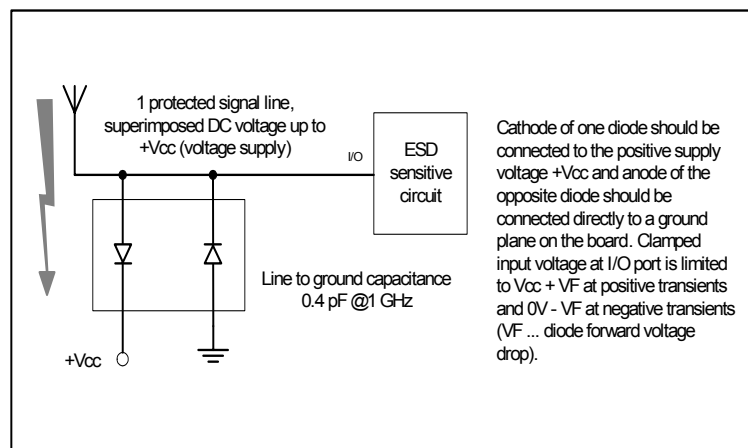

Package Outline

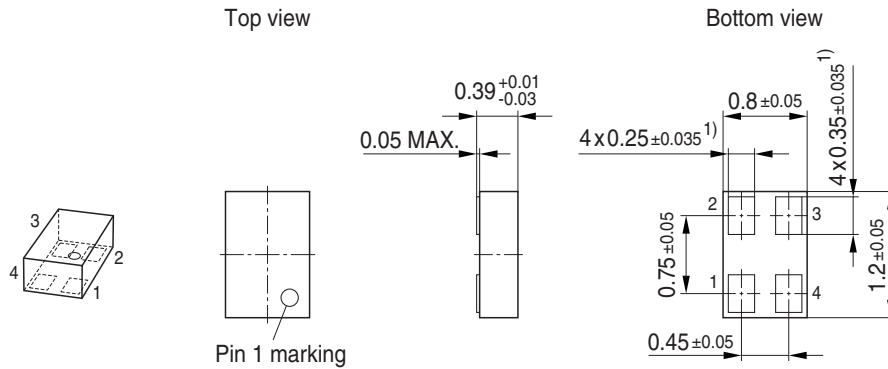

1) Dimension applies to plated terminal

Foot Print

For board assembly information please refer to Infineon website "Packages"

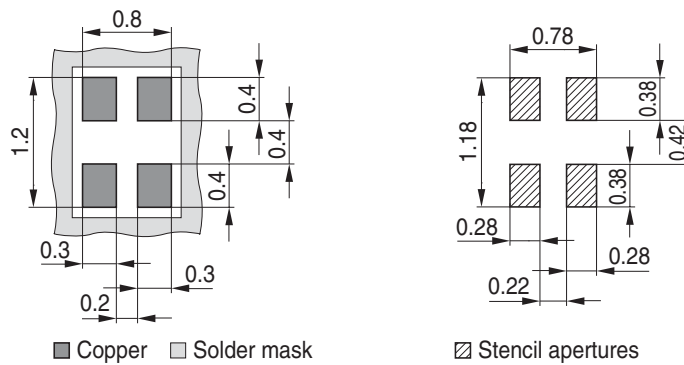

Marking Layout (Example)

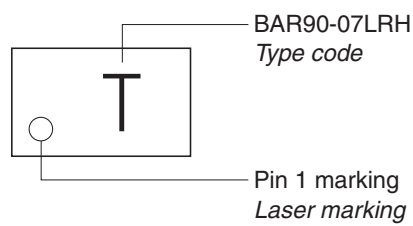

Standard Packing

Reel \varnothing 180 mm = 15.000 Pieces/Reel

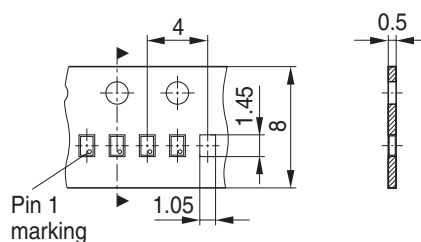

Edition 2009-11-16

**Published by
Infineon Technologies AG
81726 Munich, Germany**

**© 2009 Infineon Technologies AG
All Rights Reserved.**

Legal Disclaimer

The information given in this document shall in no event be regarded as a guarantee of conditions or characteristics. With respect to any examples or hints given herein, any typical values stated herein and/or any information regarding the application of the device, Infineon Technologies hereby disclaims any and all warranties and liabilities of any kind, including without limitation, warranties of non-infringement of intellectual property rights of any third party.

Information

For further information on technology, delivery terms and conditions and prices, please contact the nearest Infineon Technologies Office (www.infineon.com).

Warnings

Due to technical requirements, components may contain dangerous substances. For information on the types in question, please contact the nearest Infineon Technologies Office.

Infineon Technologies components may be used in life-support devices or systems only with the express written approval of Infineon Technologies, if a failure of such components can reasonably be expected to cause the failure of that life-support device or system or to affect the safety or effectiveness of that device or system. Life support devices or systems are intended to be implanted in the human body or to support and/or maintain and sustain and/or protect human life. If they fail, it is reasonable to assume that the health of the user or other persons may be endangered.

X-ON Electronics

Largest Supplier of Electrical and Electronic Components

Click to view similar products for [ESD Suppressors / TVS Diodes](#) category:

Click to view products by [Infineon](#) manufacturer:

Other Similar products are found below :

[60KS200C](#) [D12V0H1U2WS-7](#) [D18V0L1B2LP-7B](#) [82356050220](#) [D5V0F4U5P5-7](#) [D5V0M5U6V-7](#) [NTE4902](#) [P4KE27CA](#) [P6KE11CA](#)
[P6KE39CA-TP](#) [P6KE8.2A](#) [SA110CA](#) [SA60CA](#) [SA64CA](#) [SMBJ12CATR](#) [SMBJ8.0A](#) [SMLJ30CA-TP](#) [ESD112-B1-02EL E6327](#)
[ESD119B1W01005E6327XTSA1](#) [ESD5V0J4-TP](#) [ESD5V0L1B02VH6327XTSA1](#) [ESD7451N2T5G](#) [19180-510](#) [CPDT-5V0USP-HF](#)
[3.0SMCJ33CA-F](#) [3.0SMCJ36A-F](#) [HSPC16701B02TP](#) [D3V3Q1B2DLP3-7](#) [D55V0M1B2WS-7](#) [DESD5V0U1BL-7B](#) [DRTR5V0U4SL-7](#)
[SCM1293A-04SO](#) [ESD203-B1-02EL E6327](#) [SM12-7](#) [SMF8.0A-TP](#) [SMLJ45CA-TP](#) [CEN955 W/DATA](#) [82350120560](#) [82356240030](#)
[VESD12A1A-HD1-GS08](#) [CPDUR5V0R-HF](#) [CPDUR24V-HF](#) [CPDQC5V0U-HF](#) [CPDQC5V0USP-HF](#) [CPDQC5V0-HF](#) [D1213A-01LP4-7B](#)
[D1213A-02WL-7](#) [ESDLIN1524BJ-HQ](#) [5KP100A](#) [5KP15A](#)