

# 600 W Half-Bridge LLC evaluation board

EVAL\_600W\_LLC\_12V\_C7\_D  
digital & analog



# Table of contents

1

General description

2

Efficiency results

3

Design concept

# General

## Description:

The "**EVAL\_600W\_LLC\_12V\_C7**" - evaluation board shows how to design a Half-Bridge LLC stage of a server SMPS with the target to meet 80+ Titanium standard efficiency requirements. On this purpose there has been applied latest CoolMOS™ technology [IPP60R180C7](#) 600 V power MOSFET on the primary side and OptiMOS™ low voltage power MOSFET in SuperSO8 [BSC010N04LS](#) in the synchronous rectification secondary stage, in combination with QR CoolSET™ [ICE2QR2280Z](#), hi-low side driver [2EDL05N06PF](#), low-side Gate Driver [2EDN7524F](#) and a LLC Controller [ICE2HS01G](#) for the analog or [XMC4200](#) in the digital version.

## Summary of features:

- › Output voltage: 12 V
- › Output current: 50 A
- › Efficiency @ 10% load > 95%
- › Peak efficiency @ 50% load > 97,8%



## The following variants are available:

- › 600W 12V LLC **analog** version with CoolMOS™ C7, [IPP60R180C7](#), EVAL\_600W\_LLC\_12V\_C7
- › 600W 12V LLC **digital** version with CoolMOS™ C7, [IPP60R180C7](#), EVAL\_600W\_LLC\_12V\_C7\_D

# Example of system understanding: Infineon demo solution for Titanium HV DC/DC stage



Half-Bridge LLC with synchronous rectification in center tap configuration

$V_{in}$	350-410 V <sub>DC</sub>
$V_{in\_nom}$	380 V <sub>DC</sub>
$V_{out\_nom}$	12 V <sub>DC</sub>
$I_{out}$	50 A
$P_o$	600 W
$f_{res} = f_0$	157 kHz
$f_{min}$	90 kHz
$f_{max}$	210 kHz
Transformer turns ratio	16:1
$C_r$	66 nF
$L_r$	15.5 $\mu$ H
$L_m$	195 $\mu$ H

**Primary HV MOSFETs**  
**CoolMOS™ IPP60R180C7**

- Reduced gate charge ( $Q_g$ )
- > Reduced  $E_{off}$
  - > High body diode ruggedness

**SR MOSFETs**  
**OptiMOS™ BSC010N04LS**

- New generation
- > Best FOM  $R_{DS(on)} \times Q_g$
  - > Best FOM  $R_{DS(on)} \times Q_{oss}$

**HB Gate Drive IC**

2EDL05N06PF

**Non isolated LS Gate Drive**

2EDN7524F

**LLC controller**

Digital XMC4200 / Analog ICE2HS01G

**Bias QR Flyback controller**

ICE2QR2280Z

**SR MOSFETs**

BSC010N04LS

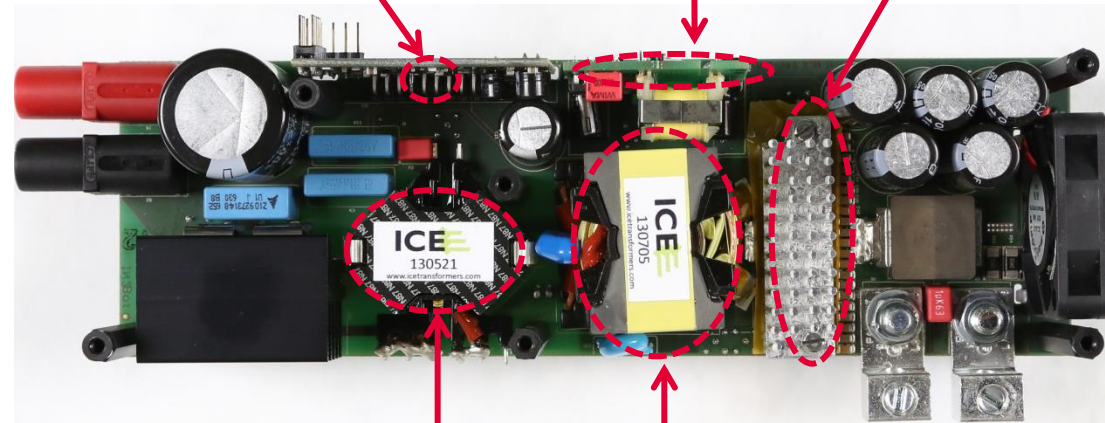

**Resonant inductor**

RM12 core

**Transformer**

PQ35/35 core

# Control board analog & digital

## Two possible solution to control Infineon`s 600 W LLC evaluation board

### Analog - ICE2HS01G

- > Resonant mode controller for Half-Bridge LLC resonant converter with synchronous rectification drives
- > Driving signal for synchronous rectification which support full operation of Half-Bridge LLC resonant converter
- > 20-pin DSO package
- > 30 kHz to 1MHz switching frequency
- > 50% duty cycle for both primary and secondary gate drives
- > Adjustable dead time with high accuracy

### Digital - XMC4200-Q48K256 AB

- > ARM® Cortex®-M4, 80 MHz, incl. single cycle DSP MAC and floating point unit (FPU)
- > 8-channel DMA + dedicated DMA for USB
- > USB 2.0 full-speed device
- > CPU Frequency: 80 MHz
- > eFlash: 256 kB including hardware ECC
- > 40 kB SRAM
- > Package: PG-LQFP-48

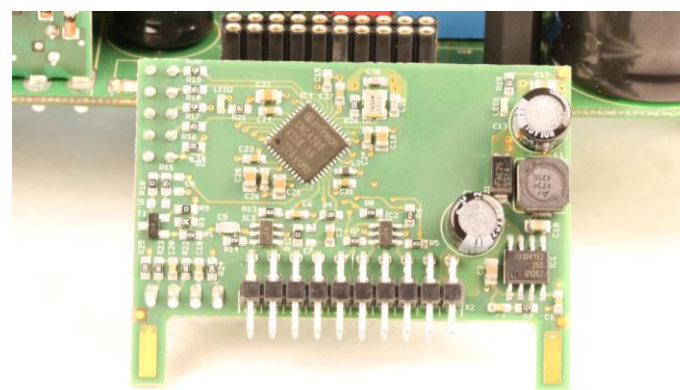
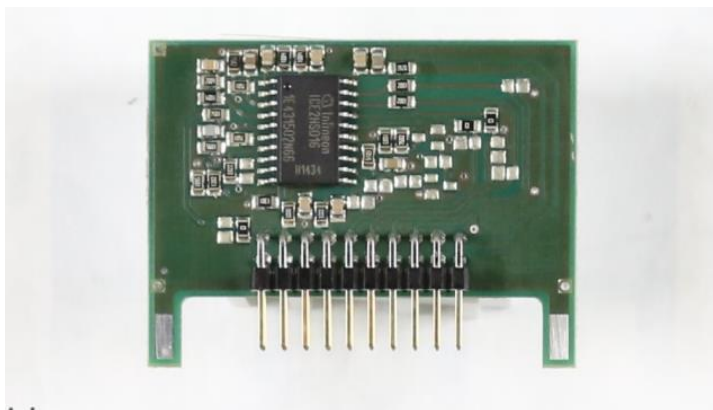

# PCB boards layout: main power board and control and bias daughter boards

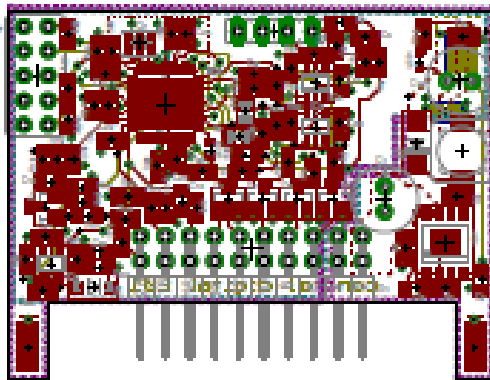
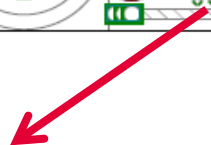
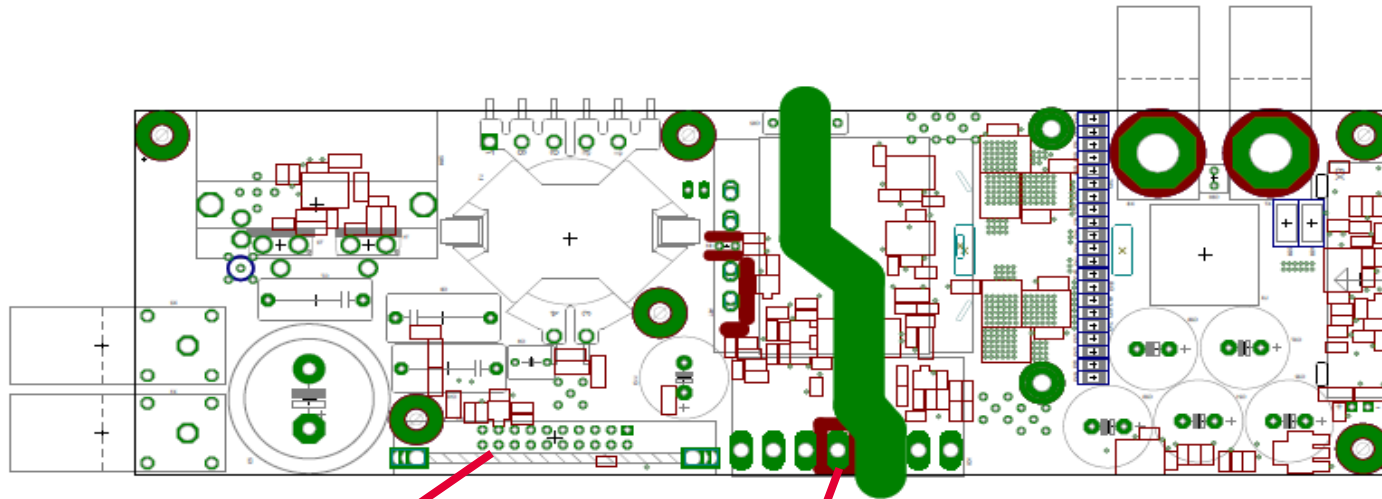

Controller board

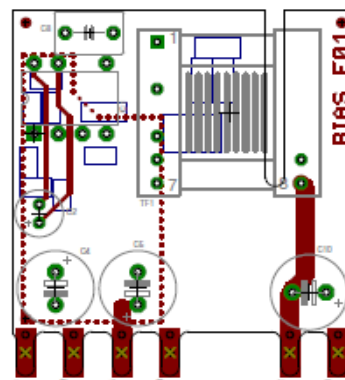

Bias board

- Power density  $>20 \text{ W/inch}^3$

# Main power board schematic (digital)

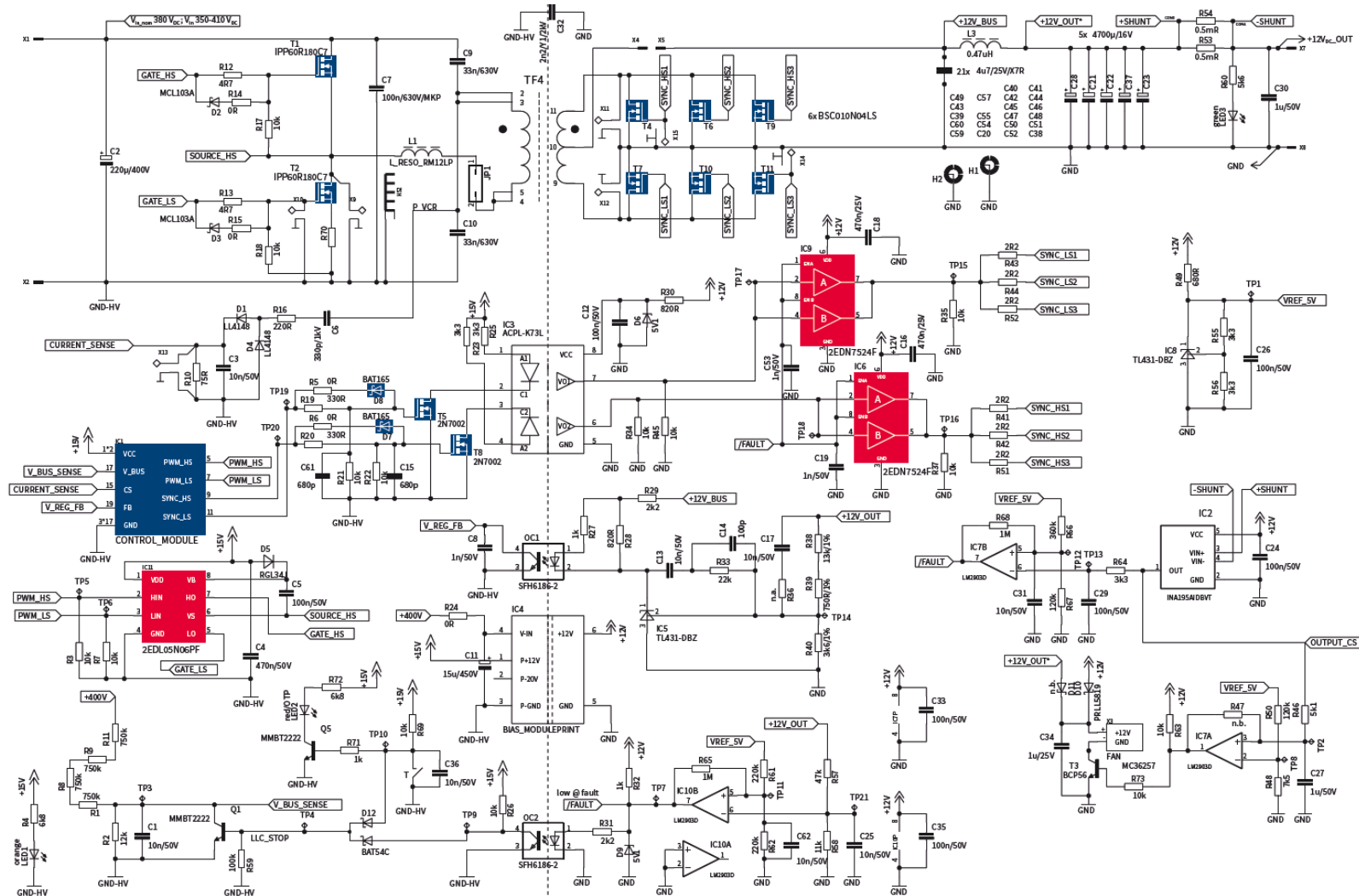

# Bias board schematic

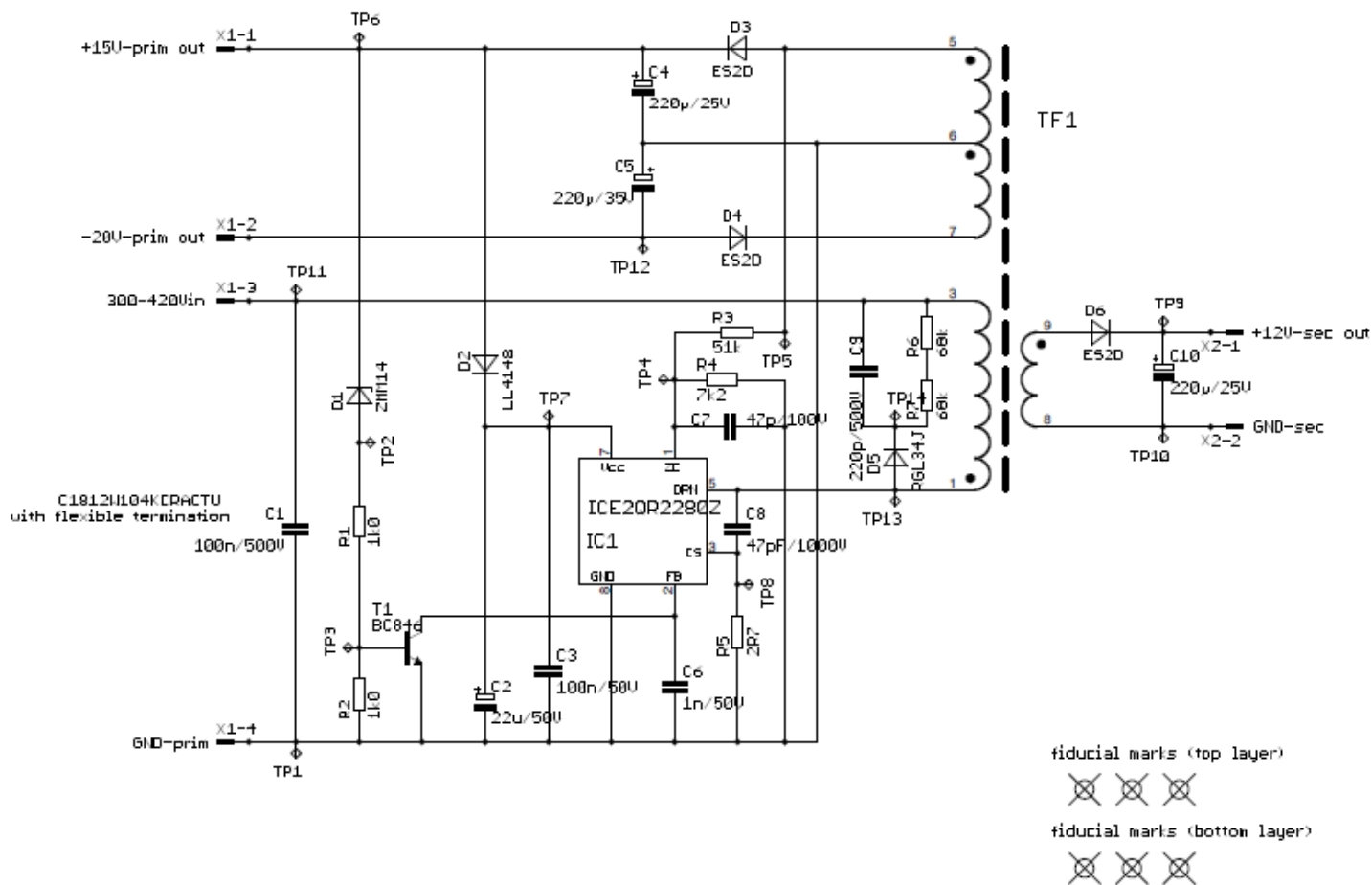



# Analog control board schematic

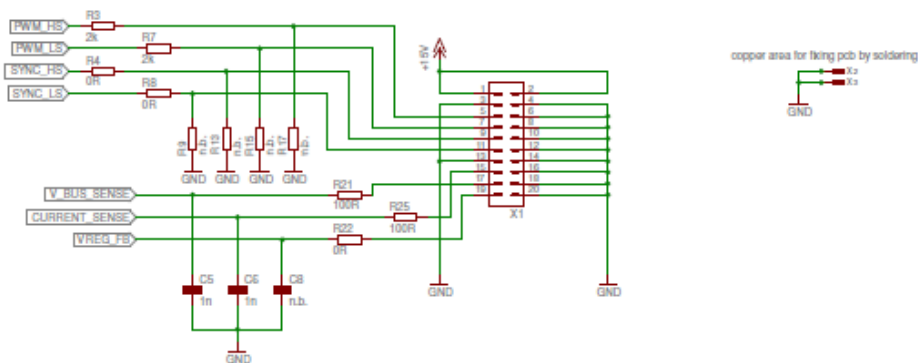

copper area for fixing pcb by soldering

fiducial marks on top layer

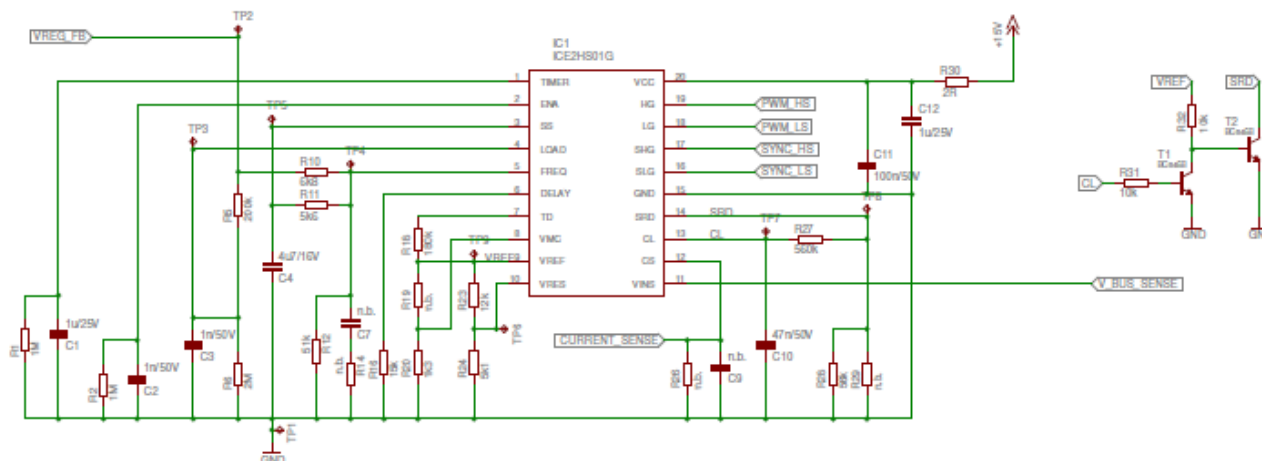

# Digital control board schematic

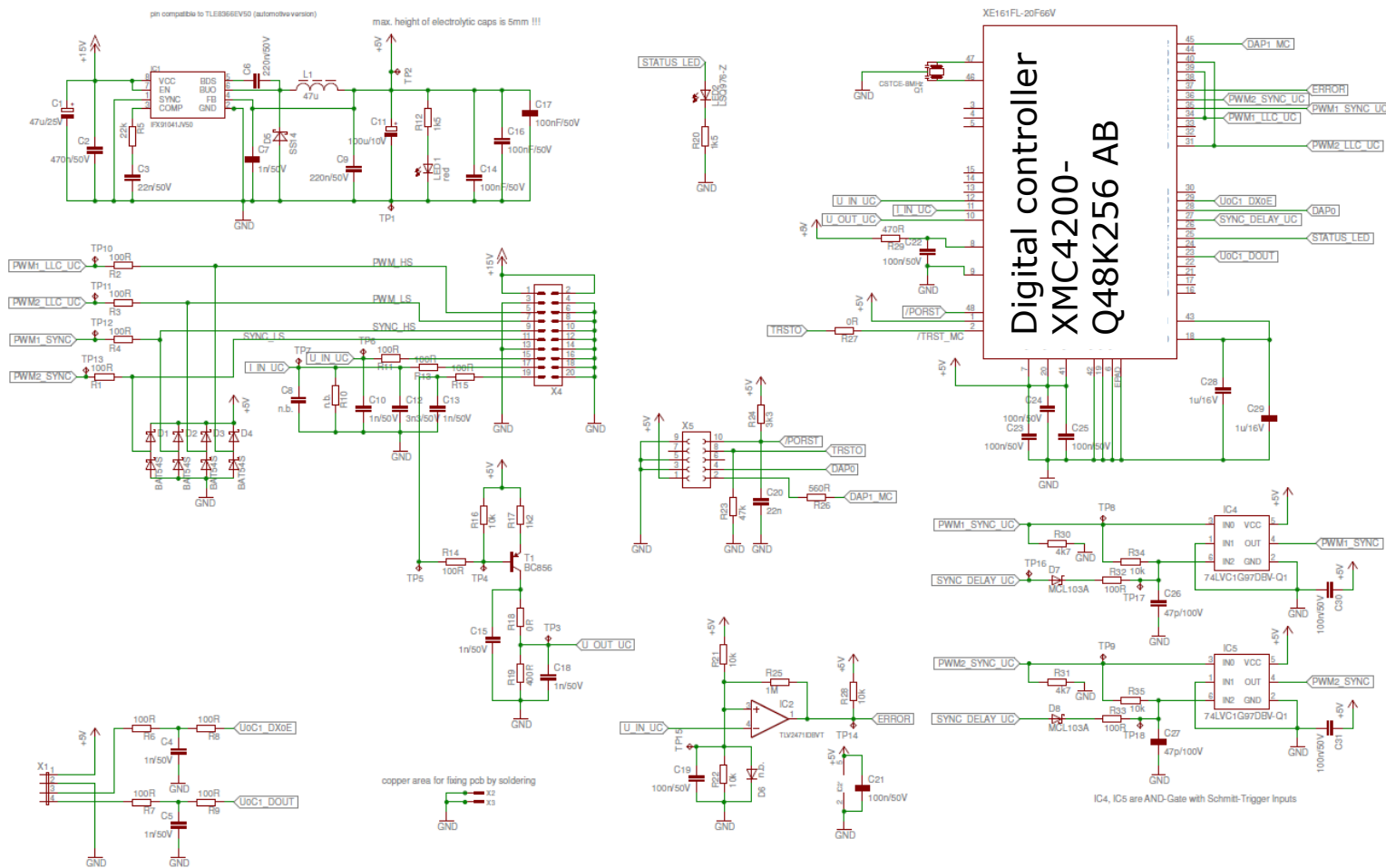

# PCB structure

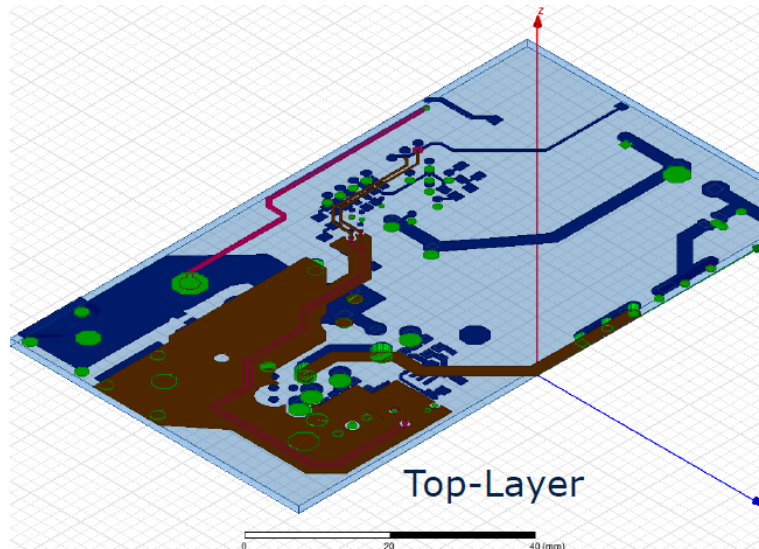
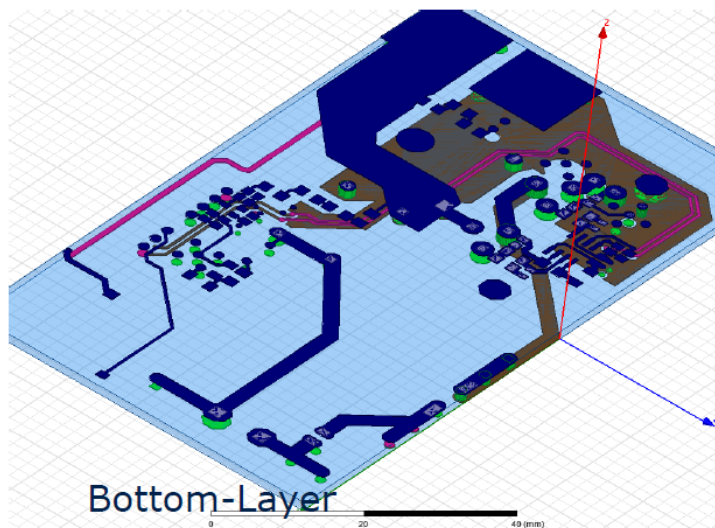

## PCB-Stackup

Nr	Copper	Isolation
1	<input type="text" value="0.07mm"/>	<input type="text" value="0.15mm"/>
2	<input type="text" value="0.07mm"/>	<input type="text" value="0.93mm"/>
15	<input type="text" value="0.07mm"/>	<input type="text" value="0.15mm"/>
16	<input type="text" value="0.07mm"/>	
Gesamt: 1.51mm		

# BOM (rework from digital to analog)

Part	Value	Pcs	Tolerance	Device	Package	Description	Assembling info	Supplier
C3	470n/50V	1		C-EU_C0805	C0805	CAPACITOR	Replace 10n/50V with 470n/50V	
R19	4K3	1	±1%	R-EU_R0805	R0805	RESISTOR	Replace 330R with 4K3	
R20	4K3	1	±1%	R-EU_R0805	R0805	RESISTOR	Replace 330R with 4K3	
R36	56R	1	±1%	R-EU_R0805	R0805	RESISTOR	Assemble n.a. with 56R	
IC1	Board	1		Board	PCB	Analog_Controlcard		IFX

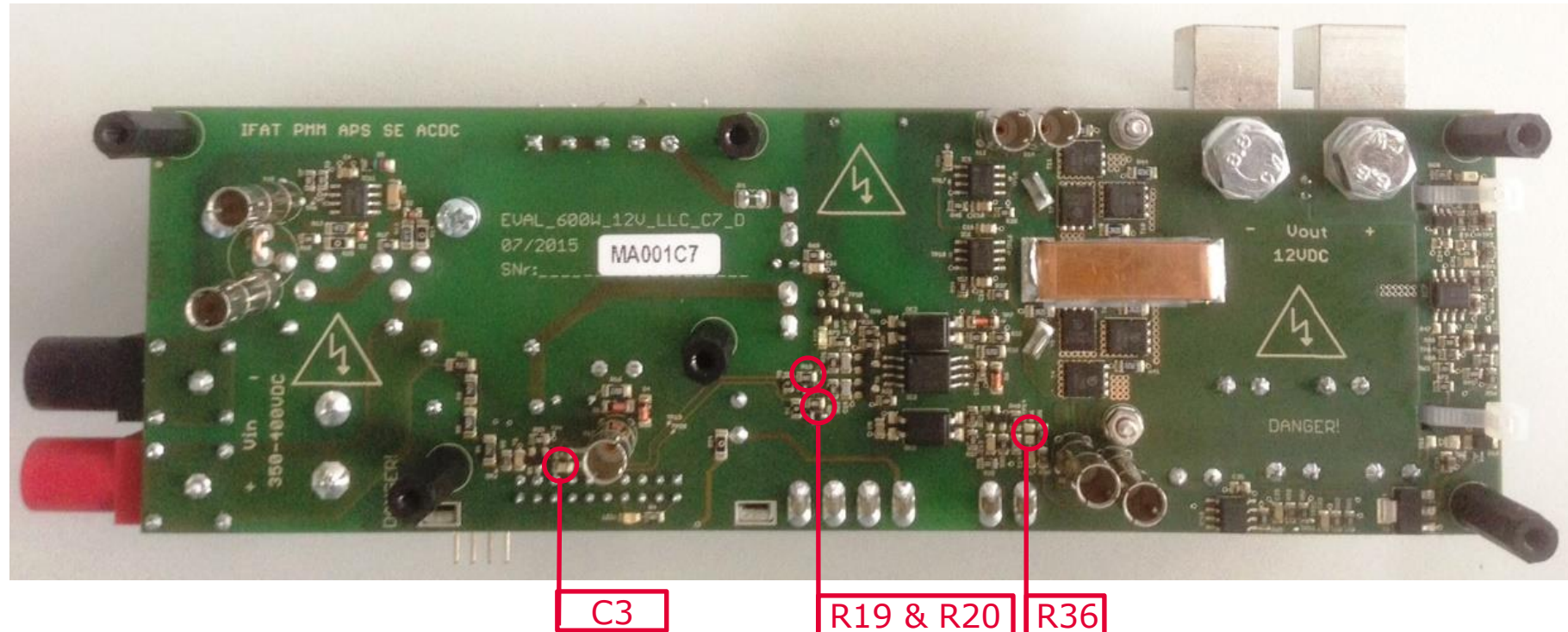

# Table of contents

I General description

II Efficiency results

III Design concept

# Automated efficiency measurement

Combination of converter design (resonant tank, transformer) and proper HV device election

Proper selection of SR LV device and secondary side

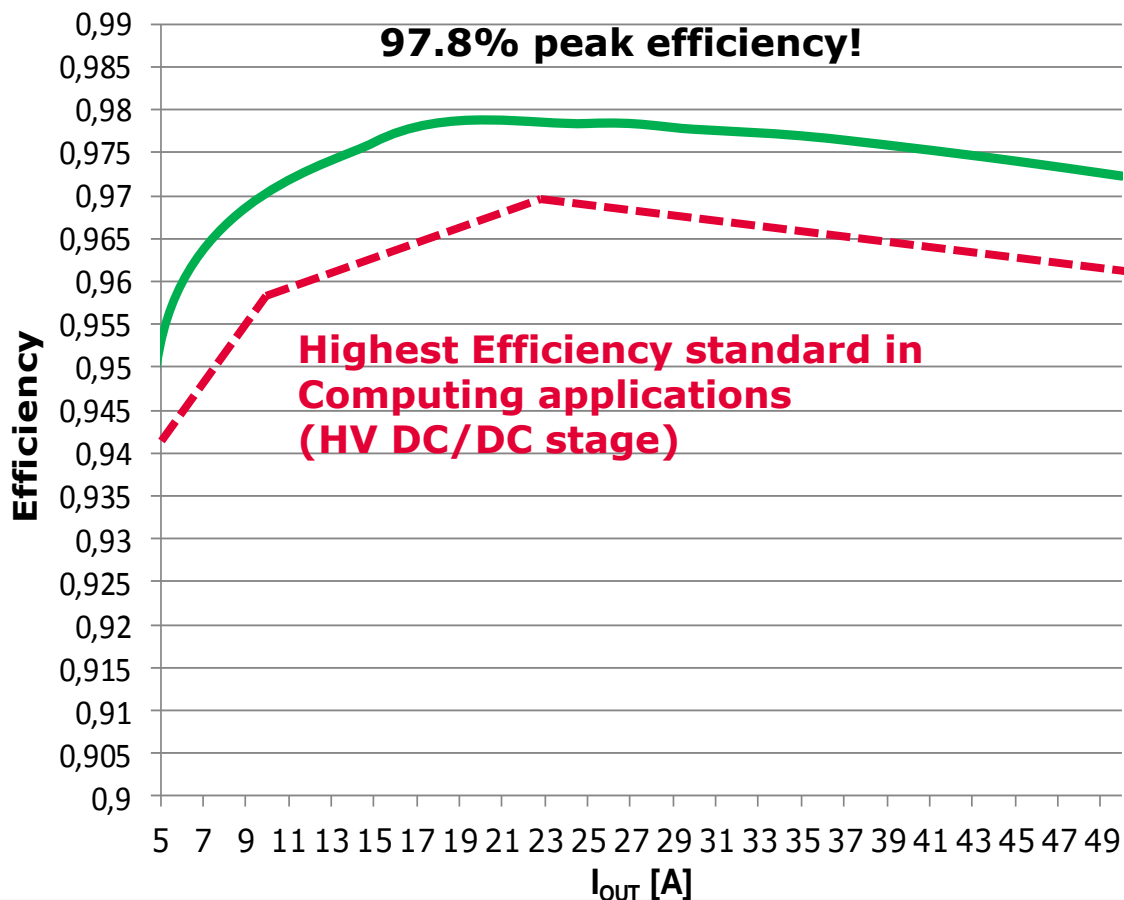

- > Output voltage: 12 V<sub>DC</sub>
- > Output current: 50 A
- > Efficiency: > 95% @ 10% load, V<sub>in</sub> = 380 V<sub>DC</sub>
- > Efficiency max: 97.8%, V<sub>in</sub> = 380 V<sub>DC</sub>

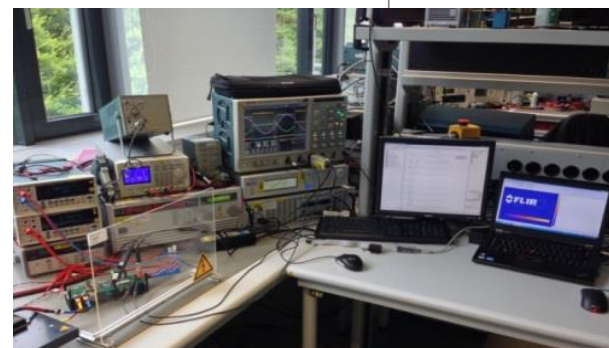

**0.1% Total accuracy**

# Table of contents

1

General description

2

Efficiency results

3

Design concept

## Design procedure: input data

$$n = \frac{V_{in\_nom}}{2 \cdot V_{out\_nom}}$$

$$M_{min} \equiv K_{min}(Q, m, F_x) = \frac{n \cdot V_{o\_min}}{V_{in\_max} / 2}$$

$$M_{max} \equiv K_{max}(Q, m, F_x) = \frac{n \cdot V_{o\_max}}{V_{in\_min} / 2}$$



# Resonant tank components and related resonant frequencies

- ›  $n = V_{in\_nom} / (2 \times V_o) = 380 / (2 \times 12) \approx 16$
- ›  $L_m = 195 \mu H$
- ›  $L_r = 15.5 \mu H$
- ›  $L_n = L_m / L_r = 12.5$
- ›  $C_r = 66 nF$

$$f_o = \frac{1}{2\pi \cdot \sqrt{L_r \cdot C_r}} = 157 kHz$$

$$f_p = \frac{1}{2\pi \cdot \sqrt{(L_r + L_m) \cdot C_r}} = 42.7 kHz$$

# Gain curves

DC - gain curve (600W LLC hardware revision C7)

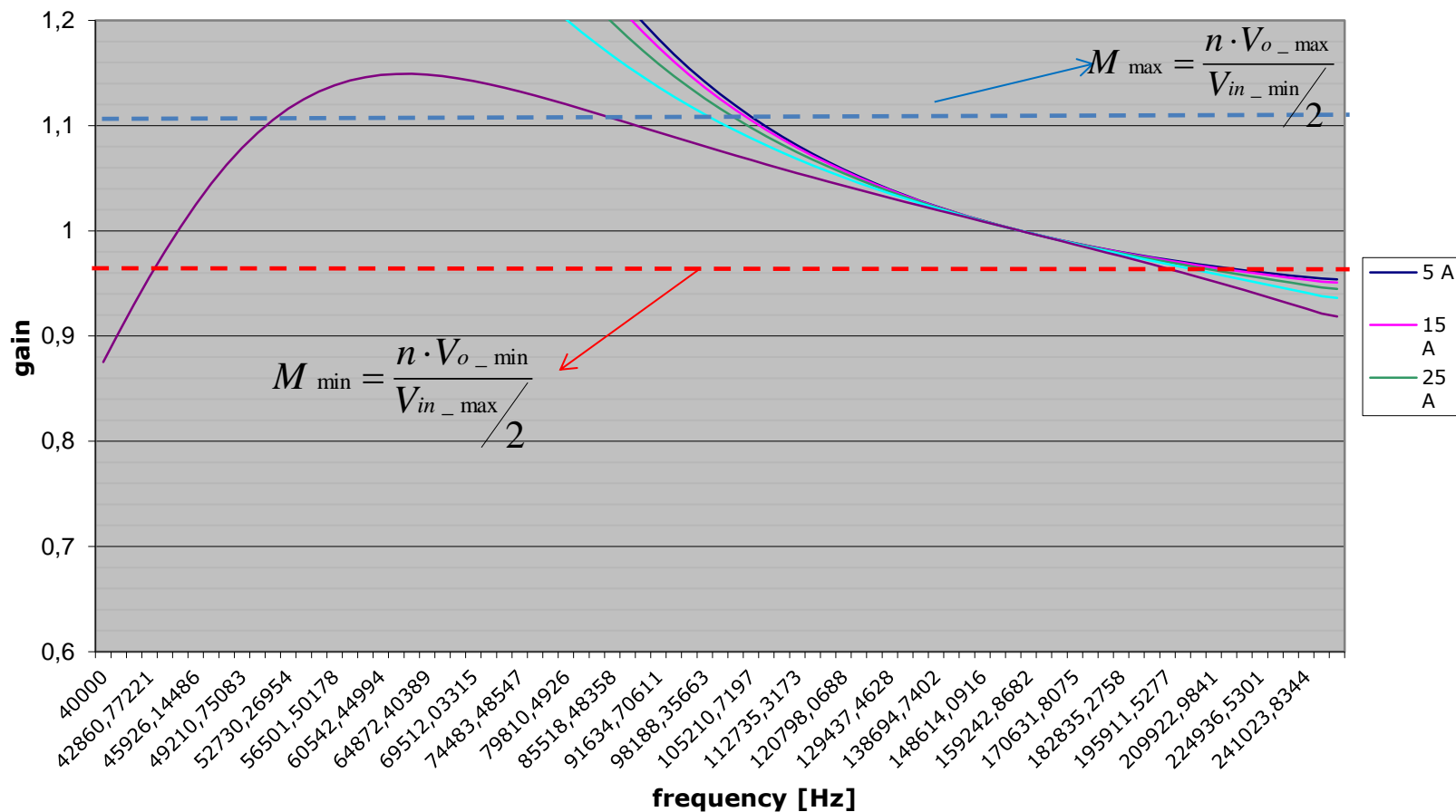

# Energy related calculations (Ref. IPP60R180C7 device parameters)

$$I_{mag\_min} = \frac{2 \cdot \sqrt{2}}{\pi} \cdot \frac{n \cdot V_o}{2\pi \cdot f_{sw\_max} \cdot L_m} = 0.672 \text{ A}$$

$$E_{nres\_min} = \frac{1}{2} \cdot (L_m + L_r) \cdot I_{mag\_min}^2 = 95.1 \mu\text{J}$$

$$E_{ncap\_max} = \frac{1}{2} \cdot (2Co(er)) \cdot V_{DS\_max}^2 \approx 9 \mu\text{J}$$

$$\Rightarrow E_{nres\_min} > E_{ncap\_max}$$

# $Q_{oss}, I_{mag,pk}, t_{dead,min}, t_{ecs}$ relationship

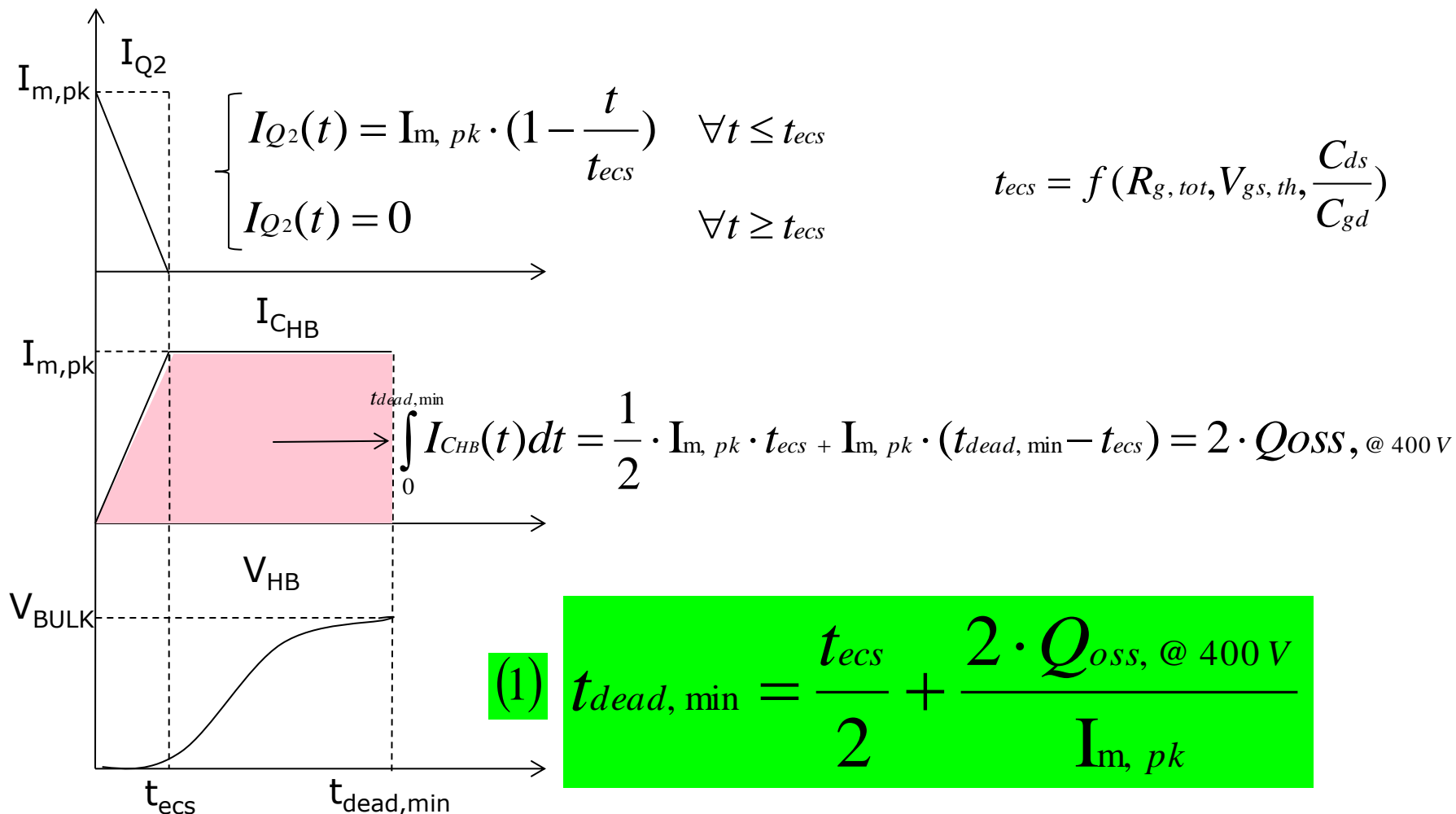

# Time related calculations (Ref. IPP60R180C7 device parameters)

$$I_{mag\_min} = \frac{2 \cdot \sqrt{2}}{\pi} \cdot \frac{n \cdot V_o}{2\pi \cdot f_{sw\_max} \cdot L_m} = 0.672 \text{ A}$$

$$I_{mag\_max} = \frac{2 \cdot \sqrt{2}}{\pi} \cdot \frac{n \cdot V_o}{2\pi \cdot f_{sw\_min} \cdot L_m} = 1.66 \text{ A}$$

$$t_{dead, min} = \frac{t_{ecs}}{2} + \frac{2 \cdot Q_{oss, @ 400V}}{I_{mag, max}} \approx 130 \text{ nsec}$$

$$t_{dead, max} = \frac{t_{ecs}}{2} + \frac{2 \cdot Q_{oss, @ 400V}}{I_{mag, min}} \approx 311 \text{ nsec}$$

# Main transformer structure: PQ35/35 core with TDK PC95 ferrite material

Wind.	Conductor	N°. of Turns	R o p e	Output pin	Winding layer	N°. layer	Sleeves			Notes	
							Col.	Ref. M.L.	Free length mm.		
N1a	2xLitz 90x0.10 Ref.3	0	+	2-3 *	8	1	Re	8	20	/	2 wires in 1 sleeve.
Insulation: 3 turns of polyester adhesive tape Ref.6											
N2	Copper foil	0	+	A	1	1	/	/	/	/	
N3	0.50x0.20 Ref.4	1		B C			/	/	/	/	
Insulation: 1 turn of polyester adhesive tape Ref.6 + 1 piece as showed in pictures											
N1b	2xLitz 90x0.10 Ref.3	0	+	* 4-5	8	1	Re	8	20	/	2 wires in 1 sleeve. Don't need correspondence
Insulation: 3 turns of polyester adhesive tape Ref.6											

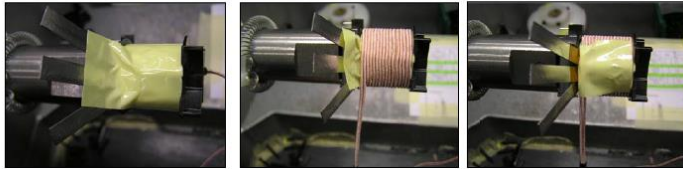

Insert piece of tape after the insulation of N2-N3. Wind N1b. Refold tape, block and connect the wires to pin

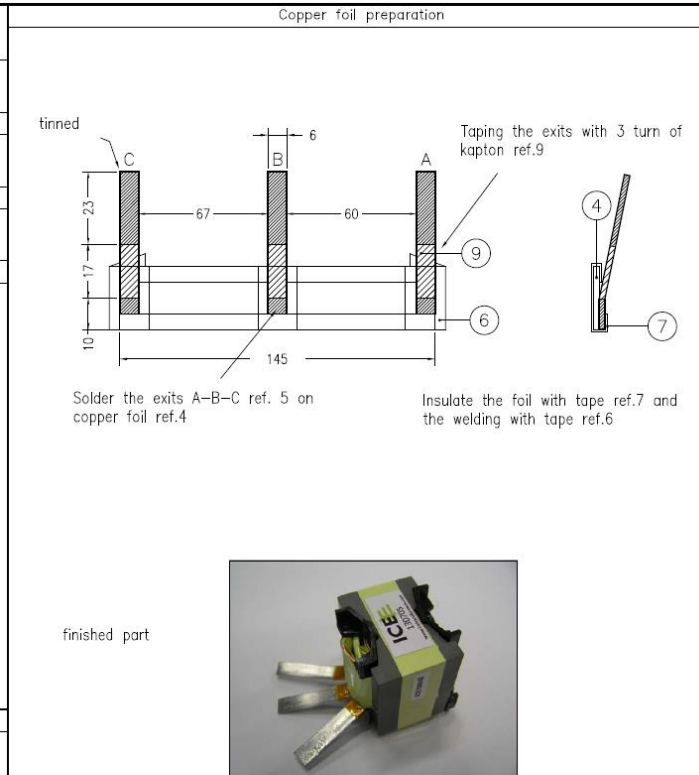
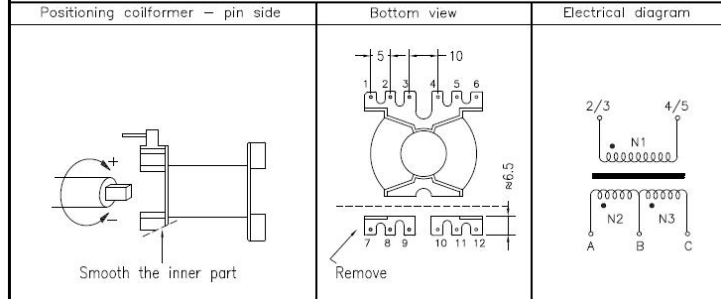

REV	APPR DATE	REF. MOD.	DESCRIPTION OF MODIFICATION	EDITING	CHECKING AND APPROVAL
02	21.07.15		Inserted label and pictures	C. Picciani	D. Di Giorgio
01	24.01.14		Release	C. Picciani	D. Di Giorgio

**TRANSFORMERS** | **Trasformatore PQ35/35 600W LLC converter (130705)**

Mod.	DOCUMENT TYPE	CODE	REVISION	RELEASE DATE	PAGE
AQ 05.09	P.F.	8065.0703.001	02	24.01.14	1of2

# Resonant choke: RM12 core, material N87

Wind.	Conductor type	N. of windings	R.P.C.	output pin	Winding Layer	N. of Layer	Tube			Notes																		
							Color	Ref.	Length mm																			
N1	Litz 120x0.10 Ref. 4	0 9	+	7+8+9 10+11	9	1	/ Red	/ 6	/ 20	Perpendicular crossing on tape ref.5																		
Insulation: 2 turns polyester tape Ref.5																												
<b>Bill of materials</b>																												
Ref.	Description																											
1	Coil Former RM12 12pins (B65816-C1512-T1 Epcos mat.Valox420 E45329)																											
2	Ferrite core RM12 gap 1.1mm (B65815-R87 Epcos)																											
3	RM12 clamp (B65816-A2002 Epcos)																											
4	Litz wire 120x0.100mm G1 (155°C E125660 or equivalent)																											
5	Polyester adhesive tape H=16mm thickness 0.06mm (P31 E178430 or equivalent)																											
6	Tube glass/silicone Ø1,5mm 4KV 20mm (GVES2500 E311983 or equivalent)																											
7	Activator for epoxy resin (IN1005 or equivalent)																											
8	Epoxy resin (36T or equivalent)																											
9	PVC label 24x12mm																											
10	Insulating varnish classH (AC43 E317427 or equivalent)																											
11	Polyestere label 4.7x14mm (7816 MH16411 or equivalent)																											
Winding rotation			Bottom View			Electrical drawing																						
<b>Assembling</b>																												
<p>* Serial number ICEAANNNN * 11</p> <p>max 25.5 1.8-0.3 33.02</p> <p>Fix core/coilformer with ref. 7+8</p> <p>max 46 5x5.08 max 41</p> <p>ICE 130521 www.satacoilformer.com</p> <p>Varnish with ref.10</p> <p>□ 0.8</p>																												
Dimensions in millimeter RoHS compliant																												
<b>Electrical test</b>																												
N°.	Test type	Test conditions							Limits																			
1	Inductance	7+8+9-10+11 @ 10 kHz - 100 mV							from 11.9 to 16.1 µH																			
<table border="1"> <thead> <tr> <th>Mod.</th> <th>DOCUMENT TYPE</th> <th>CODE</th> <th>REVISION</th> <th>EMISSION DATE</th> <th>PAGE</th> </tr> </thead> <tbody> <tr> <td>AQ 05.09</td> <td><b>P.F.</b></td> <td><b>8017.0901.012</b></td> <td><b>02</b></td> <td>23.01.14</td> <td>1 of 1</td> </tr> </tbody> </table>											Mod.	DOCUMENT TYPE	CODE	REVISION	EMISSION DATE	PAGE	AQ 05.09	<b>P.F.</b>	<b>8017.0901.012</b>	<b>02</b>	23.01.14	1 of 1						
Mod.	DOCUMENT TYPE	CODE	REVISION	EMISSION DATE	PAGE																							
AQ 05.09	<b>P.F.</b>	<b>8017.0901.012</b>	<b>02</b>	23.01.14	1 of 1																							
<table border="1"> <thead> <tr> <th>REV</th> <th>Appr. data</th> <th>Ref. Mod.</th> <th>Modification description</th> <th>Editing</th> <th>Checked and Approved</th> </tr> </thead> <tbody> <tr> <td>G2</td> <td>21.07.15</td> <td></td> <td>Inserted new label</td> <td>C. Picciani</td> <td>D. Di Giorgio</td> </tr> <tr> <td>G1</td> <td>23.01.14</td> <td></td> <td>Release</td> <td>C. Picciani</td> <td>D. Di Giorgio</td> </tr> </tbody> </table>											REV	Appr. data	Ref. Mod.	Modification description	Editing	Checked and Approved	G2	21.07.15		Inserted new label	C. Picciani	D. Di Giorgio	G1	23.01.14		Release	C. Picciani	D. Di Giorgio
REV	Appr. data	Ref. Mod.	Modification description	Editing	Checked and Approved																							
G2	21.07.15		Inserted new label	C. Picciani	D. Di Giorgio																							
G1	23.01.14		Release	C. Picciani	D. Di Giorgio																							
<table border="1"> <thead> <tr> <th>DESCRIPTION</th> <th>INDUCTANCE RM12 LLC resonant choke (130521)</th> </tr> </thead> <tbody> <tr> <td>TRANSFORMER</td> <td></td> </tr> </tbody> </table>											DESCRIPTION	INDUCTANCE RM12 LLC resonant choke (130521)	TRANSFORMER															
DESCRIPTION	INDUCTANCE RM12 LLC resonant choke (130521)																											
TRANSFORMER																												

# Evaluation board EVAL\_600W\_12V\_LLC\_C7

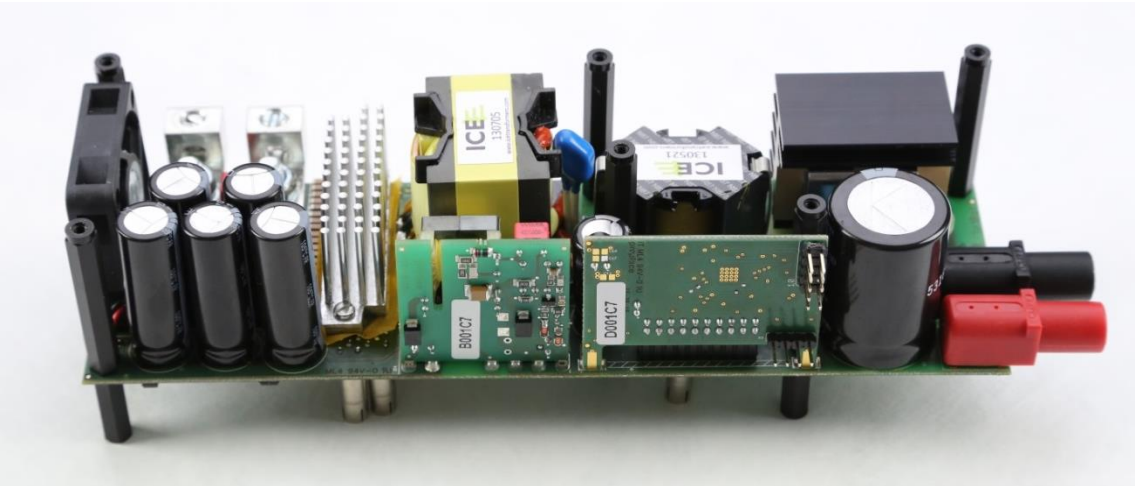



# Support slides 600W LLC evaluation board

## Evaluation board page

- Technical description
- Datasheets
- Parameters
- Related material
- Videos

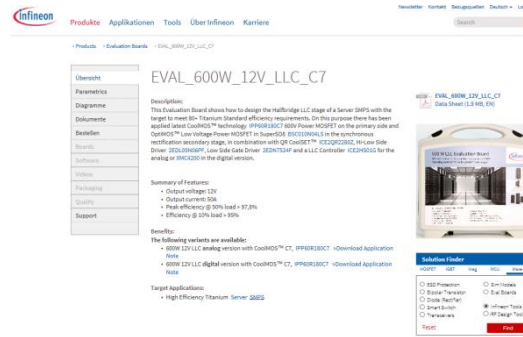

- [EVAL\\_600W\\_12V\\_LLC\\_C7](#)

## Product family pages

- Product brief
- Application notes
- Selection guides
- Datasheets and portfolio
- Videos
- Simulation models



- [650V CoolMOS™ C7](#)
- [XMC 32-Bit Industrial Microcontroller](#)
- [Resonant Mode Controller](#)
- [OptiMOS™ 5 40V and 60V](#)





Part of your life. Part of tomorrow.



## X-ON Electronics

Largest Supplier of Electrical and Electronic Components

*Click to view similar products for [Power Management IC Development Tools](#) category:*

*Click to view products by [Infineon](#) manufacturer:*

Other Similar products are found below :

[EVB-EP5348UI](#) [MIC23451-AAAYFL EV](#) [MIC5281YMME EV](#) [124352-HMC860LP3E](#) [DA9063-EVAL](#) [ADP122-3.3-EVALZ](#) [ADP130-0.8-EVALZ](#) [ADP130-1.8-EVALZ](#) [ADP1740-1.5-EVALZ](#) [ADP1870-0.3-EVALZ](#) [ADP1874-0.3-EVALZ](#) [ADP199CB-EVALZ](#) [ADP2102-1.25-EVALZ](#) [ADP2102-1.875EVALZ](#) [ADP2102-1.8-EVALZ](#) [ADP2102-2-EVALZ](#) [ADP2102-3-EVALZ](#) [ADP2102-4-EVALZ](#) [AS3606-DB](#) [BQ25010EVM](#) [BQ3055EVM](#) [ISLUSBI2CKIT1Z](#) [LM2734YEVAL](#) [LP38512TS-1.8EV](#) [EVAL-ADM1186-1MBZ](#) [EVAL-ADM1186-2MBZ](#) [ADP122UJZ-REDYKIT](#) [ADP166Z-REDYKIT](#) [ADP170-1.8-EVALZ](#) [ADP171-EVALZ](#) [ADP1853-EVALZ](#) [ADP1873-0.3-EVALZ](#) [ADP198CP-EVALZ](#) [ADP2102-1.0-EVALZ](#) [ADP2102-1-EVALZ](#) [ADP2107-1.8-EVALZ](#) [ADP5020CP-EVALZ](#) [CC-ACC-DBMX-51](#) [ATPL230A-EK](#) [MIC23250-S4YMT EV](#) [MIC26603YJL EV](#) [MIC33050-SYHL EV](#) [TPS60100EVM-131](#) [TPS65010EVM-230](#) [TPS71933-28EVM-213](#) [TPS72728YFFEVM-407](#) [TPS79318YEQEV](#) [UCC28810EVM-002](#) [XILINXPWR-083](#) [LMR22007YMINI-EVM](#)