

Bidirectional protection switch evaluation kit

User manual

About this document

Scope and purpose

Applications with lithium-ion batteries use battery management systems (BMS's) to monitor the battery state and ensure safe operation. The BMS is typically equipped with an electronic switch that disconnects the battery from the charger or loads under critical conditions.

This user manual describes the use of the bidirectional switch evaluation kit [EVAL_BDPS_DD_TOLL/G](#) and [EVAL_BDPS_DRIVER](#), which is intended to test and evaluate the MOSFET's performance.

Intended audience

This document is intended to guide engineers evaluating MOSFET performance by using this evaluation kit.

Table of contents

About this document	1
Table of contents	2
1 Introduction	3
2 Bidirectional switch	4
3 Board overview	5
3.1 EVAL_BDPS_DD_TOLL/G (bidirectional switch board)	5
3.2 Gate driver board	7
4 Board setup	9
4.1 Interfacing the boards.....	9
4.2 Connecting the boards with a battery or supply.....	9
4.3 Powering the gate driver board	10
4.4 Supplying gating signals to the gate driver board	11
5 Paralleling the boards	12
6 Protecting MOSFETs from avalanche	14
7 Plugging the boards into the user circuit	15
8 Test results	16
8.1 Test parameters	16
8.2 Current vs. temperature measurement over time	16
8.3 Waveforms.....	17
9 Appendix	18
9.1 EVAL_BDPS_DD_TOLL/G (bidirectional switch board)	18
9.1.1 Schematic.....	18
9.1.2 Bill of materials	18
9.1.3 Layout.....	19
9.2 EVAL_BDPS_DRIVER (gate driver board)	19
9.2.1 Schematic.....	19
9.2.2 Bill of materials	20
9.2.3 PCB layout	21
9.3 Copper bus bar dimensions.....	21
References	22
Revision history	23

1 Introduction

A bidirectional switch is an active electronic switch that can block the current in both directions for proper power management. In addition, these switches are widely used to protect the battery from abnormal conditions such as short-circuit, reverse voltage, overvoltage, etc.

2 Bidirectional switch

Bidirectional current blocking between two or more power sources is a necessary function, the power MOSFET can be connected either in source-to-source or drain-to-drain configuration, acting as the bidirectional protection switch (BDPS). The BDPS can be implemented by using two N-channel or P-channel FETs. N-channel FETs are preferred due to lower $R_{DS(on)}$ and lower cost compared to P-channel FETs.

Protection can be implemented by connecting a MOSFET either on the positive rail or on the negative rail of the source (e.g., a battery). **Figure 1** and **Figure 2** show the low-side (LS) and high-side (HS) switch configuration in the high-level block diagram of the BMS.

Read more about the different battery protection topologies and their advantages and disadvantages in [\[1\]](#).

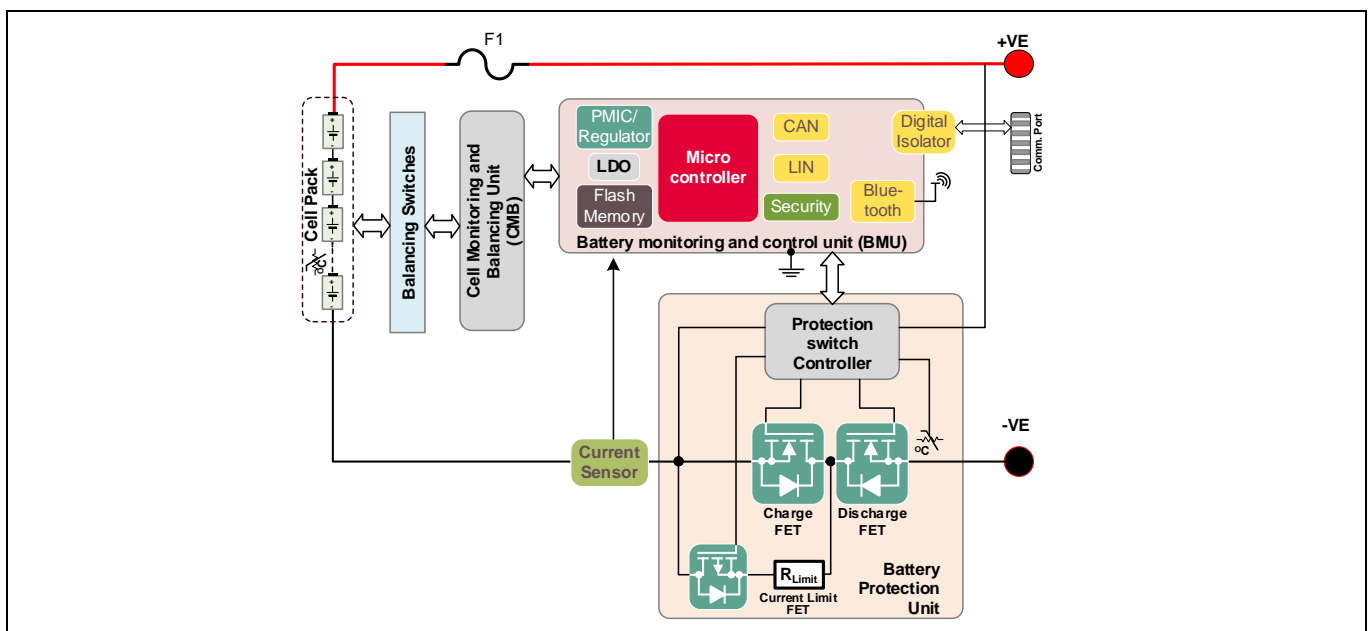

Figure 1 LS protection switch

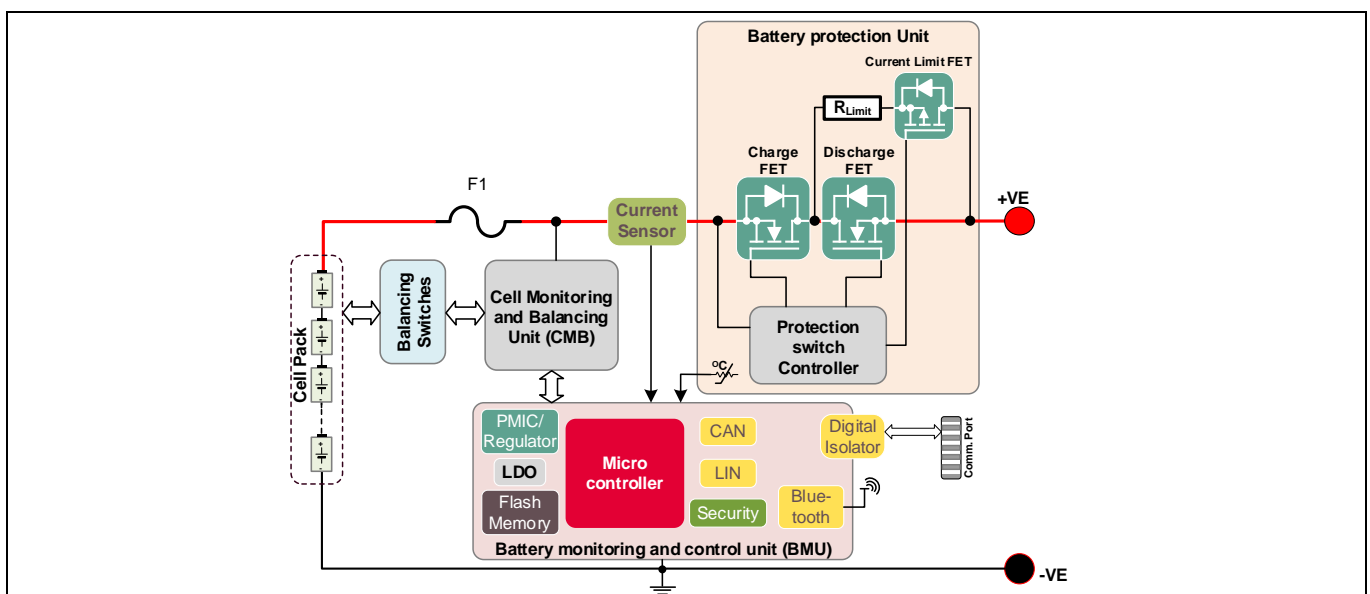

Figure 2 HS protection switch

3 Board overview

The performance of a MOSFET must be known before using it in the application. In this case, datasheets are the best sources. They help the designer to choose an appropriate MOSFET. However, the presence of various parasitic elements as shown in **Figure 3** can affect the MOSFET's performance in use.

Read more about MOSFET selection in the article “Ensuring the Safe Operation of MOSFETs in Bidirectional Protection Power Switch (BDPS) Applications” [2].

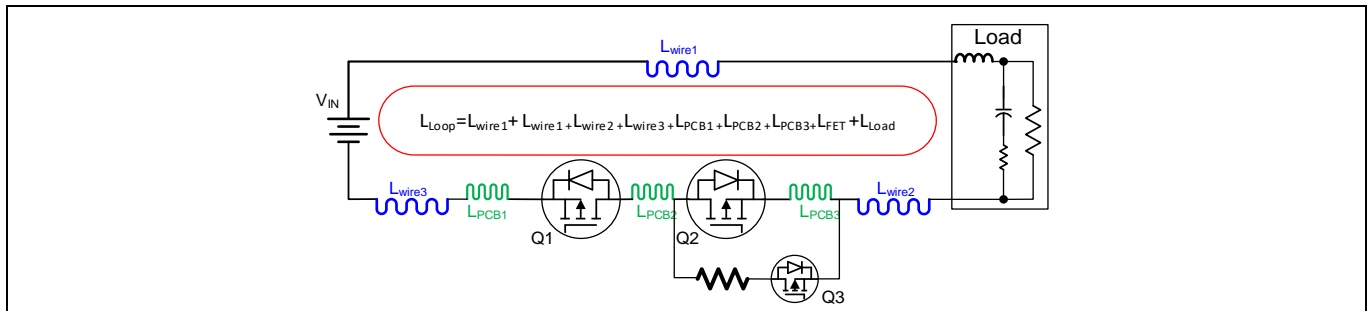

Figure 3 Protection switch with various parasitic elements

The evaluation boards are shown in **Figure 4**; the EVAL_BDPS_DD_TOLL/G and the EVAL_BDPS_DRIVER shown in **Figure 4** and **Figure 6**, respectively, offer a quick evaluation of MOSFETs using the TOLL or TOLG package. The designer can easily evaluate the MOSFETs on a bench or by plugging these boards into their design to evaluate a MOSFET for power loss, short-circuit, avalanche, etc.

3.1 EVAL_BDPS_DD_TOLL/G (bidirectional switch board)

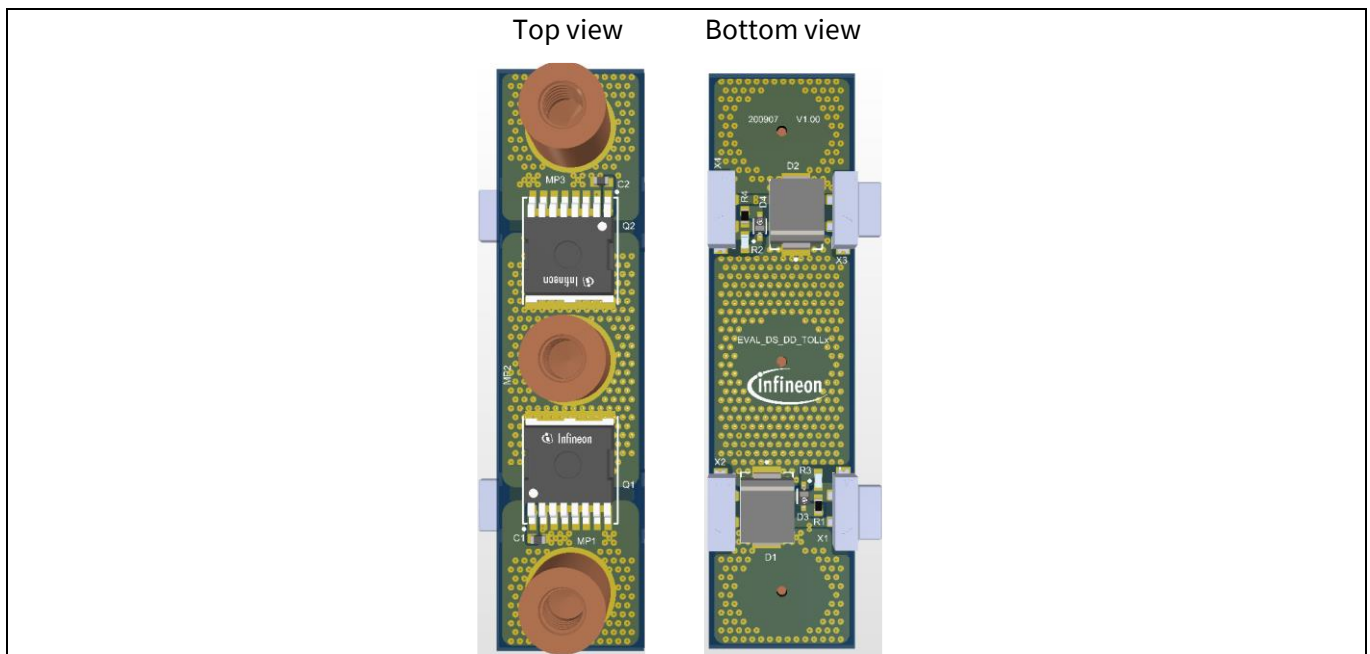

Figure 4 EVAL_BDPS_DD_TOLL/G (bidirectional switch board)

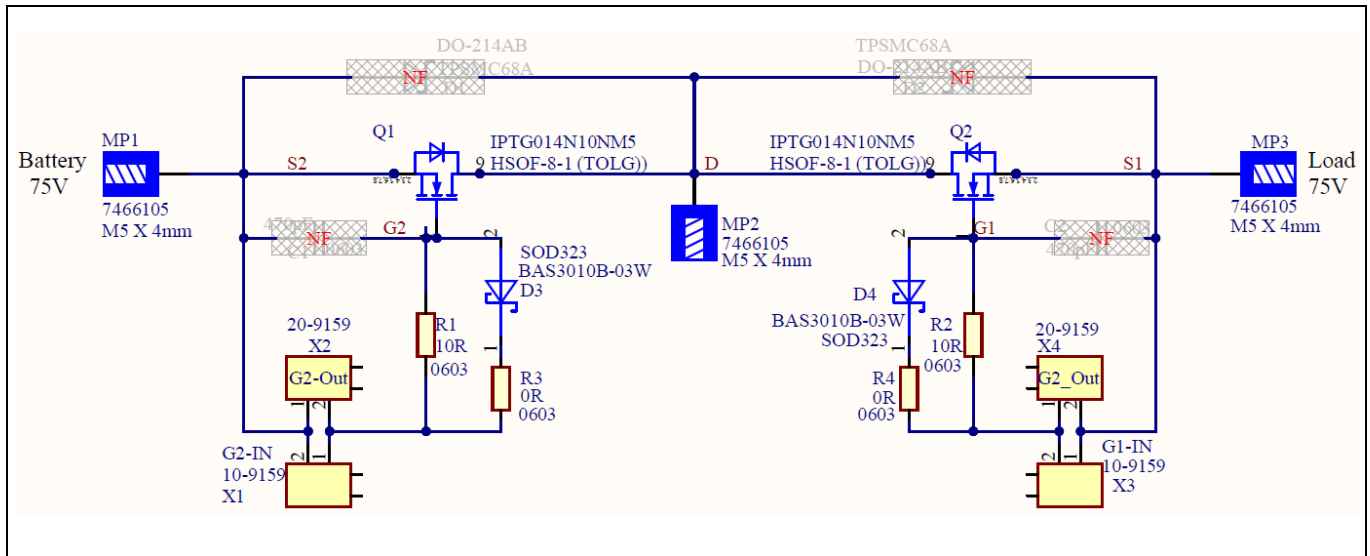

Figure 5 EVAL_BDPS_DD_TOLG (bidirectional switch board) schematic

Note: The schematic for the EVAL_BDPS_DD_TOLL evaluation board is the same as the one shown in [Figure 5](#), with the exception of the MOSFET being replaced with [IPT015N10N5](#).

The EVAL_BDPS_DD_TOLL/G evaluation board is a bidirectional switch board using MOSFETs connected in drain-to-drain configuration due to the advantages mentioned in [\[1\]](#). It is designed to support the following specification:

Table 1 Board specification

Specification	Values
Operating voltage (V_{IN})	36 to 75 V
Continuous output current (I_{OUT})	0 to 30 A
Voltage across X4	+/-15 V
Board size	65 x 16.5 mm
MOSFET	TOLL – EVAL_BDPS_DD_TOLL – IPT015N10N5 TOLG – EVAL_BDPS_DD_TOLG – IPTG014N10NM5

3.2 Gate driver board

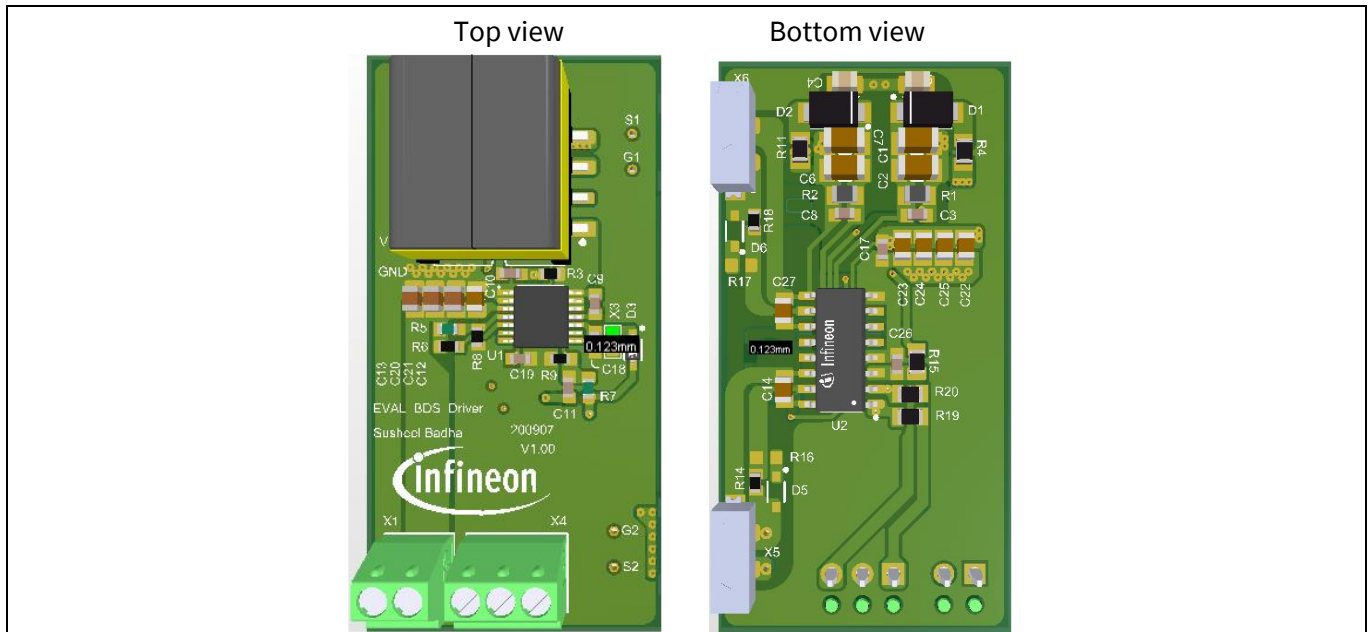

Figure 6 EVAL_BDPS_DRIVER (gate driver board)

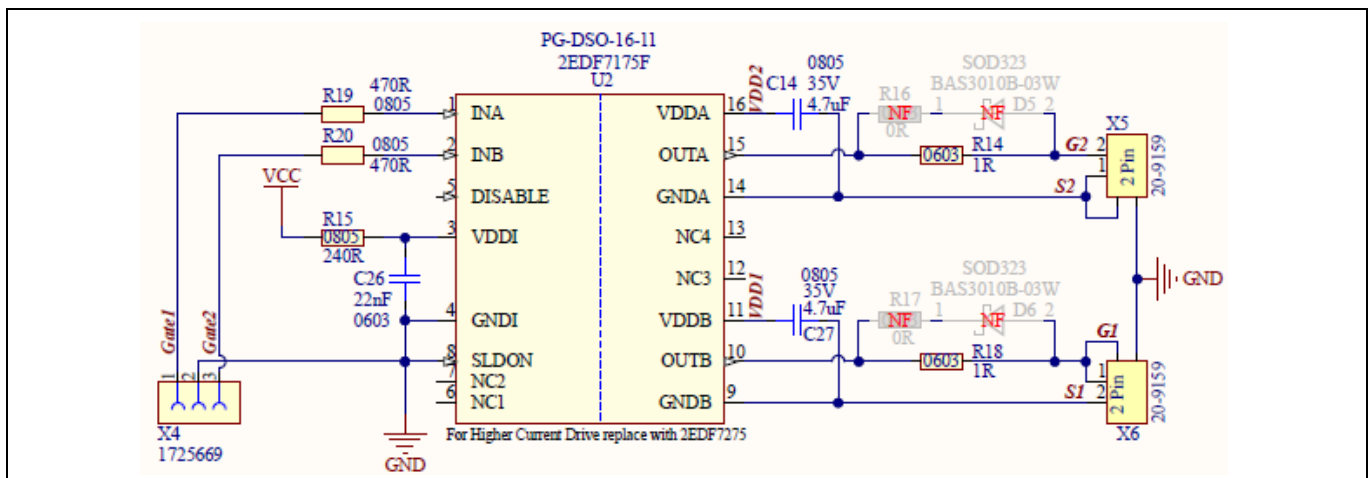

Figure 7 Gate driver schematic

Typically, the protection switches are driven by dedicated drivers that can drive the MOSFET's gate with currents in the range of less than 200 mA.

EVAL_BDPS_DRIVER board is used to drive the MOSFETs on EVAL_BDPS_DD_TOLL/G boards. It is designed by using **2EDF7175F**, a two-channel isolated gate driver. Both output channels are individually isolated with very high 150 V/ns common mode noise immunity (CMTI). Each channel can drive the MOSFETs with 1 A source and 2 A sink currents, thereby it allows the designer to evaluate the MOSFETs in parallel configuration.

An isolated DC-DC converter is employed on the board that supplies the input and output channels of the gate driver with the necessary voltages. It is designed to support the following specification:

Table 2 Board specification

Specification	Values
Bias voltage across X1	15 to 75 V DC
Gate driver	2EDF7175F functional isolated driver
Gate signals across X4	2.5 to 12 V
Output current	2.0 (sink)/1.0 A (source) maximum
Board size	47 x 24 mm

4 Board setup

4.1 Interfacing the boards

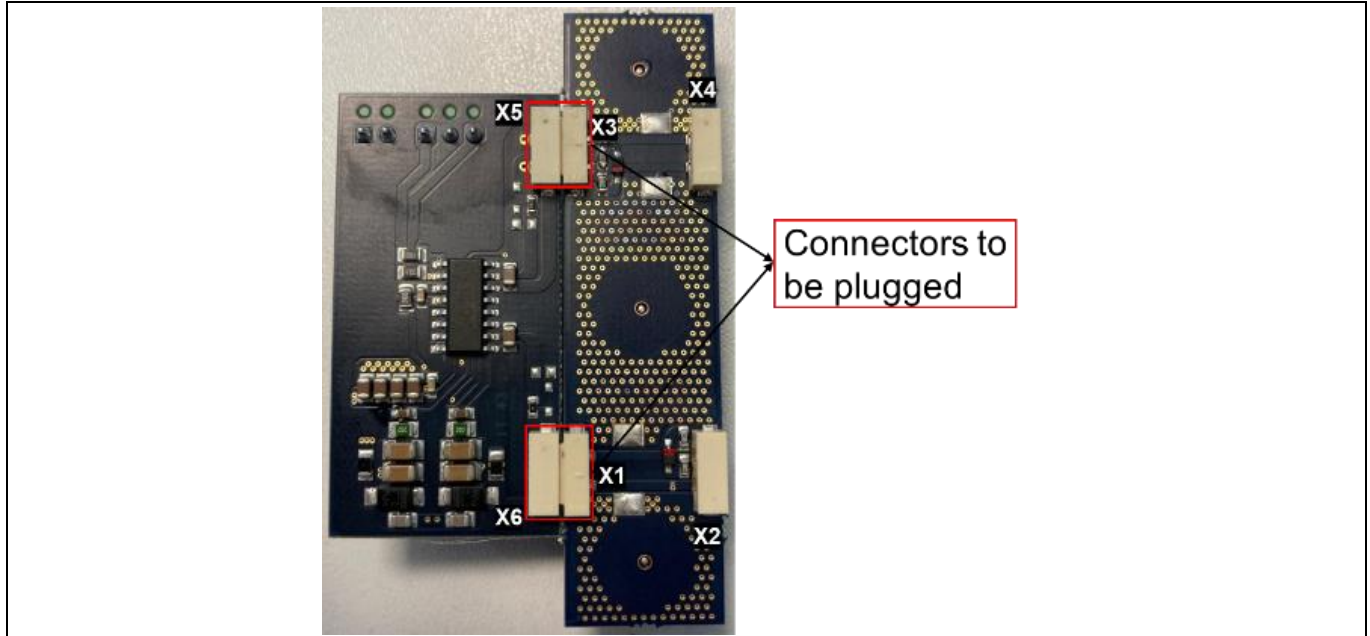

Figure 8 Interfacing boards

The gate driver board must be interfaced with the EVAL_BDPS_DD_TOLL/G to drive the MOSFETs. Connectors to interface the boards are mounted on the bottom side of both PCBs. As shown in **Figure 8**, connectors on the gate driver board are designated as X5 and X6. Similarly, on the EVAL_BDPS_DD_TOLL/G they are designated as X1 and X3. Plug the male connector (X1 and X3) available on EVAL_BDPS_DD_TOLL/G with the EVAL_BDPS_DRIVER board to drive the MOSFET gates.

4.2 Connecting the boards with a battery or supply

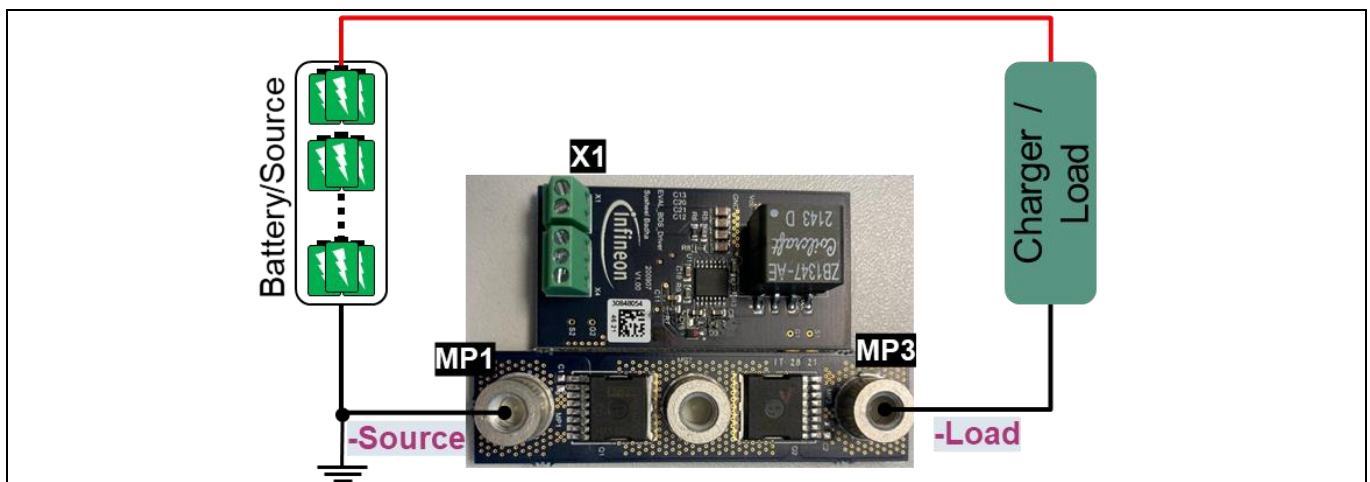

Figure 9 Connecting the EVAL_BDPS_DD_TOLL/G with source and load

The MP1 and MP3 terminals on the bidirectional switch are used to interface with the source and load terminal. The battery/source and load/charger interface with the EVAL_BDPS_DD_TOLL/G is as shown in **Figure 9**; MP1 is used to connect with the source negative terminal and MP2 to connect with the load negative terminal.

Note:

1. Terminals MP1 and MP2 on the EVAL_BDPS_DD_TOLL/G can be interchangeable.
2. MOSFET gates are driven by an isolated gate driver. Thus, it is also possible to connect the MOSFETs on positive terminal of source or load.

4.3 Powering the gate driver board

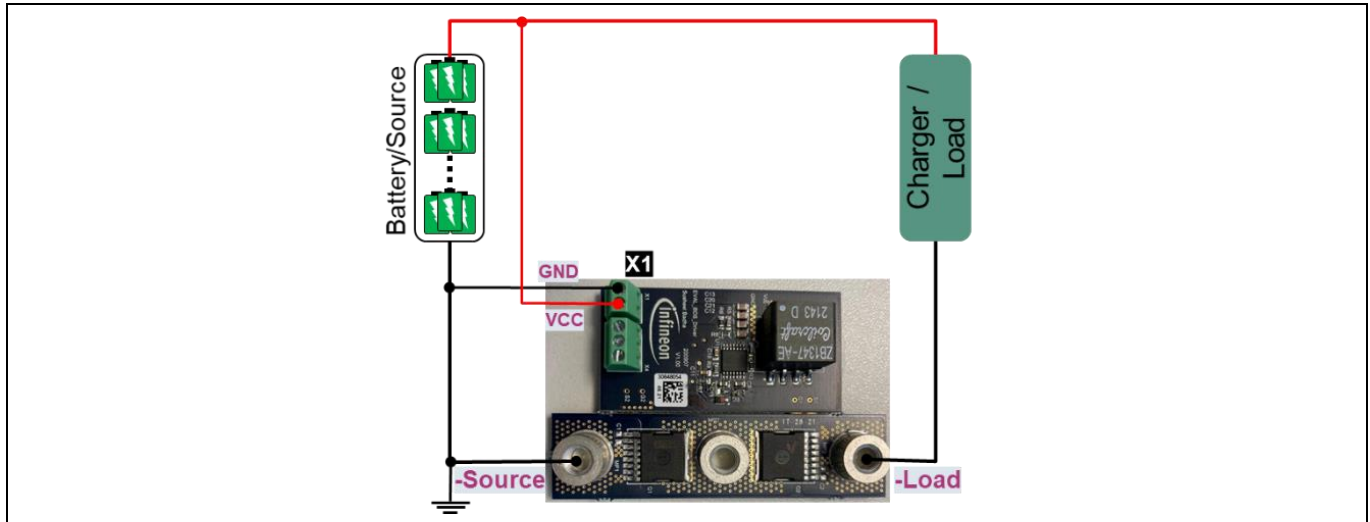

Figure 10 Powering the gate driver board with battery/source

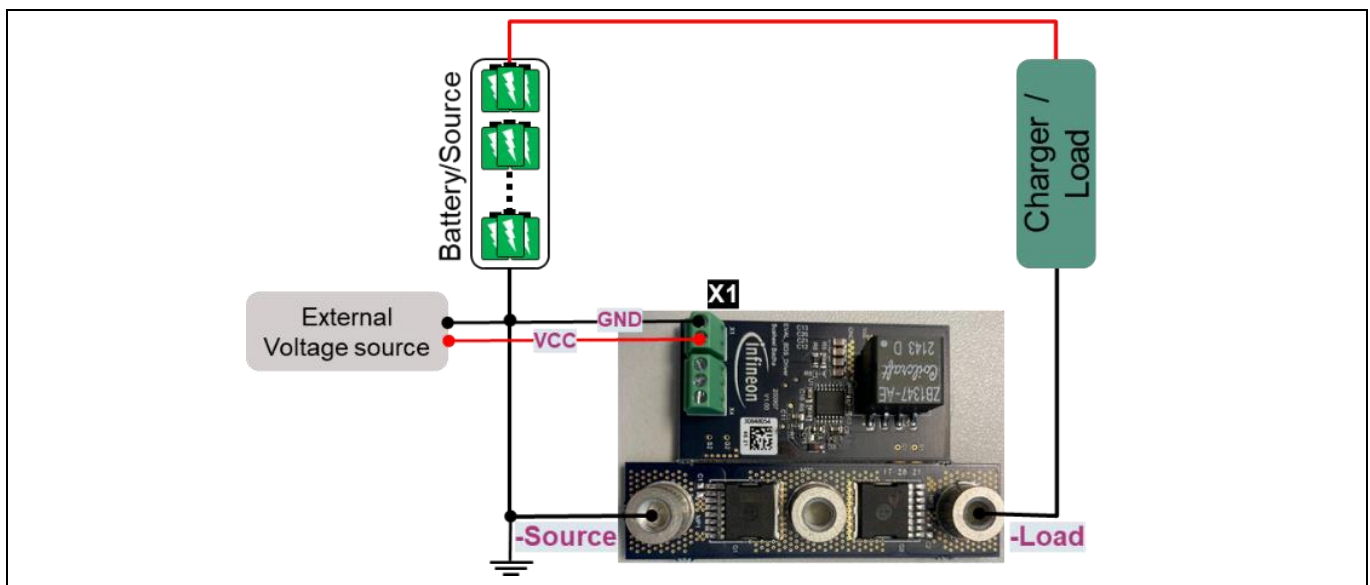

Figure 11 Powering the gate driver board with external source

The driver board can be powered in two different ways:

1. **Battery or source:** As shown in [Figure 10](#), connect pin 2 of the X1 connector on the gate driver board with the battery positive terminal and pin 1 to the battery negative terminal.
2. **External power supply:** As shown in [Figure 11](#), an external power supply voltage between 20 to 80 V is used. Connect pin 2 of the X1 connector on the gate driver board with the positive terminal of the external power supply and pin 1 to the ground of the external power supply. Additionally, connect the external power supply's ground with the battery's negative terminal.

Attention: *The power board is designed for a maximum of 80 V. There is no protection for the gate driver board. For this reason, pay attention to the supply polarity across pins 1 and 2 to the connector X1.*

4.4 Supplying gating signals to the gate driver board

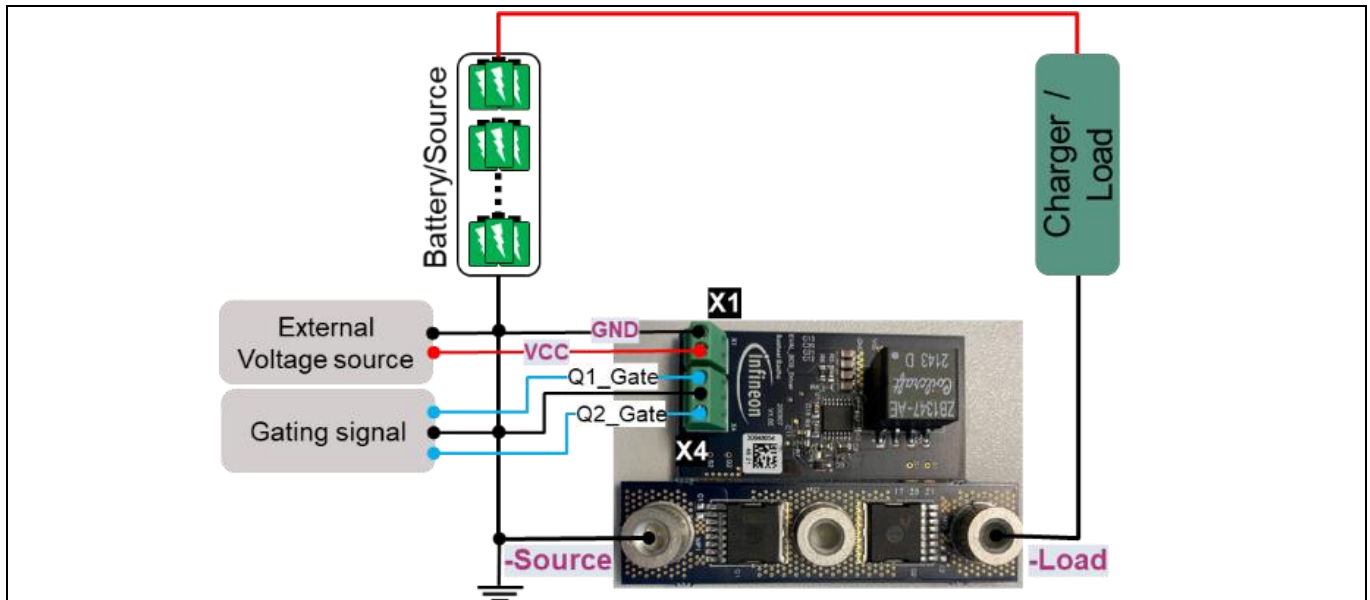

Figure 12 Supplying gating signals to the gate driver board

Connector X4 on the gate driver board is dedicated to supplying the gating signals. As shown in Figure 7 gate driver schematic, pin 1 of the X4 is dedicated to apply the gating signal to the MOSFET Q1. Similarly, pin 3 is dedicated to apply the gating signal to the MOSFET Q2.

Supply the 3.3 to 5 V gating signals to pin 1 and pin 3 with respect to pin 2 (ground) of the X4. The applied signal across X4 is connected to the input pins of the gate driver on board. Respectively, output channels of the gate driver are connected to the MOSFET to drive with currents based on gate resistances R1 and R2 selected on the EVAL_BDPS_DD_TOLL/G.

5 Paralleling the boards

The current drawn from each board is limited due to the temperature rise on the MOSFET on the board. It is recommended to limit the temperature rise of the MOSFETs to below 105°C. The bidirectional switch boards EVAL_BDPS_DD_TOLL/G can be connected in parallel by plugging in additional power boards allowing higher load currents. The number of boards required in parallel can be calculated by using the following equation.

$$\text{Number of boards in parallel} = I_L * \sqrt{\frac{R_{ds_on@100^\circ C} * R_{th_ja_6cm^2}}{T_{max} - T_{amb}}}$$

Where,

I_L : Load current

$R_{DS(on)}$ at 100°C : On-resistance of the MOSFET on EVAL_BDPS_DD_TOLL/G

$R_{th_JA_6\text{ cm}^2}$: Junction-to-ambient thermal resistance of the MOSFET on EVAL_BDPS_DD_TOLL/G

$T_{max.}$: Allowable maximum temperature on the MOSFET (recommended to limit it to less than 120°C)

T_{amb} : Ambient temperature

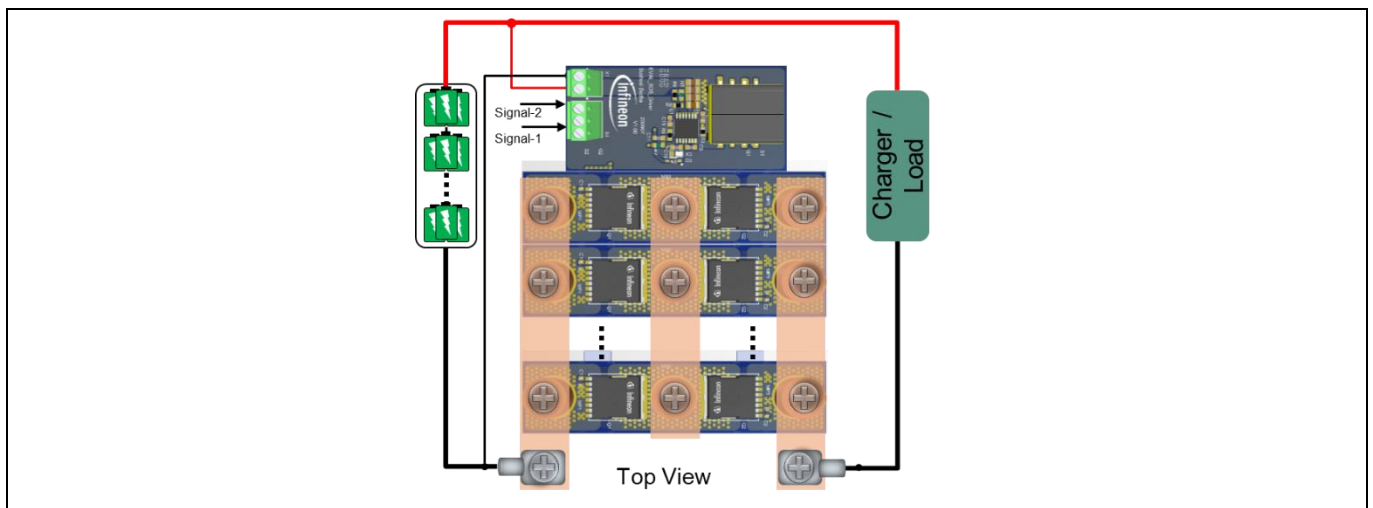

Figure 13 Top view of assembly with EVAL_BDPS_DD_TOLL/G connected in parallel

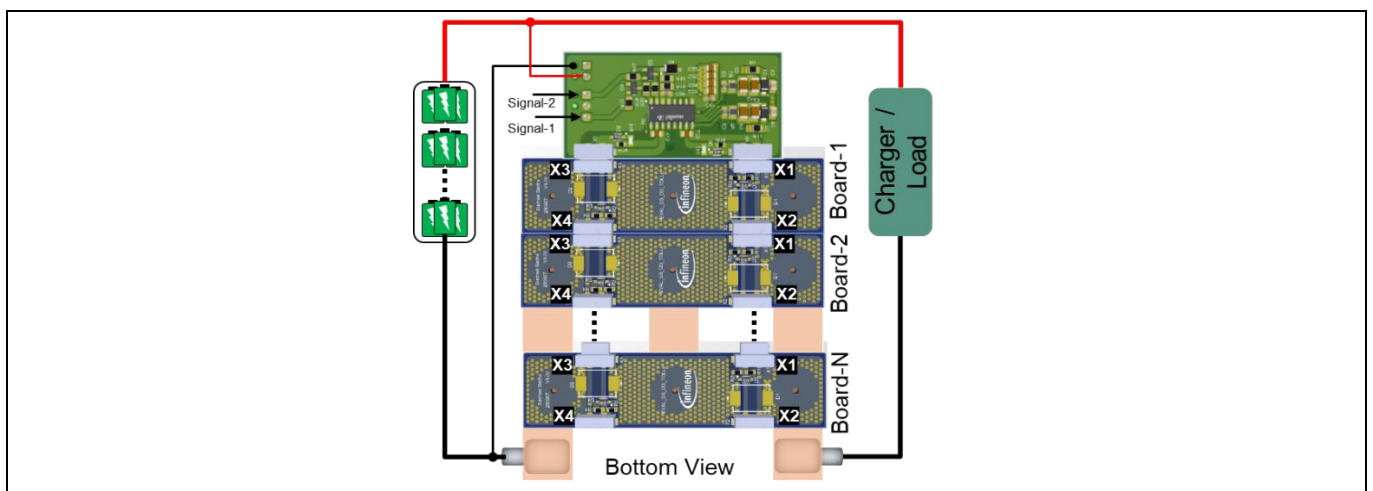

Figure 14 Bottom view of assembly with EVAL_BDPS_DD_TOLL/G connected in parallel

Paralleling the boards

Note: The maximum number of parallel power boards is limited by the gate driver and resistor R14, R16, R17 and R18 on the gate driver board.

By using the M5 screws and copper bus bar shown in [Figure 23](#) of the Appendix, screw all the terminals designated as MP1 on the boards to make a parallel connection. Similarly, screw a copper bus bar to connect all MP2 and MP3 terminals.

6 Protecting MOSFETs from avalanche

The voltage induced in parasitic inductance of the cable used to connect the bidirectional switch with the battery and load could lead the MOSFET into an avalanche, due to high turnoff slew rates (di/dt) of the MOSFET. The user can configure the gate resistors R3 and R4 on the EVAL_BDPS_DD_TOLL/G to adjust the turn-off slew rates by varying the resistors R3 and R4.

Additionally, the bidirectional protection switch board gives provision to mount TVS diodes D1 and D2 across MOSFETs. These diodes are not populated on the board, but the user can choose properly rated TVS diodes across drain to source to clamp the transient voltage across MOSFET drain and source.

Read more about the parasitic inductance effect in “Ensuring the Safe Operation of MOSFETs in Bidirectional Protection Power Switch (BDPS) Applications” [\[2\]](#).

7 Plugging the boards into the user circuit

Due to the small form factor, the EVAL_BDPS_DD_TOLL/G can be easily integrated into the user circuit, as shown in **Figure 15**.

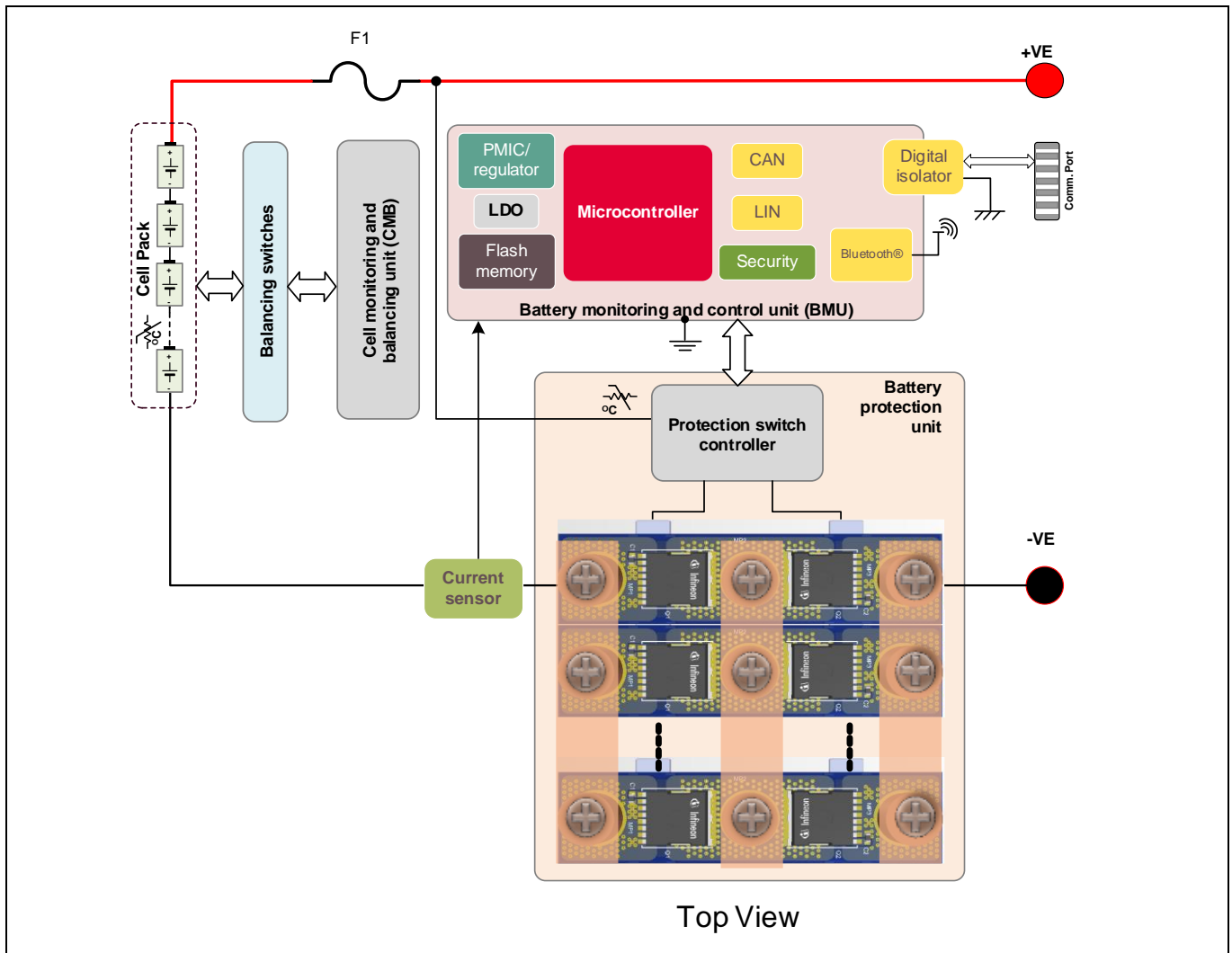

Figure 15 EVAL_BDPS_DD_TOLL/G in the user circuit

8 Test results

8.1 Test parameters

Table 3 lists the parameters for testing the boards.

Table 3 Parameters used to evaluate the boards

Specification	Variable	Value
Input voltage	V_{in}	50 V
Cable and parasitic Inductance	L_{loop}	1.5 μ H
Allowable maximum MOSFET temperature	T_{max}	100°C
Short-circuit current	I_{sc}	73 A
Duration of short-circuit current	t_{sc}	150 μ s

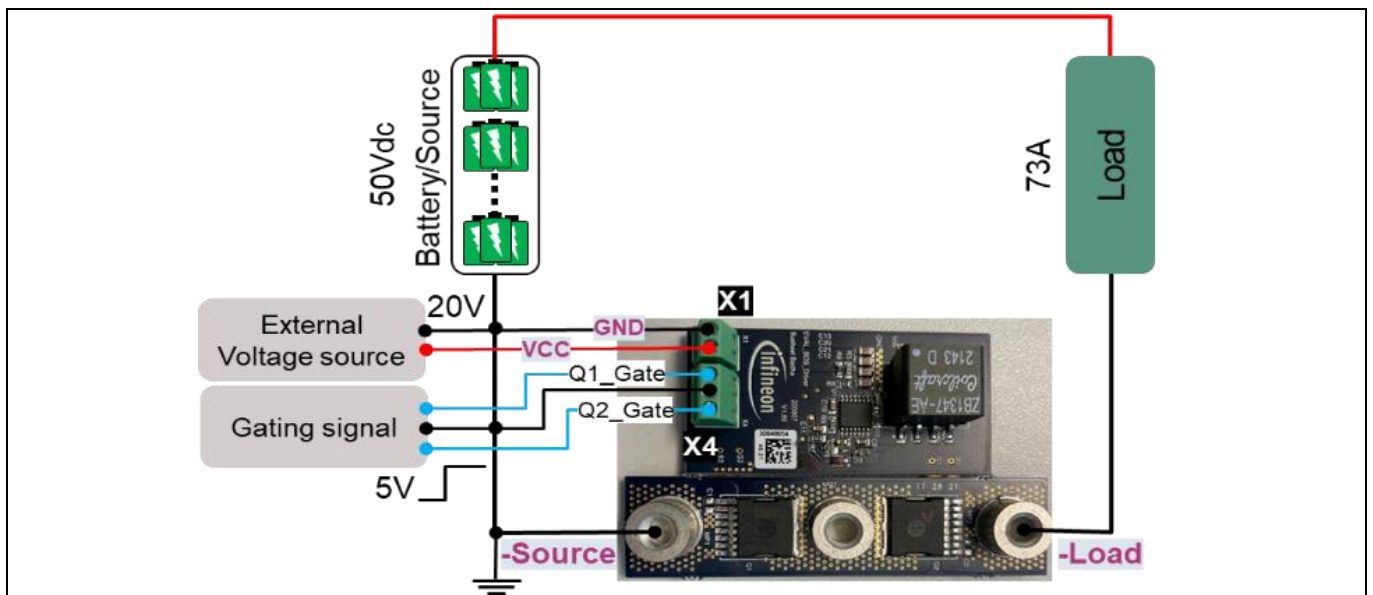

Figure 16 Test setup

8.2 Current vs. temperature measurement over time

At the continuous load current of 37 A the MOSFET temperature is 100°C. In this condition, the short-circuit of 73 A is applied. The test results are then obtained with [IPTG014N10NM5 \(TOLG\)](#) shown in [Figure 17](#) and [Figure 18](#). [IPT015N10N5 \(TOLL\)](#) will have a very similar performance to [IPTG014N10NM5](#).

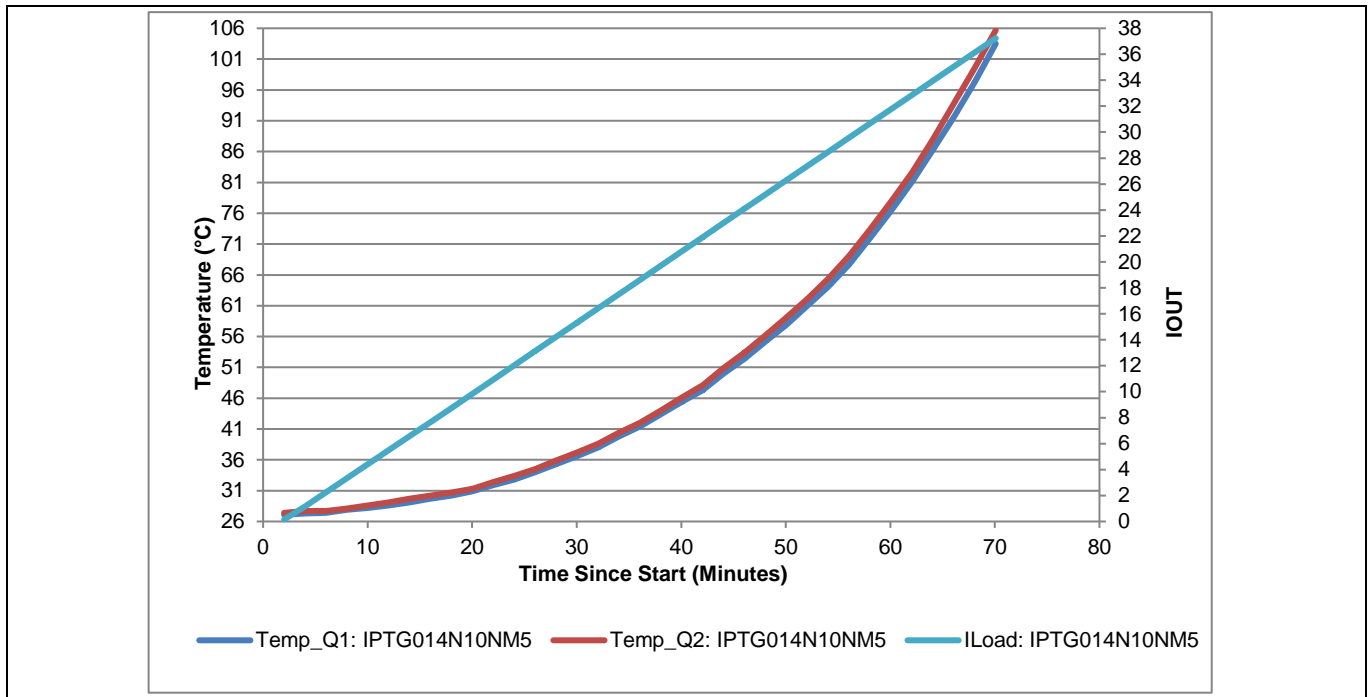

Figure 17 Current vs. temperature measurement over time

8.3 Waveforms

A short-circuit test was performed on IPTG014N10NM5 (TOLG). The result is shown in Figure 18. The TOLG IPT015N10N5 will have the same performance as IPTG014N10NM5 (TOLG).

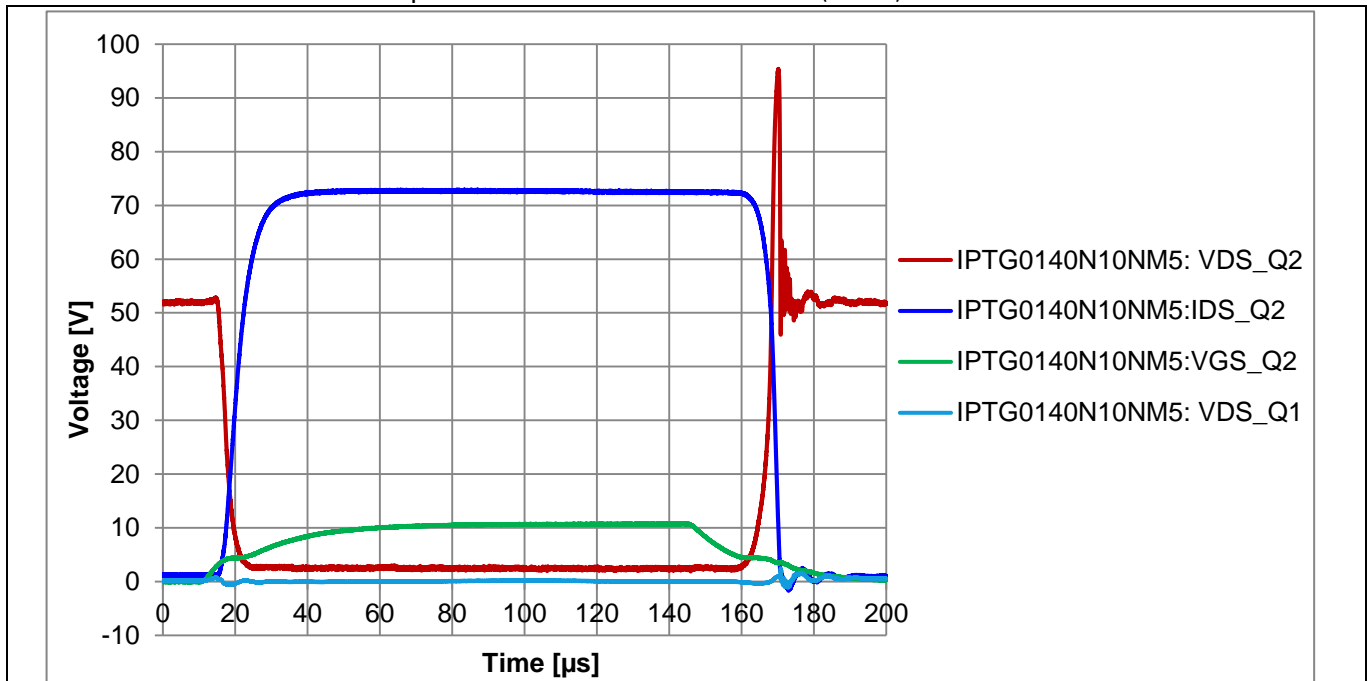

Figure 18 Waveforms with 73 A short-circuit current

9 Appendix

9.1 EVAL_BDPS_DD_TOLL/G (bidirectional switch board)

9.1.1 Schematic

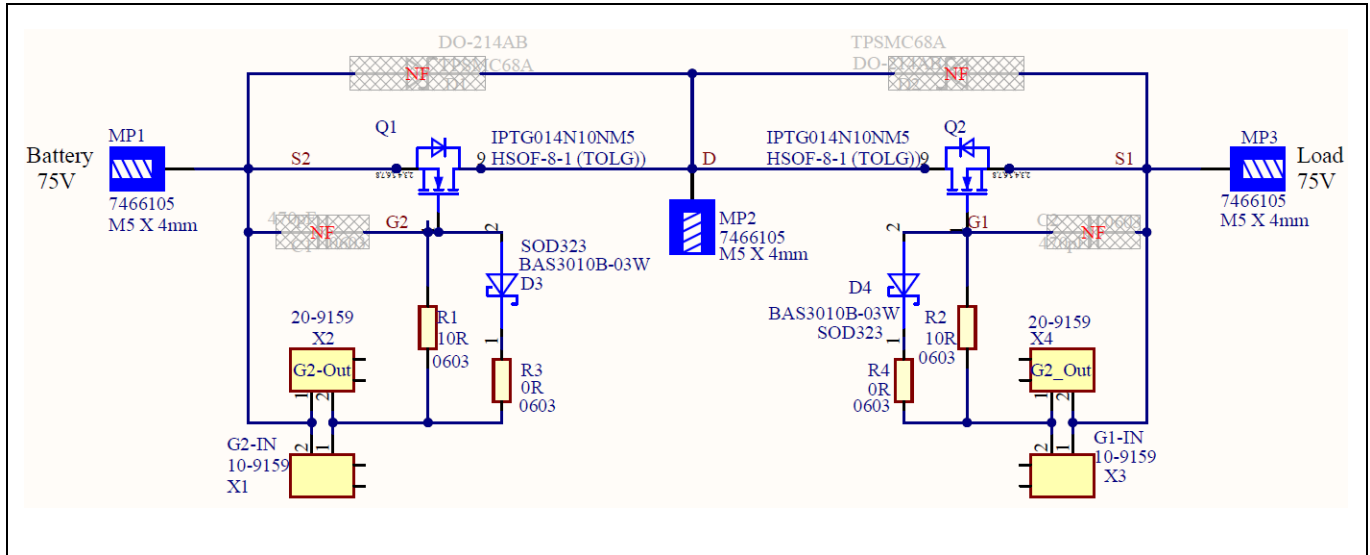

Figure 19 EVAL_BDPS_DD_TOLLG schematic

Note: The EVAL_BDPS_DD_TOLL schematic is the same as EVAL_BDPS_DD_TOLLG. Only MOSFETs Q1 and Q2 are replaced with IPT015N10N5.

9.1.2 Bill of materials

Table 4 Bill of materials

#	Qty.	Designator	Description	Package reference	Manufacturer	Manufacturer order number
1	2	D3, D4	Medium power AF Schottky diode	SOD323	Infineon Technologies	BAS3010B-03W
2	3	MP1, MP2, MP3	WP-SMBU SMT terminals	M5 X 4mm	Würth Elektronik	7466105
3	2	Q1, Q2	OptiMOS™ 5 power transistor, 100 V	PG-HSOF-8-1	Infineon Technologies	IPTG014N10NM5
4	4	R1, R2, R3, R4	Resistor/STD/1k/100 mW/1%/100 ppm/K/0603	0603	Yageo	RC0603FR-071KL
5	2	X1, X3	Board-to-board connector	10-9159	Murata Electronics	20915900210111 6
6	2	X2, X4	Board-to-board connector	20-9159	Murata Electronics	20915900210111 6

Note: The EVAL_BDPS_DD_TOLLG bill of materials is the same as EVAL_BDPS_DD_TOLL. Only MOSFETs Q1 and Q2 are replaced with IPTG014N10NM5 (package: INF-PG-HSOG-8-1-1-V).

9.1.3 Layout

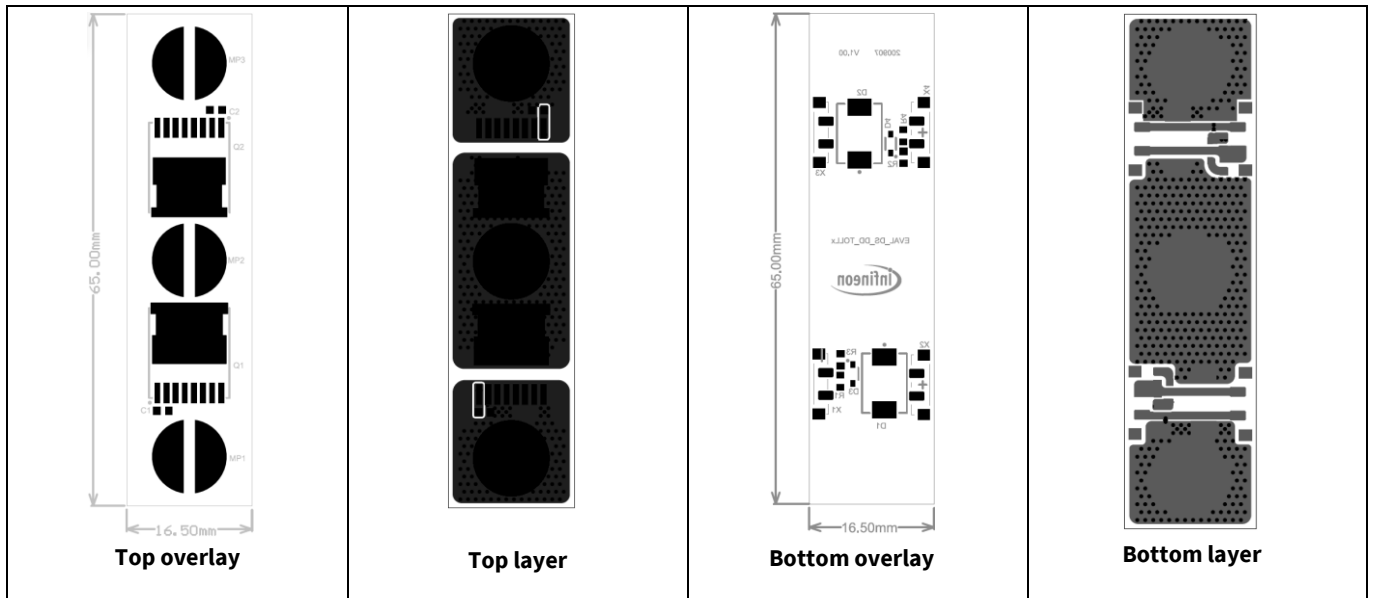

Figure 20 Layout

9.2 EVAL_BDPS_DRIVER (gate driver board)

9.2.1 Schematic

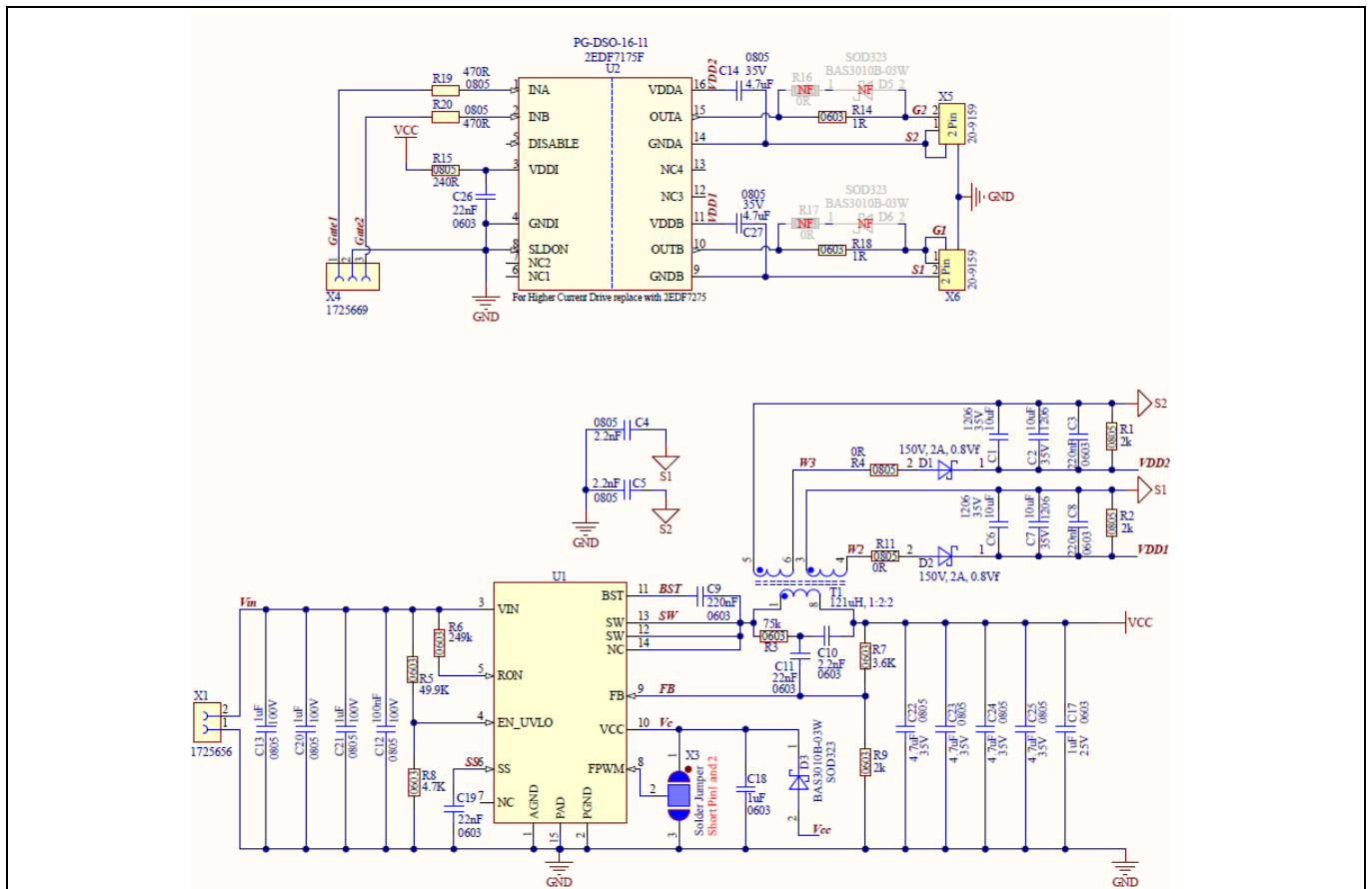

Figure 21 Gate driver schematic

9.2.2 Bill of materials

Table 5 BOM

#	Quantity	Designator	Value	Description	Package reference	Manufacturer	Manufacturer order number
1	4	C1, C2, C6, C7	10 μ F	10 μ F/25 V/10%/X7R	1206	Taiyo Yuden	GMK316AB7106KL-TR
2	3	C3, C8, C9	220 nF	100 nF/50 V/5%/X7R	0603	Vishay	VJ0603Y223JXACW1BC
3	2	C4, C5	2.2 nF	2.2 nF/250 V/10%/X7R	0805	TDK	C2012C0G2W222J085AE
4	1	C10	2.2 nF	2.2 nF/50 V/20%/X7R	0603	AVX	06035C222JAT2A
5	1	C11	22 nF	10 nF/50 V/5%/X7R	0603	Würth Elektronik	8.85012E+11
6	1	C12	100 nF	100 nF/100 V/10%/X7R	0805	Kemet-	C0805C224J1RECTU
7	3	C13, C20, C21	1 μ F	1 μ F/100 V/10%/X7S	0805	TDK Corporation	CGA4J3X7S2A105K125AB
8	6	C14, C22, C23, C24, C25, C27	4.7 μ F	4.7 μ F/25 V/10%/X7R	0805	TDK	CGA4J1X7R1V475K125AC
9	2	C17, C18	1 μ F	100 nF/50 V/5%/X7R	0603	Vishay, Murata	GCJ188R71E105KA01D
10	2	C19, C26	22 nF	22 nF/25 V/20%/X7R	0603	Yageo	CC0603JRX7R9BB223
11	2	D1, D2	150 V, 2A, 0.8 Vf	Schottky rectifier, 5 A/200 V	SOD-128/DO-221AC	Micro Commercial Components	755-RB068LAM150TFTR
12	1	D3	BAS3010B-03W	Schottky diode	SOD-323	Infineon Technologies	BAS3010B-03W
13	0	D5, D6	BAS3010B-03W	Schottky diode	SOD-323	Infineon Technologies	BAS3010B-03W
14	2	R1, R2	2k	2k/250 mW	0805	KOA Speer	RK73B2ATTD202J
15	1	R3	75k	75k/100 mW	0603	Vishay	ERJP03F7502V
16	2	R4, R11	0R	1.2R/125 mW	0805	Vishay	RCC08050000Z0EA
17	1	R5	49.9k	50k/100 mW	0603	Vishay	CRCW060349K9FKEB
18	1	R6	249k	249k/100 mW	0603	Vishay	CRCW0603249KFKEA
19	1	R7	3.6k	10k/100 mW	0603	Vishay	CRCW06033K60FK
20	1	R8	4.7k	5.6k/100 mW	0603	Vishay	CRCW06034K70FK
21	1	R9	2k	2k/63 mW	0603	Vishay	CRCW06032K00DHEAP
22	2	R14, R18	1R	1R/100 mW	0603	Vishay	CRCW06031R00FK
23	1	R15	240R	3k/125 mW	0805	Vishay	CRCW0805240RFK
24	0	R16, R17	0R	0R/100 mW	0603	TE Connectivity	CRG0603ZR
25	2	R19, R20	470R	470R/330 mW	0805	Vishay	CRCW0805470RFK
26	1	T1	121 μ H, 1:2:2	EP10, Isat:1.6 A	EP10	Würth Electronics	ZB1347
27	1	U1	LM5161	Wide-input 100 V, 1 A Synchronous buck/Fly-Buck™ converter	HTSSOP (14)	Analog Devices/Linear Technology	LM5161PWPR
28	1	U2	2EDF7175F	EiceDRIVER™, dual-channel isolated, reinforced, safe and functional and 1 A/2 A ISO driver, 4 V UVLO	PG-DSO-16-11	Infineon Technologies	2EDF7175F
29	1	X1	1725656	PCB terminal block, 2.54 mm pitch, 2 pins		Phoenix Contact	1725656
30	1	X3	Solder jumper	SMD solder jumper		Infineon Technologies	Solder jumper 3 pins V2
31	1	X4	1725669	PCB terminal block, 2.54 mm pitch, 3 pins		Phoenix Contact	1725669
32	2	X5, X6	2 pin	Board-to-board connector	20-9159	Murata Electronics	209159002101116

9.2.3 PCB layout

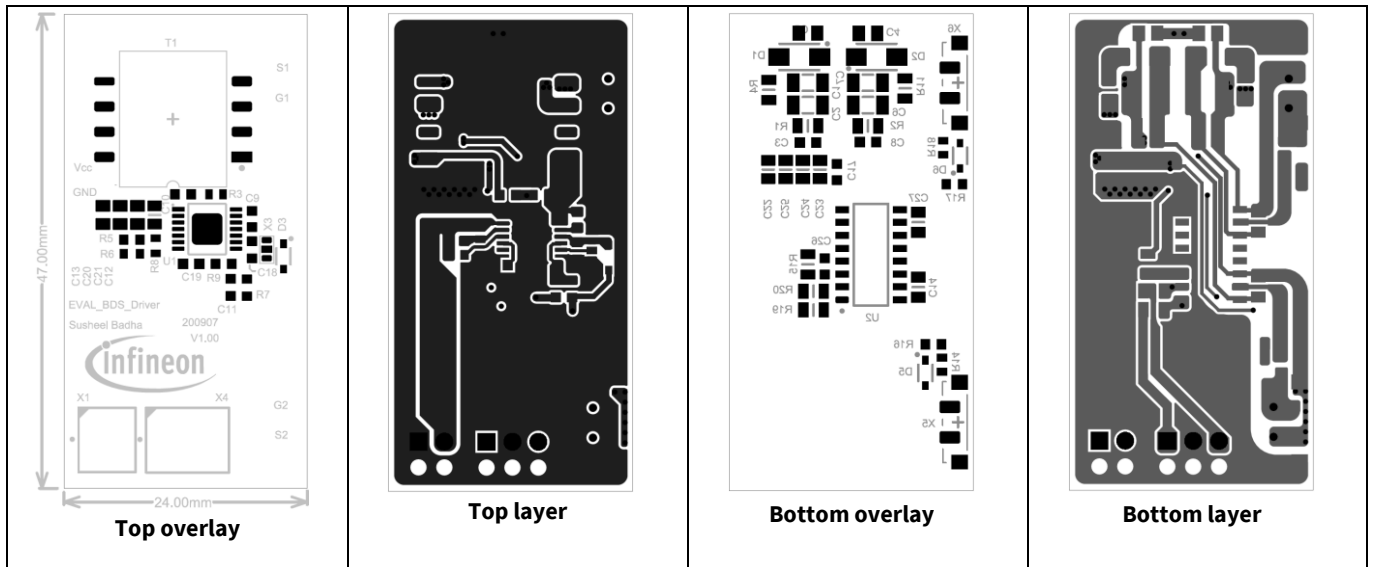

Figure 22 Gate driver PCB layout check

9.3 Copper bus bar dimensions

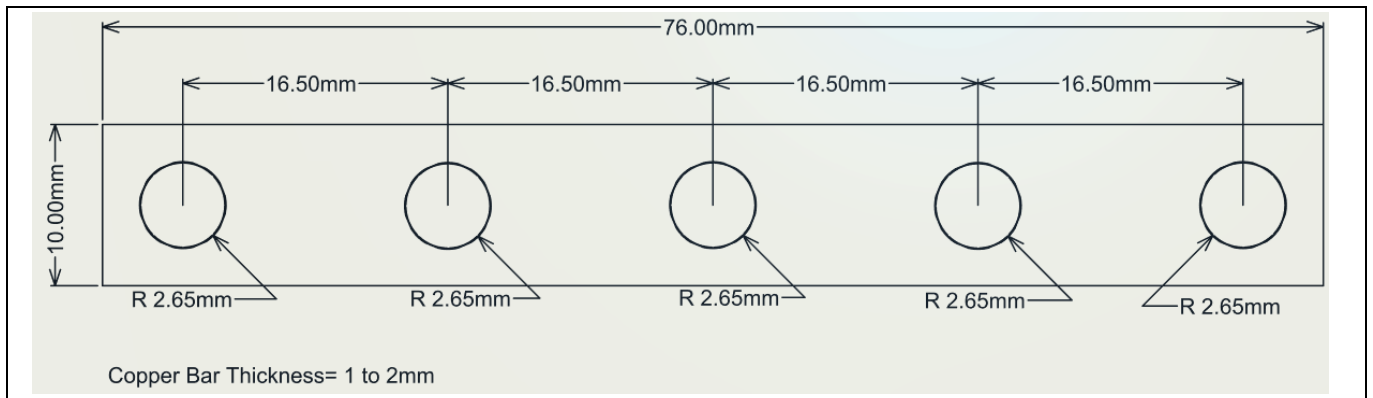

Figure 23 Copper bus bar dimensions

References

- [1] Infineon Technologies AG: Battery protection unit (BPU) – Infineon website; 2022; [available online](#).
- [2] Badha, Susheel/Ismail, Mahmoud: Service Robotics Advanced: Part 2 of 3. Editorial series sponsored by Infineon; Ensuring the Safe Operation of MOSFETs in Bidirectional Protection Power Switch (BDPS) Applications; Power Systems Design Edition 06/08/2021; [available online](#).

Revision history

Document version	Date of release	Description of changes
V 1.0	2022-07-21	Initial release
V 1.1	2023-04-17	Updated figures 5 and 19

Trademarks

All referenced product or service names and trademarks are the property of their respective owners.

Edition 2023-04-17

Published by
Infineon Technologies AG
81726 Munich, Germany

© 2023 Infineon Technologies AG.
All Rights Reserved.

Do you have a question about this document?

Email: erratum@infineon.com

Document reference
UM_2105_PL51_2105_105859

IMPORTANT NOTICE

The information contained in this application note is given as a hint for the implementation of the product only and shall in no event be regarded as a description or warranty of a certain functionality, condition or quality of the product. Before implementation of the product, the recipient of this application note must verify any function and other technical information given herein in the real application. Infineon Technologies hereby disclaims any and all warranties and liabilities of any kind (including without limitation warranties of non-infringement of intellectual property rights of any third party) with respect to any and all information given in this application note.

The data contained in this document is exclusively intended for technically trained staff. It is the responsibility of customer's technical departments to evaluate the suitability of the product for the intended application and the completeness of the product information given in this document with respect to such application.

For further information on the product, technology, delivery terms and conditions and prices please contact your nearest Infineon Technologies office (www.infineon.com).

WARNINGS

Due to technical requirements products may contain dangerous substances. For information on the types in question please contact your nearest Infineon Technologies office.

Except as otherwise explicitly approved by Infineon Technologies in a written document signed by authorized representatives of Infineon Technologies, Infineon Technologies' products may not be used in any applications where a failure of the product or any consequences of the use thereof can reasonably be expected to result in personal injury.

X-ON Electronics

Largest Supplier of Electrical and Electronic Components

Click to view similar products for [Power Management IC Development Tools](#) category:

Click to view products by [Infineon](#) manufacturer:

Other Similar products are found below :

[EVB-EP5348UI](#) [DA9063-EVAL](#) [BQ24155EVM](#) [BQ25010EVM](#) [REG710EVM-5](#) [TPS54980EVM-022](#) [TPS65010EVM-230](#) [BQ24120EVM-001](#) [BQ24212EVM-678](#) [BQ3050EVM-001](#) [ISL9520EVAL1Z](#) [UCC3809EVM](#) [LM3691TL-1.2EV/NOPB](#) [SOT23-3EV-VREG](#) [SOT89-3EV-VREG](#) [TPS2458EVM](#) [TPS54229EEVM-056](#) [TPS54329EEVM-056](#) [MAX8556EVKIT](#) [MAX20012EVKIT#](#) [MAX15005AEVKIT+](#) [S6SBP203A8FVA1001](#) [TPS652510EVM](#) [STEVAL-ISA047V1](#) [ISL8502AEVAL1Z](#) [ISL8009AEVAL1Z](#) [TPS76901EVM-127](#) [FRDM-HB2001-EVM](#) [BM6208FS-EVK-001](#) [LM5115EVAL](#) [LP5900TL-2.5EV](#) [DRI0043](#) [7E.12.8.230.0002](#) [KITPF8100FRDMEVM](#) [NCP10671B05GEVB](#) [MAX20073EVKIT#](#) [EVB-EN6337QA](#) [AP3125AEV1](#) [NIV6350MT2GEVB](#) [XMCA1](#) [RD33771-48VEVM](#) [EVKT-MPM3695-10-A](#) [DEMO200W12VDCLLC](#) [SAMPLEBOXILD8150TOBO1](#) [MAX18066EVKIT#](#) [AP61100Z6-EVM](#) [AP62300WU-EVM](#) [KIT8020-CRD-8FF1217P-1](#) [KITPF8121FRDMEVM](#) [EV2174C-G-00A](#)