

EVAL-IHW25N140R5L

2 kW induction heating evaluation board with reverse conducting R5L IGBT

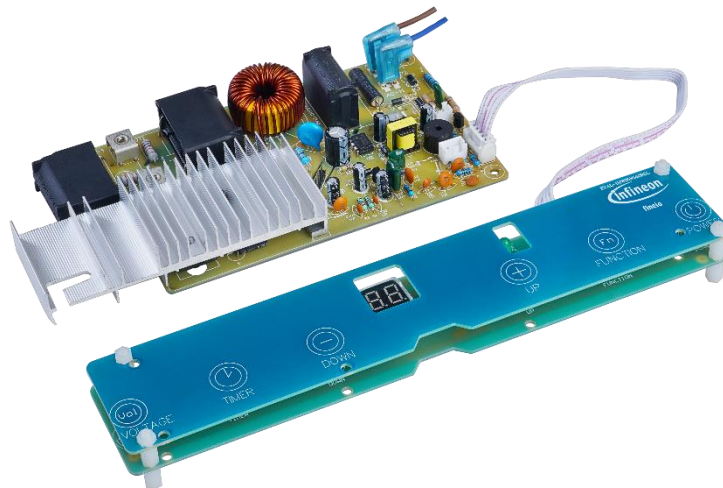

About this document

Scope and purpose

The induction heating, quasi-resonant board EVAL-IHW25N140R5L features the new 1400 V reverse conducting R5L IGBT. It is specifically designed for induction heating and resonant switching applications [1]. This user guide describes the functionality and key features of the evaluation board with R5L IGBT in combination with the 1ED4417xx family of Infineon EiceDRIVER™ [2] gate driver ICs.

Intended audience

- Engineers who want to learn how to use Infineon's reverse conducting IGBTs in combination with EiceDRIVER™ 1ED4417xx family
- Design engineers who design circuits with Infineon EiceDRIVER™ and/or RC IGBTs and who develop power electronic devices

Evaluation board

This board is to be used during the design-in process for evaluating and measuring characteristic curves, and for checking datasheet specifications.

Note: PCB and auxiliary circuits are NOT optimized for final customer design.

Important notice**Important notice**

“Evaluation Boards and Reference Boards” shall mean products embedded on a printed circuit board (PCB) for demonstration and/or evaluation purposes, which include, without limitation, demonstration, reference and evaluation boards, kits and design (collectively referred to as “Reference Board”).

Environmental conditions have been considered in the design of the Evaluation Boards and Reference Boards provided by Infineon Technologies. The design of the Evaluation Boards and Reference Boards has been tested by Infineon Technologies only as described in this document. The design is not qualified in terms of safety requirements, manufacturing and operation over the entire operating temperature range or lifetime.

The Evaluation Boards and Reference Boards provided by Infineon Technologies are subject to functional testing only under typical load conditions. Evaluation Boards and Reference Boards are not subject to the same procedures as regular products regarding returned material analysis (RMA), process change notification (PCN) and product discontinuation (PD).

Evaluation Boards and Reference Boards are not commercialized products, and are solely intended for evaluation and testing purposes. In particular, they shall not be used for reliability testing or production. The Evaluation Boards and Reference Boards may therefore not comply with CE or similar standards (including but not limited to the EMC Directive 2004/EC/108 and the EMC Act) and may not fulfill other requirements of the country in which they are operated by the customer. The customer shall ensure that all Evaluation Boards and Reference Boards will be handled in a way which is compliant with the relevant requirements and standards of the country in which they are operated.

The Evaluation Boards and Reference Boards as well as the information provided in this document are addressed only to qualified and skilled technical staff, for laboratory usage, and shall be used and managed according to the terms and conditions set forth in this document and in other related documentation supplied with the respective Evaluation Board or Reference Board.

It is the responsibility of the customer’s technical departments to evaluate the suitability of the Evaluation Boards and Reference Boards for the intended application, and to evaluate the completeness and correctness of the information provided in this document with respect to such application.

The customer is obliged to ensure that the use of the Evaluation Boards and Reference Boards does not cause any harm to persons or third party property.

The Evaluation Boards and Reference Boards and any information in this document is provided "as is" and Infineon Technologies disclaims any warranties, express or implied, including but not limited to warranties of non-infringement of third party rights and implied warranties of fitness for any purpose, or for merchantability.

Infineon Technologies shall not be responsible for any damages resulting from the use of the Evaluation Boards and Reference Boards and/or from any information provided in this document. The customer is obliged to defend, indemnify and hold Infineon Technologies harmless from and against any claims or damages arising out of or resulting from any use thereof.

Infineon Technologies reserves the right to modify this document and/or any information provided herein at any time without further notice.

Safety precautions

Safety precautions

Note: Please note the following warnings regarding the hazards associated with development systems

Table 1 Safety precautions

	<p>Warning: The DC link potential of this board is up to 1000 VDC. When measuring voltage waveforms by oscilloscope, high voltage differential probes must be used. Failure to do so may result in personal injury or death.</p>
	<p>Warning: The evaluation or reference board contains DC bus capacitors which take time to discharge after removal of the main supply. Before working on the drive system, wait five minutes for capacitors to discharge to safe voltage levels. Failure to do so may result in personal injury or death. Darkened display LEDs are not an indication that capacitors have discharged to safe voltage levels.</p>
	<p>Warning: The evaluation or reference board is connected to the grid input during testing. Hence, high-voltage differential probes must be used when measuring voltage waveforms by oscilloscope. Failure to do so may result in personal injury or death. Darkened display LEDs are not an indication that capacitors have discharged to safe voltage levels.</p>
	<p>Warning: Remove or disconnect power from the drive before you disconnect or reconnect wires, or perform maintenance work. Wait five minutes after removing power to discharge the bus capacitors. Do not attempt to service the drive until the bus capacitors have discharged to zero. Failure to do so may result in personal injury or death.</p>
	<p>Caution: The heat sink and device surfaces of the evaluation or reference board may become hot during testing. Hence, necessary precautions are required while handling the board. Failure to comply may cause injury.</p>
	<p>Caution: Only personnel familiar with the drive, power electronics and associated machinery should plan, install, commission and subsequently service the system. Failure to comply may result in personal injury and/or equipment damage.</p>
	<p>Caution: The evaluation or reference board contains parts and assemblies sensitive to electrostatic discharge (ESD). Electrostatic control precautions are required when installing, testing, servicing or repairing the assembly. Component damage may result if ESD control procedures are not followed. If you are not familiar with electrostatic control procedures, refer to the applicable ESD protection handbooks and guidelines.</p>
	<p>Caution: A drive that is incorrectly applied or installed can lead to component damage or reduction in product lifetime. Wiring or application errors such as undersizing the motor, supplying an incorrect or inadequate AC supply, or excessive ambient temperatures may result in system malfunction.</p>
	<p>Caution: The evaluation or reference board is shipped with packing materials that need to be removed prior to installation. Failure to remove all packing materials that are unnecessary for system installation may result in overheating or abnormal operating conditions.</p>



Table of contents

Table of contents

1

About this document..... 1

Important notice 2

Safety precautions..... 3

Table of contents..... 4

1 The board at a glance..... 5

1.1 Scope of supply6

1.2 Block diagram.....7

1.3 Main features7

2 System and functional description 8

2.1 Getting started.....8

2.2 Functional blocks and control description9

2.3 Basic operation of the board: an example 10

3 System design11

3.1 Schematics 11

3.2 Layout 12

3.3 Bill of material 14

3.4 Connector details 14

4 System performance15

4.1 Test points 15

4.2 Test results 17

Appendices21

Resonant load details 21

References 22

Revision history.....23

Disclaimer.....24

The board at a glance

1 The board at a glance

The EVAL-IHW25N140R5L induction heating board has been designed to reflect a typical induction cooking system. It features a 25 A 1400 V reverse conducting R5L IGBT driven by a 1ED4417xx gate driver. Controlled by an onboard microcontroller, this evaluation board offers rapid prototyping capabilities with automatic adjustment to operating conditions. The board is suitable for testing power semiconductor operation in systems based on the quasi-resonant topology.

The board has been tested with an input voltage of 220 V up to an output power of 2 kW. From AC mains, the auxiliary supply provides all necessary voltage levels for the control, driving, and miscellaneous circuitry.

The EVAL-IHW25N140R5L board comes with all the necessary passive components for operation. Figure 1 shows all connector location and their function on the board.

EVAL-IHW25N140R5L was designed based on the environmental conditions described in this document. The design was tested as described in this document, but is not qualified in terms of manufacturing, lifetime, or over the full range of ambient operating conditions. The boards provided by Infineon are not subject to full production tests.

Evaluation boards are not subject to the same procedures as regular products regarding returned material analysis (RMA), process change notification (PCN), and product discontinuation (PD). Evaluation boards are intended to be used under laboratory conditions, and by trained specialists only.

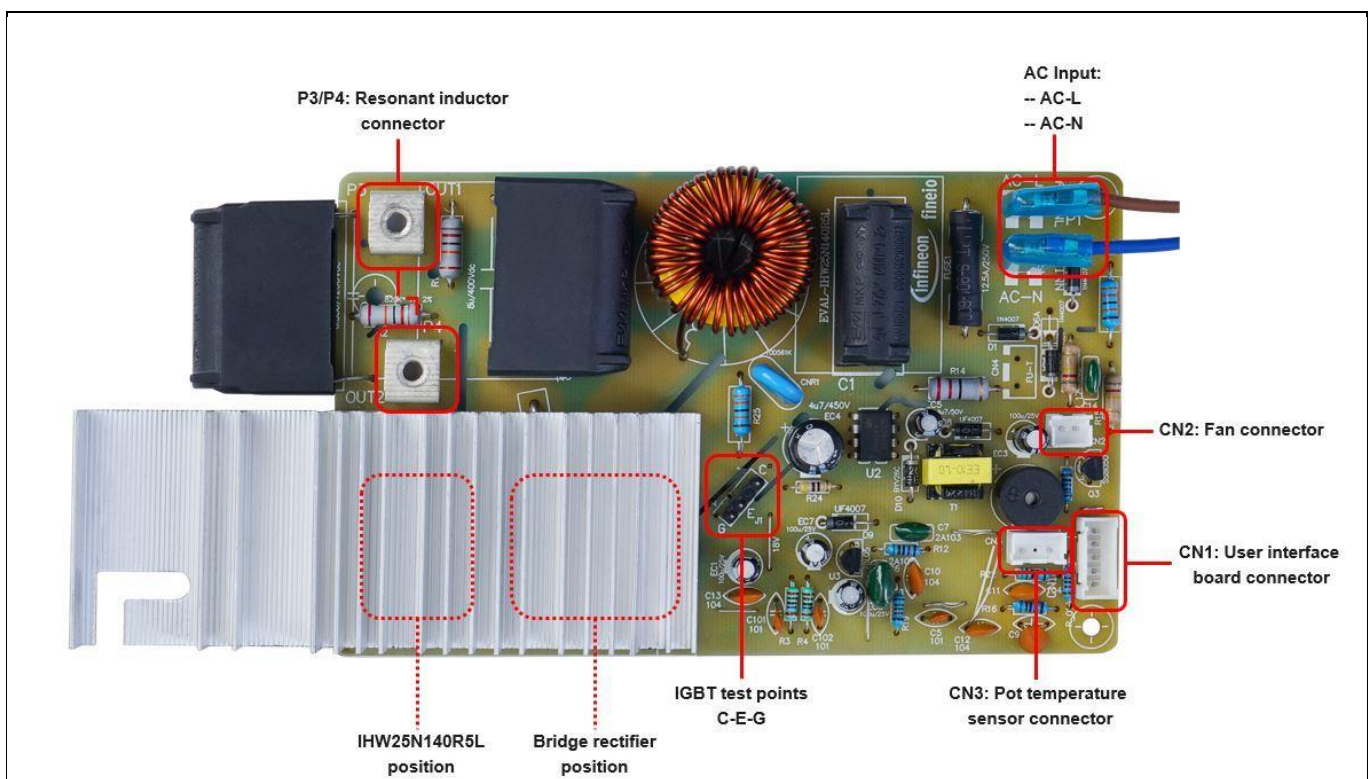

Figure 1 Quasi-resonant induction heating board

The board at a glance

1.1 Scope of supply

EVAL-IHW25N140R5L contains two printed circuit boards. The main board contains all power electronic parts of the inverter circuit while the second board is the user interface that allows control and changing of inverter operating conditions.

The evaluation board also contains a resonant coil that must be connected to the board. Users can connect different coils to the board to test different load variants. The electrical characterization of the evaluation board was done using the coil that comes in the original package.

Table 1 Delivery content

Item	Description	Quantity
EVAL-IHW25N140R5L inverter	Board contains all the power and auxiliary components of a quasi-resonant inverter	1
EVAL-IHW25N140R5L interface	Board with buttons for user control	1
Cooking coil	Typical cooking coil with sized inductance value for the resonant tank	1

1.2 Block diagram

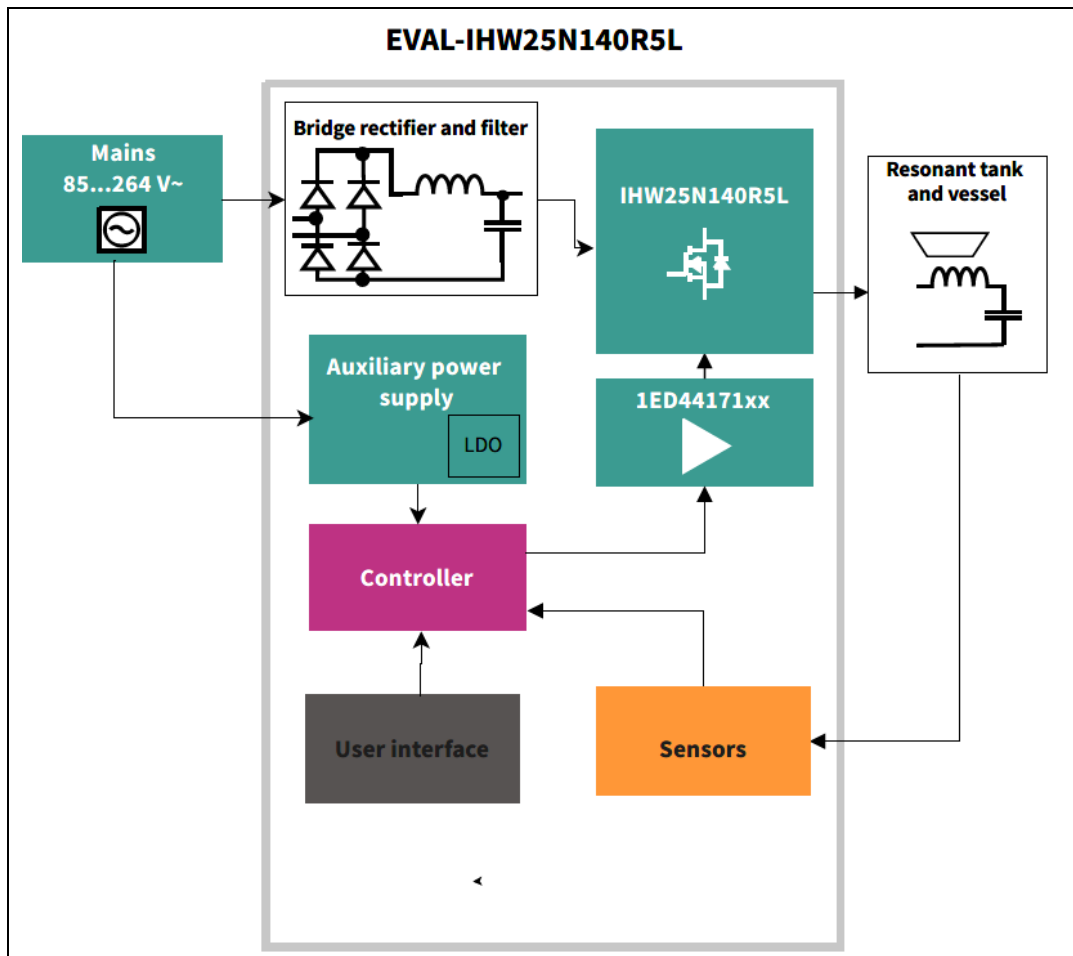

Figure 2 Block diagram of the evaluation board

Figure 2 shows a top-level overview of the induction heating board's building blocks. Detailed overview of a real board is shown in Figure 3.

1.3 Main features

The main features of the board are:

- Quasi-resonant topology
- 2 kW output power
- 9 levels of power control
- Overvoltage protection
- Undervoltage protection
- Overcurrent protection
- Overtemperature protection
- 99-minute timer functionality
- Isolated user interface

2 System and functional description

2.1 Getting started

Board setup

To set up the board for evaluation, follow these steps:

1. Connect the user interface board to CN1 (position of the first pin should be closer to the mounting hole).
2. Connect the fan to the 2-pin connector, CN2.
3. Connect the pot temperature sensor (part of the coil assembly) to the 3-pin connector, CN3.
4. Connect the resonant coil to the P3 and P4 screw terminals.
5. Connect the AC power source to the respective AC-L and AC-N terminal.

Note: Make sure all electrical connections are correct before powering up the board.

Note: During operation, a high voltage is present in the setup. Evaluation activities should, therefore, be done by experienced personnel.

If all the above steps are performed correctly, after applying a 220 V AC source on the user interface board, two LEDs together with a 7-segment display, will flash followed by a short sound signal. Status that everything is all right is indicated by the LED on the top being ON.

Recommended shutdown procedure

If the board is operating under normal conditions without electrical failure, users can stop it, if they want to, through several ways – by pressing the Power button, by turning off the AC supply, or by pressing the Function button. The correct approach is to press the Function button. Here, the power transfer stops but the auxiliary part of the board remains active and the fan continues cooling the IGBT and rectifier down. Using the other two methods interrupts the whole power supply and the heatsink remains at a high temperature from the operation.

2.2 Functional blocks and control description

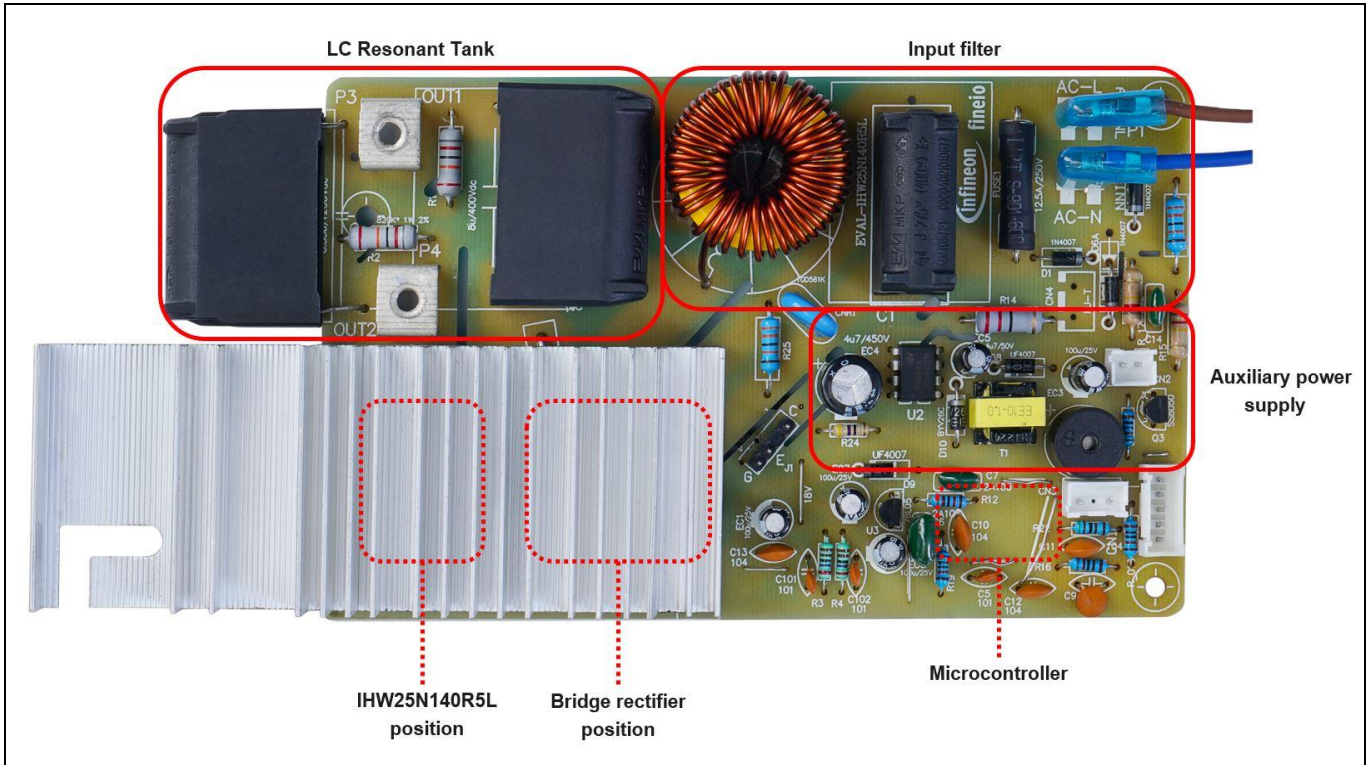

Figure 3 Quasi-resonant board: building blocks

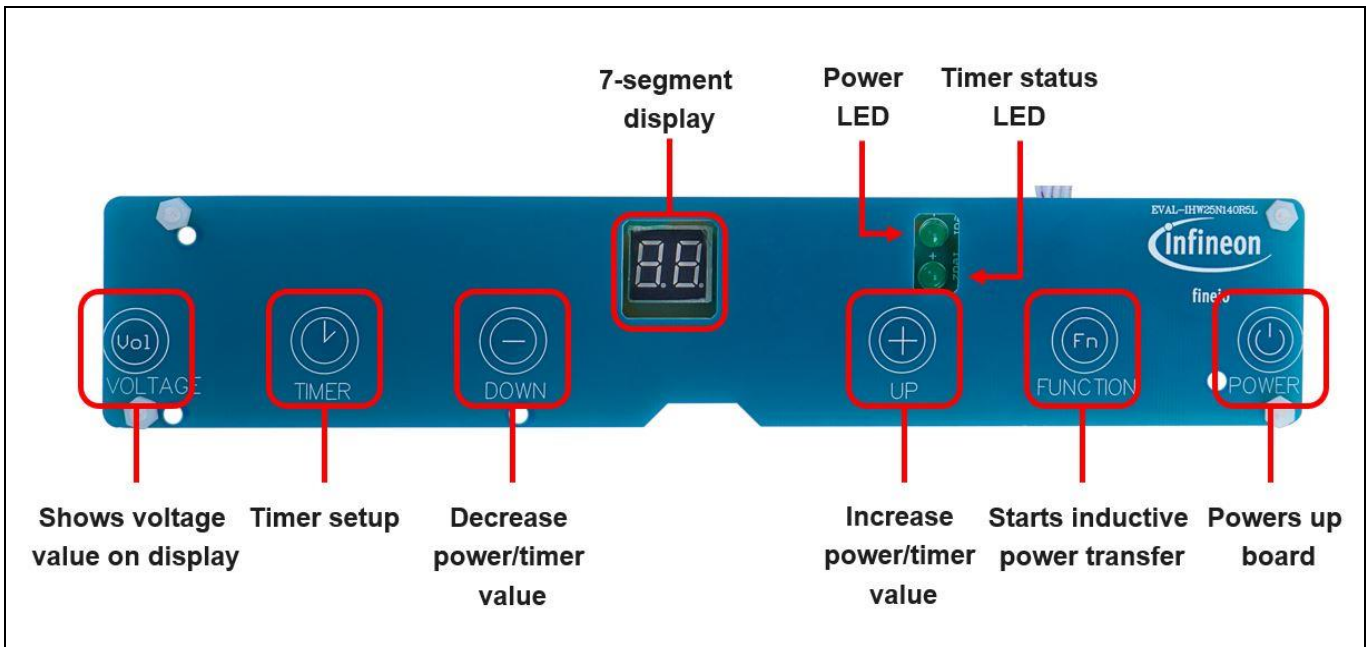

Figure 4 User interface board: control functions explanation

2.3 Basic operation of the board: an example

1. Press the Power button. Two dashes “- -” will flash on the 7-segment display indicating that all auxiliary parts of induction board are turned on. Inductive power transfer does not happen at this stage.
2. Press the Function button to start the power transfer at the highest power level, P9, which is equivalent to 2 kW output.
3. Press the Up and Down buttons to adjust the output power level in the range of P1 to P9. Every power level represents a difference of 200 W in the output value.
4. Use the Timer button to set a time after which the induction board should stop operating automatically. When the Timer button is pressed, the LED at the bottom lights up. In the timer mode, the Up and Down buttons can be used to set the time.
5. The Voltage button shows the voltage level on the 7-segment display.

3 System design

3.1 Schematics

Complete schematics are available in a PDF format on the evaluation board’s webpage under the Design Support section. Login credentials are required to download this material.

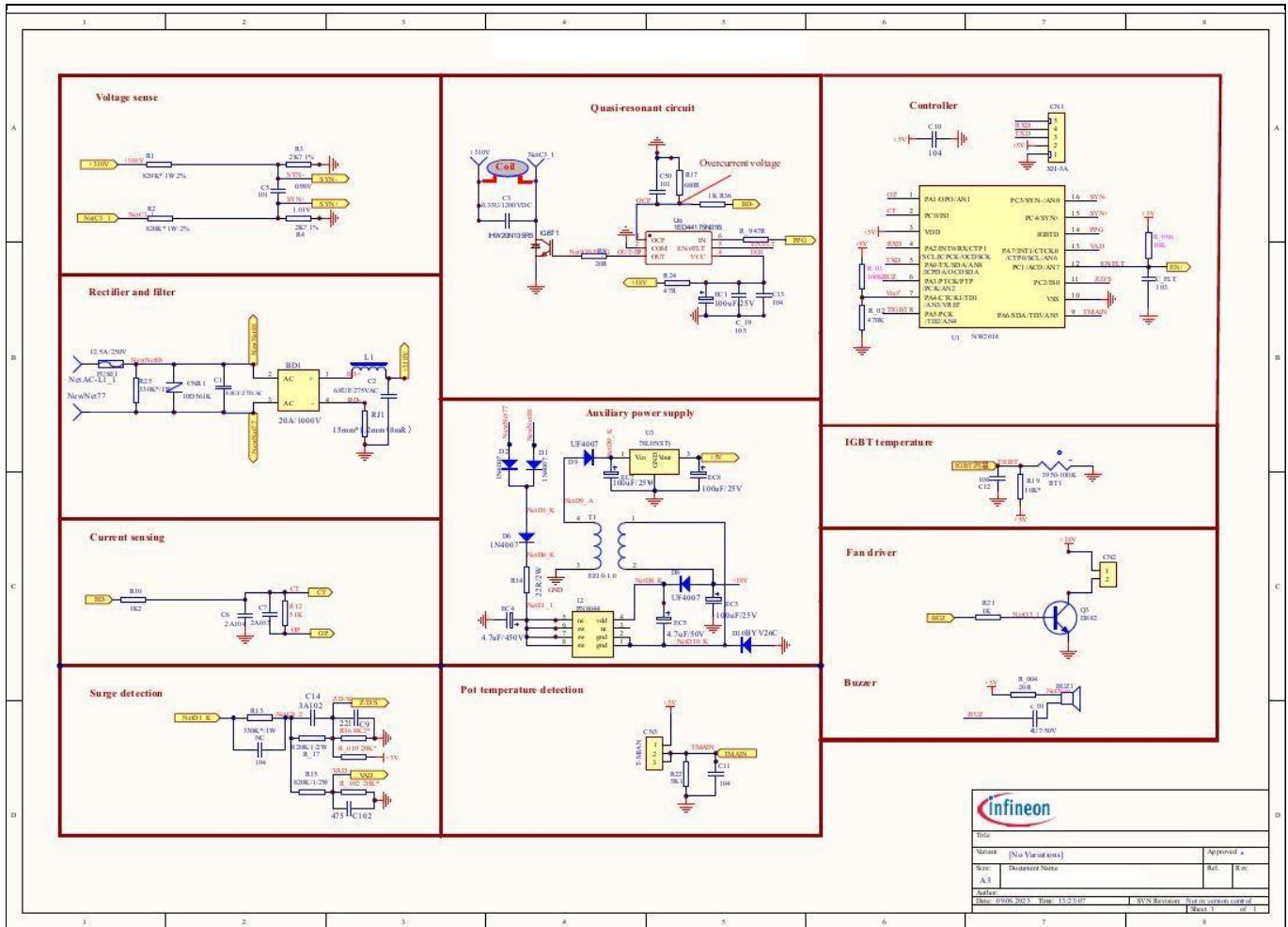

Figure 5 Schematic of the quasi-resonant power board

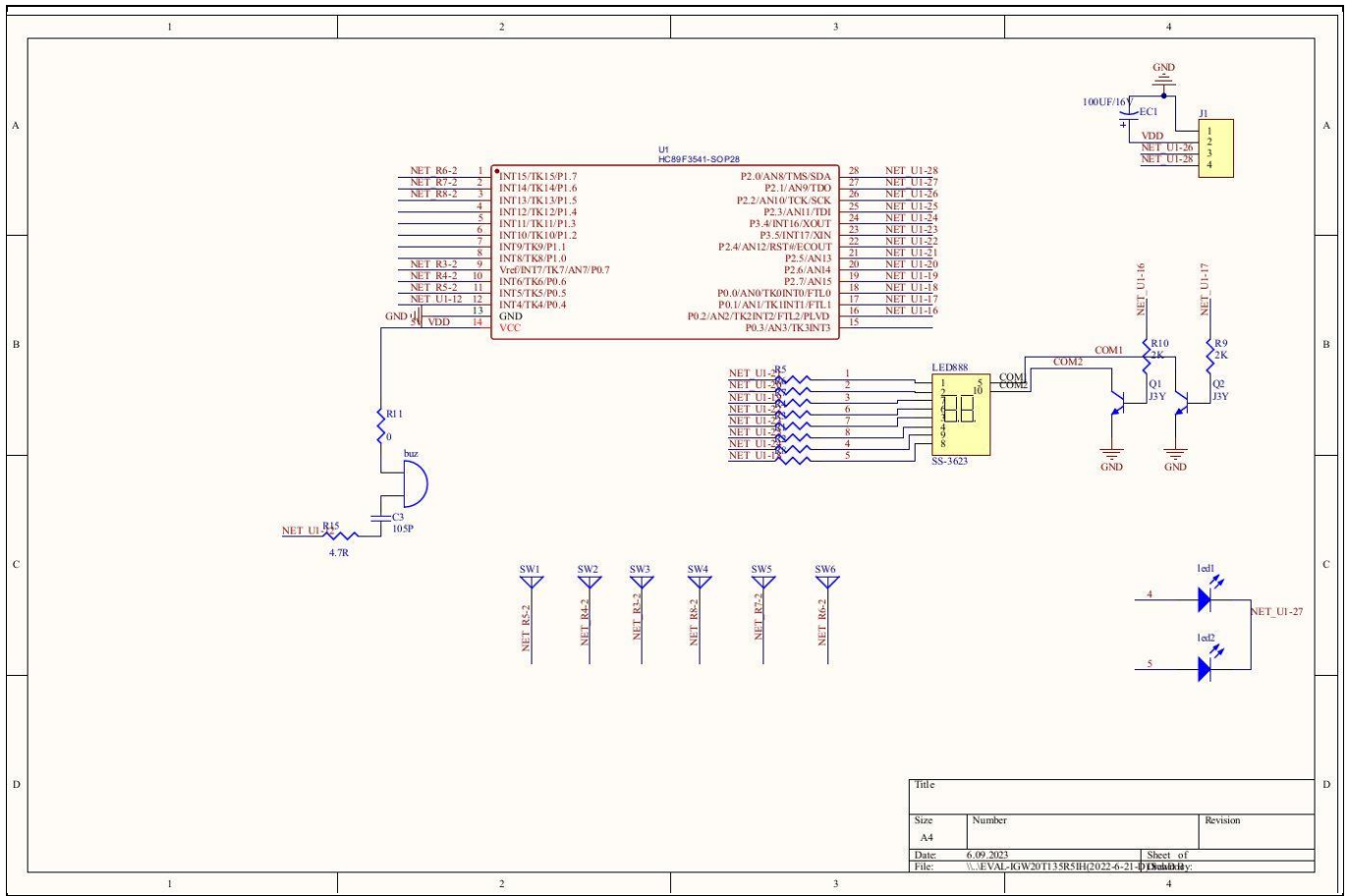

Figure 6 Schematic of the user interface board

3.2 Layout

Table 2 Printed circuit board layout parameters

Parameter	Value
Board dimensions: Inverter board	145 mm x 90 mm
Interface board	235 mm x 45 mm
Number of layers	1
Layer thickness	35 μm
Final board thickness	1.6 mm
PCB material	FR4

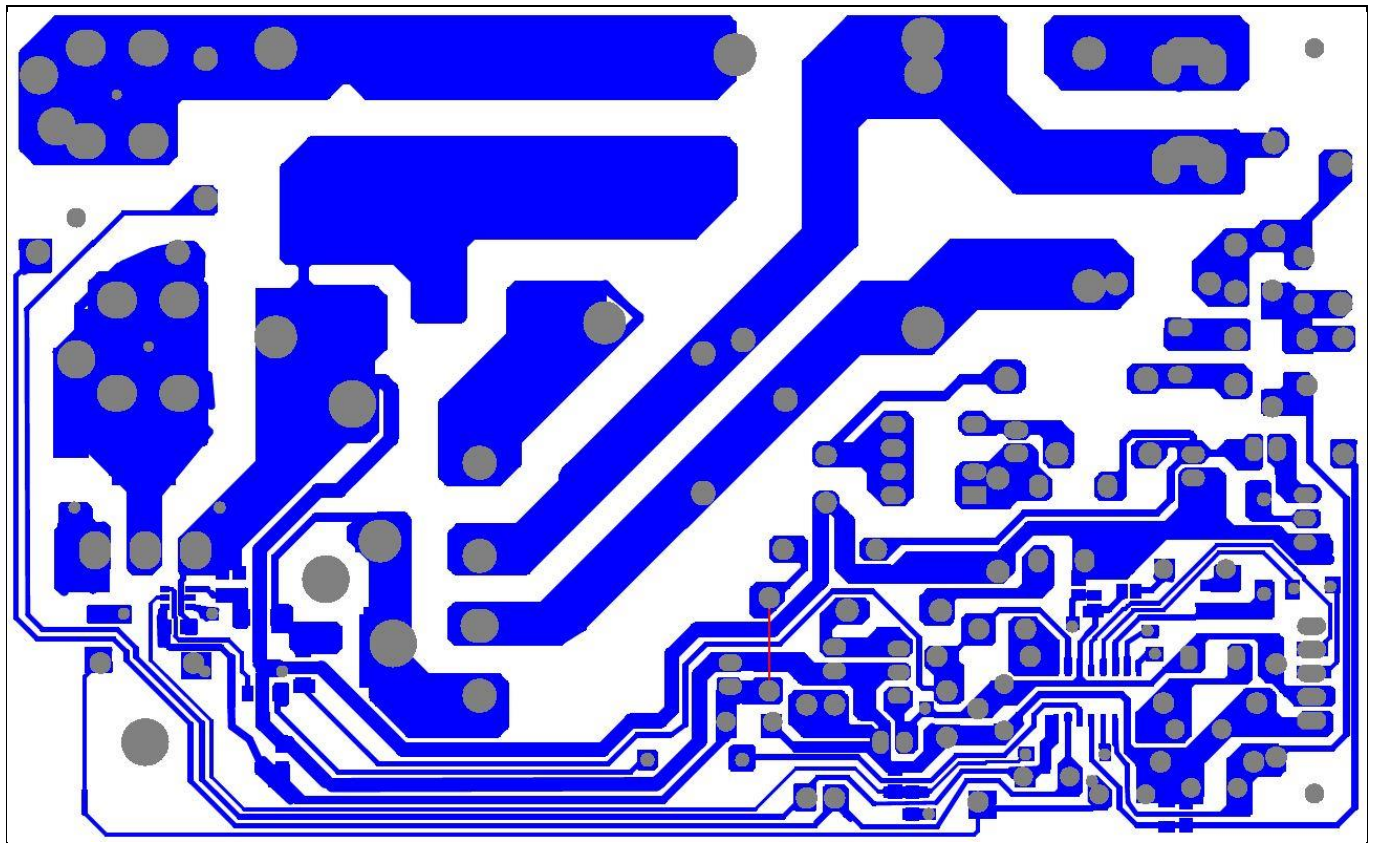

Figure 7 Layout of the quasi-resonant power board

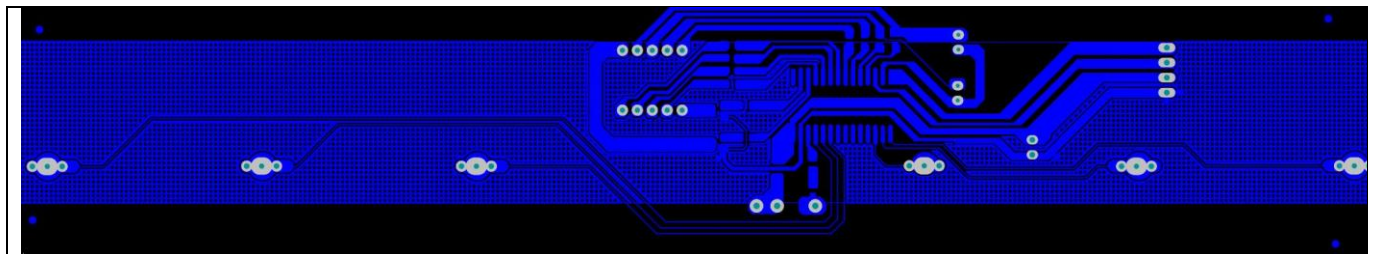

Figure 8 Layout of the user interface board

3.3 Bill of material

Complete bill of material (BOM) is available on the evaluation board's webpage under the Design Support section. Login credentials are required to download this material.

Table 3 BOM of the most important/critical parts of the evaluation board

Quantity	Designator	Description	Manufacturer	Manufacturer P/N
1	C3	0.33uF/1200Vdc(630Vac) J Black and vertical W:35*T:15*H:26mm, P=30.5mm, L=15mm	Fengming	PSB2123330KHSD
1	IGBT1	IGBT transistors IGBT PRODUCTS TrenchStop RC	Infineon	IHW25N140R5L
1	U1	Microcontroller	Holtek	NW2018
1	U2	AC/DC PFM converter	CHIPOWN	PN8044
1	Uo	Gate drivers LOW SIDE DRIVERS	Infineon	1ED44175N01BXTSA1

3.4 Connector details

Table 4 Connectors description

PIN	Label	Function
1	AC-L	AC supply phase line
1	AC-N	AC supply neutral line
4	CN1	User interface board connector
2	CN2	Fan connector
3	CN3	Pot temperature sensor connector
1	P3	Resonant coil connector
1	P4	Resonant coil connector

4 System performance

4.1 Test points

The EVAL-IHW25N140R5L induction heating board is suitable for real application use case testing. To properly acquire data from the evaluation test please follow the recommendations for connecting probes to the board.

All three terminals of the IGBT have exposed test points (Figure 9) for easy voltage measurement. The pins allow an easy connection to the collector (C), gate (G), and emitter (E) of the power switch. The IGBT waveforms should be measured with respect to the emitter pin. To obtain collector-emitter voltage using a high voltage probe with an attenuation of 100x or more is recommended. The gate signal of the power switch can be measured using a low voltage probe.

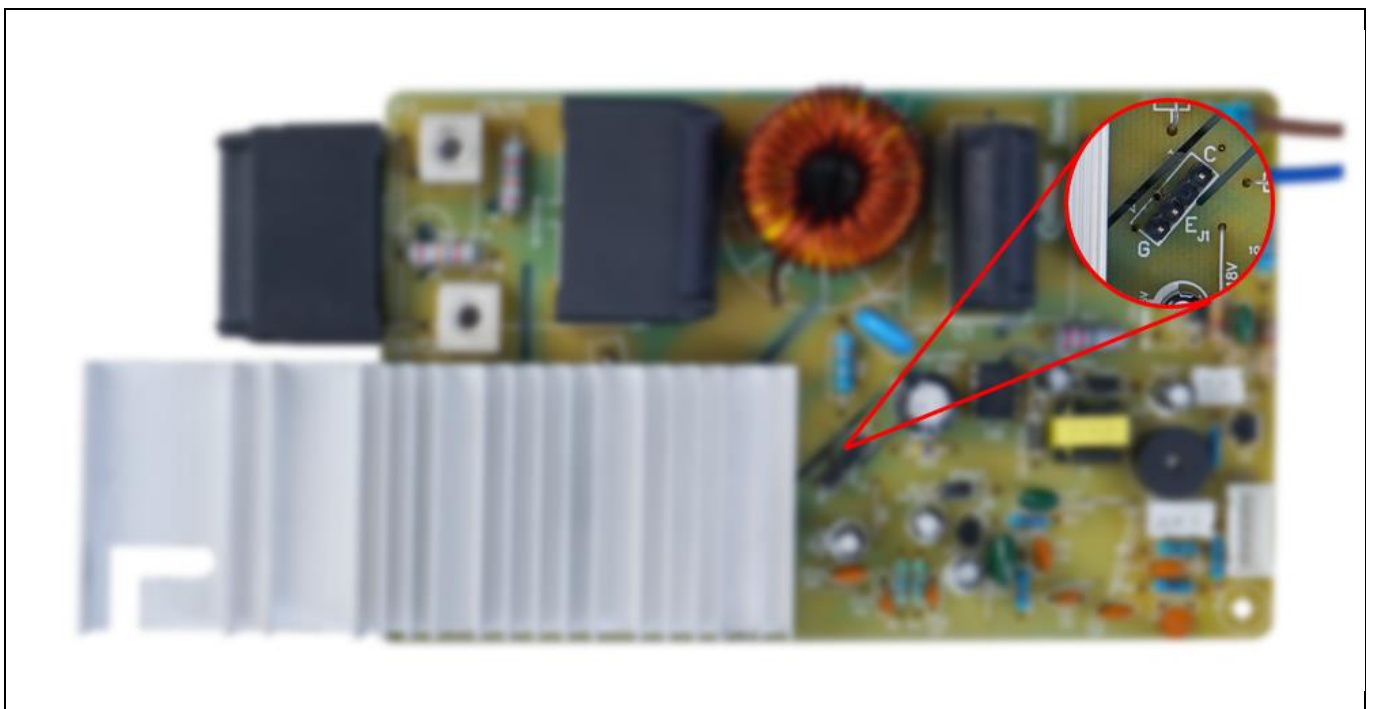

Figure 9 IGBT test points

The current of the power switch can be measured using a Rogowski coil that is hooked around the collector pin of the power switch, as shown in Figure 10.

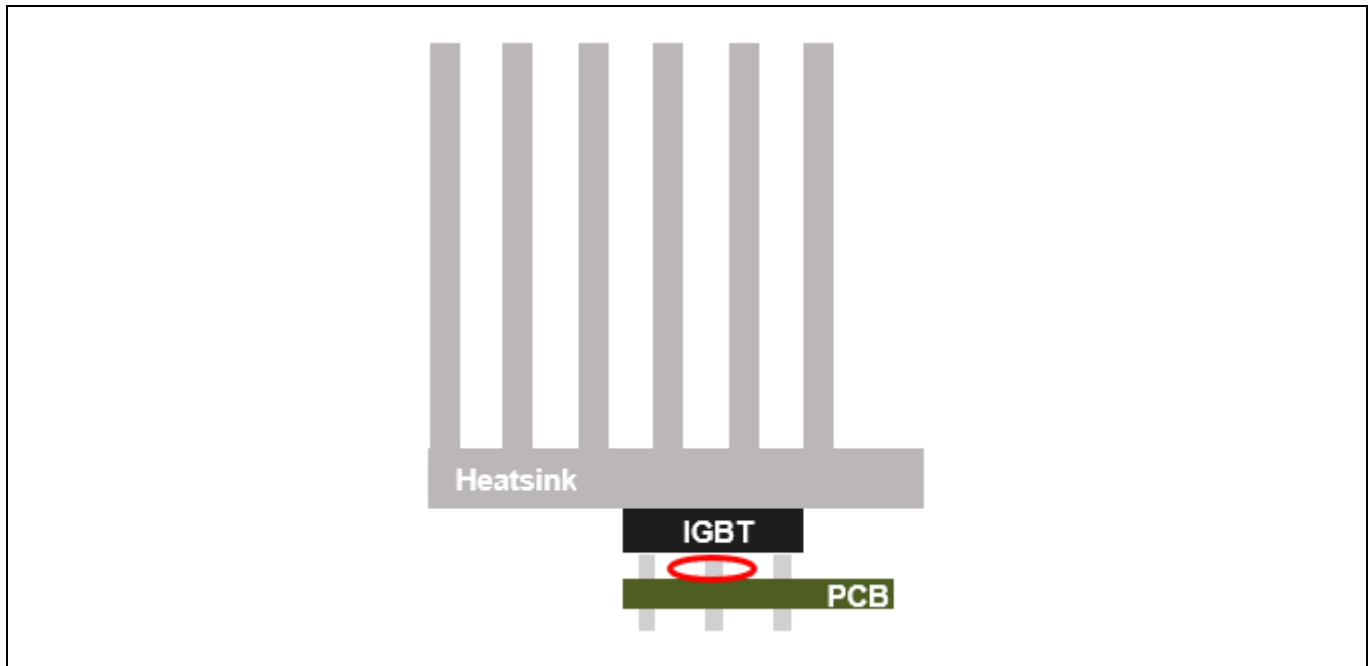

Figure 10 Rogowski coil mounting position

Note: To avoid damage to the measuring equipment all measured signal must have the same reference point, otherwise use a differential probe. Please use an isolated AC supply to properly isolate the board from the grid. If the board is supplied directly from the grid, the oscilloscope must be isolated via an isolation transformer.

Beside the electrical performance, the thermal behavior can also be observed. The thermal data can be used to examine the performance of the power switch or tune the cooling system for the final induction heating system.

Figure 11 shows two recommended ways to mount the thermocouple for measuring the IGBT temperature. The red dots in each image represent the position of the thermocouples. Figure 11 (a) shows a simple way to attach thermocouples, whereas Figure 11 (b) shows a more complex, but more accurate way to measure the temperature of the IGBT. Drilling into the heatsink and mounting the thermocouple flush with the back side of the IGBT is the closest thermal and physical point to measure the temperature of the chip. If the measuring approach shown in Figure 11 (b) is followed, an isolated (battery powered) thermometer must be used.

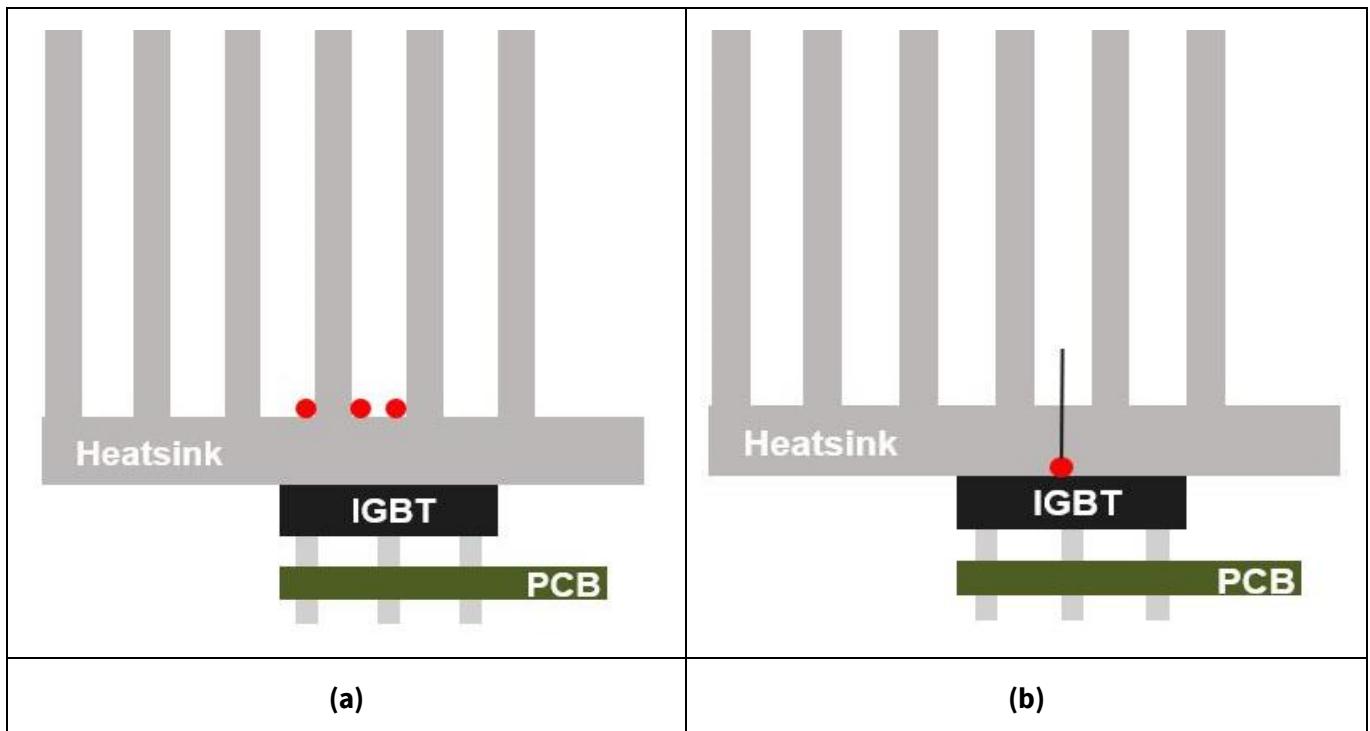

Figure 11 Recommended mounting for the thermocouple

4.2 Test results

In this section the typical operation and characteristic waveforms of the EVAL-IHW25N140R5L induction board are described. In Figures 12 to 15, the waveforms are color-coded as follows:

- Yellow waveform: IGBT current (I_c)
- Cyan / blue waveform: IGBT gate signal (V_{GE})
- Green waveform: IGBT collector-emitter voltage (V_{CE})

At the beginning of every inverter operation a short pulse is applied through the resonant coil to check if there is any cookware on top of it or if the induction cooker is being used without any load. The inverter will remain off in case of a no-load condition. Figure 12 shows the beginning of an operation where a load detection pulse is present.

If a cookware is placed on the resonant coil, the inverter starts operation after a delay of 4 milliseconds. During several initial switching cycles higher currents and hard switching operation can occur till the tank capacitor is charged. During these events, the IGBT will experience high current pulses which can be, by value, over three times the nominal device current. Reverse conducting IGBTs are designed to withstand these conditions. They are defined in Infineon datasheets as “Non-repetitive peak collector current”.

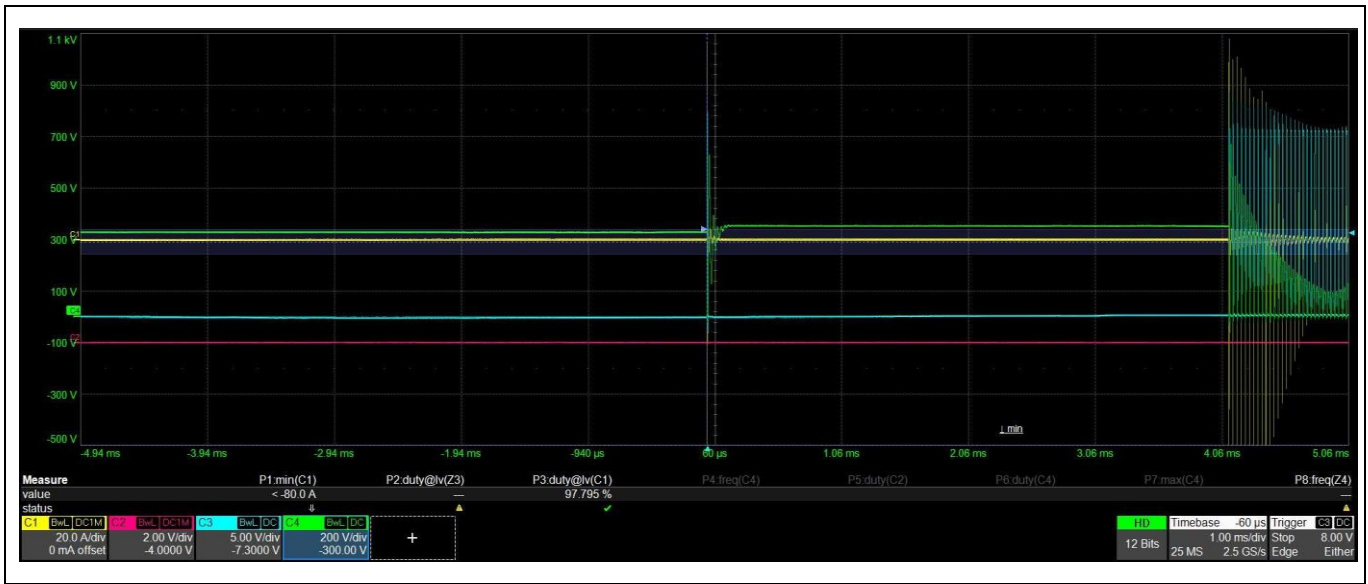

Figure 12 Load detection pulse

A typical operation of this resonant inverter is the so-called soft switching commutation. This technique aims to mitigate switching losses by ensuring that the voltage or current across the power device transitions through zero before the device is turned on or off. This way the losses of the power switch are reduced and a higher efficiency can be achieved. Figure 13 shows a soft switching operation. The yellow waveform shows the current flowing through the IGBT during the “on” state of the power switch. The green waveform represents the resonant voltage across the IGBT.

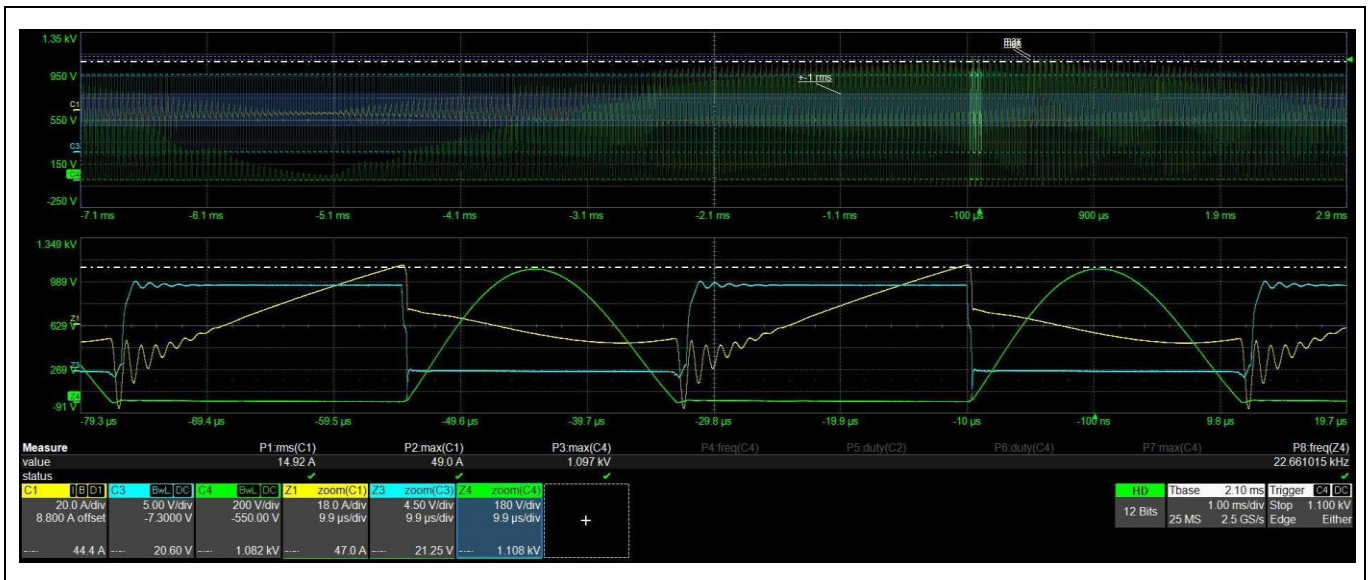

Figure 13 Soft switching operation at maximum power level

System performance

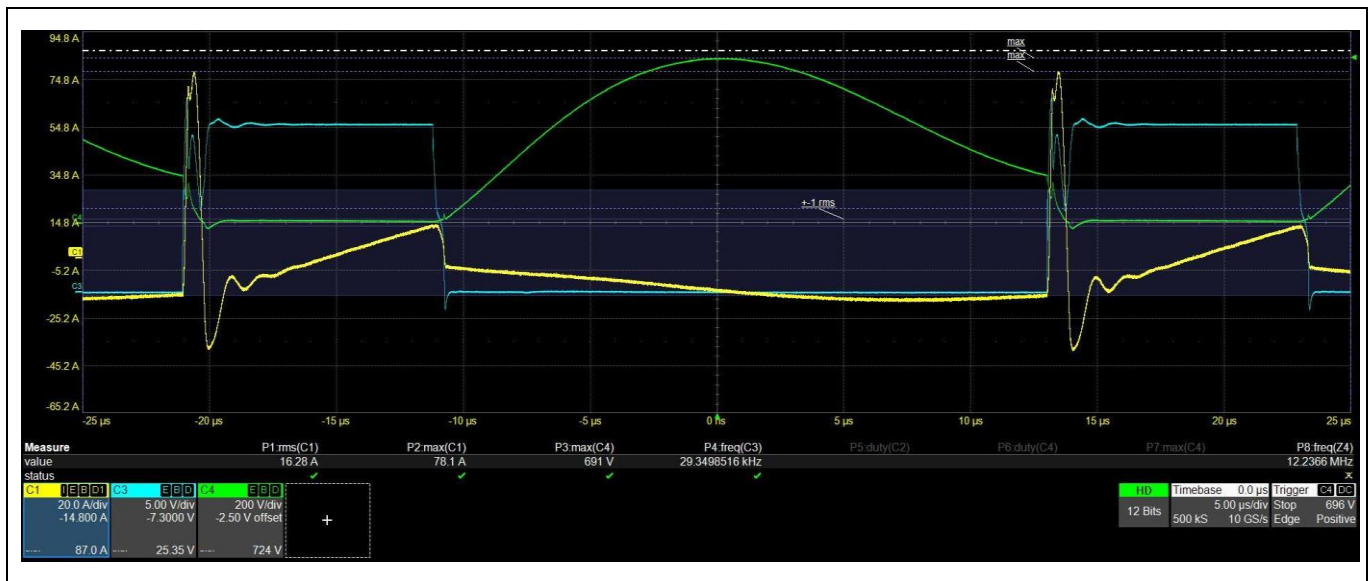

Figure 14 Hard switching operation at power level 3

Induction cookers work across a wide range of output power. When using a typical design approach in soft switching at high power levels if the desired power is reduced the turn-off time of the IGBT may not be sufficient to reach the zero-voltage switching point due to a high equivalent resistance of the load or too little stored energy in the tank. In Figure 14 is shown that the current is zero but the voltage across the device is around 200 V. In such a case, during the turn-on event the IGBT capacitor will be instantaneously discharged causing a flow of high current through the power switch. The power dissipation during the IGBT turn-on can be calculated as the product of the residual energy stored in the resonant capacitance when the IGBT turns on, and the switching frequency of the IGBT:

$$P_{diss, turn-on} = 0.5 * C * V_{ON}^2 * fs$$

To avoid this operation for long periods, the so-called burst mode operation is implemented in the control of the induction inverter. At lower desired output power levels, the inverter operates with higher power but in an ON/OFF manner. For example, if the output power level is set to 400 W, the inverter will run in the 800 W mode for a certain time duration with a duty cycle of 50%. Nevertheless, at the beginning of the inverter operation, several switching cycles occur as hard switching events. The rest of the operation is soft switching to reduce switching losses of the power device.

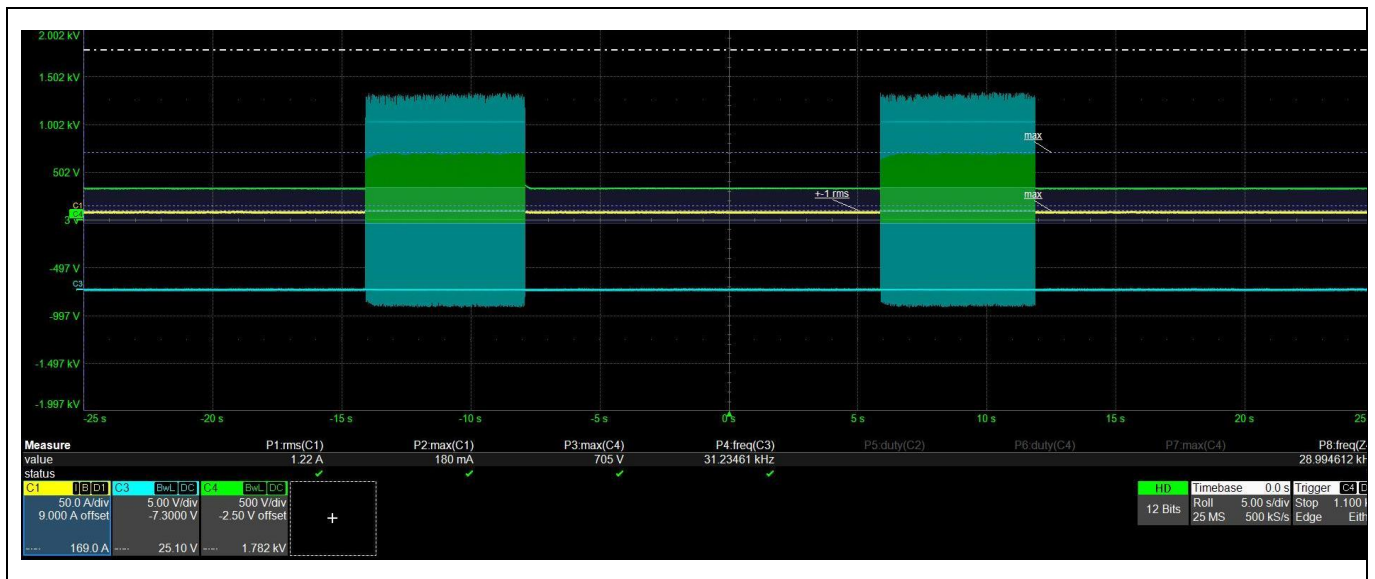

Figure 15 Burst mode operation at power level 3

The result of thermal tests is shown in Table 5. The temperature of the IGBT gets lower with increasing output power. At lower power levels, the hard-switching events lead to increasing losses.

Table 5 IGBT temperatures at different power levels

Power level	Power	IGBT temperature
3	800 W	80.8°C
5	1200 W	61.9°C
7	1600 W	58.4°C
9	2000 W	66.4°C

Appendices

Resonant load details

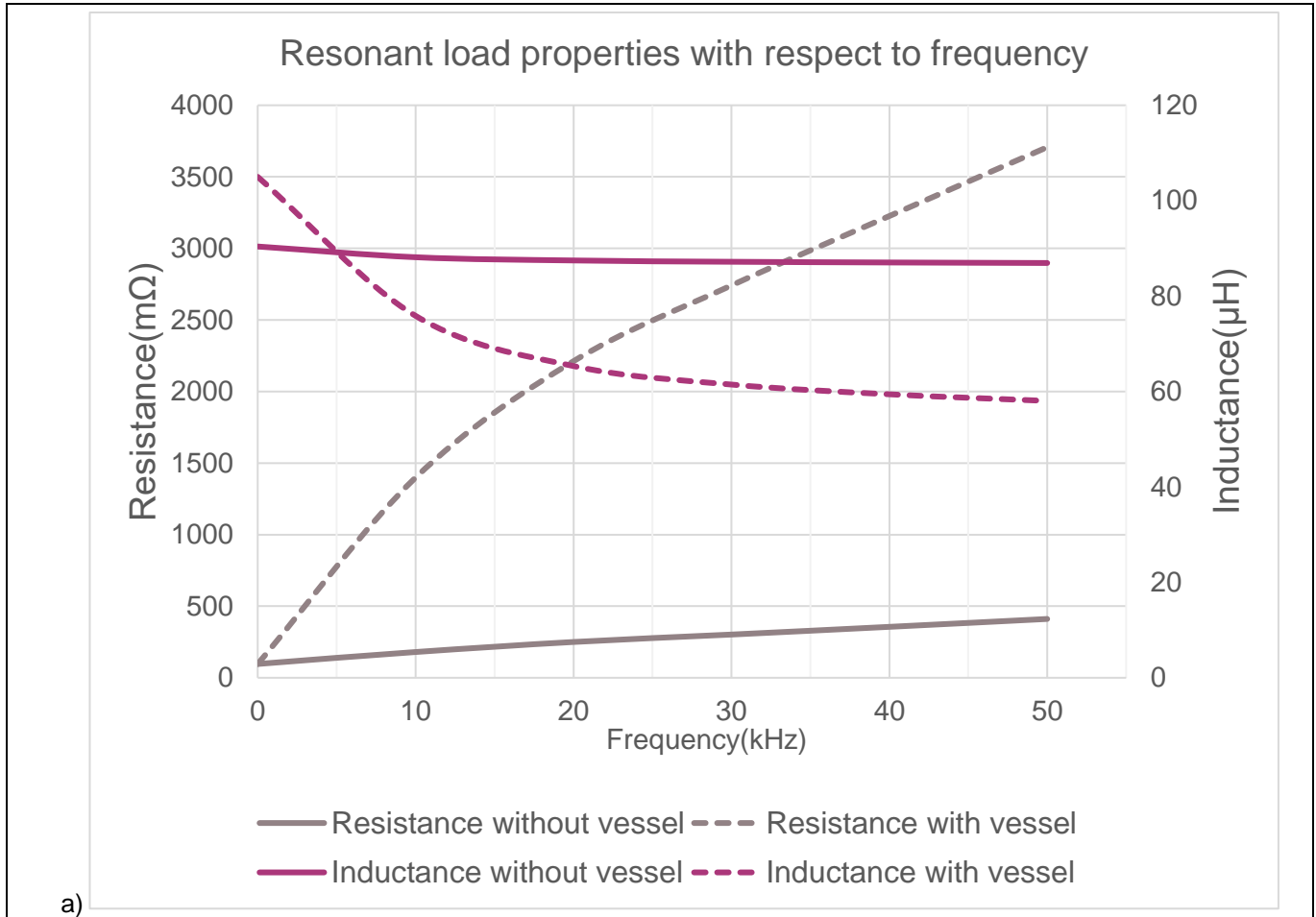

Figure 16 Resonant load parameters across the frequency range

Figure 16 shows electrical properties of the load that comes with the kit. The parameters are shown with and without a vessel so it can be used for user specific conditions. Ensure that individual properties are measured if another coil or cookpot is used together with this evaluation board. Cookware should be placed at a distance of 5 to 10 mm above the coil to avoid excessive losses due to increasing hard switching events. This can be done by placing thermally conductive pads on the coil. Please read Section 4.2 to understand the difference between hard switching and soft switching operations. Using a Mica sheet between the coil and the cookpot is recommended for safety reasons.

References

- [1] The 650 V Reverse Conducting R6 family for induction heating and resonant applications
- [2] EiceDRIVER™ webpage: <https://www.infineon.com/cms/en/product/power/gate-drivers/1ed44171n01b/>

Revision history

Document revision	Date	Description of changes
1.0	04 August 2023	First version

Trademarks

All referenced product or service names and trademarks are the property of their respective owners.

Edition 2023-08-04

Published by

Infineon Technologies AG

81726 Munich, Germany

© 2023 Infineon Technologies AG.

All Rights Reserved.

Do you have a question about this document?

Email: erratum@infineon.com

Document reference

UG-2023-15

Warnings

Due to technical requirements products may contain dangerous substances. For information on the types in question please contact your nearest Infineon Technologies office.

Except as otherwise explicitly approved by Infineon Technologies in a written document signed by authorized representatives of Infineon Technologies, Infineon Technologies' products may not be used in any applications where a failure of the product or any consequences of the use thereof can reasonably be expected to result in personal injury.

X-ON Electronics

Largest Supplier of Electrical and Electronic Components

Click to view similar products for [Power Management IC Development Tools](#) category:

Click to view products by [Infineon](#) manufacturer:

Other Similar products are found below :

[EVB-EP5348UI](#) [BQ25010EVM](#) [ISL80019AEVAL1Z](#) [ISLUSBI2CKIT1Z](#) [ISL8002AEVAL1Z](#) [ISL91108IIA-EVZ](#) [MAX8556EVKIT](#)
[MAX15005AEVKIT+](#) [ISL28022EVKIT1Z](#) [STEVAL-ISA008V1](#) [DRI0043](#) [KITPF8100FRDMEVM](#) [EVB-EN6337QA](#)
[SAMPLEBOXILD8150TOBO1](#) [MAX18066EVKIT#](#) [AP62300WU-EVM](#) [KITA2GTC387MOTORCTRTOBO1](#) [AEK-MOT-TK200G1](#)
[EVLONE65W](#) [STEVAL-ILH006V1](#) [STEVAL-IPE008V2](#) [STEVAL-IPP001V2](#) [STEVAL-ISA013V1](#) [STEVAL-ISA067V1](#) [STEVAL-](#)
[ISQ002V1](#) [TPS2306EVM-001](#) [TPS2330EVM-185](#) [TPS40001EVM-001](#) [SECO-HVDCDC1362-15W-GEVB](#) [BTS7030-2EPA](#)
[LT8638SJV#WPBF](#) [LTC3308AIV#WTRPBF](#) [TLT807B0EPV](#) [BTS71033-6ESA](#) [EV13N91A](#) [EASYPIC V8 OVER USB-C](#) [EV55W64A](#)
[CLICKER 4 FOR STM32F4](#) [EASYMX PRO V7A FOR STM32](#) [CLICKER 4 FOR PIC18F](#) [Si8285_86v2-KIT](#) [PAC52700EVK1](#) [NCP-](#)
[NCV51752D2PAK3LGEVB](#) [ISL81807EVAL1Z](#) [AP33772S-EVB](#) [EVALM7HVIGBTFCINV4TOBO1](#) [903-0300-000](#) [902-0173-000](#) [903-](#)
[0301-000](#) [ROA1286023/1](#)