

EVAL-M1-6ED2230-B1

EiceDRIVER™ Gate Driver IC Evaluation Board Application Note

About this document

Scope and purpose

This application note provides an overview of the evaluation board EVAL-M1-6ED2230-B1 including its main features, key data, pin assignments and mechanical dimensions.

EVAL-M1-6ED2230-B1 is a complete power evaluation board including an EasyPIM™ 1200V Easy1B three-phase module for motor-drive application. In combination with EVAL-M1-6ED2230-B1, it features and demonstrates Infineon's EiceDRIVER™ gate-driver IC technology for motor drives.

The evaluation board EVAL-M1-6ED2230-B1 was developed to support customers during their first steps in designing applications with the 6ED2230S12T EiceDRIVER™ 1200V three-phase gate driver IC.

Intended audience

This application note is intended for all technical specialists working with the EVAL-M1-6ED2230-B1 board.

Ordering Information

Base Part Number	Package	Standard Pack		Orderable Part Number
		Form	Quantity	
EVAL-M1-6ED2230-B1	EVAL	Boxed	1	EVALM16ED2230B1TOBO1
6ED2230S12T	DSO-24	Tape and Reel	1,000	6ED2230S12TXUMA1
EVAL-M1-099M-C or EVAL-M1-1320	MAD-K EVAL	Blister Tray	1	EVALM1099MCTOBO1 or EVALM11302TOBO1
FP15R12W1T4	EasyPIM™ 1B Module	Tray	24	FP15R12W1T4BOMA1



Table of Contents

About this document..... 1

Table of Contents 2

1 Safety precautions..... 3

2 Introduction..... 5

3 Main features 7

3.1 Key data 8

4 Pin assignments11

5 Schematics and layout13

5.1 Schematic overview 13

5.2 Inverter section using FP15R12W1T4 14

5.3 Power supply for gate driver IC..... 15

5.4 Overcurrent protection circuitry..... 15

5.5 Dead-time consideration 16

5.6 PCB layout 16

6 Bill of materials of EVAL-M1-6ED2230-B120

7 Reference22







Revision History23

Safety precautions



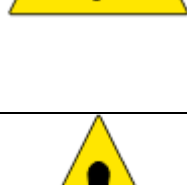

1 Safety precautions

In addition to the precautions listed throughout this manual, please read and understand the following statements regarding hazards associated with development systems.

Table 1 Precautions

	<p>Attention: The ground potential of the EVAL-M1-6ED2230-B1 system is biased to a negative DC bus voltage potential. When measuring voltage waveform by oscilloscope, protection needs to be established. The use of differential probes are recommended. Failure to do so may result in personal injury or death. Darkened display LEDs are not an indication that capacitors have discharged to safe voltage levels.</p>
	<p>Attention: The EVAL-M1-6ED2230-B1 system contains DC bus capacitors which take time to discharge after removal of the main supply. Before working on the drive system, wait three minutes for capacitors to discharge to safe voltage levels. Failure to do so may result in personal injury or death. Darkened display LEDs are not an indication that capacitors have discharged to safe voltage levels.</p>
	<p>Attention: Only personnel familiar with the drive and associated machinery should plan or implement the installation, start-up and subsequent maintenance of the system. Failure to comply may result in personal injury and/or equipment damage.</p>
	<p>Attention: The surfaces of the drive may become hot, which may cause injury.</p>
	<p>Attention: The EVAL-M1-6ED2230-B1 system contains parts and assemblies sensitive to electrostatic discharge (ESD). Electrostatic control precautions are required when installing, testing, servicing or repairing this assembly. Component damage may result if ESD control procedures are not followed. If you are not familiar with electrostatic control procedures, refer to applicable ESD protection handbooks and guidelines.</p>
	<p>Attention: A drive, incorrectly applied or installed, can result in component damage or reduction in product lifetime. Wiring or application errors such as undersizing the motor, supplying an incorrect or inadequate AC supply, or excessive ambient temperatures may result in system malfunction.</p>

Safety precautions

	<p>Attention: Remove and lock out power from the drive before you disconnect or reconnect wires, or perform service work. Wait three minutes after removing power to discharge the bus capacitors. Do not attempt to service the drive until the bus capacitors have discharged to zero. Failure to do so may result in personal injury or death.</p>
	<p>Attention: The EVAL-M1-6ED2230-B1 system is shipped with packing materials that need to be removed prior to installation. Failure to remove all packing materials, which are unnecessary for system installation, may result in overheating or abnormal operating condition.</p>
	<p>Attention: The board is designed to be used with laboratory power supply. The AC input shall not be connected directly to the line grid. Isolating transformer with lineside EMI filter and fuses or laboratory AC power supply unit is required. The use directly at AC line might cause significant malfunctions of other devices in the AC grid, grid breakdown or even fire.</p>
	<p>Attention: Only functional isolation is provided on this board. Additional safety isolation between signal input source and this evaluation board need to be provided by external circuits.</p>
	<p>Attention: Isolated (basic) power supply is recommended for gate driver IC.</p>

2 Introduction

The EVAL-M1-6ED2230-B1 evaluation board is a power board which is compatible with the iMOTION™ MADK (Modular Application Design Kit) for motor control.

The MADK platform is intended for use with various power stages and different control boards, such as Eval-M1-099M-C or Eval-M1-1302. These boards can easily be interfaced via the 20-pin M1 interface connector to the power boards.

The EVAL-M1-6ED2230-B1 evaluation board is designed to give comprehensible power-stage solutions featuring EiceDRIVER™ gate driver IC and EasyPIM™ 1B power module. It provides AC and DC inputs and a 3-phase power output. It contains a single emitter shunt for current sensing and a voltage divider for DC-link voltage measurement.

This evaluation board is available from Infineon. The features of this board are described in the design feature chapter of this document, whereas the remaining paragraphs provide information to enable the customers to copy, modify and qualify the design for production according to their own specific requirements.

Environmental conditions were considered in the design of the EVAL-M1-6ED2230-B1. The design was tested as described in this document, but not qualified with regard to safety requirements, manufacturing and operation over the entire operating temperature range or lifetime. The boards provided by Infineon are subject to functional testing only.

Evaluation boards are not subject to the same procedures as regular products with regard to Returned Material Analysis (RMA), Process Change Notification (PCN) and Product Discontinuation (PD). Evaluation boards are intended to be used under laboratory conditions by specialists only.

Introduction

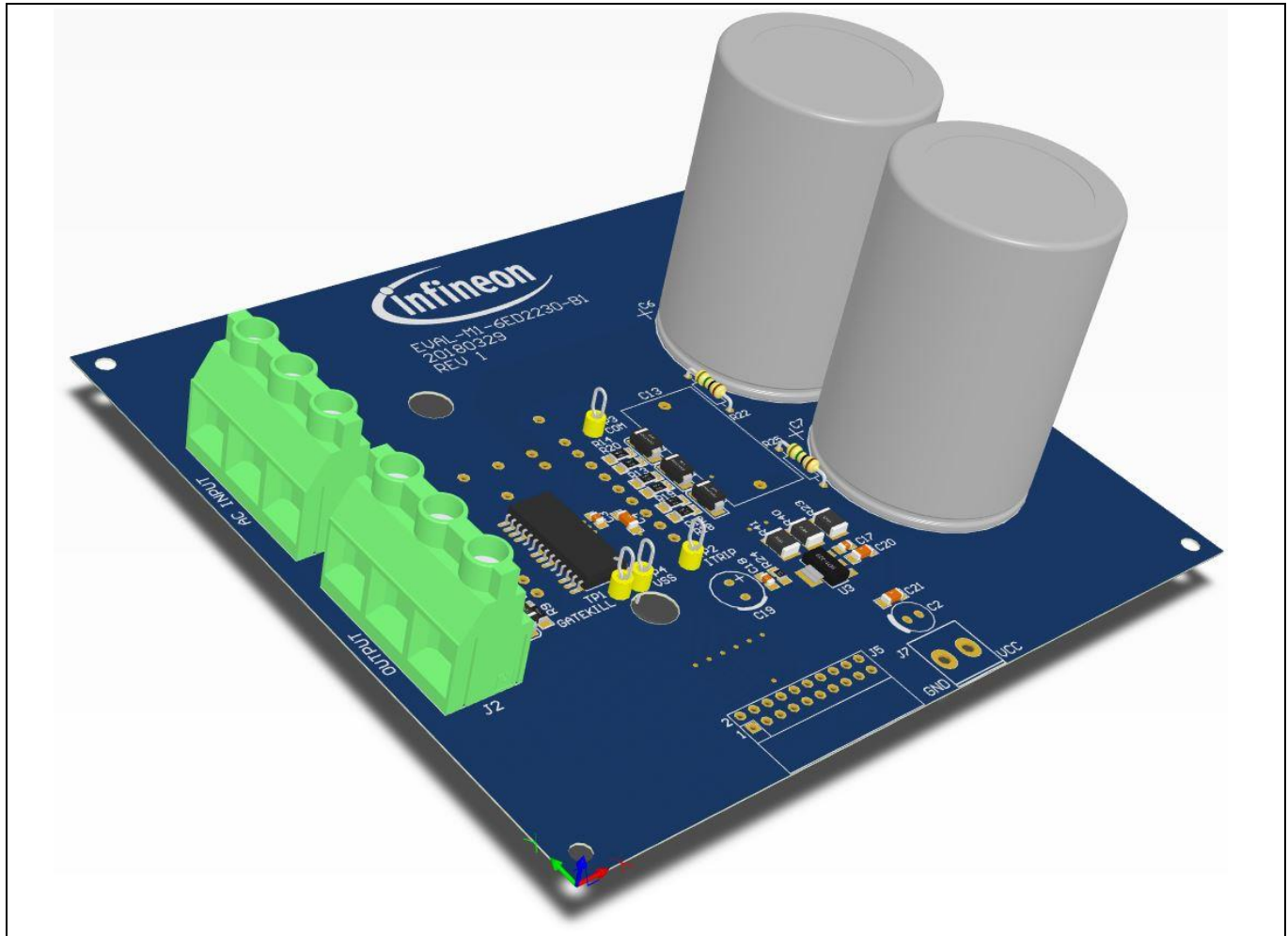

Figure 1 Evaluation board EVAL-M1-6ED2230-B1

Figure 1 shows the picture of the EVAL-M1-6ED2230-B1 evaluation board. This board is compatible with EasyPIM™ modules (mounted on the back side of the evaluation board). This document explains the features and details of this board in combination with an EiceDRIVER™ 6ED2230S12T 3-phase gate driver IC. Ratings and other details of the board are explained in the subsequent sections.

Main features

3 Main features

EVAL-M1-6ED2230-B1 is a complete power evaluation board including a 3-phase 1200 V gate driver IC 6ED2230S12T and an EasyPIM™ module FP15R12W1T4 for motor-drive application. The kit demonstrates Infineon's SOI-based gate driver IC technology for motor drives.

The main features of EiceDRIVER™ 3-phase gate driver IC 6ED2230S12T include:

- Thin Film SOI technology
- Floating channel designed for bootstrap operation
- Fully operational to +1200 V
- Tolerant to negative transient voltage, dV/dt immune
- Gate drive supply range from 12 V to 20 V
- Undervoltage lockout for both channels
- 3.3 V, 5 V, and 15 V input logic-compatible
- Matched propagation delay for all channels
- Outputs in phase with inputs
- Ultra-fast integrated bootstrap diodes
- Overcurrent protection and fault reporting
- Advanced input filter
- Integrated dead-time protection
- Shoot-through (cross-conduction) protection
- Adjustable fault clear timing

The evaluation board characteristics include:

- Up to 2kw motor power range
- On-board overcurrent protection
- EasyPIM™ power module:
FP15R12W1T4 15 A ($T_C = 100^\circ\text{C}$)
- RoHS compliant
- PCB is 130 x 120 mm and has two layers with 35 μm copper each

Main features

3.1 Key data

Figure 2 provides the overview of the 6ED2230S12T’s typical connections for application. For further information regarding these EiceDRIVER™ like static and dynamic electrical behavior, as well as thermal and mechanical characteristics, please refer to the 6ED2230S12T datasheet.

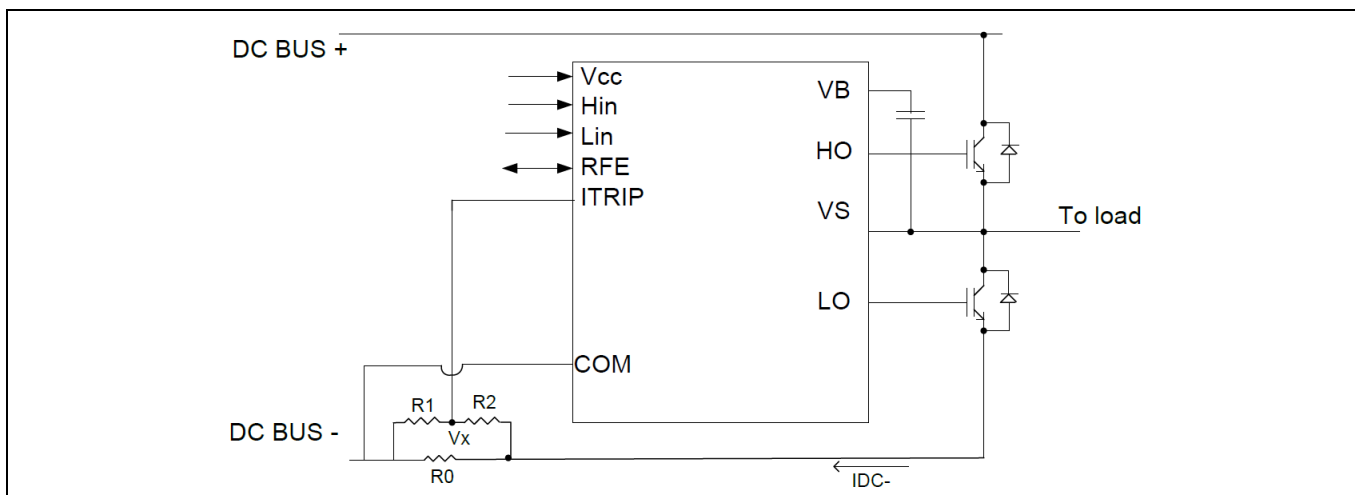

Figure 2 Typical connection of the 6ED2230S12T gate driver IC

Figure 3 Table 2 provides the absolute maximum ratings of the 6ED2230S12T gate driver IC.

Table 2 Absolute maximum ratings of the 6ED2230S12T gate driver IC

Symbol	Description	Min	Max	Unit
V _{CC}	Low-side supply voltage	-0.3	25	V
V _{IN}	Logic input voltage (LIN, HIN, RFE, ITRIP)	V _{SS} - 0.3	V _{CC} + 0.3	V
V _{B1,2,3}	High-side floating supply voltage	-0.3	1225	V
V _{S1,2,3}	High-side floating supply return voltage	V _{B1,2,3} - 25	V _{B1,2,3} + 0.3	V
V _{HO1,2,3}	Floating gate drive output voltage	V _{S1,2,3} - 0.3	V _{B1,2,3} + 0.3	V
V _{LO1,2,3}	Low-side output voltage	-0.3	V _{CC} + 0.3	V
V _{SS}	Logic ground	V _{CC} - 25	V _{CC} + 0.3	V
dV _S /dt	Allowable V _S offset supply transient relative to COM	--	50	V/ns
T _J	Operating junction temperature	--	150	°C
T _S	Storage temperature range	-40	150	°C

Main features

Table 3 **Table 4 depicts the recommended operating conditions of the 6ED2230S12T gate driver IC.**

Table 4 **Recommended operating conditions of 6ED2230S12T gate driver IC**

<i>Symbol</i>	<i>Description</i>	<i>Min</i>	<i>Typ</i>	<i>Max</i>	<i>Unit</i>
$V_{B1,2,3}$	High-side floating supply voltage	$V_S + 12$	$V_S + 15$	$V_S + 20$	V
$V_{S1,2,3}$	High-side floating supply offset voltage	COM - 8	--	1200	V
V_{CC}	Low-side and logic-fixed supply voltage	10	15	20	V
V_{LIN}	Logic input voltage LIN, HIN	V_{SS}	--	$V_{SS} + 5$	V
H_{IN}	High-side PWM pulse width	1	--	--	μs
Dead time	Suggested dead time between LIN and HIN	0.3	0.5	--	μs

Table 5 shows the important specifications of the EVAL-M1-6ED2230-B1 evaluation board.

Table 5 **EVAL-M1-6ED2230-B1 board specifications**

<i>Parameters</i>	<i>Values</i>	<i>Conditions / comments</i>
Output power		
Maximum power	2 kW	Limited by heatsink
Maximum output current (RMS)	2 A	
Power device		
FP15R12W1T4	Easy PIM module	
DC bus voltage		
Maximum DC bus voltage	800 V	
Minimum DC bus voltage	200 V	
VCC supply voltage		
Gate driver IC supply voltage	15 V	
Protections		
Overcurrent protection trigger level	6 Apk	Configure by changing shunt resistors
On-board power supply		
3.3V	3.3 V+/-2%, Max 800 mA	
PCB characteristics		
Material	FR4, 1.6 MM thickness Copper thickness = 1oz (35 μm)	
Dimensions	130 mm x 120 mm	
System environment		
Ambient temperature	0-70°C	95%RH Max (non-condensing)

Main features

Figure 4 and Figure 5 point out the functional groups of the EVAL-M1-6ED2230-B1 evaluation board.

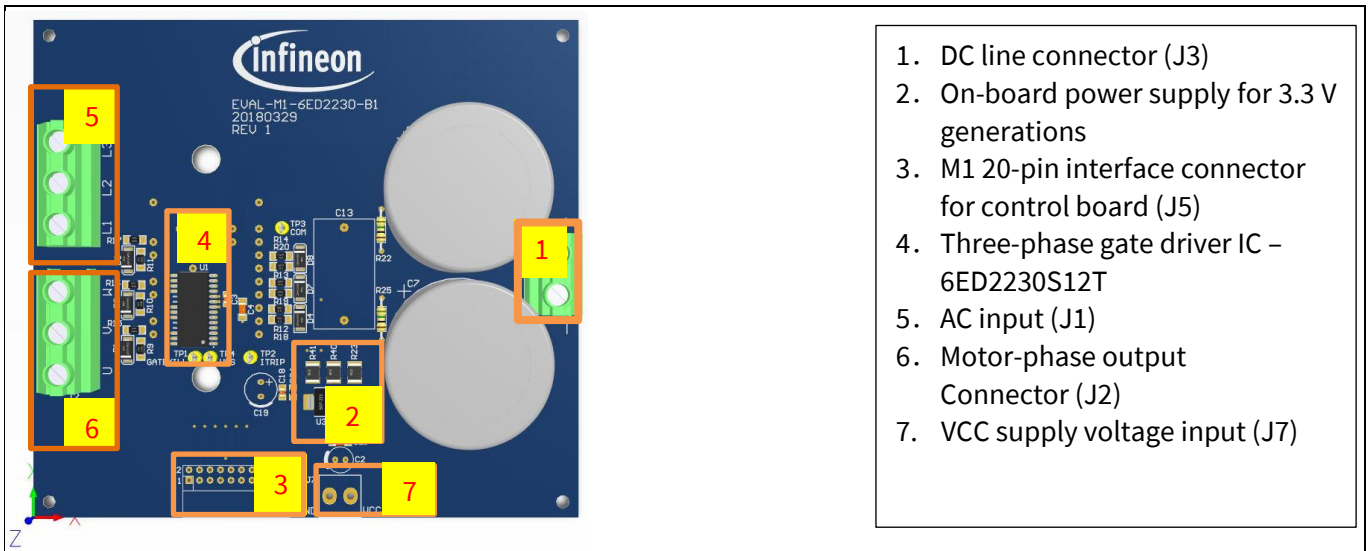

Figure 4 Functional groups of the EVAL-M1-6ED2230-B1 evaluation board's top side

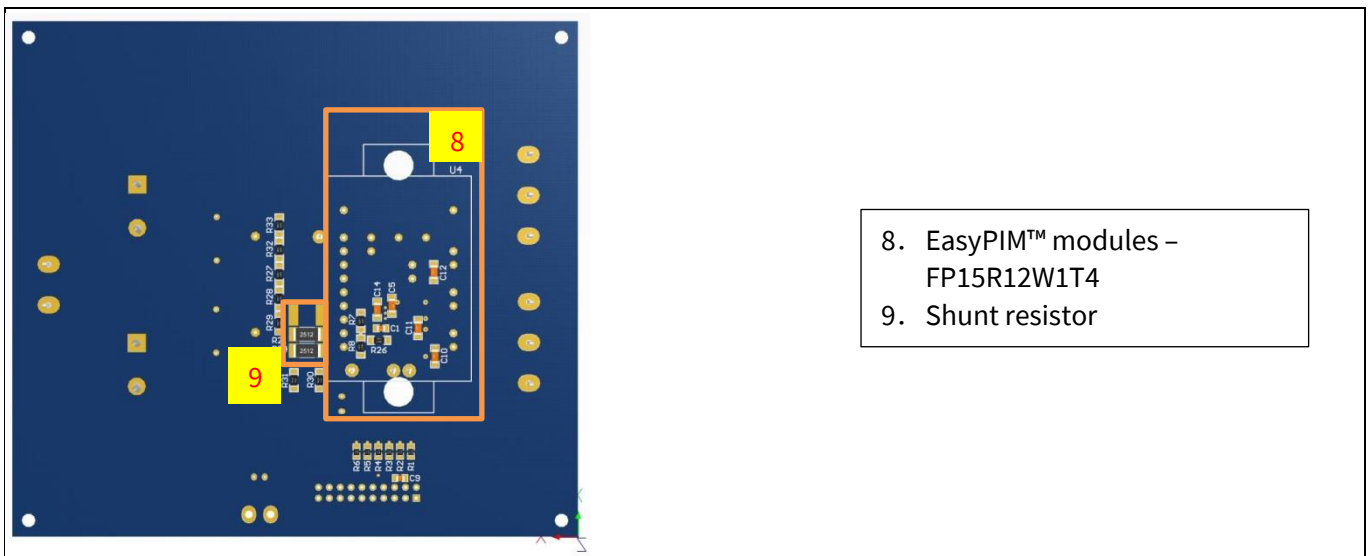

Figure 5 Functional groups of the EVAL-M1-6ED2230-B1 evaluation board's bottom side (heatsink is removed)

Pin assignments

4 Pin assignments

General information about the connectors of the EVAL-M1-6ED2230-B1 evaluation board is reported.

Table 6 includes the details of the DC input connector J3.

Table 7 includes the detail of the AC input connector J1.

Table 8 denotes the details of the motor-side connector J2.

Table 9 denotes the details of the gate driver VCC supply connector J7.

Table 6 J3- DC input connector

S. No.	Pin	Details
1	BUS	DC + connector
2	VSS	DC - connector

Table 7 J1- AC input connector

S. No.	Pin	Details
1	L1	Connected to AC input L1
2	L2	Connected to AC input L2
3	L3	Connected to AC input L3

Table 8 J2- Motor-side connector

S. No.	Pin	Details
1	U	Connected to motor phase U
2	V	Connected to motor phase V
3	W	Connected to motor phase W

Table 9 J7- Gate driver IC VCC supply connector

S. No.	Pin	Details
1	GND	Gate driver IC ground
2	VCC	Gate driver IC 15V supply

Table 10 provides the pin assignments of the M1 20 pin interface connector J5. This connector is the interface to the power board.

Table 10 J5- iMOTION™ MADK-M1 20-pin interface connector for power board

Pin	Name	Pin name connectors
1	PWMUH	3.3 V compatible logic input for high-side gate driver, phase U
2	VSS	Ground
3	PWMUL	3.3 V compatible logic input for low-side gate driver, phase U
4	VSS	Ground
5	PWMVH	3.3 V compatible logic input for high-side gate driver, phase V
6	+3.3 V	3.3V power supply
7	PWMVL	3.3 V compatible logic input for low-side gate driver, phase V

Pin assignments

<i>Pin</i>	<i>Name</i>	<i>Pin name connectors</i>
8	+3.3 V	3.3V power supply
9	PWMWH	3.3 V compatible logic input for high-side gate driver, phase W
10	SHUNT+	Shunt voltage +
11	PWMWL	3.3 V compatible logic input for low-side gate driver, phase W
12	SHUNT-	Shunt voltage -
13	GATEKILL	Gatekill
14	Vbus sense	Input, DC bus voltage sensing after 4 Mohm resistors

5 Schematics and layout

To meet individual customer requirements and make the EVAL-M1-6ED2230-B1 evaluation board a basis for development or modification, all necessary technical data like schematics, layouts and components are included in this chapter.

5.1 Schematic overview

Figure 6 provides the overview of the schematic of the EVAL-M1-6ED2230-B1 evaluation board.

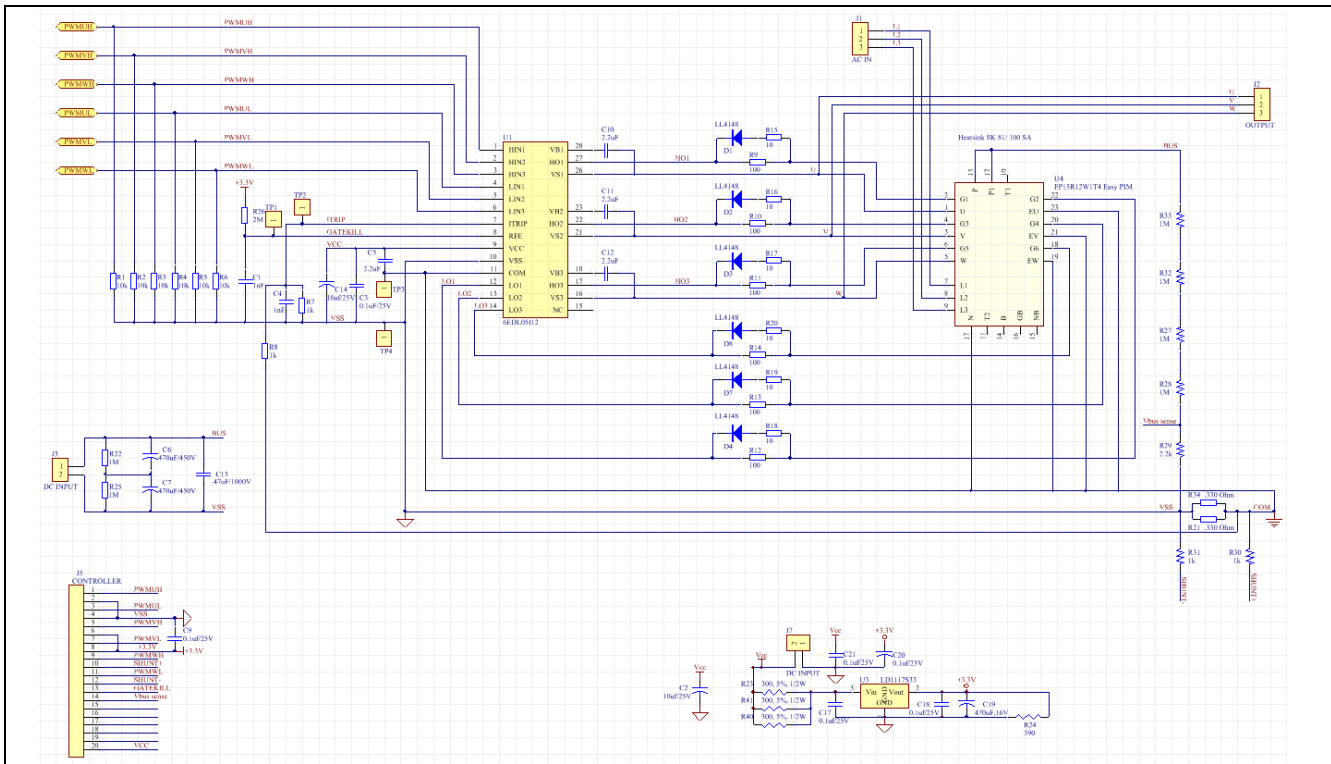

Figure 6 Schematic of the EVAL-M1-6ED2230-B1 evaluation board

The gate resistor values should be adjusted according to the application and load current when this board is used to drive a load.

5.2 Inverter section using FP15R12W1T4

The inverter section is implemented using the EasyPIM™ modules FP15R12W1T4 as sketched in Figure 7. It is a 1200 V 3-phase module which includes rectifier, brake-chopper and IGBT inverter stages.

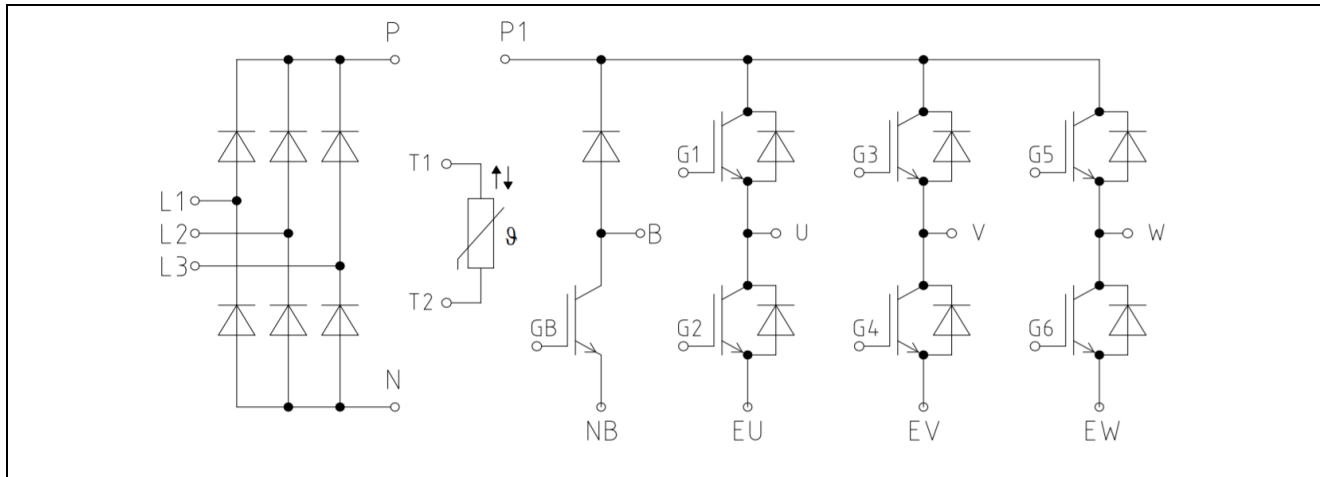

Figure 7 Schematic of the 3-phase inverter section using EasyPIM™ modules FP15R12W1T4 on the EVAL-M1-6ED2230-B1 evaluation board

The input power can either be DC which is fed in between node P and N by connector J3, or be AC which is fed in at node L1, L2 and L3 by connector J1. The NTC thermistor and also chopper are not connected on this evaluation board.

5.3 Power supply for gate driver IC

Figure 8 depicts the schematic of the power supply available on the EVAL-M1-6ED2230-B1 board. The circuit includes a LD1117S33 linear regulator that is used to generate 3.3 V from the 15V VCC. VCC is used to supply the IC 6ED2230S12T gate driver and it need to be supplied externally. The 3.3 V power supply is used in the circuits which are related to Fault/Enable features. Both, VCC and 3.3 V are also present on the 20-pin J5 interface connector to the power circuitry on the controller board.

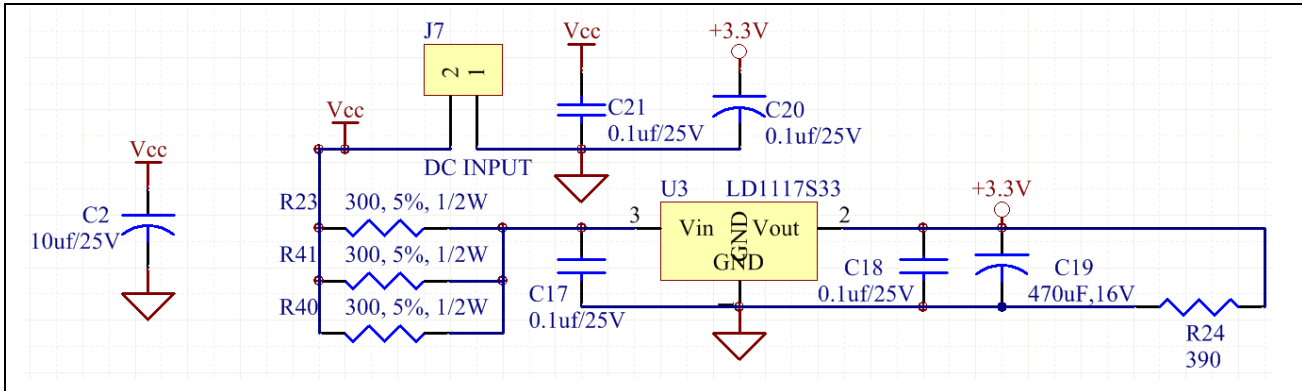

Figure 8 Power supply section of the EVAL-M1-6ED2230-B1 evaluation board

5.4 Overcurrent protection circuitry

Figure 9 displays the over-current protection circuitry. The comparator threshold can be set via the voltage divider. The ITRIP pin senses this voltage. Once an overcurrent event is detected, the driver IC outputs are shut down, and the RFE pin is pulled down to VSS.

On the EVAL-M1-6ED2230B1 evaluation board, the resistance value of the shunt resistors (2 x 0.33 ohm in parallel, which are used to detect the overcurrent event) is chosen to sense 6A peak current through the shunt resistors which will trigger the overcurrent protection and shut down the outputs of gate driver IC. In case a different current level is preferred (e.g. under different load condition), the shunt resistor needs to be adjusted accordingly, taking into consideration voltage drop and power dissipation.

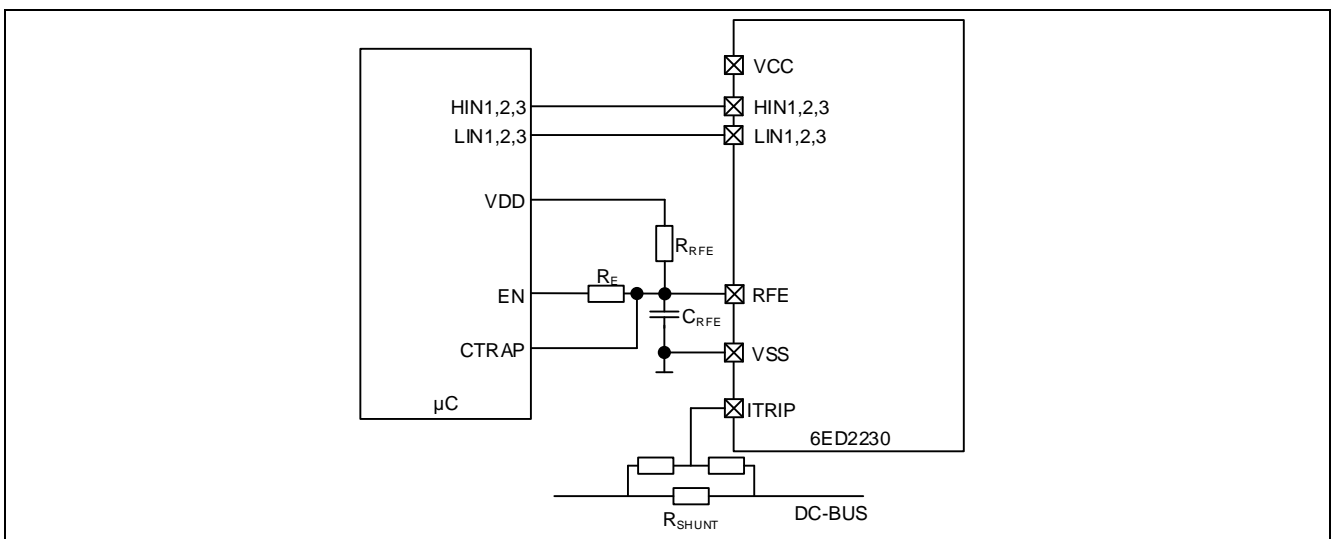

Figure 9 Overcurrent protection circuit on the EVAL-M1-6ED2230-B1 evaluation board

5.5 Dead-time consideration

To guarantee proper system functioning and to prevent shoot-through, a minimum of 1 us dead time is recommended from the controller side.

5.6 PCB layout

The layout of this board can be used for different voltages or power classes of power board. The PCB has two electrical layers with 35 μm copper by default, and its size is 130 × 120 mm. The PCB board thickness is 1.6 mm. Contact our technical support team to get more detailed information and the latest Gerber files.

Figure 10 illustrates the top assembly print of the evaluation board.

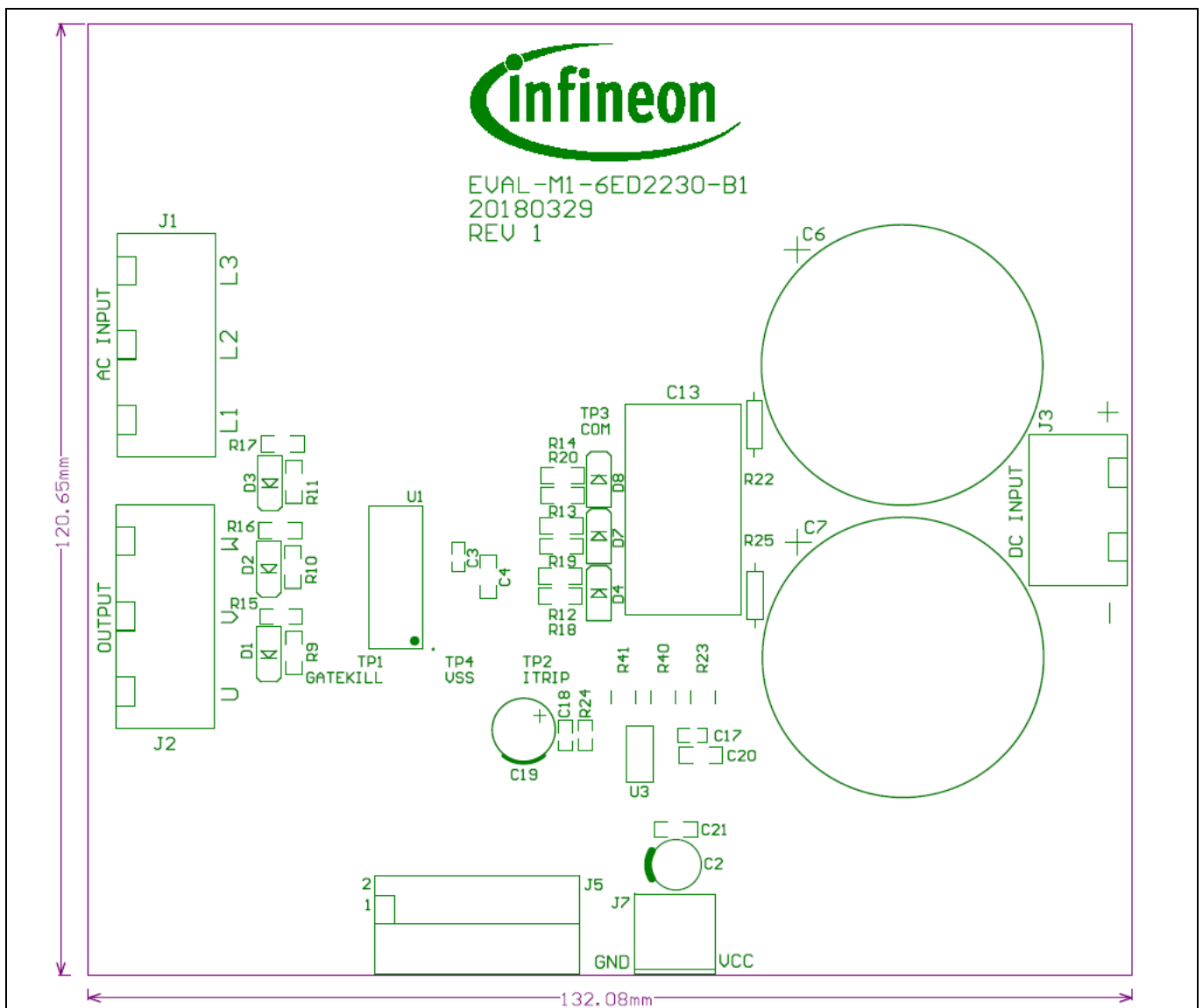

Figure 10 Top assembly print of the EVAL-M1-6ED2230-B1 evaluation board

Figure 11 depicts the bottom assembly print of the evaluation board.

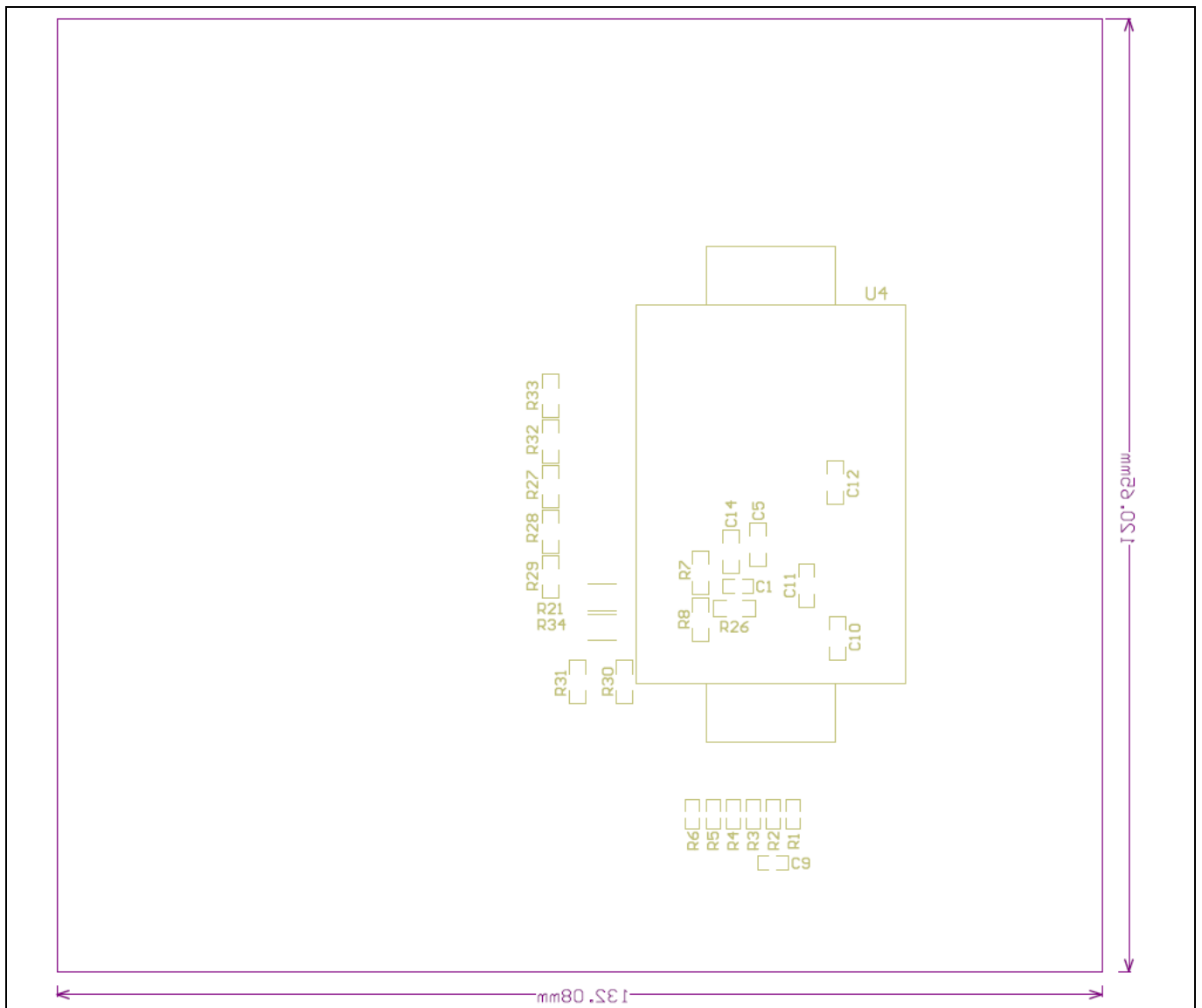

Figure 11 Bottom assembly print of the EVAL-M1-6ED2230-B1 evaluation board

The top layer routing of the PCB is provided in the following Figure 12.

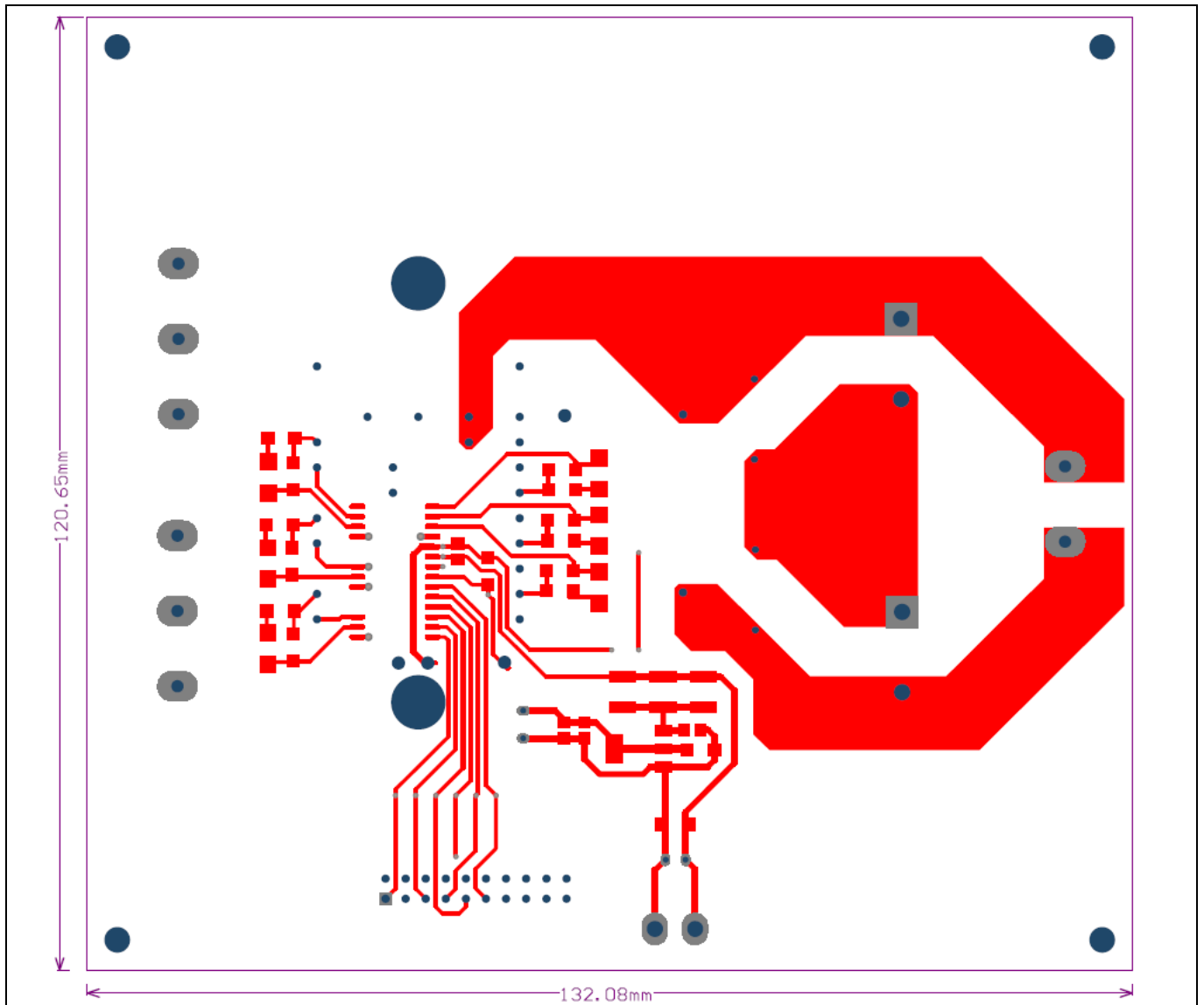

Figure 12 Top layer routing of the EVAL-M1-6ED2230-B1 evaluation board

Figure 13 illustrates the bottom layer routing of the PCB.

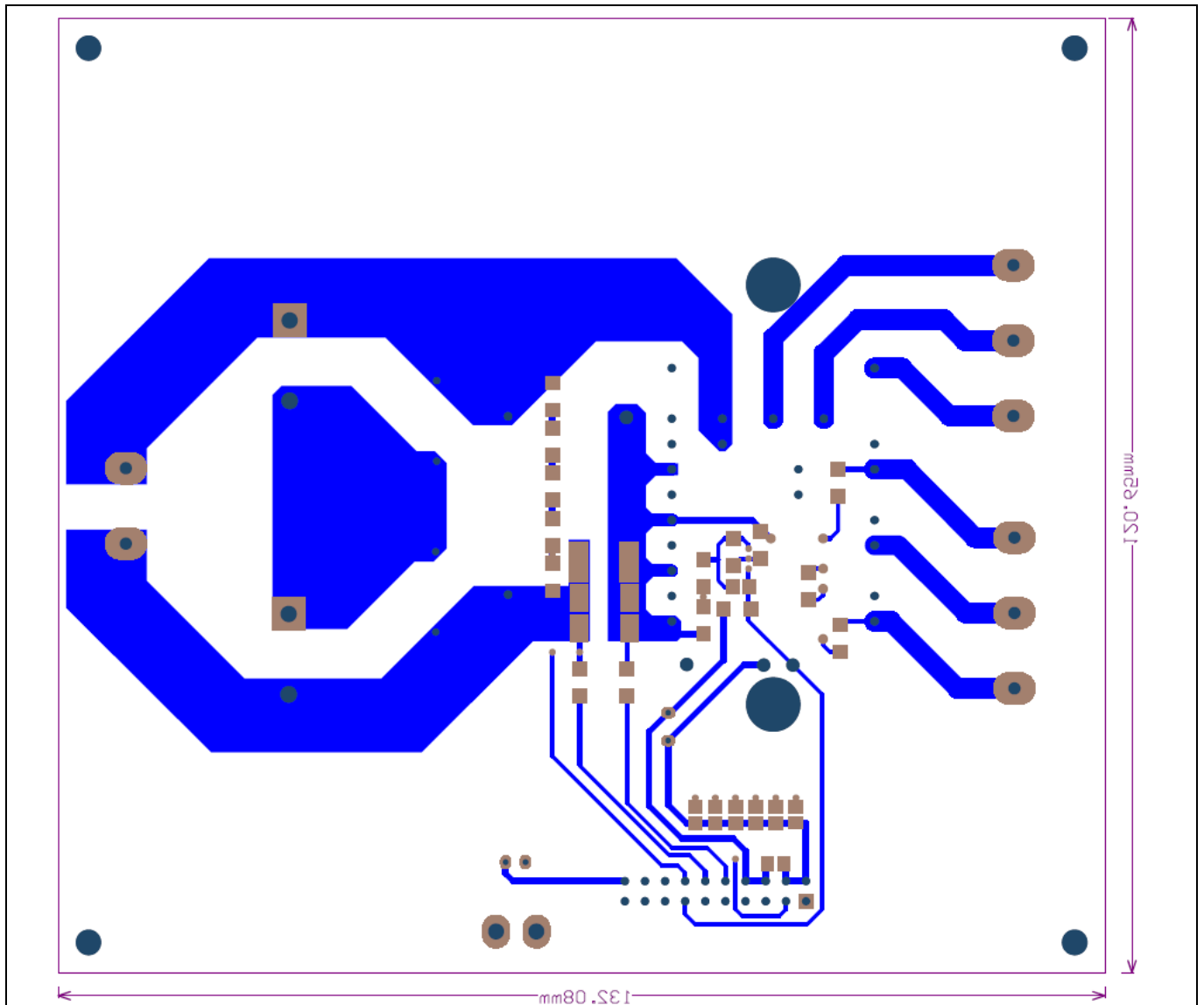

Figure 13 Bottom layer routing of the EVAL-M1-6ED2230-B1 evaluation board

6 Bill of materials of EVAL-M1-6ED2230-B1

Table 11 provides the complete bill of materials for the EVAL-M1-6ED2230-B1 board.

Table 11 Bill of materials

Description	Component	Designator	Footprint	LibRef	Quantity	Infineon Ordering# /Digikey Part#
1 nF	Capacitor	C1	0805 C	CAP_1	1	
10 uf / 25 V	Capacitor	C2	EC063	CAPACITOR	1	P15799CT-ND
0.1 uF / 25 V	Capacitor	C3, C9, C17, C18	0805 C	CAP_1, CAP, CAP NP, CAP NP	4	
1 nF	Capacitor	C4	1206 C	CAP_1	1	399-9300-1-ND
2.2 uF	Capacitor	C5, C10, C11, C12	1206 C	CAP_1	4	478-9949-1-ND
470 uF / 450 V	Capacitor	C6, C7	Cap Pol 10Px35x40	CAPACITOR	2	338-4195-ND
.47 uF / 1000 V	Capacitor	C13	CAP_26.5X14.5MM	CAP_1	1	399-5977-ND
10 uf / 25 V	Capacitor	C14	1206 C	CAPACITOR	1	478-9944-1-ND
470 uF, 16 V	Capacitor	C19	CAP_PAN_M_8x3.5	CAPACITOR	1	P5532-ND
0.1 uf / 25 V	Capacitor	C20, C21	1206 C	CAPACITOR, CAP	2	399-11180-1-ND
LL4148		D1, D2, D3, D4, D7, D8	SMA Diode	DIODE	6	LL4148FSCT-ND
AC IN	Connector	J1	9.52X3TB	CON3	1	277-1272-ND
OUTPUT	Connector	J2	9.52X3TB	CON3	1	277-1272-ND
DC INPUT	Connector 2 Pin	J3	9.52X2TB	CON2	1	277-1271-ND
CONTROLLER	Connector 20 Pin	J5	HDR2-20	20PIN	1	SAM1224-10-ND

EVAL-M1-6ED2230-B1**EiceDRIVER™ Gate Driver IC Evaluation Board Application Note****Bill of materials of EVAL-M1-6ED2230-B1**

VCC INPUT	Connector 2 Pin	J7	5.08X2N	CON2	1	A112698-ND
10 k	Resistor	R1, R2, R3, R4, R5, R6	0805 R	Res2	6	
1 k	Resistor	R7, R8, R30, R31	1206 R	Res2	4	
100	Resistor	R9, R10, R11, R12, R13, R14	1206 R	Res2	6	
10	Resistor	R15, R16, R17, R18, R19, R20	1206 R	Res2	6	
.330 Ohm	Resistor	R21, R34	6432-2512	Res2	2	CSRN2512FKR330 CT-ND
1M	Resistor	R22, R25	RES AXIAL-0.4	Res2	2	1MWCT-ND
300, 5%, ½ W	Resistor	R23, R40, R41	1812	R	3	P300WCT-ND
390	Resistor	R24	0805 R	RES1	1	
2M	Resistor	R26	1206 R	Res2	1	
1M	Resistor	R27, R28, R32, R33	1206 R	RES2	4	
2.2k	Resistor	R29	1206 R	RES2	1	
TEST POINT		TP1, TP2, TP3, TP4	TP Compact	TEST POINT	4	
6ED2230S12T	3-Phase Bridge Driver IC	U1	SOIC127P1030X26 5-28N	6ED2230S12T	1	6ED2230S12TXUM A1
LD1117S33	Voltage Regulator IC	U3	SOT-223	Volt Reg	1	
FP15R12W1T 4 Easy PIM		U4	FP15R12W1T4	FP15R12W1T4 Easy PIM	1	FP15R12W1T4BO MA1

7 Reference

[1] Datasheet of Infineon EiceDRIVER™ 6ED2230S12T is available for download on Infineon's website

[2] Datasheet of Infineon EasyPIM™ FP15R12W1T4 is available for download on Infineon's website

Revision History

Major changes since the last revision

<i>Version number</i>	<i>Revision Date</i>	<i>Revision description</i>
0.1	2018-02-22	First version
0.4	2018-04-09	Board dimension update
1.0	2018-04-30	First release
1.3	2020-04-16	Added Infineon Ordering Information in cover page

Trademarks of Infineon Technologies AG

AURIX™, C166™, CanPAK™, CIPOS™, CoolGaN™, CoolMOS™, CoolSET™, CoolSiC™, CORECONTROL™, CROSSAVE™, DAVE™, DI-POL™, DrBlade™, EasyPIM™, EconoBRIDGE™, EconoDUAL™, EconoPACK™, EconoPIM™, EiceDRIVER™, eupec™, FCOS™, HITFET™, HybridPACK™, Infineon™, ISOFACE™, IsoPACK™, i-Wafer™, MIPAQ™, ModSTACK™, my-d™, NovalithIC™, OmniTune™, OPTIGA™, OptiMOS™, ORIGA™, POWERCODE™, PRIMARION™, PrimePACK™, PrimeSTACK™, PROFET™, PRO-SIL™, RASIC™, REAL3™, ReverSave™, SatRIC™, SIEGET™, SIPMOS™, SmartLEWIS™, SOLID FLASH™, SPOC™, TEMPFET™, thinQ!™, TRENCHSTOP™, TriCore™.

Trademarks updated August 2015

Other Trademarks

All referenced product or service names and trademarks are the property of their respective owners.

Edition <2020-04-16>

Published by

Infineon Technologies AG
81726 Munich, Germany

© 2020 Infineon Technologies AG.
All Rights Reserved.

Do you have a question about this document?

Email: erratum@infineon.com

AN2018-06 EVAL-M1-6ED2230-B1
Document reference

IMPORTANT NOTICE

The information contained in this application note is given as a hint for the implementation of the product only and shall in no event be regarded as a description or warranty of a certain functionality, condition or quality of the product. Before implementation of the product, the recipient of this application note must verify any function and other technical information given herein in the real application. Infineon Technologies hereby disclaims any and all warranties and liabilities of any kind (including without limitation warranties of non-infringement of intellectual property rights of any third party) with respect to any and all information given in this application note.

The data contained in this document is exclusively intended for technically trained staff. It is the responsibility of customer's technical departments to evaluate the suitability of the product for the intended application and the completeness of the product information given in this document with respect to such application.

For further information on the product, technology delivery terms and conditions and prices please contact your nearest Infineon Technologies office (www.infineon.com).

Please note that this product is not qualified according to the AEC Q100 or AEC Q101 documents of the Automotive Electronics Council.

WARNINGS

Due to technical requirements products may contain dangerous substances. For information on the types in question please contact your nearest Infineon Technologies office.

Except as otherwise explicitly approved by Infineon Technologies in a written document signed by authorized representatives of Infineon Technologies, Infineon Technologies' products may not be used in any applications where a failure of the product or any consequences of the use thereof can reasonably be expected to result in personal injury.

X-ON Electronics

Largest Supplier of Electrical and Electronic Components

Click to view similar products for [Power Management IC Development Tools](#) category:

Click to view products by [Infineon](#) manufacturer:

Other Similar products are found below :

[EVB-EP5348UI](#) [MIC23451-AAAYFL EV](#) [MIC5281YMME EV](#) [124352-HMC860LP3E](#) [DA9063-EVAL](#) [ADP122-3.3-EVALZ](#) [ADP130-0.8-EVALZ](#) [ADP130-1.8-EVALZ](#) [ADP1740-1.5-EVALZ](#) [ADP1870-0.3-EVALZ](#) [ADP1874-0.3-EVALZ](#) [ADP199CB-EVALZ](#) [ADP2102-1.25-EVALZ](#) [ADP2102-1.875EVALZ](#) [ADP2102-1.8-EVALZ](#) [ADP2102-2-EVALZ](#) [ADP2102-3-EVALZ](#) [ADP2102-4-EVALZ](#) [AS3606-DB](#) [BQ25010EVM](#) [BQ3055EVM](#) [ISLUSBI2CKIT1Z](#) [LM2734YEVAL](#) [LP38512TS-1.8EV](#) [EVAL-ADM1186-1MBZ](#) [EVAL-ADM1186-2MBZ](#) [ADP122UJZ-REDYKIT](#) [ADP166Z-REDYKIT](#) [ADP170-1.8-EVALZ](#) [ADP171-EVALZ](#) [ADP1853-EVALZ](#) [ADP1873-0.3-EVALZ](#) [ADP198CP-EVALZ](#) [ADP2102-1.0-EVALZ](#) [ADP2102-1-EVALZ](#) [ADP2107-1.8-EVALZ](#) [ADP5020CP-EVALZ](#) [CC-ACC-DBMX-51](#) [ATPL230A-EK](#) [MIC23250-S4YMT EV](#) [MIC26603YJL EV](#) [MIC33050-SYHL EV](#) [TPS60100EVM-131](#) [TPS65010EVM-230](#) [TPS71933-28EVM-213](#) [TPS72728YFFEVM-407](#) [TPS79318YEQEV](#) [UCC28810EVM-002](#) [XILINXPWR-083](#) [LMR22007YMINI-EVM](#)