

EVAL_PMG1_B1_DRP kit

The EVAL_PMG1_B1_DRP is an evaluation kit for EZ-PD™ PMG1-B1 USB Power Delivery (PD) Microcontroller (MCU) with integrated buck-boost battery charger. EZ-PD™ PMG1-B1 is targeted for battery powered applications that sink or source power through USB-C port and needs a MCU to implement product features. Some of the target applications include cordless power tool chargers, wireless speakers, and portable electronics. The kit can be used to sink up to 100 W (20 V @ 5 A) and source up to 27 W (9 V @ 3 A). The kit can also be used to charge 2-5 cell batteries with the ability to customize the battery charging algorithm based on customer needs.

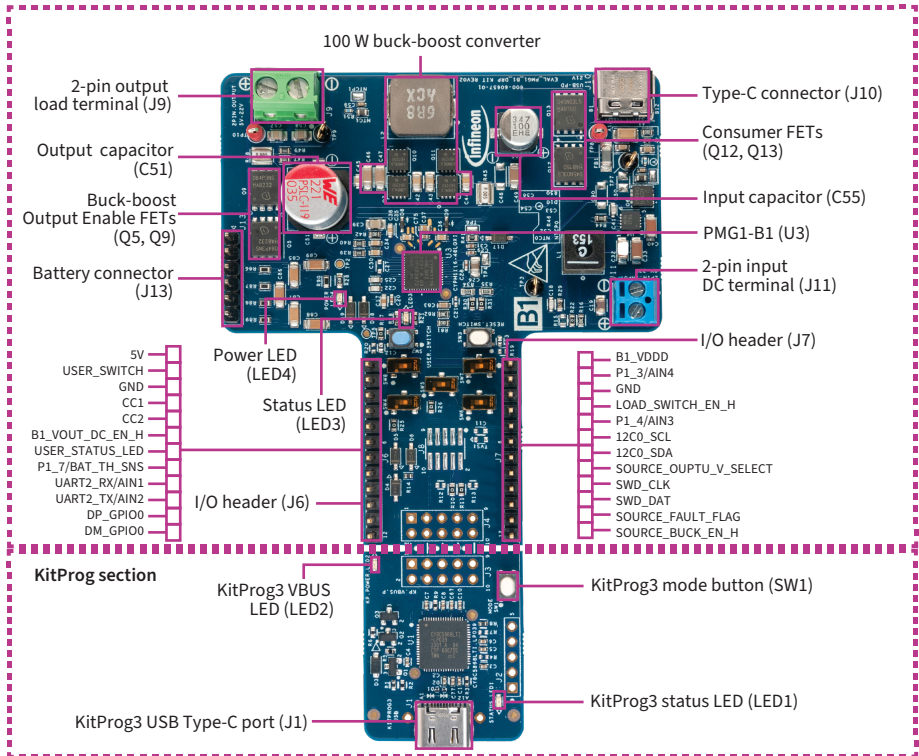

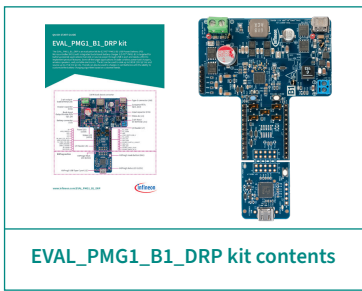

Before you start

- Ensure that you have a USB PD 3.1 capable USB-C power adapter (e.g., Apple 96 W USB-C power adapter) with a compatible USB PD 3.1 capable Type-C cable.
- Ensure that you have a power supply or AC/DC power adapter with 15V, 2A.

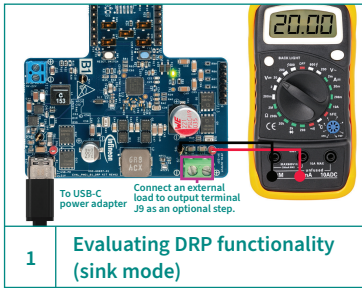

Step 1: Evaluating DRP functionality (sink mode)

- 1 Connect the USB-C PD port (J10) of the EVAL_PMG1_B1_DRP kit to the USB-C power adapter using the USB-C cable.
- 2 To confirm that board is powered, verify that LED4 (Power LED) is ON (green). Additionally, verify that LED3 (Status LED) is blinking (green) to confirm the sink mode functionality.
- 3 (Optional): Connect a DC load (with 20 V and less than 14 W of power) to the output terminal (J9 - green color) of the EVAL_PMG1_B1_DRP kit. Verify that the output voltage is 20 V across the test points TP10 (+ve) and TP9 (GND) using a multimeter.

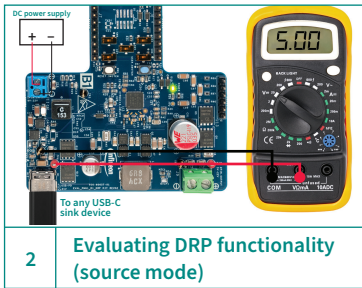

Step 2: Evaluating DRP functionality (source mode)

- 1 Disconnect all connections from the previous step and connect a 12 V to 20 V DC power supply with up to 3 A current rating to the input DC terminal (J11 - blue color).
- 2 Connect the USB-C sink device (e.g., a USB-C capable phone or a laptop supporting USB-C charging) to the USB-C PD port (J10) using a USB-C cable.
- 3 Verify that LED4 (Power LED) is ON (green) to confirm that the board is powered and LED3 (Status LED) is ON (green) to confirm source mode functionality.
- 4 Verify the charging status on the connected device. Optionally, using a multimeter, measure the voltage between test points TP8 (+ve) and TP7 (GND). The voltage should either be 5 V or 9 V depending on the connected USB-C sink device.

Next steps

- Download and unzip the EVAL_PMG1_B1_DRP release package from the EVAL_PMG1_B1_DRP kit webpage (www.infineon.com/EVAL_PMG1_B1_DRP).
- See the EVAL_PMG1_B1_DRP kit user guide (available as part of the EVAL_PMG1_B1_DRP kit release package) to learn more about the kit features and how to develop applications using ModusToolbox™ software.

QR label to be placed on this box



X-ON Electronics

Largest Supplier of Electrical and Electronic Components

Click to view similar products for [Development Boards & Kits - ARM category](#):

Click to view products by [Infineon manufacturer](#):

Other Similar products are found below :

[CY4541](#) [OM13090UL](#) [YR0K77210B000BE](#) [B-U585I-IOT02A](#) [NUCLEO-WL55JC1](#) [ZDSD-Pinboard](#) [LKS32MC034DOF6Q8-k](#)
[LKS32MC077MBS8-K](#) [LKS32MC038Y6P8B-K](#) [LKS32MC071DOC8T8-K](#) [LKS32MC074DOF8Q8-K](#) [LKS32MC071CBT8-K](#)
[LKS32MC038Y6P8-k](#) [Ai-WB2-32S-Kit](#) [GD32E103T-START](#) [GD32L233K-START](#) [XDS601](#) [RP2040-Tiny](#) [M6G2C-256LI](#) [YT37](#)
[LKS32MC033H6P8B-K](#) [VC-02-Kit_EN](#) [Ra-08H-Kit](#) [Hi-12FL-Kit](#) [PB-03M-Kit](#) [Ai-WB2-13-Kit](#) [PB-03F-Kit](#) [Ra-08-Kit](#) [Hi-07SL-Kit](#) [Hi-](#)
[07S-Kit](#) [Ai-WB2-12F-Kit](#) [PB-03-Kit](#) [Hi-12F-Kit](#) [AT-START-F407](#) [E104-BT40-TB](#) [APM32F072VBT6](#) [APM32F091VC MINI](#)
[APM32F407IG-MINIBOARD](#) [APM32F051R8 MINI](#) [GD32FPRT-START](#) [GD32407H-START-1](#) [GD32E503V-EVAL](#) [GD32E507R-START](#)
[GD32403V-START-1](#) [EPC1EVK-ECGPPG\(FS\)](#) [NS4EVKA-LC](#) [ENS1EVKD](#) [.ENS1EVKB](#) [ENS1EVKE](#) [HLK-7621-ALL-SUIT](#)