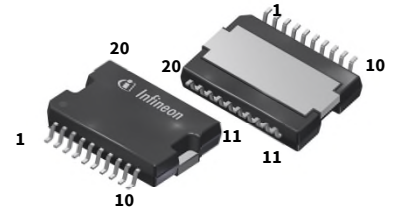


# IGO60R070D1

## 600V CoolGaN™ enhancement-mode Power Transistor

### Features

- Enhancement mode transistor – Normally OFF switch
- Ultra fast switching
- No reverse-recovery charge
- Capable of reverse conduction
- Low gate charge, low output charge
- Superior commutation ruggedness
- Qualified for industrial applications according to JEDEC Standards (JESD47 and JESD22)



### Benefits

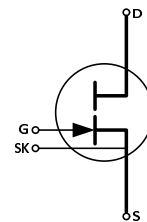
- Improves system efficiency
- Improves power density
- Enables higher operating frequency
- System cost reduction savings
- Reduces EMI

|               |                         |
|---------------|-------------------------|
| Gate          | 9, 10                   |
| Drain         | 13,14,15,16,17,18       |
| Kelvin Source | 8                       |
| Source        | 1,2,3,4,5,6,7, heatslug |
| not connected | 11,12,19,20             |

### Applications

Industrial, telecom, datacenter SMPS based on the half-bridge topology (half-bridge topologies for hard and soft switching such as Totem pole PFC, high frequency LLC).

**For other applications:** review CoolGaN™ reliability white paper and contact Infineon regional support



**Table 1 Key Performance Parameters at T<sub>j</sub> = 25 °C**

| Parameter                | Value | Unit |
|--------------------------|-------|------|
| V <sub>DS,max</sub>      | 600   | V    |
| R <sub>DS(on),max</sub>  | 70    | mΩ   |
| Q <sub>G,typ</sub>       | 5.8   | nC   |
| I <sub>D,pulse</sub>     | 60    | A    |
| Q <sub>oss @ 400 V</sub> | 41    | nC   |
| Q <sub>rr</sub>          | 0     | nC   |



**Table 2 Ordering Information**

| Type / Ordering Code | Package      | Marking  | Related links  |
|----------------------|--------------|----------|----------------|
| IGO60R070D1          | PG-DSO-20-85 | 60R070D1 | see Appendix A |

## Table of Contents

|  |           |
|--|-----------|
| <b>Features.....</b>                                     | <b>1</b>  |
| <b>Benefits .....</b>                                    | <b>1</b>  |
| <b>Applications.....</b>                                 | <b>1</b>  |
| <b>Table of Contents .....</b>                           | <b>2</b>  |
| <b>1       Maximum ratings.....</b>                      | <b>3</b>  |
| <b>2       Thermal characteristics.....</b>              | <b>4</b>  |
| <b>3       Electrical characteristics .....</b>          | <b>5</b>  |
| <b>4       Electrical characteristics diagrams .....</b> | <b>7</b>  |
| <b>5       Test Circuits .....</b>                       | <b>13</b> |
| <b>6       Package Outlines .....</b>                    | <b>14</b> |
| <b>7       Appendix A.....</b>                           | <b>15</b> |
| <b>8       Revision History .....</b>                    | <b>16</b> |

# 1 Maximum ratings

at  $T_j = 25\text{ °C}$ , unless otherwise specified. Continuous application of maximum ratings can deteriorate transistor lifetime. For further information, contact your local Infineon sales office.

**Table 3 Maximum ratings**

| Parameter   | Symbol         | Values |      |      | Unit | Note/Test Condition   |
|---|----------------|--------|------|------|------|---|
|   |                | Min.   | Typ. | Max. |      |   |
| Drain source voltage, continuous <sup>1</sup>           | $V_{DS,max}$   | -      | -    | 600  | V    | $V_{GS} = 0\text{ V}$   |
| Drain source destructive breakdown voltage <sup>2</sup> | $V_{DS,bd}$    | 800    | -    | -    | V    | $V_{GS} = 0\text{ V}$ , $I_{DS} = 12.2\text{ mA}$   |
| Drain source voltage, pulsed <sup>2</sup>               | $V_{DS,pulse}$ | -      | -    | 750  | V    | $T_j = 25\text{ °C}$ ; $V_{GS} \leq 0\text{ V}$ ; $\leq 1$ hour of total time   |
|   |                | -      | -    | 650  | V    | $T_j = 125\text{ °C}$ , $V_{GS} \leq 0\text{ V}$ ; $\leq 1$ hour of total time  |
| Switching surge voltage, pulsed <sup>2</sup>            | $V_{DS,surge}$ | -      | -    | 750  | V    | DC bus voltage = 700 V; turn off $V_{DS,pulse} = 750\text{ V}$ ; turn on $I_{D,pulse} = 27\text{ A}$ ; $T_j = 105\text{ °C}$ ; $f \leq 100\text{ kHz}$ , $t \leq 100\text{ secs}$ (10 million pulses) |
| Continuous current, drain source                        | $I_D$          | -      | -    | 31   | A    | $T_C = 25\text{ °C}$ ; $T_j = T_{j,max}$<br>$T_C = 100\text{ °C}$ ; $T_j = T_{j,max}$<br>$T_C = 125\text{ °C}$ ; $T_j = T_{j,max}$  |
|   |                | -      | -    | 20   |      |   |
|   |                | -      | -    | 14   |      |   |
| Pulsed current, drain source <sup>3,4</sup>             | $I_{D,pulse}$  | -      | -    | 60   | A    | $T_C = 25\text{ °C}$ ; $I_G = 26.1\text{ mA}$ ; See Figure 3; Figure 5;   |
| Pulsed current, drain source <sup>4,5</sup>             | $I_{D,pulse}$  | -      | -    | 35   | A    | $T_C = 125\text{ °C}$ ; $I_G = 26.1\text{ mA}$ ; See Figure 4; Figure 6;  |
| Gate current, continuous <sup>4,5,6</sup>               | $I_{G,avg}$    | -      | -    | 20   | mA   | $T_j = -55\text{ °C}$ to $150\text{ °C}$ ;  |
| Gate current, pulsed <sup>4,6</sup>                     | $I_{G,pulse}$  | -      | -    | 2000 | mA   | $T_j = -55\text{ °C}$ to $150\text{ °C}$ ;<br>$t_{PULSE} = 50\text{ ns}$ , $f = 100\text{ kHz}$   |
| Gate source voltage, continuous <sup>6</sup>            | $V_{GS}$       | -10    | -    | -    | V    | $T_j = -55\text{ °C}$ to $150\text{ °C}$ ;  |
| Gate source voltage, pulsed <sup>6</sup>                | $V_{GS,pulse}$ | -25    | -    | -    | V    | $T_j = -55\text{ °C}$ to $150\text{ °C}$ ;<br>$t_{PULSE} = 50\text{ ns}$ , $f = 100\text{ kHz}$ ;<br>open drain   |
| Power dissipation                                       | $P_{tot}$      | -      | -    | 125  | W    | $T_C = 25\text{ °C}$  |
| Operating temperature                                   | $T_j$          | -55    | -    | 150  | °C   |   |

<sup>1</sup> All devices are 100% tested at  $I_{DS} = 12.2\text{ mA}$  to assure  $V_{DS} \geq 800\text{ V}$

<sup>2</sup> Provided as measure of robustness under abnormal operating conditions and not recommended for normal operation

<sup>3</sup> Limits derived from product characterization, parameter not measured during production

<sup>4</sup> Ensure that average gate drive current,  $I_{G,avg}$  is  $\leq 20\text{ mA}$ . Please see figure 27 for  $I_{G,avg}$ ,  $I_{G,pulse}$  and  $I_G$  details

<sup>5</sup> Parameter is influenced by rel-requirements. Please contact the local Infineon Sales Office to get an assessment of your application

<sup>6</sup> We recommend using an advanced driving technique to optimize the device performance. Please see gate drive app note for details

|                                |           |     |   |     |      |   |
|--------------------------------|-----------|-----|---|-----|------|---|
| Storage temperature            | $T_{stg}$ | -55 | - | 150 | °C   | Max shelf life depends on storage conditions. |
| Drain-source voltage slew-rate | $dV/dt$   |     |   | 200 | V/ns |   |

## 2 Thermal characteristics

**Table 4 Thermal characteristics**

| Parameter                         | Symbol     | Values |      |      | Unit | Note/Test Condition |
|-----------------------------------|------------|--------|------|------|------|---------------------|
|                                   |            | Min.   | Typ. | Max. |      |                     |
| Thermal resistance, junction-case | $R_{thJC}$ | -      | -    | 1    | °C/W |                     |
| Reflow soldering temperature      | $T_{sold}$ | -      | -    | 245  | °C   | MSL3                |

### 3 Electrical characteristics

at  $T_j = 25\text{ °C}$ , unless specified otherwise

**Table 5 Static characteristics**

| Parameter   | Symbol       | Values     |                |            | Unit          | Note/Test Condition   |
|---|--------------|------------|----------------|------------|---------------|---|
|   |              | Min.       | Typ.           | Max.       |               |   |
| Gate threshold voltage  | $V_{GS(th)}$ | 0.9<br>0.7 | 1.2<br>1.0     | 1.6<br>1.4 | V             | $I_{DS} = 2.6\text{ mA}; V_{DS} = 10\text{ V}; T_j = 25\text{ °C}$<br>$I_{DS} = 2.6\text{ mA}; V_{DS} = 10\text{ V}; T_j = 125\text{ °C}$ |
| Drain-Source leakage current  | $I_{DSS}$    | -<br>-     | 1<br>20        | 100<br>-   | $\mu\text{A}$ | $V_{DS} = 600\text{ V}; V_{GS} = 0\text{ V}; T_j = 25\text{ °C}$<br>$V_{DS} = 600\text{ V}; V_{GS} = 0\text{ V}; T_j = 150\text{ °C}$     |
| Drain-Source leakage current at application conditions <sup>1</sup> | $I_{DSSapp}$ | -          | 60             | -          | $\mu\text{A}$ | $V_{DS} = 400\text{ V}; V_{GS} = 0\text{ V}; T_j = 125\text{ °C}$   |
| Gate-Source leakage current   | $I_{GSS}$    | -1<br>-1   | -<br>-         | -<br>-     | mA            | $V_{DS} = 0\text{ V}; V_{GS} = -10\text{ V}; T_j = 25\text{ °C}$<br>$V_{DS} = 0\text{ V}; V_{GS} = -10\text{ V}; T_j = 125\text{ °C}$     |
| Drain-Source on-state resistance                                    | $R_{DS(on)}$ | -<br>-     | 0.055<br>0.100 | 0.070<br>- | $\Omega$      | $I_G = 26.1\text{ mA}; I_D = 8\text{ A}; T_j = 25\text{ °C}$<br>$I_G = 26.1\text{ mA}; I_D = 8\text{ A}; T_j = 150\text{ °C}$             |
| Gate resistance   | $R_{G,int}$  | -          | 0.78           | -          | $\Omega$      | LCR impedance measurement;<br>$f = f_{res}$ ; open drain;   |

**Table 6 Dynamic characteristics**

| Parameter   | Symbol       | Values |       |      | Unit | Note/Test Condition   |
|---|--------------|--------|-------|------|------|---|
|   |              | Min.   | Typ.  | Max. |      |   |
| Input capacitance   | $C_{iss}$    | -      | 380   | -    | pF   | $V_{GS} = 0\text{ V}; V_{DS} = 400\text{ V};$<br>$f = 1\text{ MHz}$               |
| Output capacitance  | $C_{oss}$    | -      | 72    | -    | pF   | $V_{GS} = 0\text{ V}; V_{DS} = 400\text{ V};$<br>$f = 1\text{ MHz}$               |
| Reverse Transfer capacitance                              | $C_{rss}$    | -      | 0.3   | -    | pF   | $V_{GS} = 0\text{ V}; V_{DS} = 400\text{ V};$<br>$f = 1\text{ MHz}$               |
| Effective output capacitance, energy related <sup>2</sup> | $C_{o(er)}$  | -      | 80    | -    | pF   | $V_{DS} = 0\text{ to }400\text{ V}$   |
| Effective output capacitance, time related <sup>3</sup>   | $C_{o(tr)}$  | -      | 102.5 | -    | pF   | $V_{GS} = 0\text{ V}; V_{DS} = 0\text{ to }400\text{ V};$<br>$I_D = \text{const}$ |
| Output charge   | $Q_{oss}$    | -      | 41    | -    | nC   | $V_{DS} = 0\text{ to }400\text{ V}$   |
| Turn- on delay time                                       | $t_{d(on)}$  | -      | 15    | -    | ns   | see Figure 23   |
| Turn- off delay time                                      | $t_{d(off)}$ | -      | 15    | -    | ns   | see Figure 23   |
| Rise time   | $t_r$        | -      | 9     | -    | ns   | see Figure 23   |
| Fall time   | $t_f$        | -      | 13    | -    | ns   | see Figure 23   |

<sup>1</sup> Parameter represents end of use leakage in applications

<sup>2</sup>  $C_{o(er)}$  is a fixed capacitance that gives the same stored energy as  $C_{oss}$  while  $V_{DS}$  is rising from 0 to 400 V

<sup>3</sup>  $C_{o(tr)}$  is a fixed capacitance that gives the same charging time as  $C_{oss}$  while  $V_{DS}$  is rising from 0 to 400 V

**Table 7 Gate charge characteristics**

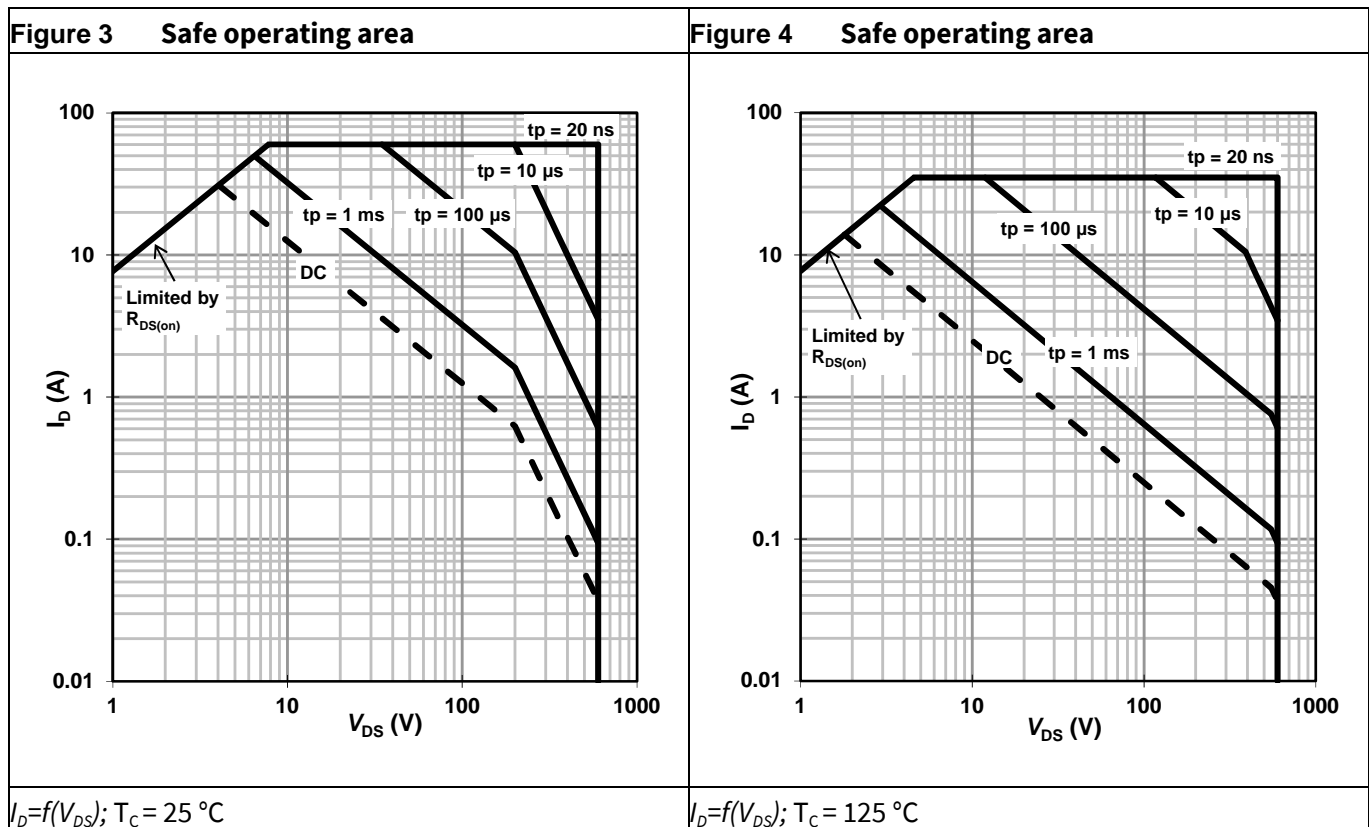
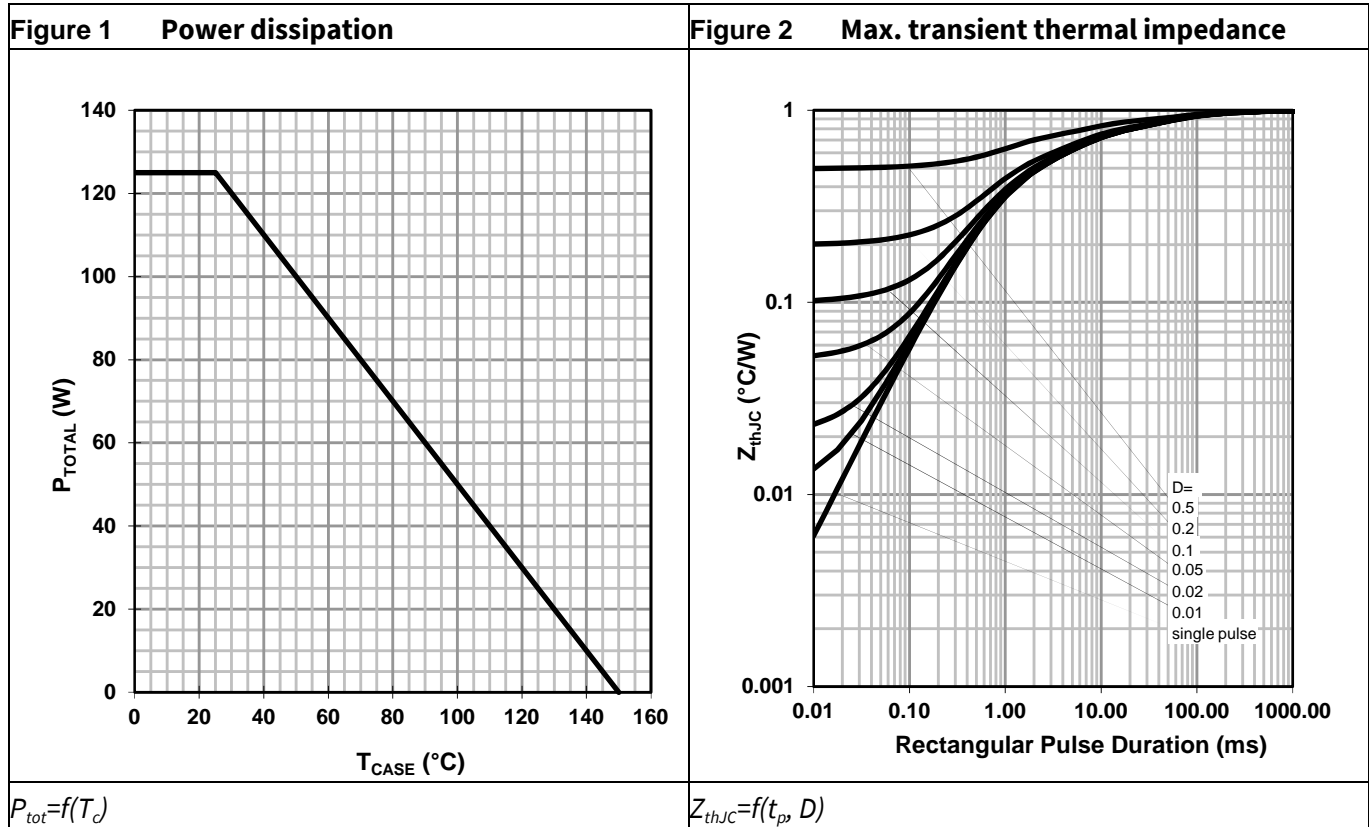
| Parameter   | Symbol | Values |      |      | Unit | Note/Test Condition                                     |
|-------------|--------|--------|------|------|------|---|
|             |        | Min.   | Typ. | Max. |      |   |
| Gate charge | $Q_G$  | -      | 5.8  | -    | nC   | $I_{GS} = 0$ to 10 mA; $V_{DS} = 400$ V;<br>$I_D = 8$ A |

**Table 8 Reverse conduction characteristics**

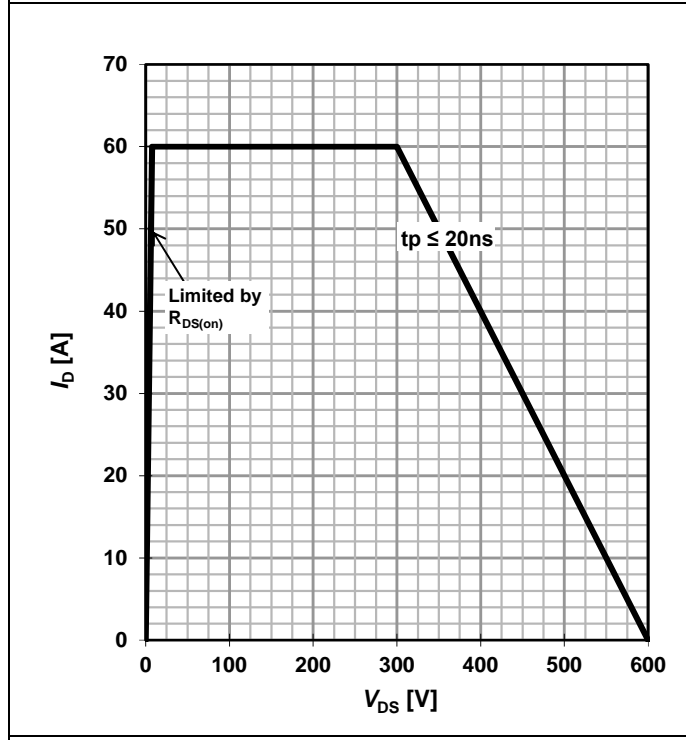
| Parameter                     | Symbol        | Values |      |      | Unit | Note/Test Condition            |
|-------------------------------|---------------|--------|------|------|------|--------------------------------|
|                               |               | Min.   | Typ. | Max. |      |                                |
| Source-Drain reverse voltage  | $V_{SD}$      | -      | 2.2  | 2.5  | V    | $V_{GS} = 0$ V; $I_{SD} = 8$ A |
| Pulsed current, reverse       | $I_{S,pulse}$ | -      | -    | 60   | A    | $I_G = 26.1$ mA                |
| Reverse recovery charge       | $Q_{rr}^1$    | -      | 0    | -    | nC   | $I_S = 8$ A, $V_{DS} = 400$ V  |
| Reverse recovery time         | $t_{rr}$      | -      | 0    | -    | ns   |                                |
| Peak reverse recovery current | $I_{rrm}$     | -      | 0    | -    | A    |                                |

## 4 Electrical characteristics diagrams

at  $T_j = 25\text{ }^\circ\text{C}$ , unless specified otherwise

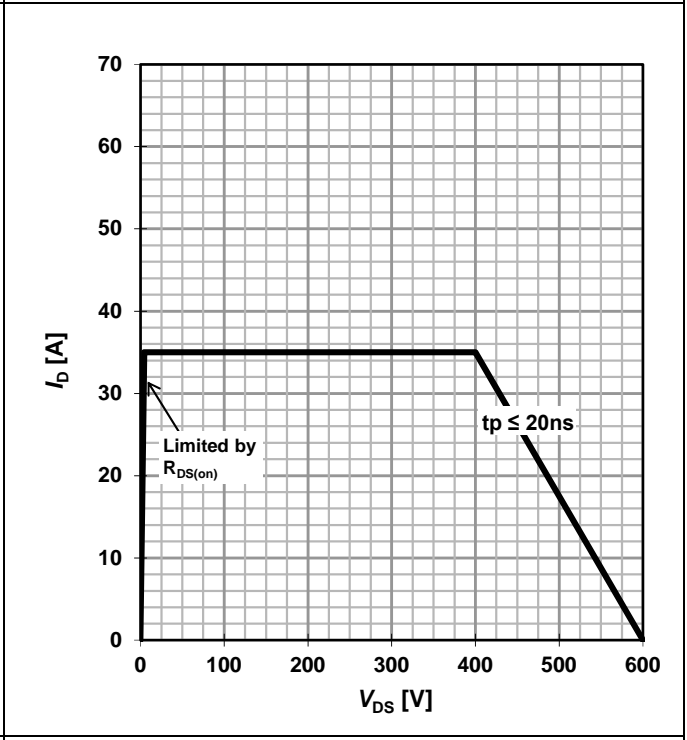


**Figure 5 Repetitive safe operating area<sup>1</sup>**



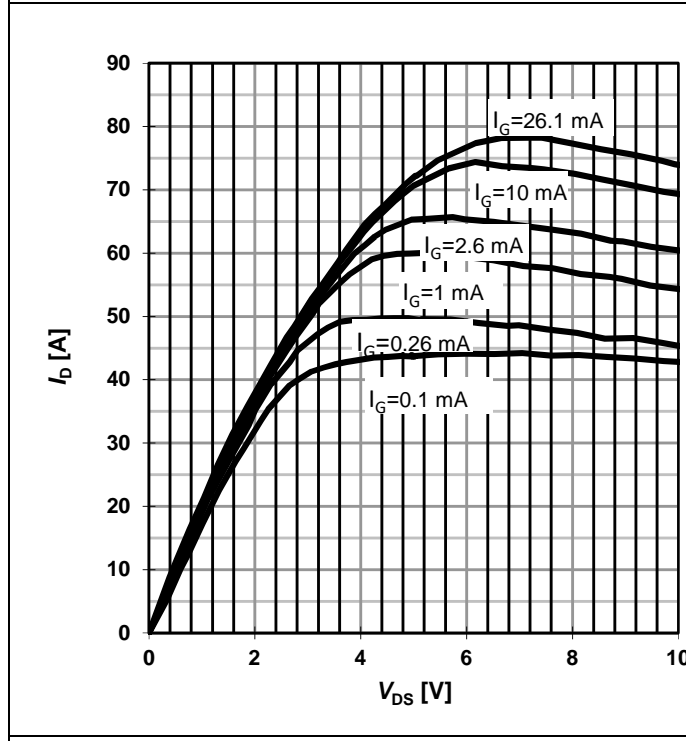
$T_c = 25\text{ °C}; T_j \leq 150\text{ °C}$

**Figure 6 Repetitive safe operating area<sup>1</sup>**



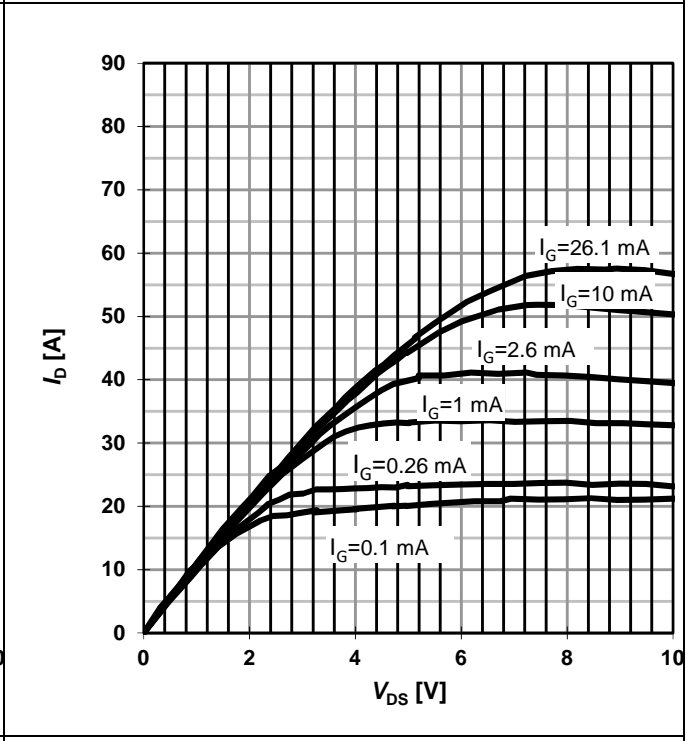
$T_c = 125\text{ °C}; T_j \leq 150\text{ °C}$

**Figure 7 Typ. output characteristics**



$I_D = f(V_{DS}, I_G); T_j = 25\text{ °C}$

**Figure 8 Typ. output characteristics**

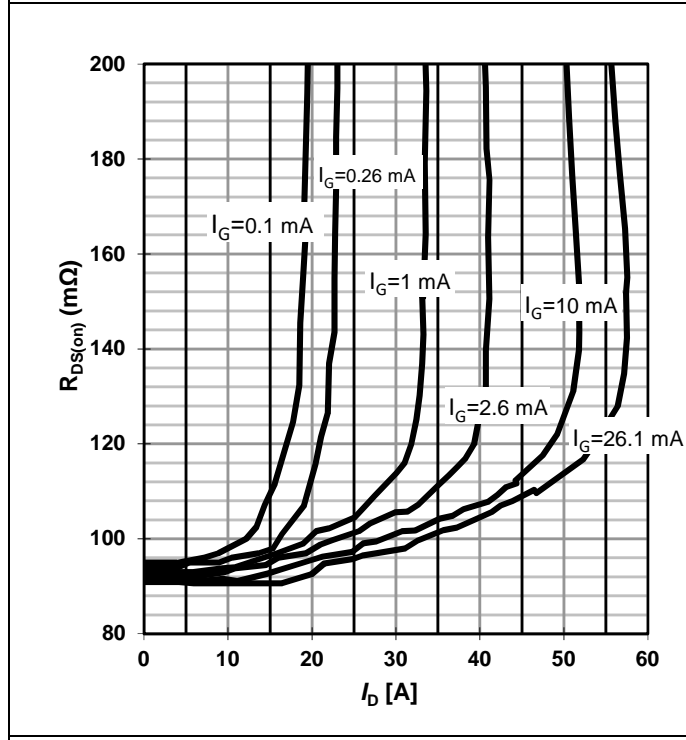


$I_D = f(V_{DS}, I_G); T_j = 125\text{ °C}$

<sup>1</sup> Parameter is influenced by rel-requirements. Please contact the local Infineon Sales Office to get an assessment of your application.

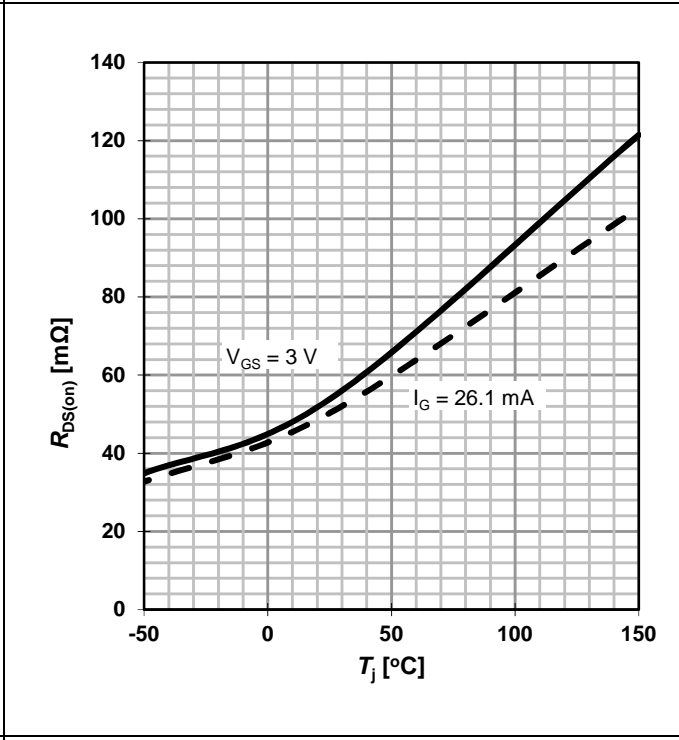


**Figure 9 Typ. Drain-source on-state resistance**



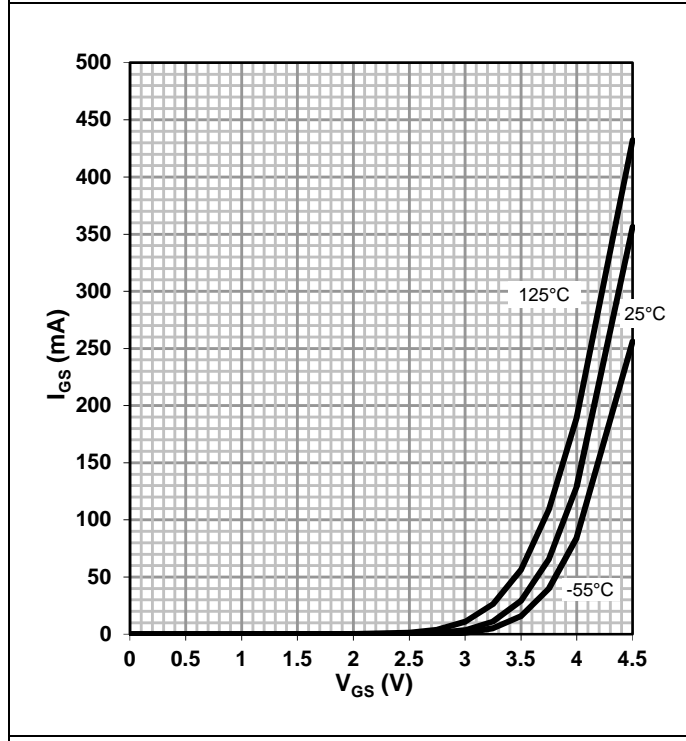
$R_{DS(on)} = f(I_D, I_G); T_j = 125^\circ C$

**Figure 10 Drain-source on-state resistance**



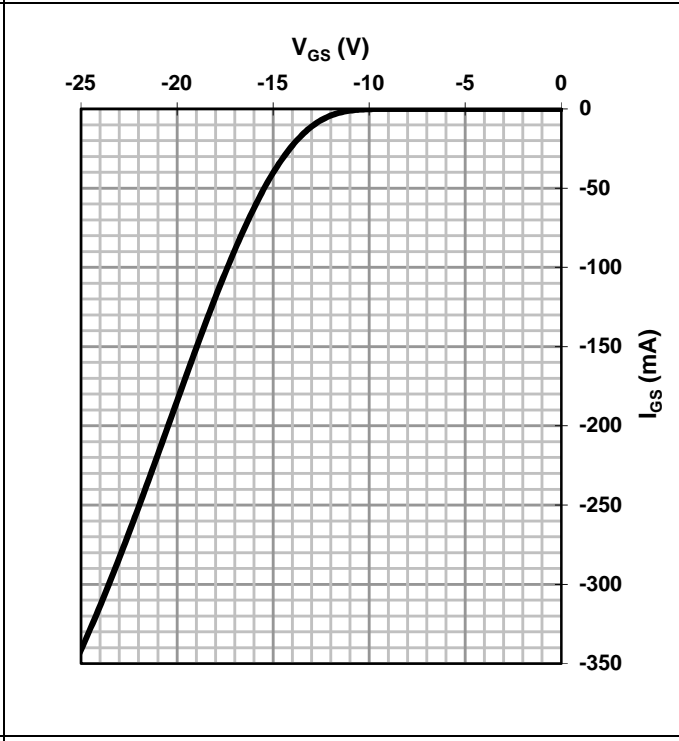
$R_{DS(on)} = f(T_j); I_D = 8 A$

**Figure 11 Typ. gate characteristics forward**



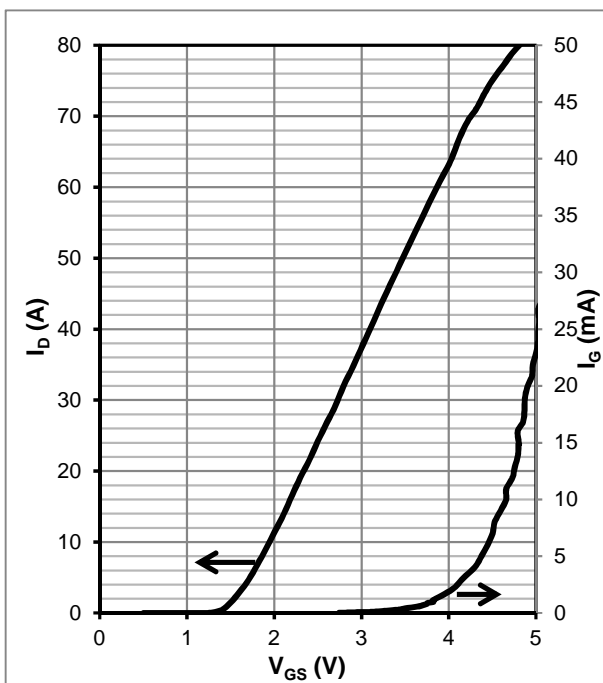
$I_{GS} = f(V_{GS}, T_j); \text{open drain}$

**Figure 12 Typ. gate characteristics reverse**



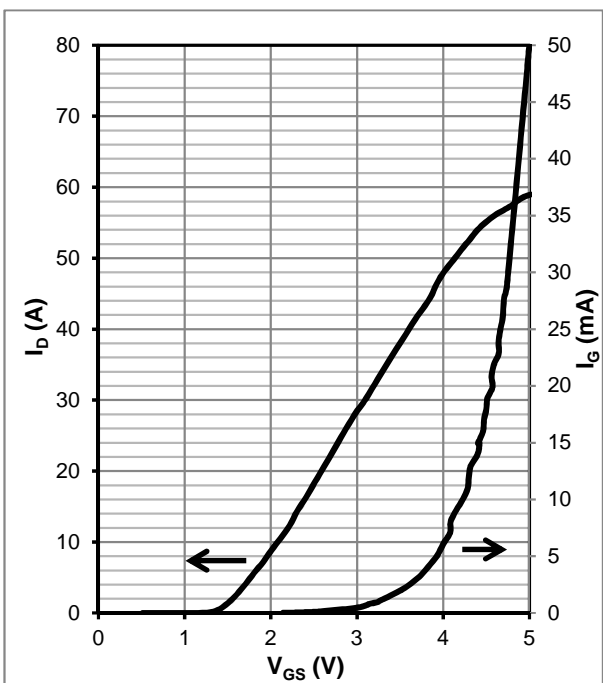
$I_{GS} = f(V_{GS}); T_j = 25^\circ C$

Figure 13 Typ. transfer characteristics



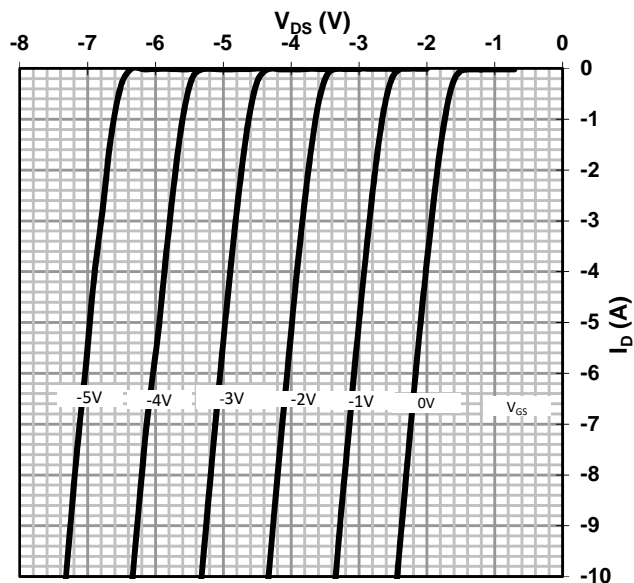
$I_D, I_G = f(V_{GS}); V_{DS} = 8\text{ V}; T_j = 25\text{ }^\circ\text{C}$

Figure 14 Typ. transfer characteristics



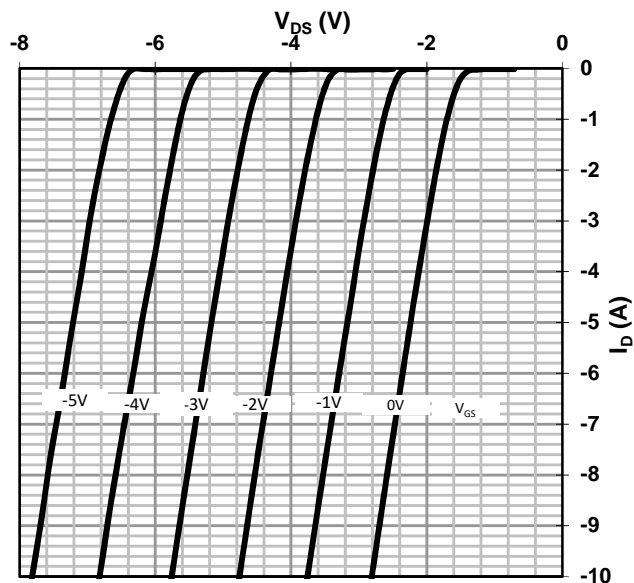
$I_D, I_G = f(V_{GS}); V_{DS} = 8\text{ V}; T_j = 125\text{ }^\circ\text{C}$

Figure 15 Typ. channel reverse characteristics



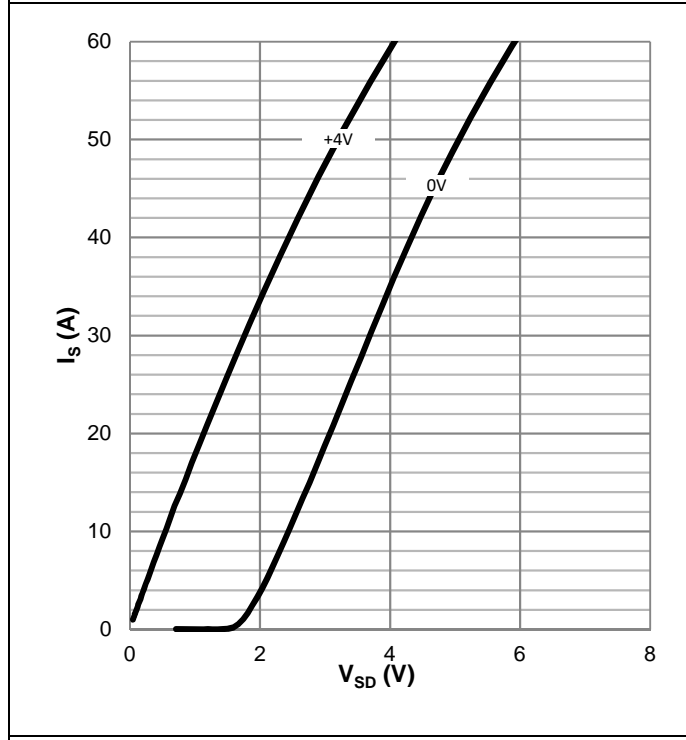
$V_{DS} = f(I_D, V_{GS}); T_j = 25\text{ }^\circ\text{C}$

Figure 16 Typ. channel reverse characteristics



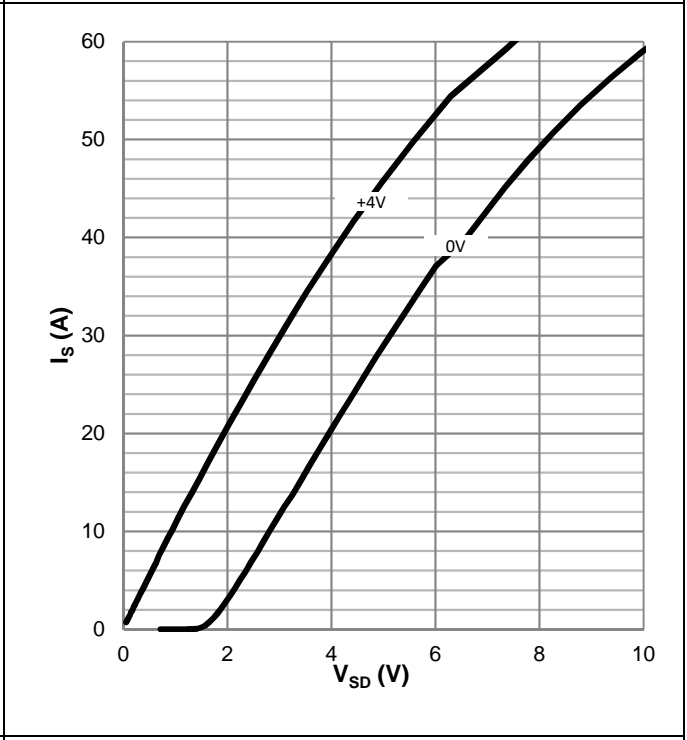
$V_{DS} = f(I_D, V_{GS}); T_j = 125\text{ }^\circ\text{C}$

**Figure 17** Typ. channel reverse characteristics



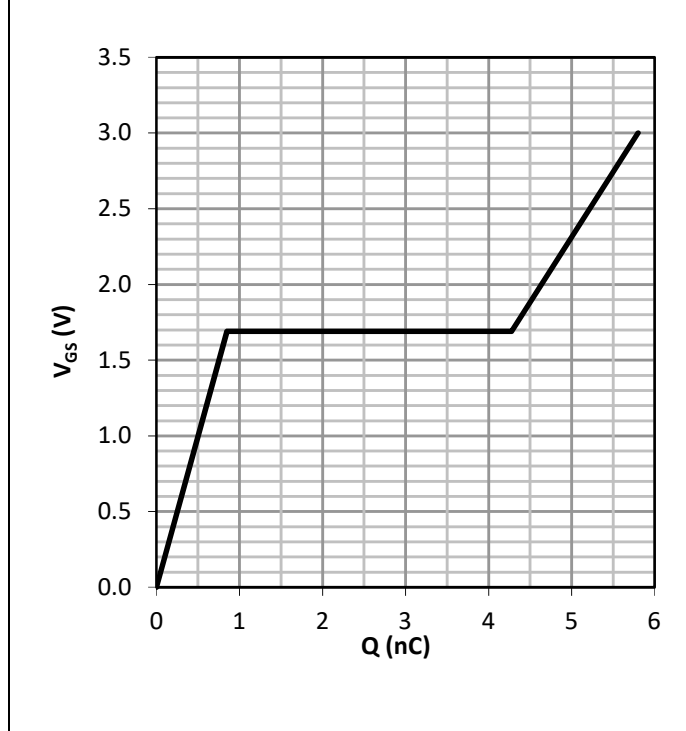
$I_D = f(V_{DS}, V_{GS}); T_j = 25\text{ °C}$

**Figure 18** Typ. channel reverse characteristics



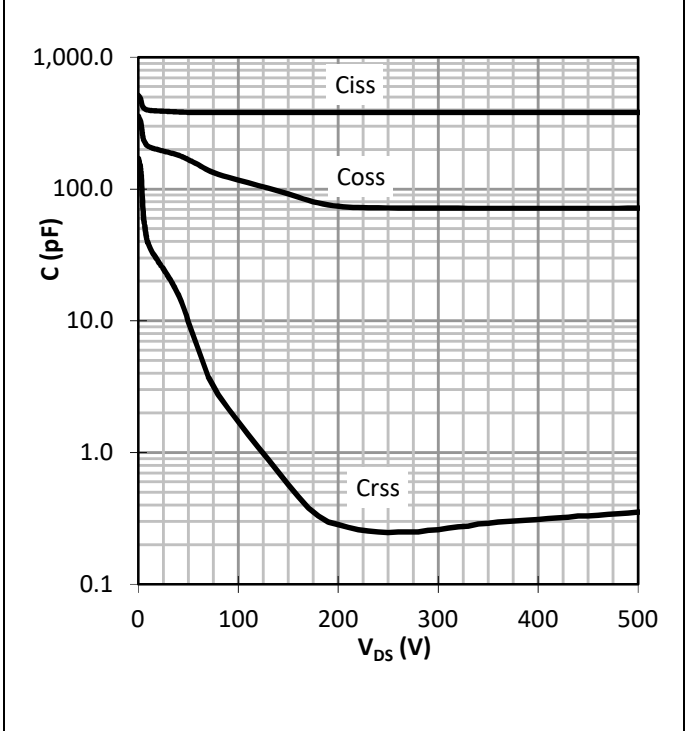
$I_D = f(V_{DS}, V_{GS}); T_j = 125\text{ °C}$

**Figure 19** Typ. gate charge



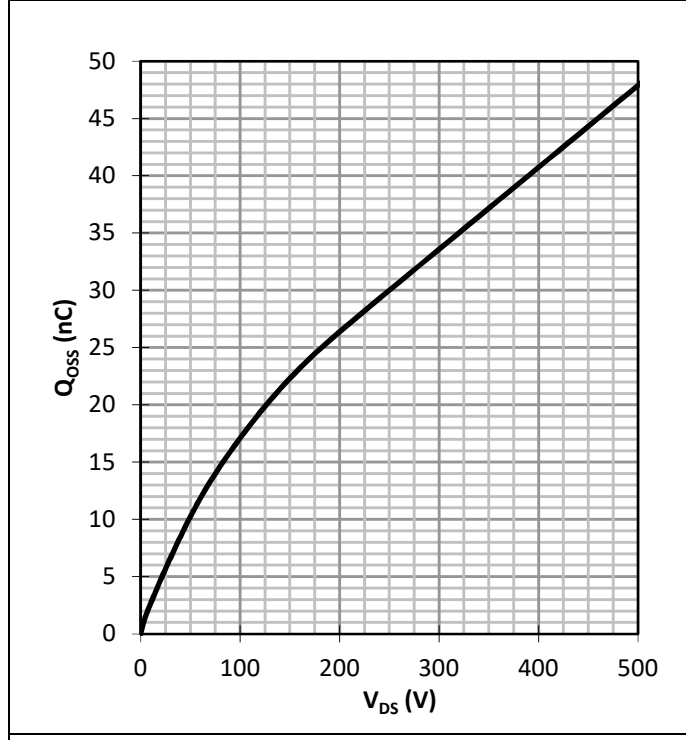
$V_{GS} = f(Q_G); V_{DCLINK} = 400\text{ V}; I_D = 8\text{ A}$

**Figure 20** Typ. capacitances



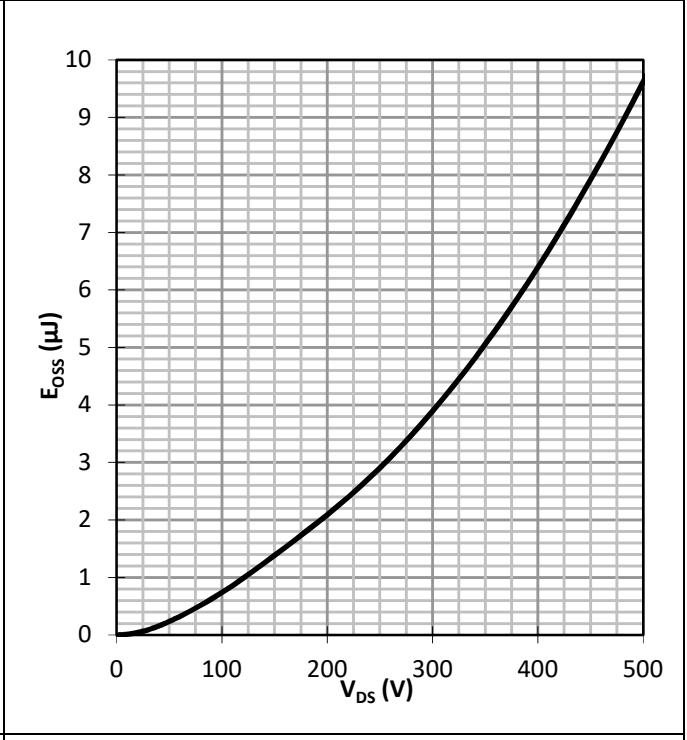
$C_{xss} = f(V_{DS})$

**Figure 21 Typ. output charge**



$Q_{Oss} = f(V_{Ds})$

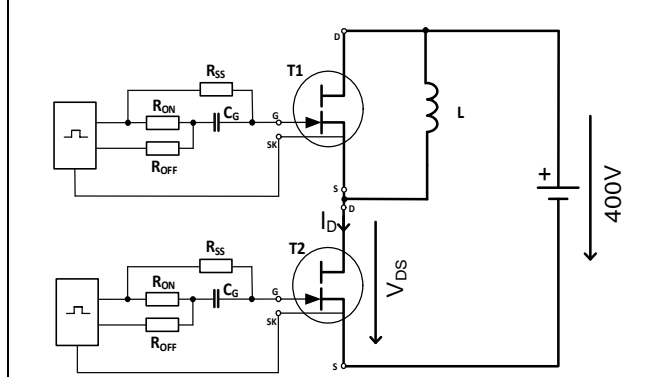
**Figure 22 Typ. Coss stored Energy**



$E_{Oss} = f(V_{Ds})$

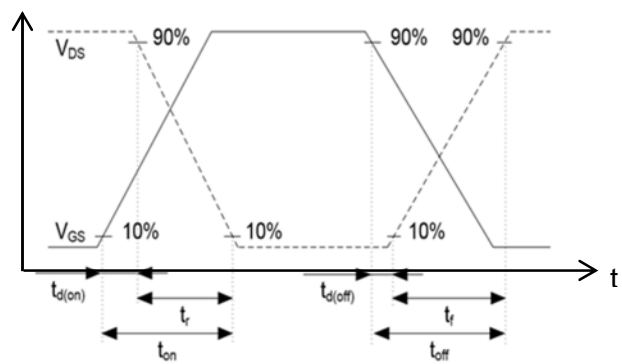
## 5 Test Circuits

**Figure 23 Switching times with inductive load**

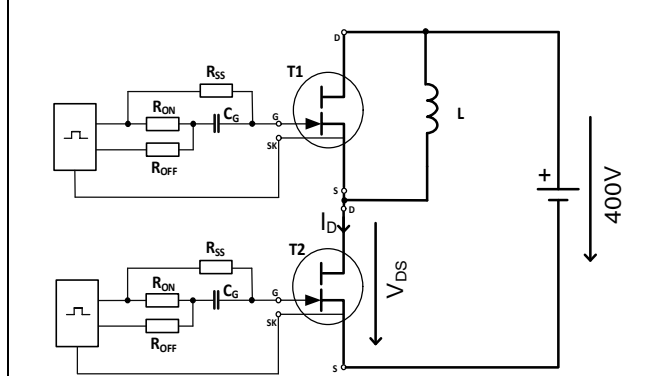


$I_D = 8A$ ,  $R_{ON} = 10\ \Omega$ ;  $R_{OFF} = 10\ \Omega$ ;  $R_{SS} = 820\ \Omega$ ;  $C_G = 2\ nF$ ;  
 $V_{DRV} = 12V$

**Figure 24 Switching times waveform**

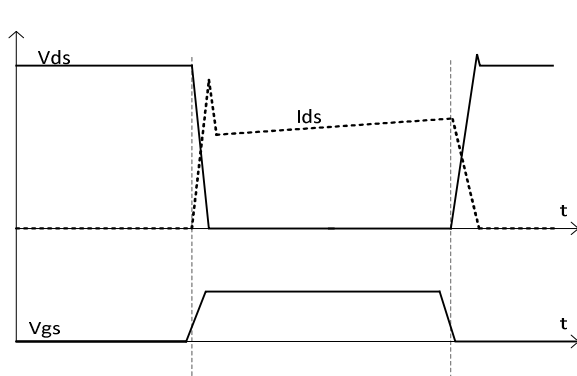


**Figure 25 Reverse Channel Characteristics Test**



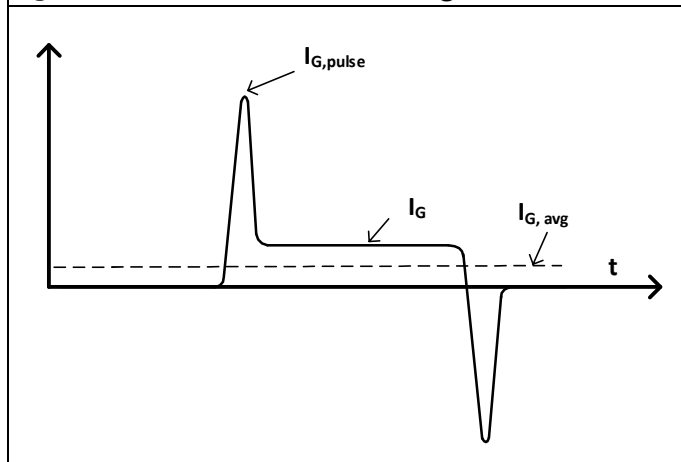
$I_D = 8A$ ,  $R_{ON} = 10\ \Omega$ ;  $R_{OFF} = 10\ \Omega$ ;  $R_{SS} = 820\ \Omega$ ;  $C_G = 2\ nF$ ;  
 $V_{DRV} = 12V$

**Figure 26 Typical Reverse Channel Recovery**



The recovery charge is  $Q_{OSS}$  only, no additional  $Q_{rr}$

**Figure 27 Gate current switching waveform**



## 6 Package Outlines

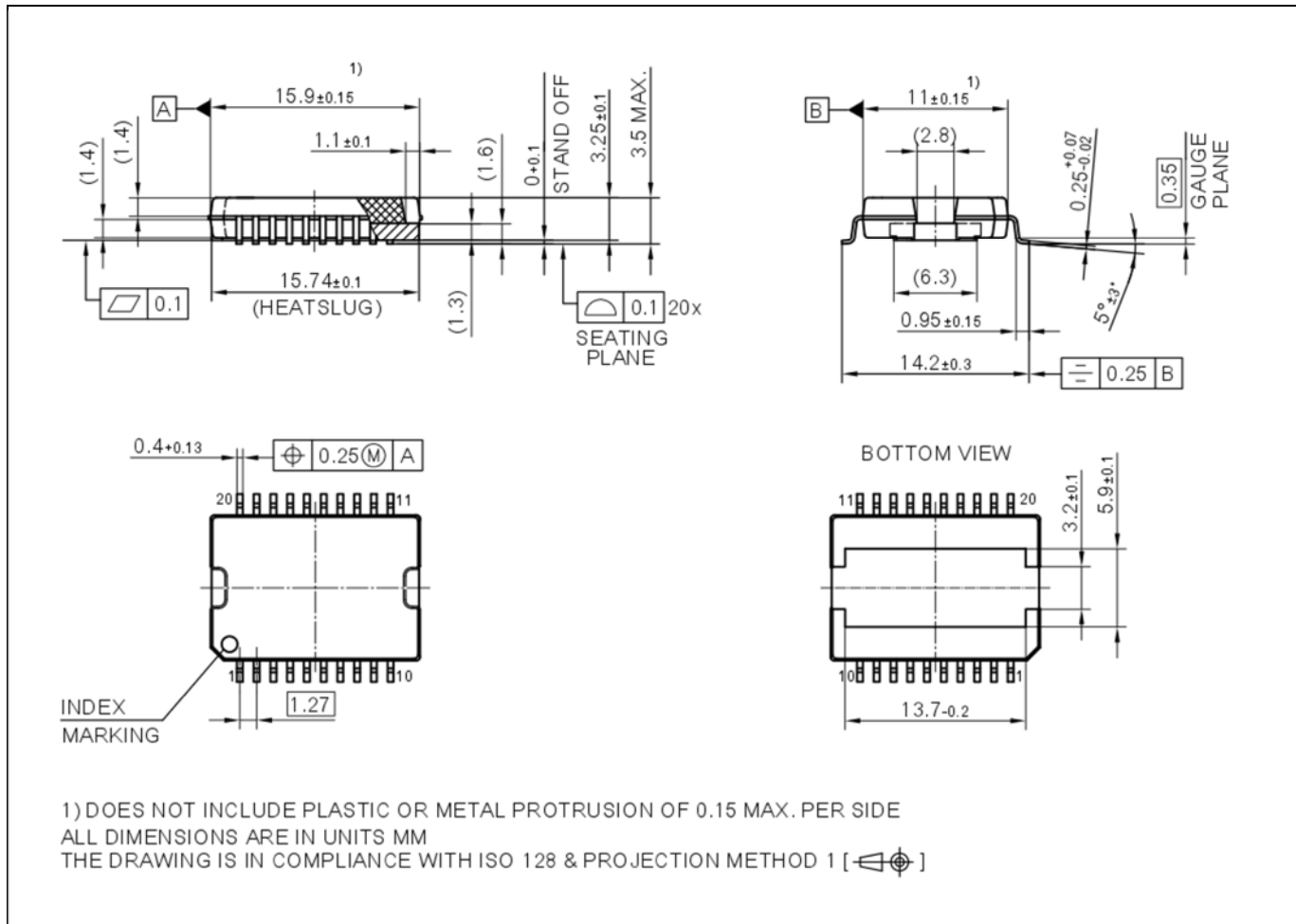


Figure 28 PG-DSO-20-85 Package Outline, dimensions (mm)

## 7 Appendix A

Table 9 Related links

- IFX CoolGaN™ webpage: [www.infineon.com/why-coolgan](http://www.infineon.com/why-coolgan)
- IFX CoolGaN™ reliability white paper: [www.infineon.com/gan-reliability](http://www.infineon.com/gan-reliability)
- IFX CoolGaN™ gate drive application note: [www.infineon.com/driving-coolgan](http://www.infineon.com/driving-coolgan)
- IFX CoolGaN™ applications information:
  - [www.infineon.com/gan-in-server-telecom](http://www.infineon.com/gan-in-server-telecom)
  - [www.infineon.com/gan-in-wirelesscharging](http://www.infineon.com/gan-in-wirelesscharging)
  - [www.infineon.com/gan-in-audio](http://www.infineon.com/gan-in-audio)
  - [www.infineon.com/gan-in-adapter-charger](http://www.infineon.com/gan-in-adapter-charger)

## 8 Revision History

### Major changes since the last revision

| Revision | Date       | Description of change   |
|----------|------------|---|
| 2.0      | 2018-04-24 | Final version release   |
| 2.1      | 2018-10-12 | Updated application section; added Appendix A and Fig. 27; updated maximum rating table footnotes, switching times and figures. |
| 2.11     | 2020-01-16 | Added $V_{DS,bd}$ , $V_{DS,pulse}$ , $V_{DS,surge}$ specifications in maximum ratings table of page3                            |



#### Trademarks of Infineon Technologies AG

$\mu$ HVIC™,  $\mu$ IPM™,  $\mu$ PFC™, AU-ConvertIR™, AURIX™, C166™, CanPAK™, CIPOS™, CIPURSE™, CoolDP™, CoolGaN™, COOLiR™, CoolMOS™, CoolSET™, CoolSiC™, DAVE™, DI-POL™, DirectFET™, DrBlade™, EasyPIM™, EconoBRIDGE™, EconoDUAL™, EconoPACK™, EconoPIM™, EiceDRIVER™, eupec™, FCOS™, GaNpowIR™, HEXFET™, HITFET™, HybridPACK™, iMOTION™, IRAM™, ISOFACE™, IsoPACK™, LEDriviR™, LITIX™, MIPAQ™, ModSTACK™, my-d™, NovalithIC™, OPTIGA™, OptiMOS™, ORIGAT™, PowIRaudio™, PowIRstage™, PrimePACK™, PrimeSTACK™, PROFET™, PRO-SiL™, RASIC™, REAL3™, SmartLEWIS™, SOLID FLASH™, SPOC™, StrongIRFET™, SupIRBuck™, TEMPFET™, TRENCHSTOP™, TriCore™, UHVIC™, XHP™, XMC™

Trademarks updated November 2015

#### Other Trademarks

All referenced product or service names and trademarks are the property of their respective owners.

**Edition 2020-01-16**

**Published by**

**Infineon Technologies AG**

**81726 München, Germany**

**© 2020 Infineon Technologies AG.**

**All Rights Reserved.**

**Do you have a question about this document?**

**Email: [erratum@infineon.com](mailto:erratum@infineon.com)**

**Document reference**

**ifx1**

#### IMPORTANT NOTICE

The information given in this document shall in no event be regarded as a guarantee of conditions or characteristics ("Beschaffenheitsgarantie").

With respect to any examples, hints or any typical values stated herein and/or any information regarding the application of the product, Infineon Technologies hereby disclaims any and all warranties and liabilities of any kind, including without limitation warranties of non-infringement of intellectual property rights of any third party.

In addition, any information given in this document is subject to customer's compliance with its obligations stated in this document and any applicable legal requirements, norms and standards concerning customer's products and any use of the product of Infineon Technologies in customer's applications.

The data contained in this document is exclusively intended for technically trained staff. It is the responsibility of customer's technical departments to evaluate the suitability of the product for the intended application and the completeness of the product information given in this document with respect to such application.

For further information on the product, technology, delivery terms and conditions and prices please contact your nearest Infineon Technologies office ([www.infineon.com](http://www.infineon.com)).

#### WARNINGS

Due to technical requirements products may contain dangerous substances. For information on the types in question please contact your nearest Infineon Technologies office.

Except as otherwise explicitly approved by Infineon Technologies in a written document signed by authorized representatives of Infineon Technologies, Infineon Technologies' products may not be used in any applications where a failure of the product or any consequences of the use thereof can reasonably be expected to result in personal injury.

## X-ON Electronics

Largest Supplier of Electrical and Electronic Components

*Click to view similar products for [MOSFET](#) category:*

*Click to view products by [Infineon](#) manufacturer:*

Other Similar products are found below :

[614233C](#) [648584F](#) [IRFD120](#) [JANTX2N5237](#) [FCA20N60\\_F109](#) [FDZ595PZ](#) [2SK2545\(Q,T\)](#) [405094E](#) [423220D](#) [TPCC8103,L1Q\(CM](#)  
[MIC4420CM-TR](#) [VN1206L](#) [SBVS138LT1G](#) [614234A](#) [715780A](#) [NTNS3166NZT5G](#) [SSM6J414TU,LF\(T](#) [751625C](#) [BUK954R8-60E](#)  
[NTE6400](#) [SQJ402EP-T1-GE3](#) [2SK2614\(TE16L1,Q\)](#) [2N7002KW-FAI](#) [DMN1017UCP3-7](#) [EFC2J004NUZTDG](#) [ECH8691-TL-W](#)  
[FCAB21350L1](#) [P85W28HP2F-7071](#) [DMN1053UCP4-7](#) [NTE221](#) [NTE222](#) [NTE2384](#) [NTE2903](#) [NTE2941](#) [NTE2945](#) [NTE2946](#) [NTE2960](#)  
[NTE2967](#) [NTE2969](#) [NTE2976](#) [NTE455](#) [NTE6400A](#) [NTE2910](#) [NTE2916](#) [NTE2956](#) [NTE2911](#) [DMN2080UCB4-7](#) [TK10A80W,S4X\(S](#)  
[SSM6P69NU,LF](#) [DMP22D4UFO-7B](#)