

IR2086S(PbF)

HIGH SPEED, 100V, SELF OSCILLATING 50% DUTY CYCLE, FULL-BRIDGE DRIVER

Features

- Simple primary side control solution to enable full-bridge DC-Bus Converters for 48V distributed systems with reduced component count and board space.
- Frequency and dead time set by two external components
- Maximum 500KHz per channel output with 50% duty cycle
- Adjustable dead time 50nsec ~ 200nsec
- Floating channel designed for bootstrap operation up to +100Vdc
- High and low side pulse width matching to +/- 25nsec
- Overcurrent protection with adjustable hiccup period.
- Undervoltage lockout and internal soft start
- Part also available leadfree

Product Summary

| | |
|---|----------|
| $V_{CC(max)}$ | 25V |
| $V_{offset(max)}$ | 100Vdc |
| High/low side output freq (f_{osc}) | 500kHz |
| Output Current (I_O) | +/-1.2A |
| High/low side pulse edge matching | +/- 25ns |

Description

The IR2086S(PbF) is a self oscillating full-bridge controller and driver IC with 50% duty cycle ideally suited for 36V-75V full-bridge DC Bus Converters.

Dead time can be controlled through proper selection of C_T and can range from 50 to 200nsec. Internal soft start increases pulse width on power up and maintains equal pulse widths for the high and low outputs throughout the start up cycle. Undervoltage lockout prevents operation if V_{CC} is less than 7.5 Vdc. Over current shutdown occurs when the voltage on the C_s pin exceeds 200mV. Restart after overcurrent trip can be delayed by adjusting the external capacitor. The delay time ranges from 10 μ s to 1s.

Package

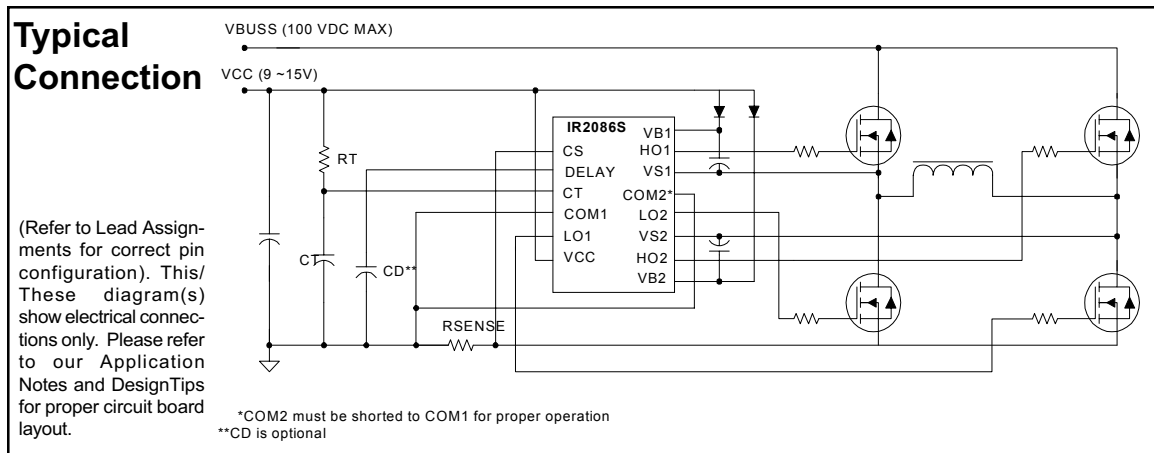

Absolute Maximum Ratings

V_{BIAS} (V_{CC} , V_{BS}) = 12V, C_L = 1000 pF, and T_A = 25°C unless otherwise specified.

Absolute maximum ratings indicate sustained limits beyond which damage to the device may occur. All voltage parameters are absolute voltages referenced to COM. All currents are defined positive into any lead. The thermal resistance and power dissipation ratings are measured under board mounted and still air conditions.

| Symbol | Definition | Min. | Max. | Units |
|-------------|--|------------------|------------------|-------|
| V_{CC} | Low side supply voltage | -0.3 | 25 | Vdc |
| $V_{B1,2}$ | High side floating supply voltage | -0.3 | 150 | |
| $V_{S1,2}$ | High side floating supply offset voltage | $V_{B1,2} - 25$ | $V_{B1,2} + 0.3$ | |
| $V_{HO1,2}$ | High side floating output voltage | $V_{B1,2} - 0.3$ | $V_{B1,2} + 0.3$ | |
| $V_{LO1,2}$ | Low side output voltage | -0.3 | $V_{CC} + 0.3$ | |
| V_{CT} | CT pin voltage | -0.3 | $V_{CC} + 0.3$ | |
| V_{CS} | Cs pin voltage | -0.3 | $V_{CC} + 0.3$ | |
| V_{DELAY} | Delay pin voltage | -0.3 | $V_{CC} + 0.3$ | |
| dV_S/dt | Allowable offset voltage slew rate | -50 | +50 | V/ns |
| I_{CC} | Supply current | — | 40 | mA |
| P_D | Package power dissipation (16-lead SOIC) | — | 1.0 | W |
| R_{thJA} | Thermal resistance, junction to ambient (16-lead SOIC) | — | 200 | °C/W |
| T_J | Junction temperature | -55 | 150 | °C |
| T_S | Storage temperature | -55 | 150 | |
| T_L | Lead temperature (soldering, 10 seconds) | — | 300 | |

Recommended Operating Conditions

For proper operation the device should be used within the recommended conditions.

| Symbol | Definition | Min. | Max. | Units |
|------------|---|------|------|-------|
| $V_{B1,2}$ | High side floating supply voltage | 9.5 | 15 | Vdc |
| $V_{S1,2}$ | Steady state high side floating supply offset voltage | -5 | 100 | |
| V_{CC} | Supply voltage | 9.5 | 15 | |
| I_{CC} | Supply current | — | 1 | mA |
| R_T | Timing resistor | 10 | 100 | Kohms |
| C_T | Timing capacitor | 47 | 1000 | pF |
| f_{max} | Operating frequency (per channel) | — | 500 | KHz |
| T_j | Junction temperature | -40 | 125 | °C |

Note1: Care should be taken to avoid output switching conditions where the Vs node flies inductively below ground by more than 5V.

Dynamic Electrical Characteristics

V_{BIAS} (V_{CC} , V_{BS}) = 12V, C_L = 1000 pF, and T_A = 25°C unless otherwise specified.

| Symbol | Definition | Min. | Typ. | Max. | Units | Test Conditions |
|---------------|-------------------------------|------|------|------|-------|--------------------------------|
| t_r | Turn-on rise time | — | 40 | 60 | nsec | $V_S = 0V$ |
| t_f | Turn-off fall time | — | 20 | 30 | | |
| f_{out} | Per channel output frequency | 440 | 500 | 580 | KHz | Ct=100pF, Rt=10Kohm |
| t_{dt} | High/low output dead time | 50 | — | — | nsec | |
| PM | High/low pulse width matching | — | — | 25 | | |
| t_{dcs} | Overcurrent shut down delay | — | 200 | — | | |
| $t_{restart}$ | Overcurrent restart delay | — | 0.5 | — | sec | $V_{cc} = 15V$, $C_d = 100nF$ |

Static Electrical Characteristics

V_{BIAS} (V_{CC} , V_{BS}) = 12V, C_L = 1000 pF and T_A = 25°C unless otherwise specified.

| Symbol | Definition | Min. | Typ. | Max. | Units | Test Conditions |
|-------------|---|------|------|------|---------|-----------------|
| $V_{OH1,2}$ | High level output voltage, ($V_{BIAS} - V_O$) | — | — | 1.5 | V | |
| $V_{OL1,2}$ | Low level output voltage | — | — | 0.1 | | |
| I_{leak} | Offset supply leakage current | — | — | 50 | μA | |
| I_{QBS} | Quiescent V_{BS} supply current | — | — | 150 | | |
| I_{QCC} | Quiescent V_{CC} supply current | — | — | 1.75 | mA | |
| V_{CS+} | Overcurrent shutdown threshold | 200 | 270 | 350 | mV | |
| U_{VCC+} | Undervoltage positive going threshold | 6.5 | 7.25 | 8.0 | V | |
| U_{VCC-} | Undervoltage negative going threshold | 6.0 | 6.8 | 7.7 | | |
| I_{O+} | Output high short circuit current | — | 1.2 | — | A | |
| I_{O-} | Output low short circuit current | — | 1.2 | — | | |

Functional Block Diagrams

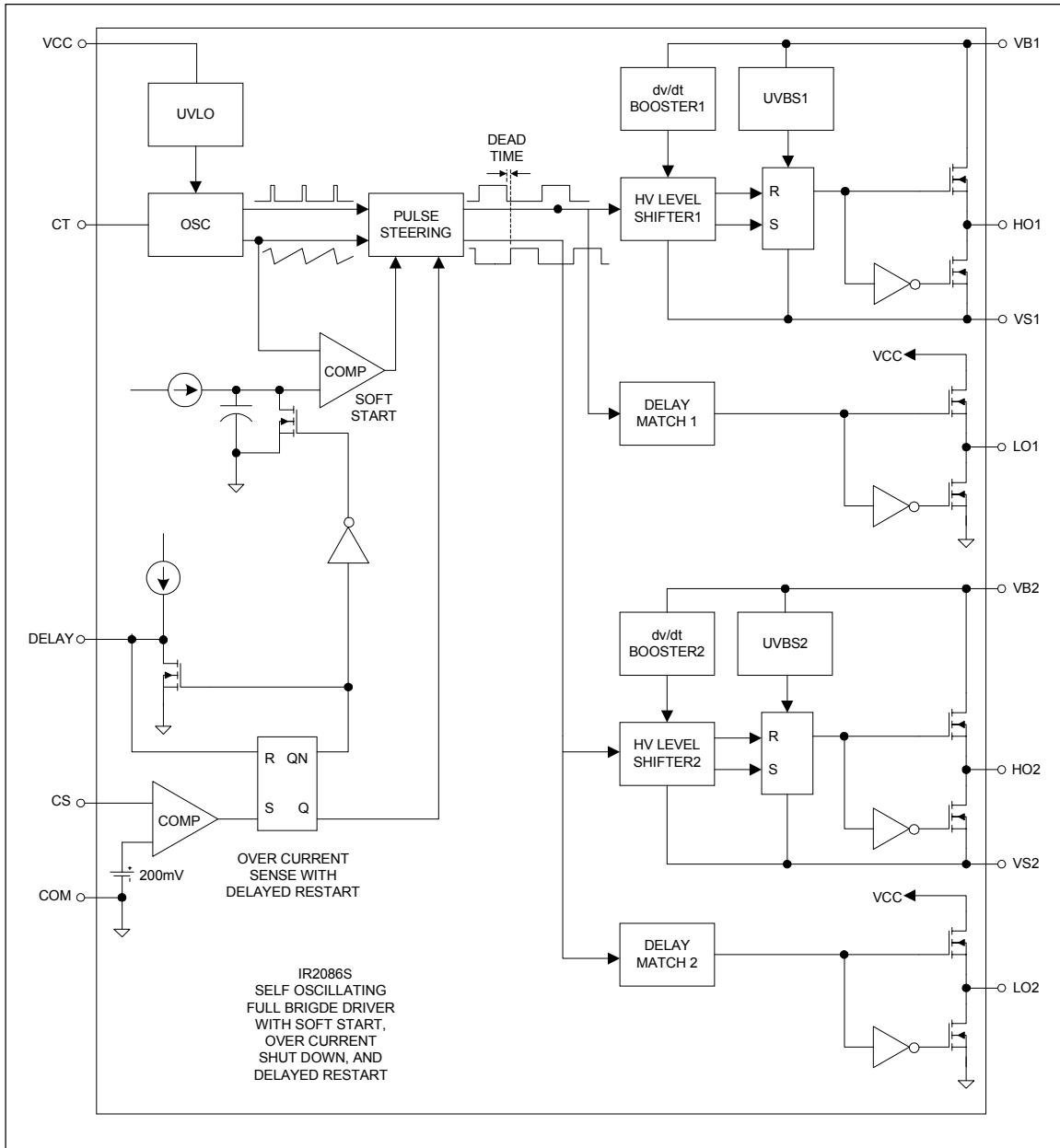

Lead Definitions

Lead Assignments

| Symbol | Description | | |
|--------|----------------------------|--|--|
| VCC | Supply | | |
| COM1,2 | Supply return | | |
| VB1,2 | High side floating supply | | |
| VS1,2 | Floating supply return | | |
| HO1,2 | High side output | | |
| LO1,2 | Low side output | | |
| CT | Oscillator Input | | |
| CS | Current sense input | | |
| DELAY | Over current restart delay | | |

| | | | |
|---|-------|------|----|
| 1 | n/c | VB1 | 16 |
| 2 | CS | HO1 | 15 |
| 3 | DELAY | VS1 | 14 |
| 4 | CT | COM2 | 13 |
| 5 | COM1 | LO2 | 12 |
| 6 | LO1 | VS2 | 11 |
| 7 | VCC | HO2 | 10 |
| 8 | n/c | VB2 | 9 |

Detailed Pin Description

CS: The input pin to the overcurrent comparator. Exceeding the overcurrent threshold value specified in “Static Electrical Parameters” Section will terminate output pulses. A new soft start cycle will commence after the expiration of the programmed delay time at DELAY pin.

DELAY: Delay programming pin for restart after overcurrent condition. A capacitor connected to this pin will determine the delay from the over current trip to the beginning of a new soft start cycle. The delay time ranges from 10us to 1s, and is set according to:

$$t_d \approx \frac{C_d V_{cc}}{2\mu A} + 10\mu s$$

CT: The oscillator-programming pin. Only two components are required to program the internal oscillator frequency: a resistor connected between the Vcc pin and the CT pin, and a capacitor connected from the CT pin to GND. The approximate oscillator frequency is determined by the following simple formula:

$$f_{osc} = 1 / (2 \cdot R_T \cdot C_T)$$

Where frequency is in Hertz (Hz), R_T resistance in Ohms (Ω) and C_T capacitance in Farads (F). The recommended range of timing resistors is between 10k Ω and 100k Ω and range of time capacitances is between 47pF and 470pF. The timing resistors less than 10k Ω should be avoided.

The value of the timing capacitor determines the amount of dead time between the two output drivers: lower the CT, shorter the dead time and vice versa. It is not recommended to use a timing capacitor below 47pF. For best performance, keep the time components as close as possible to the IR2086S. Separated ground and Vdd traces to the timing components are encouraged.

Detailed Pin Description continued

COM1, COM2: Signal ground and power ground for all functions. Due to high current and high frequency operation, a low impedance circuit board ground plane is highly recommended.

HO1, HO2, LO1, LO2: High side and low side gate drive pins. The high and low side drivers can directly drive the gate of a power MOSFET. The drivers are capable of 1A peak source and sink currents. It is recommended that the high and low drive pins be very close to the gates of the high side and low side MOSFETs to prevent any delay and distortion of the drive signals.

Vb1, Vb2: High side power input connection. The high side supplies are derived from bootstrap circuits using low-leakage Schottky diodes and ceramic capacitors. To prevent noise, the Schottky diodes and bypass capacitors should be very close to the IR2086S.

Vs1, Vs2: The high side power return connection. Vs should be connected directly to the source terminal of high side MOSFET with a trace as short as possible.

Vcc: The IC bias input connection for the device. Although the quiescent Vcc current is very low, total supply current will be higher, depending on the gate charge of the MOSFETs connected to the HO and LO pins, and the programmed oscillator frequency, Total Vcc current is the sum of quiescent Vcc current and the average current at HO and LO. Knowing the operating frequency and the MOSFET gate charge (Qg) at selected Vcc voltage, the average current to drive four power MOSFETs in full-bridge configuration can be calculated from:

$$I_{ave} = 4 \times Q_g \times f_{osc}$$

(Note that fosc is equal to the frequency per channel.)

To prevent noise problem, a bypass ceramic capacitor connected to Vcc and COM1 / COM2 should be placed as close as possible to the IR2086S.

IR2086S has an under voltage lookout feature for the IC bias supply, Vcc. The minimum voltage required on Vcc to make sure that IC will work within specifications must be higher than 8.5V (9.5V minimum Vcc is recommended to prevent asymmetrical gates signals on HO and LO pins that are expected when Vcc is between 7.5V and 8.5V).

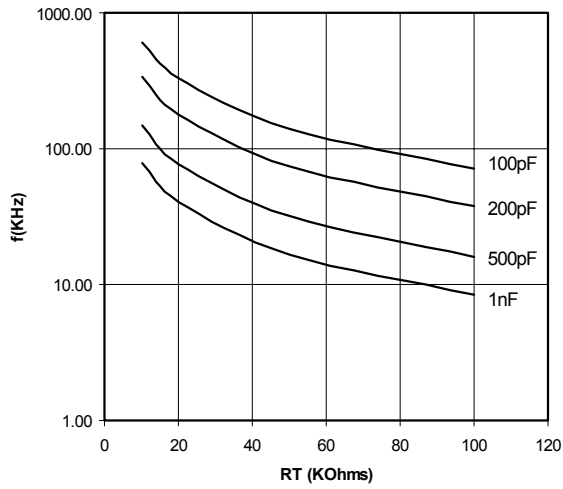

Fig. 1 Output Frequency (-25°C to 125°C)

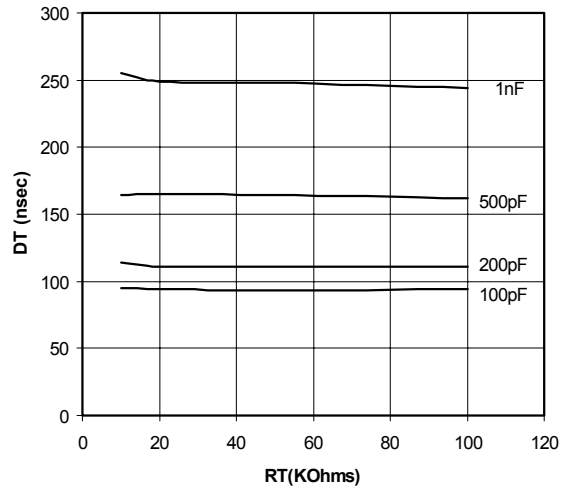

Fig. 2 Dead Time (@27°C)

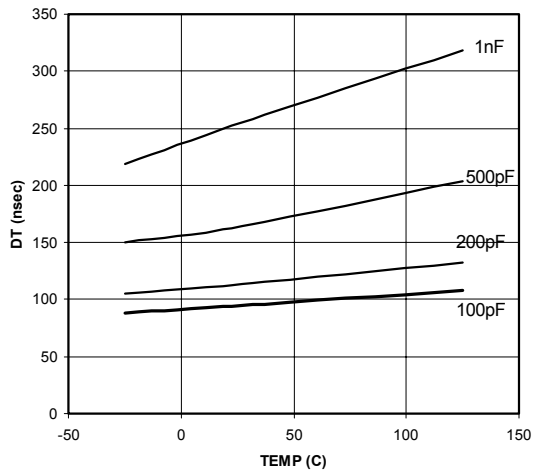

Fig. 3 Dead Time vs Temp

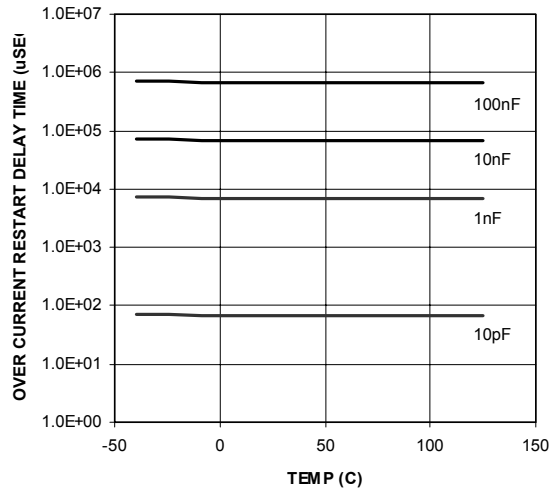
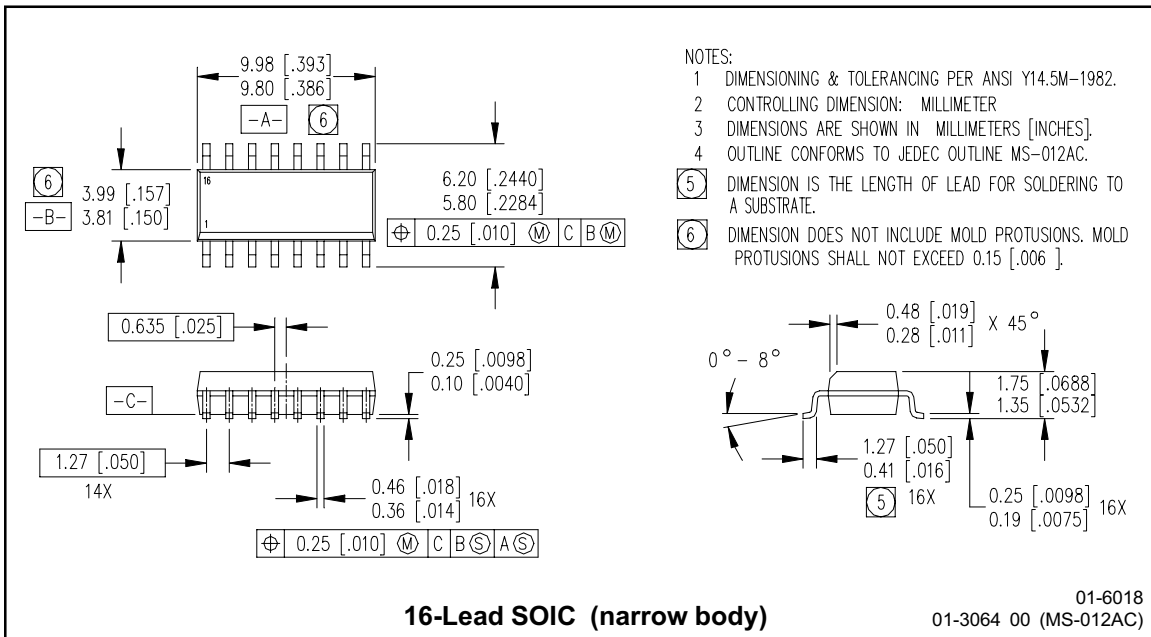
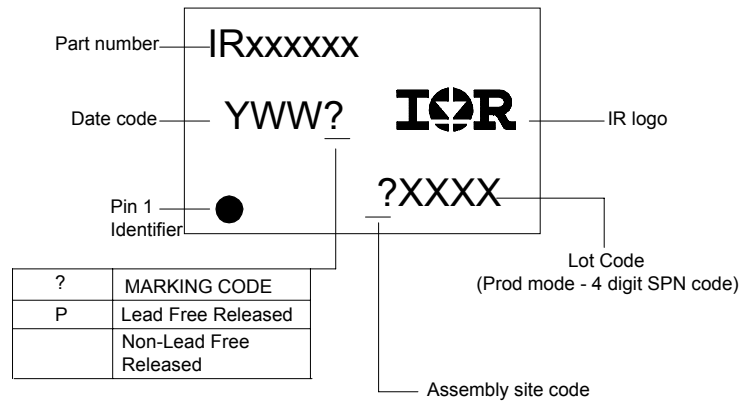

Fig. 4 Over Current Restart Delay Time vs Temp (Vcc = 15V)

Case outlines



LEADFREE PART MARKING INFORMATION



ORDERING INFORMATION

| PKG DESIG | PART NUMBER | LEADFREE PART NUMBER | PIN COUNT | PARTS PER TUBE | PARTS PER REEL |
|-----------|-------------|----------------------|-----------|----------------|----------------|
| S | IR2086S | IR2086SPbF | 16 | 45 | ----- |
| S | IR2086STR | IR2086STRPbF | 16 | ----- | 2500 |

X-ON Electronics

Largest Supplier of Electrical and Electronic Components

Click to view similar products for [Gate Drivers](#) category:

Click to view products by [Infineon](#) manufacturer:

Other Similar products are found below :

[00053P0231](#) [56956](#) [57.404.7355.5](#) [LT4936](#) [57.904.0755.0](#) [5882900001](#) [00600P0005](#) [00-9050-LRPP](#) [00-9090-RDPP](#) [5951900000](#) [01-1003W-10/32-15](#) [0131700000](#) [00-2240](#) [LTP70N06](#) [LVP640](#) [5J0-1000LG-SIL](#) [LY1D-2-5S-AC120](#) [LY2-US-AC240](#) [LY3-UA-DC24](#) [00576P0020](#) [00600P0010](#) [LZN4-UA-DC12](#) [LZNQ2M-US-DC5](#) [LZNQ2-US-DC12](#) [LZP40N10](#) [00-8196-RDPP](#) [00-8274-RDPP](#) [00-8275-RDNP](#) [00-8722-RDPP](#) [00-8728-WHPP](#) [00-8869-RDPP](#) [00-9051-RDPP](#) [00-9091-LRPP](#) [00-9291-RDPP](#) [0207100000](#) [0207400000](#) [01312](#) [0134220000](#) [60713816](#) [M15730061](#) [61161-90](#) [61278-0020](#) [6131-204-23149P](#) [6131-205-17149P](#) [6131-209-15149P](#) [6131-218-17149P](#) [6131-220-21149P](#) [6131-260-2358P](#) [6131-265-11149P](#) [CS1HCPU63](#)