

# IRG4IBC10UDPbF

UltraFast Co-Pack IGBT

INSULATED GATE BIPOLAR TRANSISTOR WITH  
ULTRAFast SOFT RECOVERY DIODE

## Features

- UltraFast: Optimized for high operating up to 80 kHz in hard switching, >200 kHz in resonant mode
- Generation 4 IGBT design provides tighter parameter distribution and higher efficiency than previous generation
- IGBT co-packaged with HEXFRED® ultrafast, ultra-soft recovery anti-parallel diodes for use in bridge configurations
- Industry standard TO-220 Full-Pak
- Lead-Free

## Benefits

- Generation 4 IGBTs offer highest efficiencies available
- IGBTs optimized for specific application conditions
- HEXFRED® diodes optimized for performance with IGBTs  
Minimized recovery characteristics require less/no snubbing

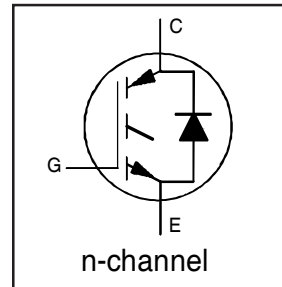

$$V_{CES} = 600V$$

$$V_{CE(on)} \text{ typ.} = 2.15V$$

$$@V_{GE}=15V, I_C=5.0A$$

$$t_f \text{ (typ.)} = 140ns$$

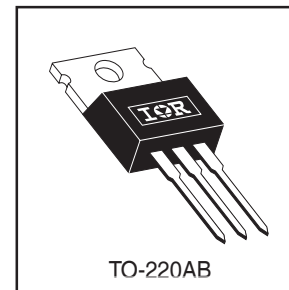

## Absolute Maximum Ratings

	Parameter	Max.	Units
$V_{CES}$	Collector-to-Emitter Breakdown Voltage	600	V
$I_C @ T_C = 25^\circ C$	Continuous Collector Current, $V_{GE} @ 15V$	6.8	A
$I_C @ T_C = 100^\circ C$	Continuous Collector, $V_{GE} @ 15V$	3.9	
$I_{CM}$	Pulsed Collector Current ①	27	
$I_{LM}$	Clamped Inductive Load Current ②	27	
$I_F @ T_C = 100^\circ C$	Diode Continuous Forward Current ②	3.9	
$I_{FM}$	Diode Maximum Forward Current	27	
$V_{ISOL}$	rms Isolated Voltage, Terminal to case, $t=1min$	2500	V
$V_{GE}$	Gate-to-Emitter Voltage	$\pm 20$	
$P_D @ T_C = 25^\circ C$	Power Dissipation	25	W
$P_D @ T_C = 100^\circ C$	Power Dissipation	10	
$T_J$ $T_{STG}$	Operating Junction and Storage Temperature Range	-55 to + 150	°C
	Soldering Temperature for 10 seconds	300 (0.063 in.) (1.6mm from case)	
	Mounting Torque, 6-32 or M3 Screw	10lb·in (1.1N·m)	

## Thermal Resistance

	Parameter	Typ.	Max.	Units
$R_{\theta JC}$	Junction-to-Case - IGBT	—	5.0	°C/W
$R_{\theta JC}$	Junction-to-Case - Diode	—	9.0	
$R_{\theta JA}$	Junction-to-Ambient, typical socket mount	—	65	
Wt	Weight	2.1 (0.075)	—	g (oz)

# IRG4IB10UDPbF

## Electrical Characteristics @ $T_J = 25^\circ\text{C}$ (unless otherwise specified)

	Parameter	Min.	Typ.	Max.	Units	Conditions
$V_{(BR)CES}$	Collector-to-Emitter Breakdown Voltage <sup>③</sup>	600	—	—	V	$V_{GE} = 0V, I_{CE} = 250\mu A$
$\Delta V_{(BR)CES}/\Delta T_J$	Breakdown Voltage Temp. Coefficient	—	0.54	—	V/ $^\circ\text{C}$	$V_{GE} = 0V, I_{CE} = 1.0mA$
$V_{CE(on)}$	Collector-to-Emitter Saturation Voltage	—	2.15	2.6	V	$V_{GE} = 15V, I_{CE} = 5.0A$
		—	2.61	—		$V_{GE} = 15V, I_{CE} = 8.5A$
		—	2.30	—		$V_{GE} = 15V, I_{CE} = 5.0A, T_J = 150^\circ\text{C}$
$V_{GE(th)}$	Gate Threshold Voltage	3.0	—	6.0	V	$V_{CE} = V_{GE}, I_{CE} = 250\mu A$
$\Delta V_{GE(th)}/\Delta T_J$	Gate Threshold Voltage Coefficient	—	-8.7	—	mV/ $^\circ\text{C}$	
$g_{fe}$	Forward Transconductance <sup>⑤</sup>	2.8	4.2	—	S	$V_{CE} = 100V, I_{CE} = 5.0A$
$I_{CES}$	Collector-to-Emitter Leakage Current	—	—	250	$\mu A$	$V_{CE} = 600V, V_{GE} = 0V$
		—	—	1000		$V_{CE} = 600V, V_{GE} = 0V, T_J = 150^\circ\text{C}$
$V_{FM}$	Diode Forward Voltage Drop	—	1.5	1.8	V	$I_C = 4.0A$
		—	1.4	1.7		$I_C = 4.0A, T_J = 125^\circ\text{C}$
$I_{GES}$	Gate-to-Emitter Forward Leakage	—	—	100	nA	$V_{GE} = 20V$
	Gate-to-Emitter Reverse Leakage	—	—	-100		$V_{GE} = -20V$

## Switching Characteristics @ $T_J = 25^\circ\text{C}$ (unless otherwise specified)

$Q_g$	Total Gate Charge (turn-on)	—	15	22	nC	$V_{CE} = 400V$
$Q_{ge}$	Gate-to-Emitter Charge (turn-on)	—	2.6	4.0		$I_C = 5.0A$
$Q_{gc}$	Gate-to-Collector Charge	—	5.8	8.7		$V_{GE} = 15V, \text{See Fig. 8}$
$t_{d(on)}$	Turn-On delay time	—	40	—	ns	$I_C = 5.0A, V_{CC} = 480V$ $V_{GE} = 15V, R_G = 100\Omega$ $T_J = 25^\circ\text{C}$
$t_r$	Rise time	—	16	—		
$t_{d(off)}$	Turn-Off delay time	—	87	130		
$t_f$	Fall time	—	140	210		
$E_{(on)}$	Turn-On Switching Loss	—	0.14	—	mJ	Energy losses include "tail" and diode reverse recovery. See Fig. 9, 10, 18
$E_{(off)}$	Turn-Off Switching Loss	—	0.12	—		
$E_{ts}$	Total Switching Loss	—	0.26	0.33		
$t_{d(on)}$	Turn-On delay time	—	38	—	ns	$I_C = 5.0A, V_{CC} = 480V \text{ See Fig. 11, 18}$ $V_{GE} = 15V, R_G = 100\Omega$ $T_J = 150^\circ\text{C}$ Energy losses include "tail" and diode reverse recovery.
$t_r$	Rise time	—	18	—		
$t_{d(off)}$	Turn-Off delay time	—	95	—		
$t_f$	Fall time	—	250	—		
$E_{ts}$	Total Switching Loss	—	0.45	—	mJ	
$L_E$	Internal Emitter Inductance	—	7.5	—	nH	Measured 5mm from package
$C_{ies}$	Input Capacitance	—	270	—	pF	$V_{GE} = 0V$
$C_{oes}$	Output Capacitance	—	21	—		$V_{CE} = 30V$
$C_{res}$	Reverse Transfer Capacitance	—	3.5	—		$f = 1.0MHz, \text{See Fig. 7}$
$t_{rr}$	Diode Reverse Recovery Time	—	28	42	ns	$T_J = 25^\circ\text{C}, \text{See Fig. 14}$
		—	38	57		$T_J = 125^\circ\text{C}$
$I_{rr}$	Diode Peak Reverse Recovery Current	—	2.9	5.2	A	$T_J = 25^\circ\text{C}, \text{See Fig. 15}$
		—	3.7	6.7		$T_J = 125^\circ\text{C}$
$Q_{rr}$	Diode Reverse Recovery Charge	—	40	60	nC	$T_J = 25^\circ\text{C}, \text{See Fig. 16}$
		—	70	105		$T_J = 125^\circ\text{C}$
$di_{(rec)M}/dt$	Diode Peak Rate of Fall of Recovery During $t_b$	—	280	—	A/ $\mu s$	$T_J = 25^\circ\text{C}, \text{See Fig. 17}$
		—	235	—		$T_J = 125^\circ\text{C}$

Details of note ① through ④ are on the last page

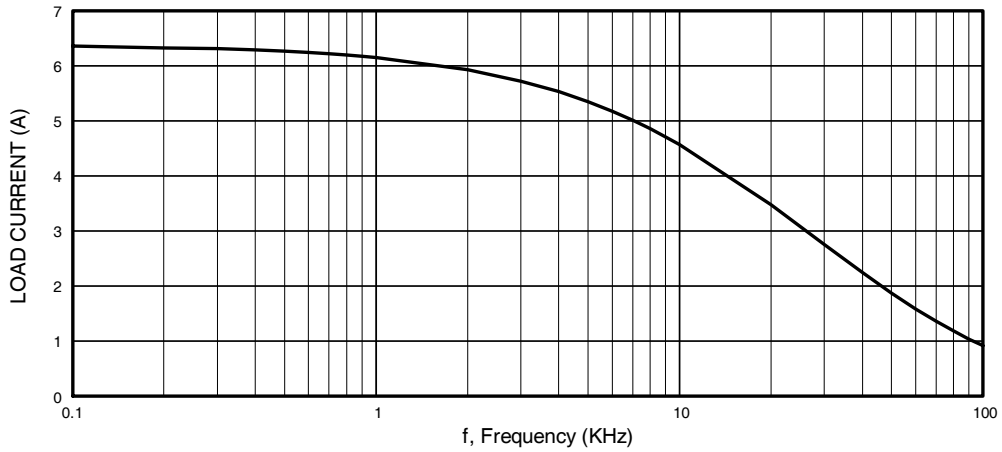

**Fig. 1 - Typical Load Current vs. Frequency**  
 (For square wave,  $I = I_{RMS}$  of fundamental; for triangular wave,  $I = I_{PK}$ )

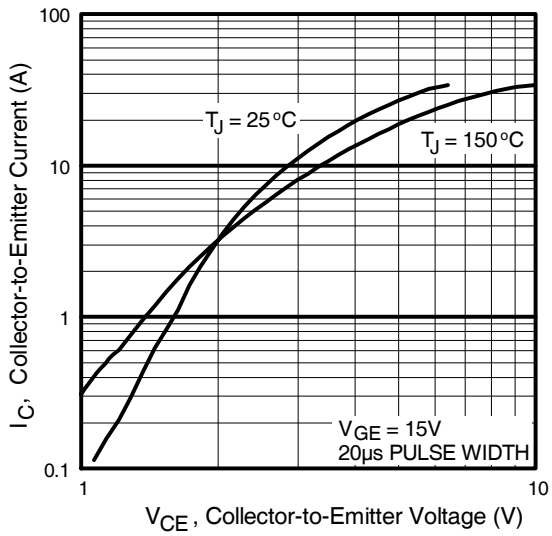

**Fig. 2 - Typical Output Characteristics**

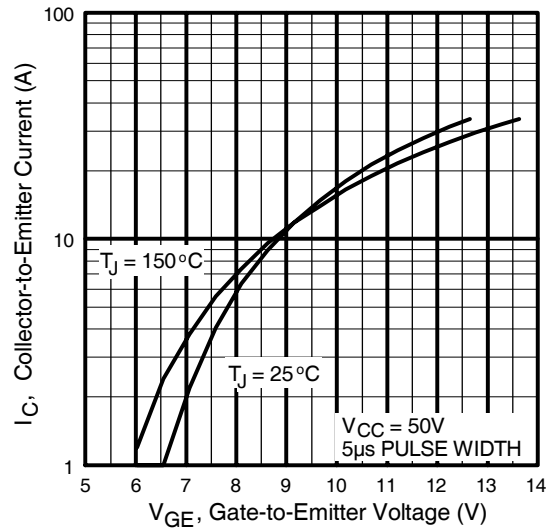

**Fig. 3 - Typical Transfer Characteristics**

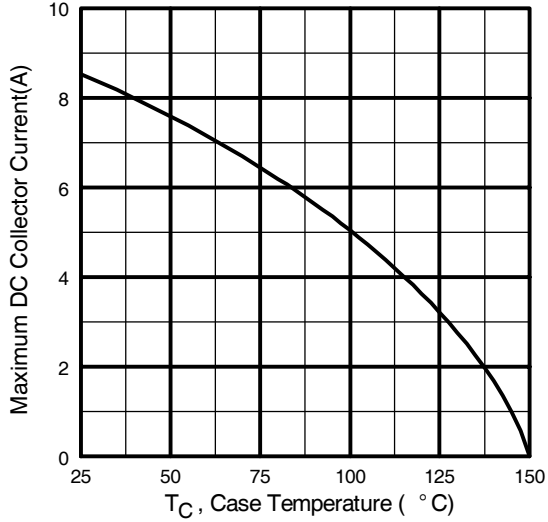

**Fig. 4** - Maximum Collector Current vs. Case Temperature

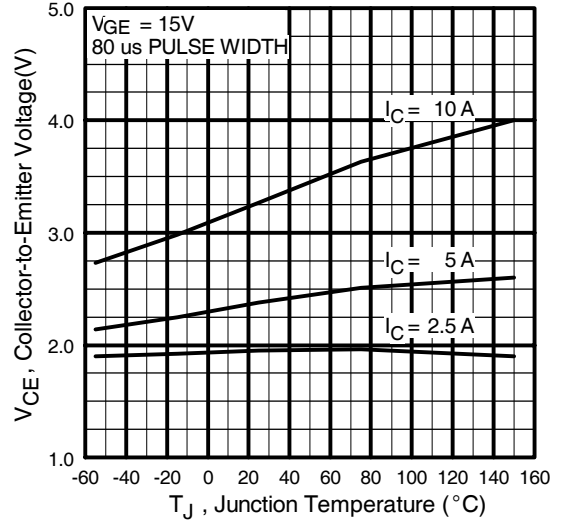

**Fig. 5** - Collector-to-Emitter Voltage vs. Junction Temperature

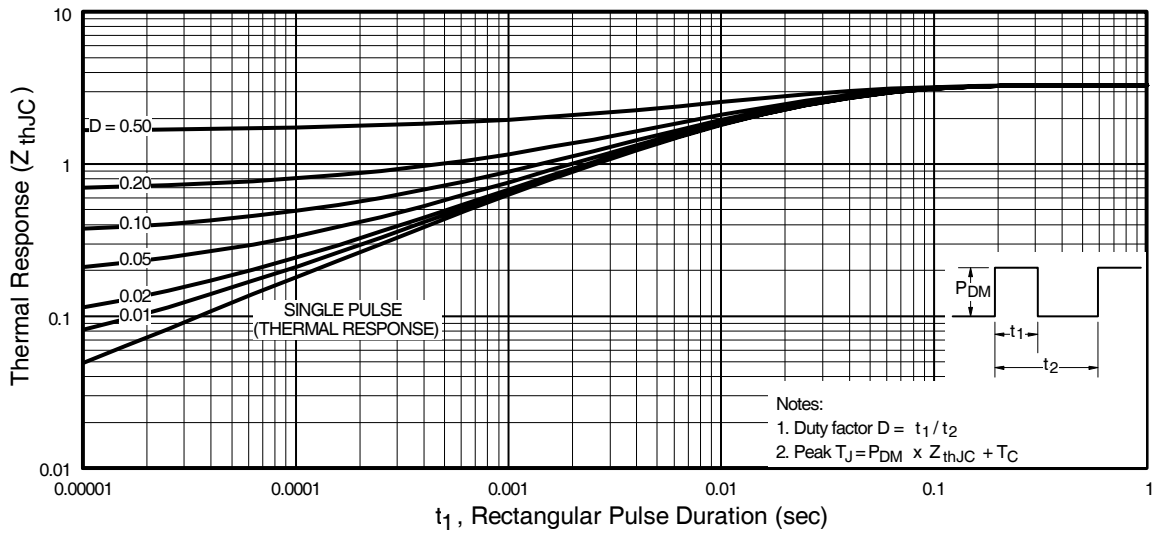

**Fig. 6** - Maximum Effective Transient Thermal Impedance, Junction-to-Case

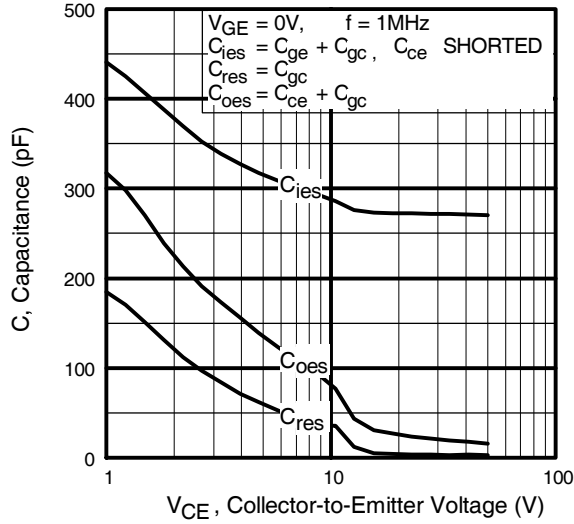

**Fig. 7** - Typical Capacitance vs. Collector-to-Emitter Voltage

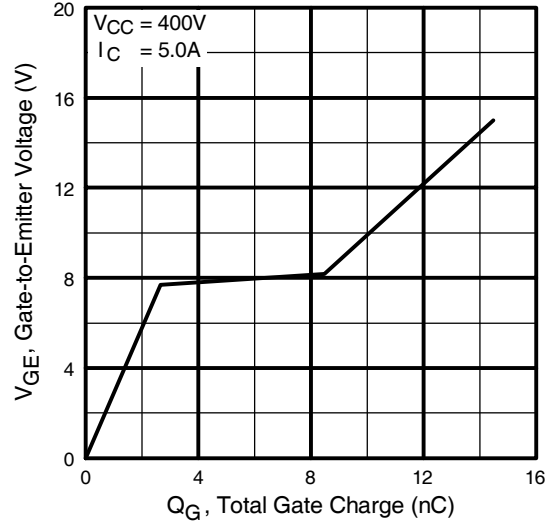

**Fig. 8** - Typical Gate Charge vs. Gate-to-Emitter Voltage

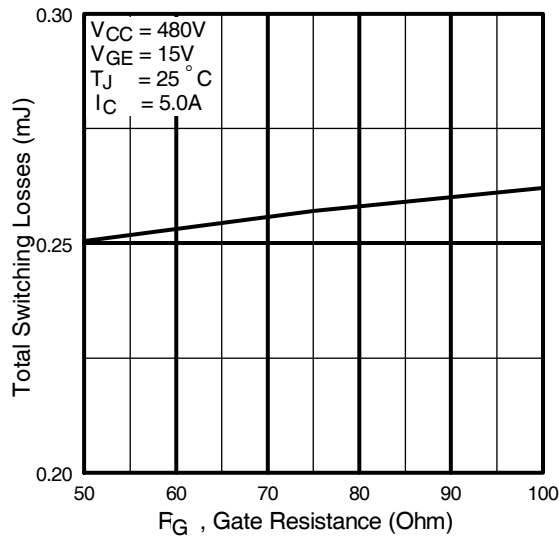

**Fig. 9** - Typical Switching Losses vs. Gate Resistance

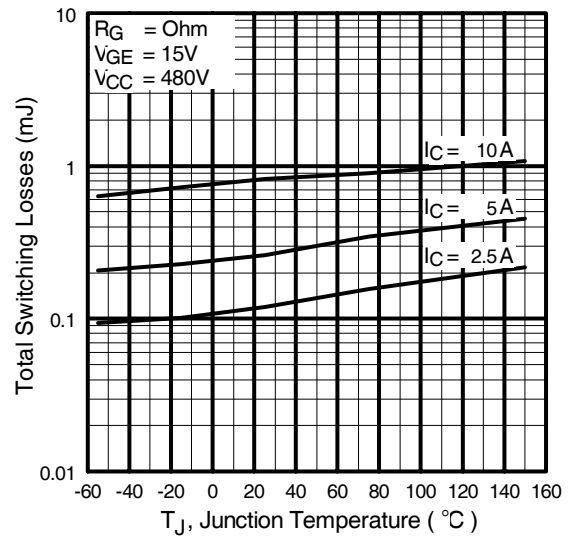

**Fig. 10** - Typical Switching Losses vs. Junction Temperature

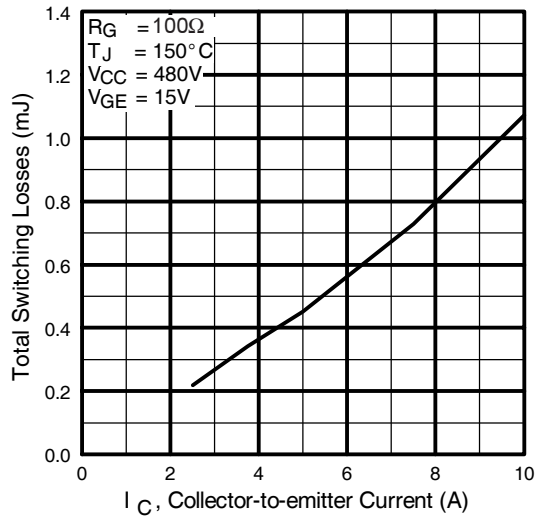

**Fig. 11** - Typical Switching Losses vs. Collector-to-emitter Current

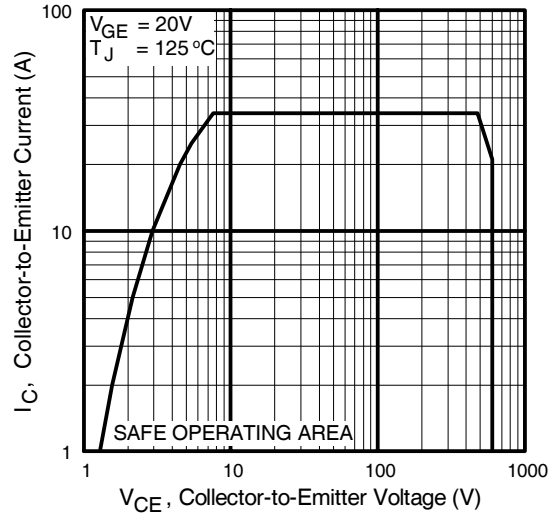

**Fig. 12** - Turn-Off SOA

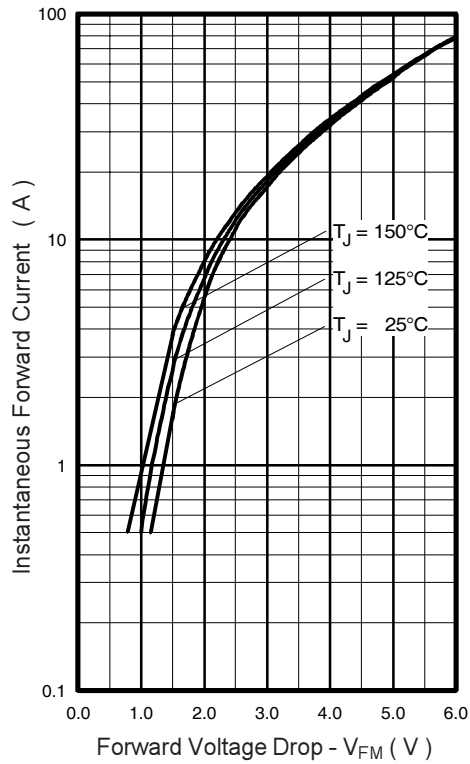

**Fig. 13** - Maximum Forward Voltage Drop vs. Instantaneous Forward Current

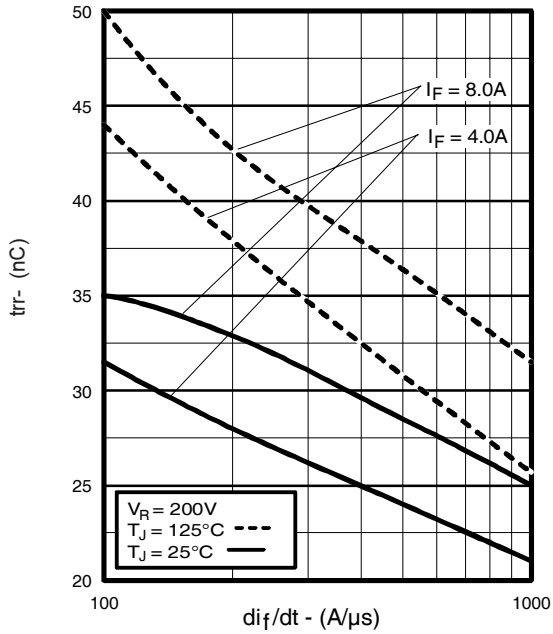

Fig. 14 - Typical Reverse Recovery vs.  $di_f/dt$

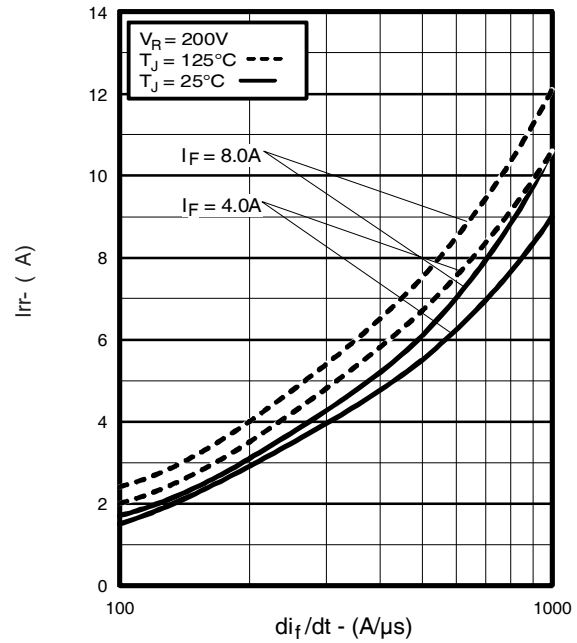

Fig. 15 - Typical Recovery Current vs.  $di_f/dt$

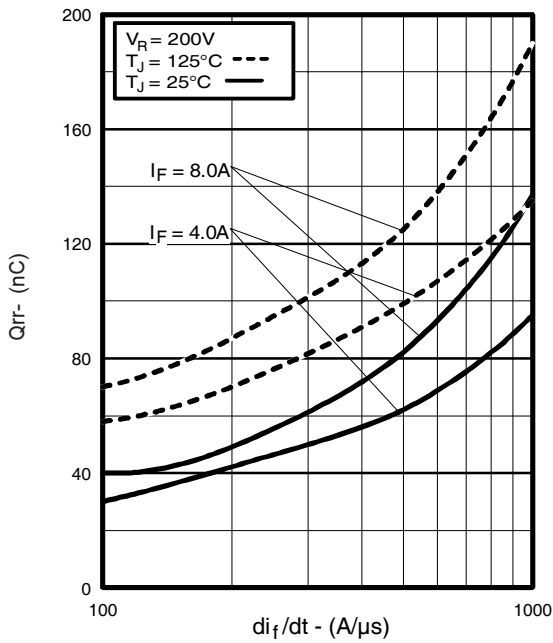

Fig. 16 - Typical Stored Charge vs.  $di_f/dt$

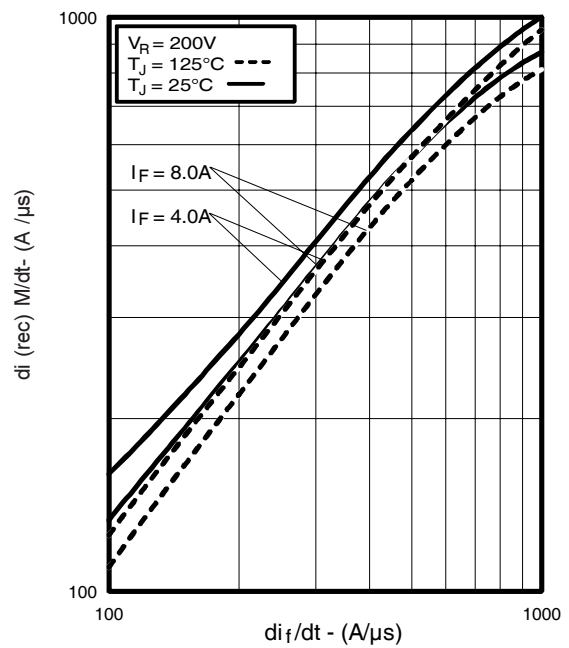
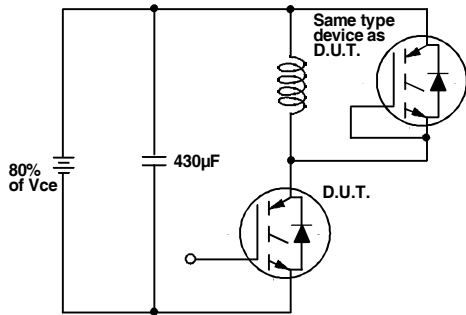
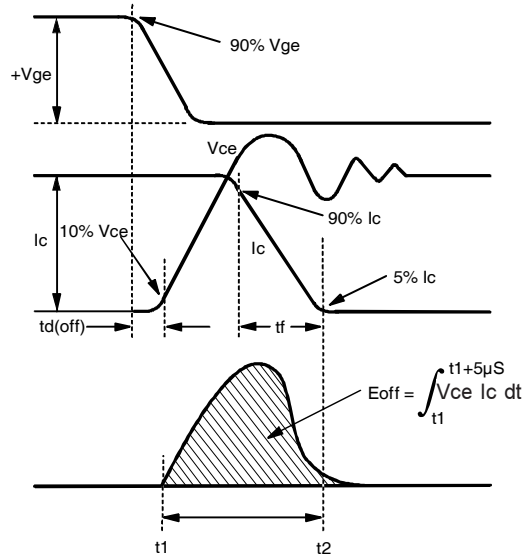

Fig. 17 - Typical  $di_{(rec)M}/dt$  vs.  $di_f/dt$



**Fig. 18a** - Test Circuit for Measurement of  $I_{LM}$ ,  $E_{on}$ ,  $E_{off}(\text{diode})$ ,  $t_{rr}$ ,  $Q_{rr}$ ,  $I_{rr}$ ,  $t_{d(on)}$ ,  $t_r$ ,  $t_{d(off)}$ ,  $t_f$



**Fig. 18b** - Test Waveforms for Circuit of Fig. 18a, Defining  $E_{off}$ ,  $t_{d(off)}$ ,  $t_f$

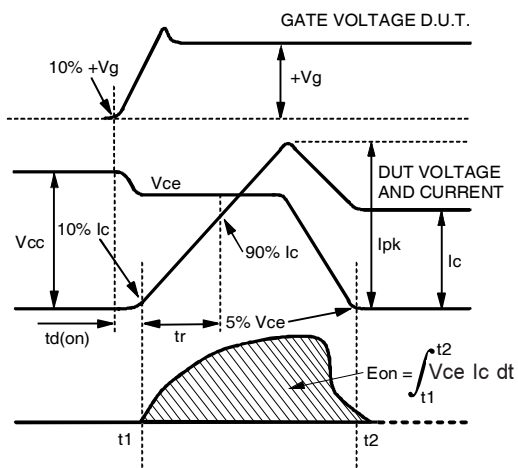

**Fig. 18c** - Test Waveforms for Circuit of Fig. 18a, Defining  $E_{on}$ ,  $t_{d(on)}$ ,  $t_r$

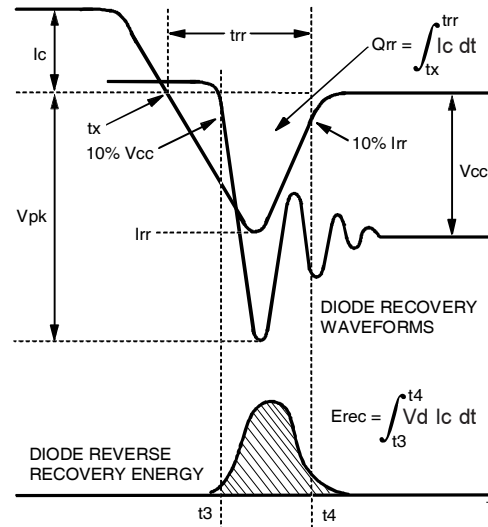

**Fig. 18d** - Test Waveforms for Circuit of Fig. 18a, Defining  $E_{rec}$ ,  $t_{rr}$ ,  $Q_{rr}$ ,  $I_{rr}$



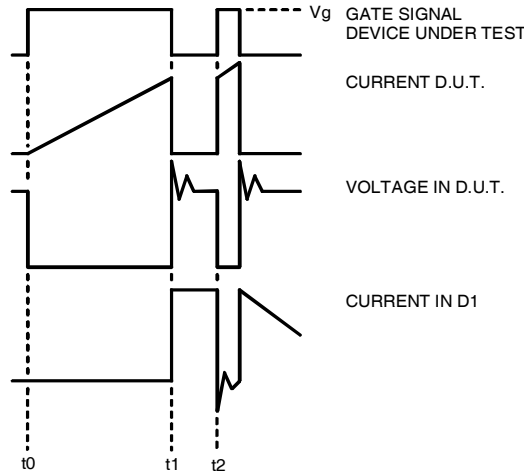

Figure 18e. Macro Waveforms for Figure 18a's Test Circuit

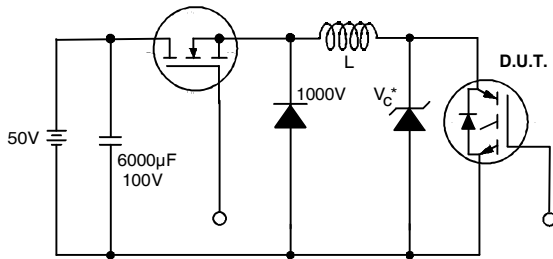

Figure 19. Clamped Inductive Load Test Circuit

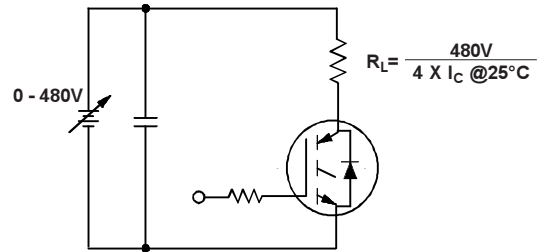
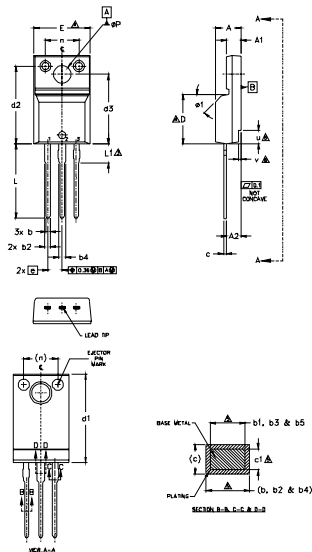

Figure 20. Pulsed Collector Current Test Circuit

# IRG4IB10UDPbF

## TO-220AB Full-Pak Package Outline

Dimensions are shown in millimeters (inches)



SYMBOL	DIMENSIONS				NOTES
	MILLIMETERS		INCHES		
	MIN.	MAX.	MIN.	MAX.	
A	4.57	4.83	.180	.190	1.0 DIMENSIONAL AND TOLERANCING AS PER ASME Y14.5 M-1994
A1	2.57	2.83	.101	.111	
A2	2.51	2.93	.099	.115	2.0 DIMENSIONS ARE SHOWN IN MILLIMETERS [INCHES]
b	0.61	0.94	.024	.037	3.0 LEAD DIMENSION AND FINISH UNCONTROLLED IN L1
b1	0.61	0.89	.024	.035	4.0 DIMENSION D & E DO NOT INCLUDE MOLD FLASH. MOLD FLASH SHALL NOT EXCEED .005" (0.127) PER SIDE. THESE DIMENSIONS ARE MEASURED AT THE OUTER MOST EXTREMES OF THE PLASTIC BODY.
b2	0.76	1.27	.030	.050	5.0 DIMENSION b1, b3, b5 & c1 APPLY TO BASE METAL ONLY
b3	0.76	1.22	.030	.048	6.0 STEP OPTIONAL ON PLASTIC BODY DEFINED BY DIMENSIONS u & v.
b4	1.02	1.52	.040	.060	7.0 CONTROLLING DIMENSION - INCHES.
b5	1.02	1.47	.040	.058	
c	0.33	0.63	.013	.025	
c1	0.33	0.58	.013	.023	
D	8.66	9.80	.341	.386	
d1	15.80	16.13	.622	.635	
d2	13.97	14.22	.550	.560	
d3	12.30	12.93	.484	.509	
E	9.63	10.76	.379	.423	
e	2.54	BSC	.100	BSC	
L	13.20	13.72	.520	.540	
L1	3.37	3.67	.122	.145	
n	6.05	6.60	.238	.260	
nP	3.05	3.45	.120	.136	
u	2.40	2.50	.094	.098	
v	0.40	0.50	.016	.020	
w	-	45°	-	45°	

NOTES:  
1.0 DIMENSIONAL AND TOLERANCING AS PER ASME Y14.5 M-1994  
2.0 DIMENSIONS ARE SHOWN IN MILLIMETERS [INCHES]  
3.0 LEAD DIMENSION AND FINISH UNCONTROLLED IN L1  
4.0 DIMENSION D & E DO NOT INCLUDE MOLD FLASH. MOLD FLASH SHALL NOT EXCEED .005" (0.127) PER SIDE. THESE DIMENSIONS ARE MEASURED AT THE OUTER MOST EXTREMES OF THE PLASTIC BODY.  
5.0 DIMENSION b1, b3, b5 & c1 APPLY TO BASE METAL ONLY  
6.0 STEP OPTIONAL ON PLASTIC BODY DEFINED BY DIMENSIONS u & v.  
7.0 CONTROLLING DIMENSION - INCHES.

**LEAD ASSIGNMENTS**

- 1- GATE
- 2- DRAIN
- 3- SOURCE

**USE IN CAPABLE**

- 1- GATE
- 2- COLLECTOR
- 3- EMITTER

## TO-220AB Full-Pak Part Marking Information

EXAMPLE: THIS IS AN IRF1840G  
WITH ASSEMBLY  
LOT CODE 3432  
ASSEMBLED ON WW 24, 2001  
IN THE ASSEMBLY LINE 'K'

Note: 'P' in assembly line position  
indicates 'Lead-Free'

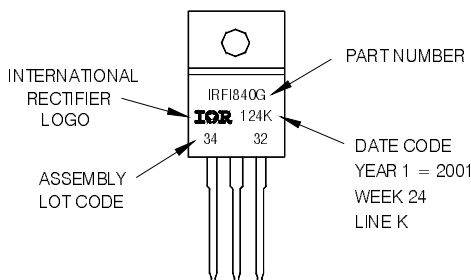

TO-220AB Full-Pak package is not recommended for Surface Mount Application.

**Notes:**

- ① Repetitive rating;  $V_{GE} = 20V$ , pulse width limited by max. junction temperature (See fig. 20).
- ②  $V_{CC} = 80\%(V_{CES})$ ,  $V_{GE} = 20V$ ,  $L = 10\mu H$ ,  $R_G = 100\Omega$ , (See fig. 19).
- ③ Pulse width  $\leq 80\mu s$ ; duty factor  $\leq 0.1\%$ .
- ④ Pulse width  $5.0\mu s$ , single shot.

Note: For the most current drawing please refer to IR website at <http://www.irf.com/package/>

Data and specifications subject to change without notice.

## X-ON Electronics

Largest Supplier of Electrical and Electronic Components

*Click to view similar products for [IGBT Transistors](#) category:*

*Click to view products by [Infineon](#) manufacturer:*

Other Similar products are found below :

[748152A](#) [APT20GT60BRDQ1G](#) [APT50GT60BRG](#) [NGTB10N60FG](#) [STGFW20V60DF](#) [APT30GP60BG](#) [APT45GR65B2DU30](#)  
[GT50JR22\(STA1ES\)](#) [TIG058E8-TL-H](#) [IGW40N120H3FKSA1](#) [VS-CPV364M4KPBF](#) [NGTB25N120FL2WAG](#) [NGTG40N120FL2WG](#)  
[RJH60F3DPQ-A0#T0](#) [APT40GR120B2SCD10](#) [APT15GT120BRG](#) [APT20GT60BRG](#) [NGTB75N65FL2WAG](#) [NGTG15N120FL2WG](#)  
[IXA30RG1200DHGLB](#) [IXA40RG1200DHGLB](#) [APT70GR65B2DU40](#) [NTE3320](#) [QP12W05S-37A](#) [IHF40N65R5SFKSA1](#) [APT70GR120J](#)  
[APT35GP120JDQ2](#) [IKZA40N65RH5XKSA1](#) [IKFW75N65ES5XKSA1](#) [IKFW50N65ES5XKSA1](#) [IKFW50N65EH5XKSA1](#)  
[IKFW40N65ES5XKSA1](#) [IKFW60N65ES5XKSA1](#) [IMBG120R090M1HXTMA1](#) [IMBG120R220M1HXTMA1](#) [XD15H120CX1](#)  
[XD25H120CX0](#) [XP15PJS120CL1B1](#) [IGW30N60H3FKSA1](#) [STGWA8M120DF3](#) [IGW08T120FKSA1](#) [IGW75N60H3FKSA1](#)  
[FGH60N60SMD\\_F085](#) [FGH75T65UPD](#) [STGWA15H120F2](#) [IKA10N60TXKSA1](#) [IHW20N120R5XKSA1](#) [RJH60D2DPP-M0#T2](#)  
[IKP20N60TXKSA1](#) [IHW20N65R5XKSA1](#)