

PFC + BALLAST CONTROL IC

Features

- PFC, ballast control and 600 V half-bridge driver in one IC
- Critical-conduction mode boost-type PFC
- Programmable half-bridge over-current protection
- Programmable preheat frequency
- Programmable deadtime
- Programmable preheat time
- Programmable run frequency
- RoHS compliant
- End-of-life window comparator pin
- Internal up/down current-sense fault counter
- DC bus undervoltage reset
- Lamp removal/auto-restart shutdown pin
- Internal bootstrap MOSFET
- Internal 15.6 V zener clamp diode on V_{CC}
- Micropower startup (250 μA)
- Latch immunity and ESD protection

Description

The IRS2166D is a fully integrated, fully protected 600 V ballast control IC designed to drive all types of fluorescent lamps. The IRS2166D is based on the popular IR2166 control IC with additional improvements to increase ballast performance. PFC circuitry operates in critical conduction mode and provides high PF, low THD, and DC bus regulation. The IRS2166D features include programmable preheat and run frequencies, programmable preheat time, and programmable end-of-life protection. Comprehensive protection features such as protection from failure of a lamp to strike, filament failures, end-of-life protection, DC bus undervoltage reset as well as an automatic restart function, have been included in the design.

System Features

- Improved V_{BUS} regulation voltage tolerance
- Increased SD pin shutdown voltage threshold hysteresis
- Changed EOL pin internal 2.0 V bias to a +/-10 μA OTA
- Internal bootstrap MOSFET

Packages

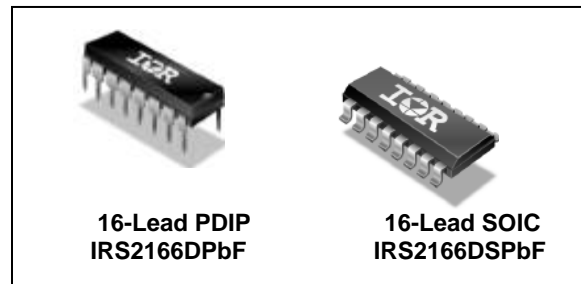

Application Diagram (Typical Only)

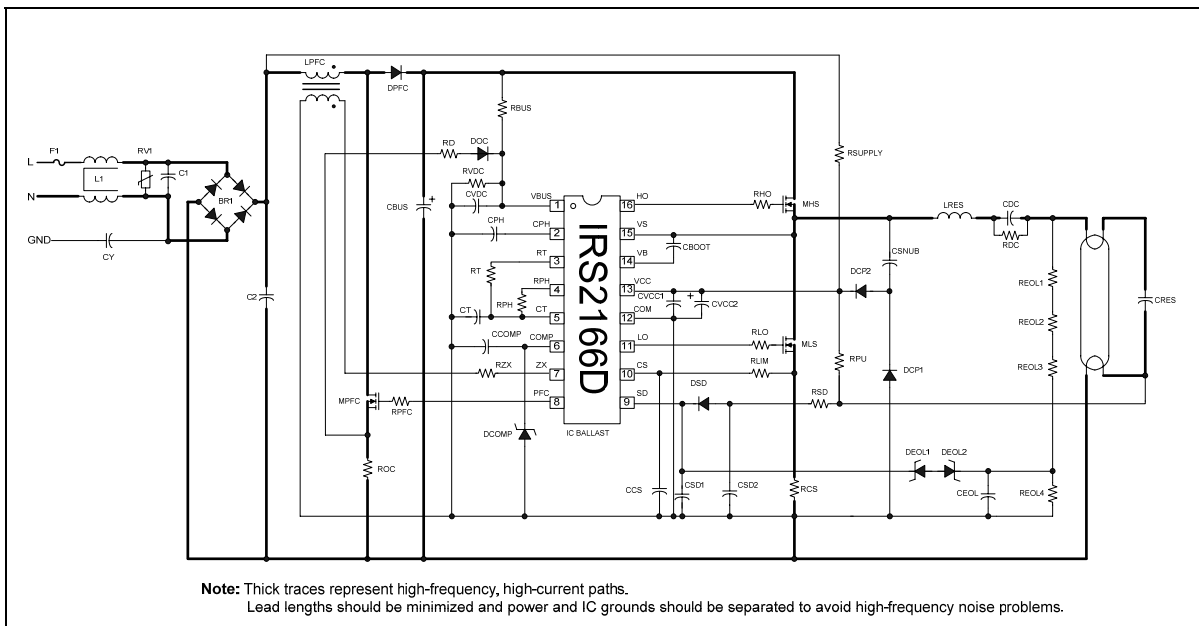

Absolute Maximum Ratings

Absolute maximum ratings indicate sustained limits beyond which damage to the device may occur. All voltage parameters are absolute voltages referenced to COM, all currents are defined positive into any lead. The thermal resistance and power dissipation ratings are measured under board mounted and still air conditions.

Symbol	Definition	Min.	Max.	Units	
V _B	High-side floating supply voltage	-0.3	625	V	
V _S	High-side floating supply offset voltage	V _B - 25	V _B + 0.3		
V _{HO}	High-side floating output voltage	V _S - 0.3	V _B + 0.3		
V _{LO}	Low-side output voltage	-0.3	V _{CC} + 0.3		
V _{PFC}	PFC gate driver output voltage	-0.3	V _{CC} + 0.3		
I _{O,MAX}	Maximum allowable output current (HO, LO, PFC) due to external power transistor miller effect	-500	500	mA	
V _{BUS}	VBUS pin voltage	-0.3	V _{CC} + 0.3	V	
V _{CPH}	CPH pin voltage	-0.3	V _{CC} + 0.3		
V _{RT}	RT pin voltage	-0.3	V _{CC} + 0.3		
V _{RPH}	RPH pin voltage	-0.3	V _{CC} + 0.3		
I _{RT}	RT pin current	-5	5	mA	
I _{RPH}	RPH pin current	-5	5		
V _{CT}	CT pin voltage	-0.3	V _{CC} + 0.3	V	
I _{COMP}	COMP pin current	-5	5	mA	
I _{ZX}	ZX pin current	-5	5		
I _{CC}	VCC pin current (see Note 1)	-25	25		
V _{SD/EOL}	SD/EOL pin voltage	-0.3	V _{CC} + 0.3	V	
I _{SD/EOL}	SD/EOL pin current	-5	5	mA	
V _{CS}	CS pin voltage	-0.3	V _{CC} + 0.3	V	
I _{CS}	CS pin current	-5	5	mA	
dV/dt	Allowable V _S offset voltage slew rate	-50	50	V/ns	
P _D	Package power dissipation @ T _A ≤ +25 °C PD = (T _{JMAX} - T _A) / R _{θJA}	(16-Pin DIP)	---	1.8	W
		(16-Pin SOIC)	---	1.4	
R _{θJA}	Thermal resistance, junction to ambient	(16-Pin DIP)	---	70	°C/W
		(16-Pin SOIC)	---	82	
T _J	Junction temperature	-55	150	°C	
T _S	Storage temperature	-55	150		
T _L	Lead temperature (soldering, 10 seconds)	---	300		

Note 1: This IC contains a zener clamp structure between the chip V_{CC} and COM which has a nominal breakdown voltage of 15.6 V. This supply pin should not be driven by a DC, low impedance power source greater than the V_{CLAMP} specified in the electrical characteristics section.

Recommended Operating Conditions

For proper operation the device should be used within the recommended conditions.

Symbol	Definition	Min.	Max.	Units
V _B -V _S	High side floating supply voltage	V _{BSUV+}	V _{CLAMP}	V
V _S	Steady state high-side floating supply offset voltage	-1	600	
V _{CC}	Supply voltage	V _{CCUV+}	V _{CLAMP}	
I _{CC}	V _{CC} supply current (see Note 2)	Note 2	20	mA
C _T	CT pin capacitance	220	---	pF
I _{SD/EOL}	SD/EOL pin current	-1	1	mA
I _{CS}	CS pin current			
I _{ZX}	ZX pin current			
T _J	Junction temperature	-25	125	°C

Note 2: Enough current should be supplied into the V_{CC} pin to keep the internal 15.6 V zener clamp diode on this pin regulating its voltage, V_{CLAMP}.

Electrical Characteristics

$V_{CC} = V_{BS} = V_{BIAS} = 14\text{ V} \pm 0.25\text{ V}$, $V_{CPH} = V_{SD/EOL} = V_{COMP} = V_{CS} = V_{BUS} = V_{ZX} = 0.0\text{ V}$, $R_T = R_{PH} = 39.2\text{ k}\Omega$, $C_{LO} = C_{HO} = C_{PFC} = 1000\text{ pF}$, $C_T = 470\text{ pF}$, $T_A = 25\text{ }^\circ\text{C}$ unless otherwise specified. See state diagram for MODE.

Symbol	Definition	Min	Typ	Max	Units	Test Conditions
Supply Characteristics						
V_{CCUV+}	V_{CC} supply undervoltage positive going threshold	11.5	12.5	13.5	V	V_{CC} rising from 0 V, CT = COM
V_{CCUV-}	V_{CC} supply undervoltage negative going threshold	9.5	10.5	11.5		V_{CC} falling from 14 V, CT = COM
V_{UVHYS}	V_{CC} supply undervoltage lockout hysteresis	1.5	2.0	3.0		CT = COM
I_{QCCUV}	UVLO mode V_{CC} quiescent current	---	250	500	μA	$V_{CC} = 8\text{ V}$, CT = COM
I_{QCC}	Quiescent V_{CC} supply current	---	4.3	5.1	mA	CT = COM
I_{QCCFLT}	Fault quiescent V_{CC} supply current	---	600	900	μA	MODE = FAULT
$I_{CC,RUN}$	V_{CC} current at RUN frequency	---	5.0	---	mA	MODE=RUN COMP=2 V, $t_{off,PFC}=2\text{ }\mu\text{s}$
V_{CLAMP}	V_{CC} zener clamp voltage	14.6	15.6	16.6	V	$I_{CC} = 10\text{ mA}$
Floating Supply Characteristics						
I_{QBS0}	Quiescent V_{BS} supply current	---	30	70	μA	$V_{HO} = V_S$
I_{QBS1}	Quiescent V_{BS} supply current	---	50	90		$V_{HO} = V_B$
V_{BSUV+}	V_{BS} supply undervoltage positive going threshold	8.0	9.0	10.0	V	V_{BS} rising from 0 V
V_{BSUV-}	V_{BS} supply undervoltage negative going threshold	7.0	8.0	9.0		V_{BS} falling from 14 V
I_{LKVS}	V_S offset supply leakage current	---	---	50	μA	$V_B = V_S = HO = 600\text{ V}$
PFC Error Amplifier Characteristics						
$I_{COMP,SOURCE}$	OTA error amplifier output current sourcing	20	30	40	μA	MODE = RUN $V_{VBUS} = 3.5\text{ V}$
$I_{COMP,SINK}$	OTA error amplifier output current sinking	-45	-35	-25		MODE = RUN $V_{VBUS} = 4.5\text{ V}$
V_{COMPOH}	OTA error amplifier output voltage swing (high state)	12.0	12.5	13.0	V	
V_{COMPOL}	OTA error amplifier output voltage swing (low state)	200	300	400	mV	
PFC Control Characteristics						
$V_{VBUSREG}$	V_{BUS} internal reference voltage (guaranteed by design)	3.9	4.0	4.1	V	$V_{COMP}=4.0\text{ V}$
$V_{VBUSOV+}$	V_{BUS} over-voltage comparator positive going threshold	4.1	4.3	4.5		
$V_{VBUSOV-}$	V_{BUS} over-voltage comparator negative going hysteresis	4.0	4.15	4.3		
V_{ZX}	ZX pin positive edge triggered threshold voltage	1.5	2.0	2.5		CT=COM
V_{ZXHYS}	ZX pin comparator hysteresis	100	300	500	mV	
$V_{ZXclamp}$	ZX pin clamp voltage (high state)	5.7	6.7	7.7	V	$I_{ZX} = 5\text{ mA}$, CT=COM
t_{WD}	PFC watch-dog pulse interval	150	400	500	μs	$V_{ZX} = 0\text{ V}$, $V_{COMP} = 2.0\text{ V}$ CT=COM

Electrical Characteristics (cont'd)

$V_{CC} = V_{BS} = V_{BIAS} = 14\text{ V} \pm 0.25\text{ V}$, $V_{CPH} = V_{SD/EOL} = V_{COMP} = V_{CS} = V_{BUS} = V_{ZX} = 0.0\text{ V}$, $R_T = R_{PH} = 39.2\text{ k}\Omega$, $C_{LO} = C_{HO} = C_{PFC} = 1000\text{ pF}$, $C_T = 470\text{ pF}$, $T_A = 25\text{ }^\circ\text{C}$ unless otherwise specified. See state diagram for MODE.

Symbol	Definition	Min	Typ	Max	Units	Test Conditions
PFC Protection Circuitry Characteristics						
$V_{VBUSUV-}$	V_{BUS} pin undervoltage reset threshold	2.7	3.0	3.3	V	CT=COM
Gate Driver Output Characteristics (HO, LO and PFC pins)						
V_{OL}	Low-level output voltage, LO, HO, PFC	---	COM	---	V	
V_{OH}	High-level output voltage, LO, HO, PFC	---	V_{CC}	---		
t_r	Turn-on rise time	---	120	220	ns	
t_f	Turn-off fall time	---	50	100		
I_{O+}	Source current	---	180	---	mA	
I_{O-}	Sink current	---	260	---		
Bootstrap FET Characteristics						
$V_{B,ON}$	V_B when the bootstrap FET is on	13.2	13.7	---	V	
$I_{B,CAP}$	V_B source current when FET is on	40	55	---	mA	$C_{BS} = 0.1\text{ }\mu\text{F}$
$I_{B,10V}$	V_B source current when FET is on	9	12	---		$V_B = 10\text{ V}$
Ballast Control Oscillator Characteristics						
f_{PH}	Preheat half-bridge oscillator frequency	73	76	81	kHz	MODE=PREHEAT
f_{RUN}	Run half-bridge oscillator frequency	40	43	46		MODE=RUN, CPH=13 V
D	Oscillator duty cycle	---	50	---	%	
$t_{d,LO}$	LO output deadtime	0.7	1.0	1.5	μs	
$t_{d,HO}$	HO output deadtime	0.7	1.0	1.5		
V_{CT+}	CT pin rising threshold voltage	7.8	8.4	9.0	V	
V_{CT-}	CT pin falling threshold voltage	4.1	4.6	5.1		
Ballast Control Preheat Characteristics						
V_{CPHEOP}	CPH pin end of preheat threshold voltage	---	10.8	---	V	CT=COM, $I_{RPH} < 2\text{ }\mu\text{A}$
V_{CPHRUN}	CPH pin run mode threshold voltage	---	12.0	---		$V_{BUS} = V_{CC}$, CT=COM, $V_{SDEOL} = 3.5\text{ V}$,
I_{RPHLK}	RPH pin leakage current	---	0.1	---	μA	MODE=RUN
I_{CPH}	CPH pin charging current	2.6	3.6	4.6		CPH=5 V
V_{CPHFLT}	CPH pin voltage in fault mode	---	0	---	V	MODE = FAULT
Ballast Control Protection Circuitry Characteristics						
V_{CSTH+}	CS pin over-current sense threshold	1.075	1.20	1.325	V	
n_{EVENTS}	CS pin fault counter number of events	70	100	140		MODE=PREHEAT, $V_{BUS} = 0\text{ V}$
V_{SDTH+}	SD pin rising non-latched shutdown threshold	4.5	5.0	5.5	V	CT=COM
V_{SDTH-}	SD pin falling reset threshold voltage	2.7	3.0	3.3		
$V_{SD,delay}$	Delay from V_{SDTH+} until LO goes low	---	450	---	ns	
$V_{EOLBIAS}$	EOL pin bias voltage	1.8	2.0	2.2	V	
$I_{EOL,src}$	EOL pin internal OTA source current	---	10	---	μA	SD = $V_{EOLBIAS} + 0.5\text{ V}$
$I_{EOL,snk}$	EOL pin internal OTA sink current	---	10	---		
V_{EOLTH+}	EOL pin rising latched shutdown threshold (active during RUN MODE)	2.7	3.0	3.3	V	MODE=RUN, CT=COM $V_{BUS} = 4.0\text{ V}$, CPH=13 V
V_{EOLTH-}	EOL pin falling latched shutdown threshold (active during RUN MODE)	0.9	1.0	1.1		
$V_{EOL,delay}$	Delay from V_{EOLTH+} until LO goes low	---	1	---	μs	MODE=RUN, CT=COM, CPH=13 V
V_{CTFLT}	CT pin fault mode voltage	---	0	---	V	MODE=FAULT
V_{CPHFLT}	CPH pin fault mode voltage	---	0	---		

Schematic Block Diagram

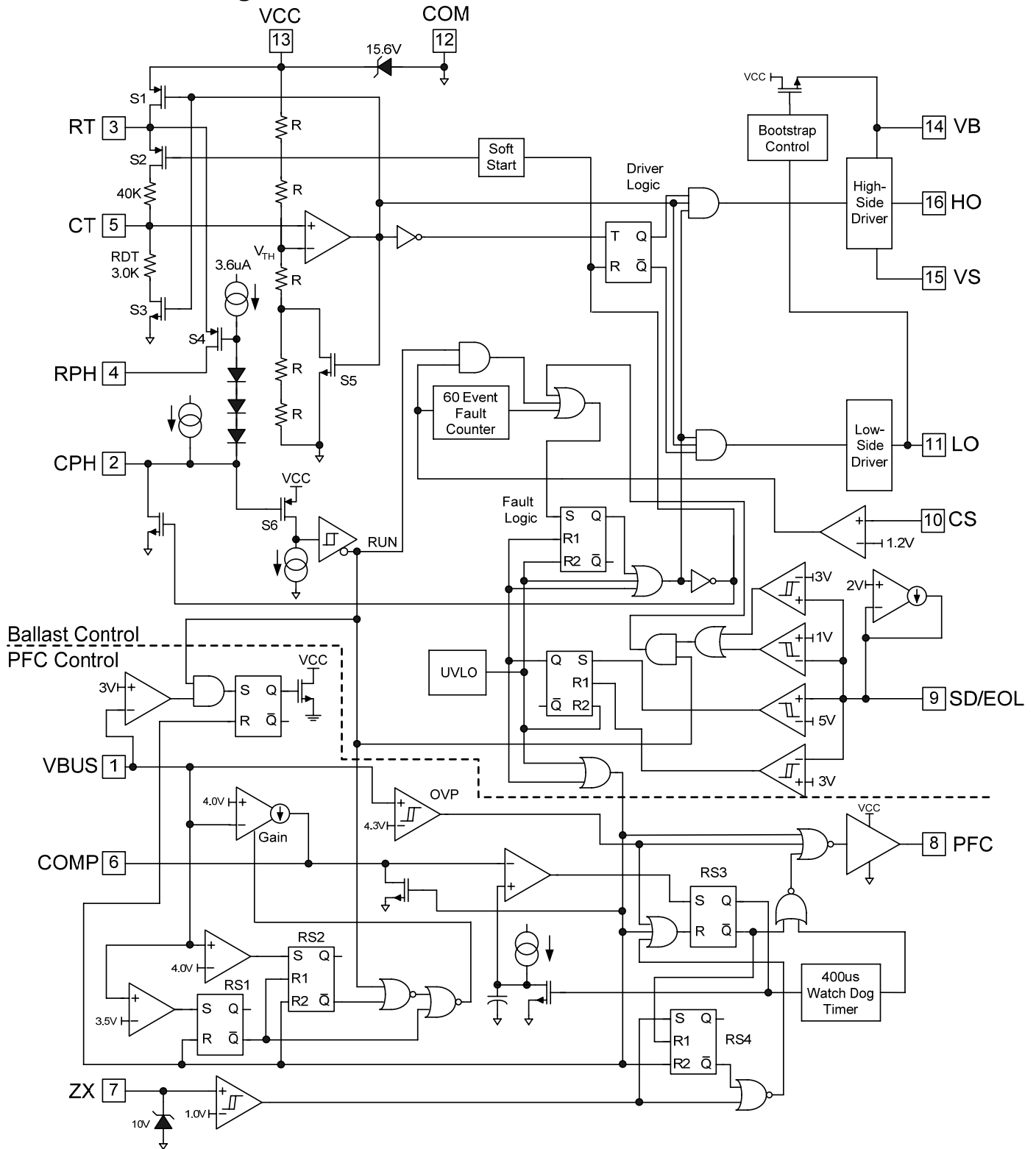

Please Note: All values shown in block diagram are typical values only

State Diagram

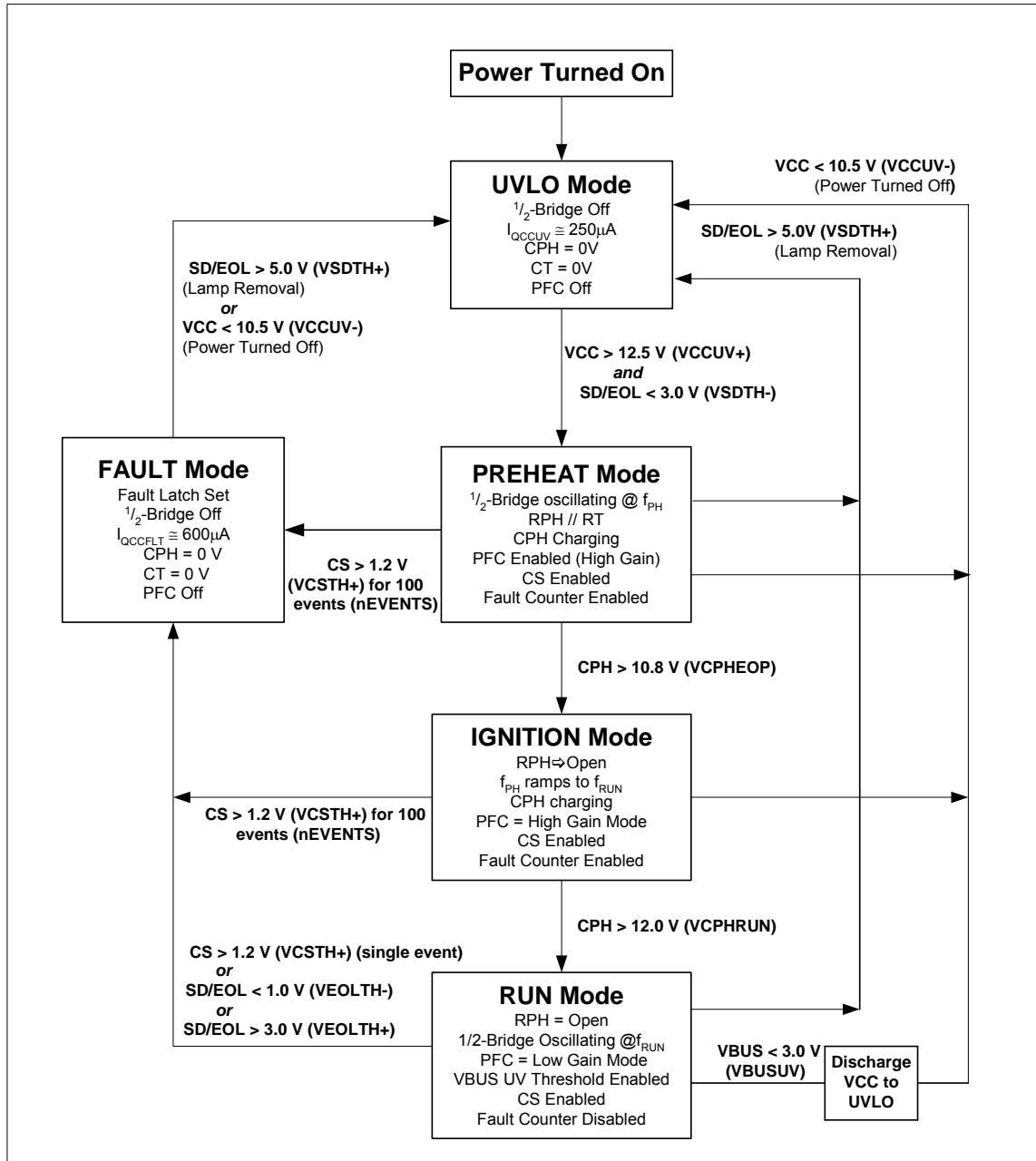

All values are typical. Applies to application diagram on page 1.

Lead Assignments & Definitions

		Pin #	Symbol	Description
		1	VBUS	DC bus sensing input
		2	CPH	Preheat timing capacitor
		3	RT	Oscillator timing resistor
		4	RPH	Preheat frequency timing resistor
		5	CT	Oscillator timing capacitor
		6	COMP	PFC error amplifier compensation
		7	ZX	PFC zero-crossing detection
		8	PFC	PFC gate driver output
		9	SD/EOL	Shutdown/end of life densing circuit
		10	CS	Half-bridge current sensing input
		11	LO	Low-side gate driver output
		12	COM	IC power & signal ground
		13	VCC	Logic & low-side gate driver supply
		14	VB	High-side gate driver floating supply
		15	VS	High voltage floating return
		16	HO	High-side gate driver output

Timing Diagrams Ballast Section

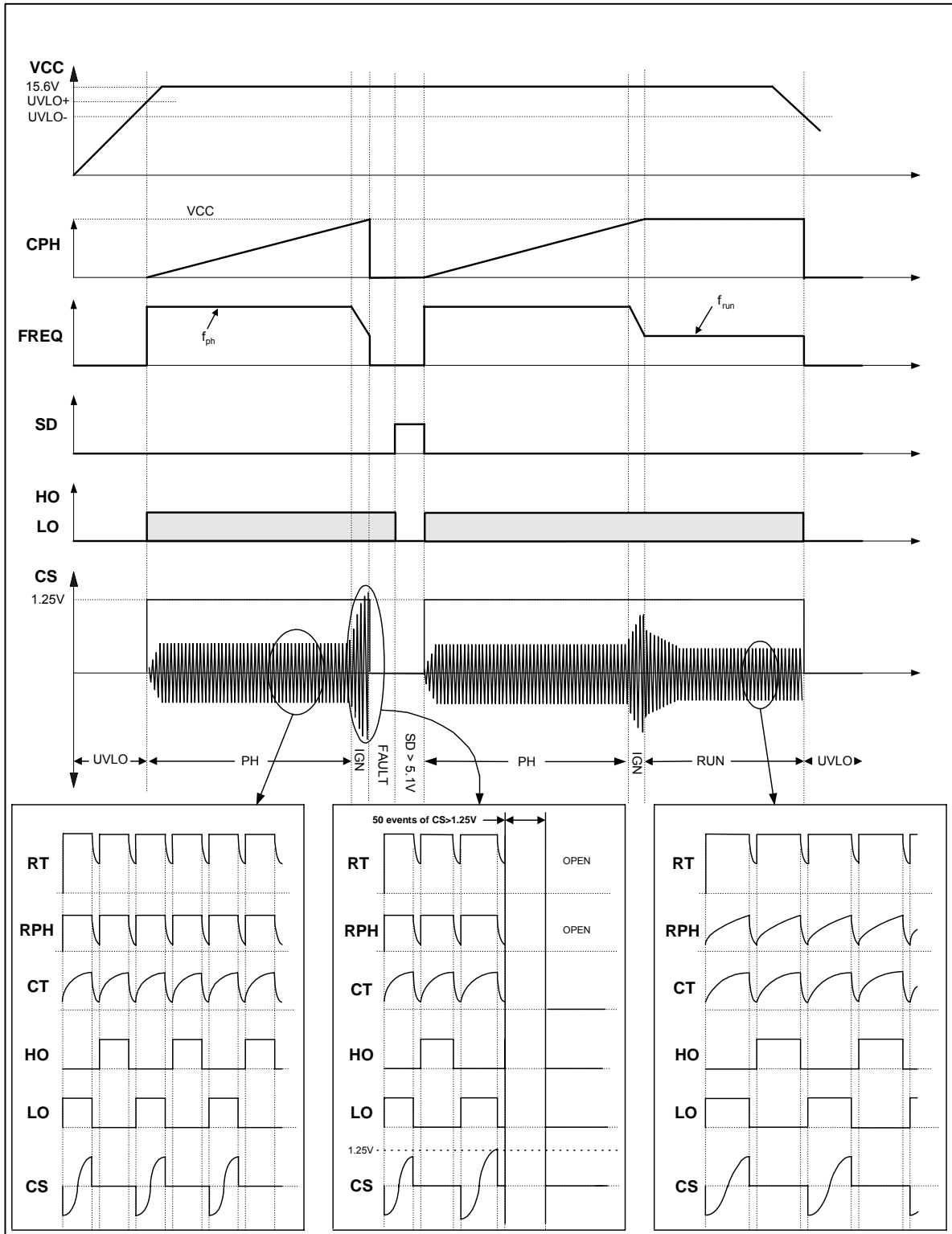

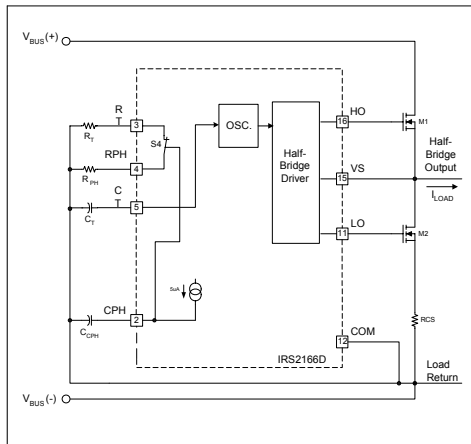

Fig. 3: Preheat circuitry

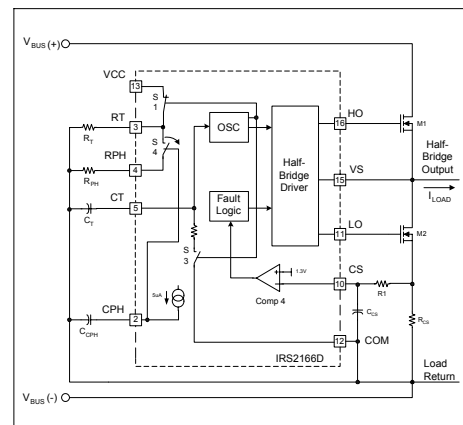

Fig.4: Ignition circuitry

gate of a p-channel MOSFET (S4) (see Fig. 4) that connects pin RPH with pin RT. As pin CPH exceeds 10.8 V (V_{CPHEOP}), the gate-to-source voltage of MOSFET S4 begins to fall below the turn-on threshold of S4. As pin CPH continues to ramp towards V_{CC} , switch S4 turns off slowly. This results in resistor R_{PH} being disconnected smoothly from resistor R_T , which causes the operating frequency to ramp smoothly from the preheat frequency, through the ignition frequency, to the final run frequency. The over-current threshold on pin CS will protect the ballast against a non-strike or open-filament lamp fault condition. The voltage on pin CS is defined by the lower half-bridge MOSFET current flowing through the external current sensing resistor R_{CS} . The resistor R_{CS} therefore programs the maximum allowable peak ignition current (and therefore peak ignition voltage) of the ballast output stage. The peak ignition current must not exceed the maximum allowable current ratings of the output stage MOSFETs. Should this voltage exceed the internal threshold of 1.20 V (V_{CSTH+}), the internal fault counter begins counting the number of sequential over-current faults (see timing diagram). If the number of over-current faults exceeds 50 (N_{EVENTS}), the IC will enter FAULT mode and gate driver outputs HO, LO and PFC will be latched low.

Run Mode (RUN)

Once the lamp has successfully ignited, the ballast enters run mode. The run mode is defined as the state the IC is in when the lamp arc is established and the lamp is being driven to a given power level. The run mode oscillating frequency is determined by the timing resistor R_T and timing capacitor C_T (see Design Equations, page 15). Should hard-switching occur at the half-bridge at any time due to an open-filament or lamp removal, the voltage across the current sensing resistor, R_{CS} , will exceed the internal threshold of 1.20 V (V_{CSTH+}) and the fault counter will begin counting (see timing diagram). Should the number of consecutive over-current faults exceed 50 (N_{EVENTS}), the IC will enter fault mode and gate driver outputs HO, LO and PFC will be latched low.

DC Bus Undervoltage Reset

Should the DC bus decrease too low during a brown-out line condition or over-load condition, the resonant output stage to the lamp can shift near or below resonance. This can produce hard-switching at the half-bridge which can damage the half-bridge switches or, the DC bus can decrease too far and the lamp can extinguish. To protect against this, the VBUS pin includes a 3.0 V undervoltage threshold (V_{BUSUV}). Should the voltage at the VBUS pin decrease below 3.0 V, V_{CC} will be discharged below the V_{CCUV-} threshold and all gate driver outputs will be latched low.

For proper ballast design, the designer should design the PFC section such that the DC bus does not drop until the AC line input voltage falls below the rated input voltage of the ballast (see PFC section). When correctly designed, the voltage measured at the VBUS pin will decrease below the internal 3.0 V threshold (V_{BUSUV}) and the ballast will turn off cleanly. The pull-up resistor to V_{CC} (R_{SUPPLY}) will then turn the ballast on again when the AC input line voltage increases to the minimum specified value causing V_{CC} to exceed V_{CCUV+} .

R_{SUPPLY} should be set to turn the ballast on at the minimum specified ballast input voltage. The PFC should then be designed such that the DC bus decreases at an input line voltage that is lower than the minimum specified ballast input voltage. This hysteresis will result in clean turn-on and turn-off of the ballast.

SD/EOL and CS Fault Mode (FAULT)

Should the voltage at the SD/EOL pin exceed 3.0 V (V_{EOLTH+}) or decrease below 1.0 V (V_{EOLTH-}) during run mode, an end-of-life (EOL) fault condition has occurred and the IC enters fault mode. LO, HO, and PFC gate driver outputs are all latched off in the 'low' state. C_{PH} is discharged to COM for resetting the preheat time. To exit fault mode, V_{CC} can be decreased below V_{CCUV-} (ballast power off) or the SD pin can be increased above 5.0 V (V_{SDTH+}) (lamp removal). Either of these will force the IC to enter UVLO mode (see State Diagram, page 7). Once

V_{CC} is above V_{CCUV+} (ballast power on) and SD is pulled above 5.0 V (V_{SDTH+}) and back below 3.0 V (V_{SDTH-}) (lamp re-insertion), the IC will enter preheat mode and begin oscillating again.

The current sense function will force the IC to enter fault mode only after the voltage at the CS pin has been greater than 1.20 V (V_{CSTH+}) for 100 (n_{EVENTS}) consecutive cycles of LO. The over-current function at the CS pin (see Fig. 5) will only consecutive cycles of LO. The over-current function at the CS pin (see Fig. 5) will only work with over-current events that occur during the LO on-time. If the over-current faults are not consecutive, then the internal fault counter will count back down each cycle when there is no fault present. Should an over-current fault occur only for a few cycles and then not occur again, the counter will eventually count back down to zero. The over-current fault counter is enabled during preheat and ignition modes and disabled during run mode. During run mode, the IC will enter fault mode after a single over-current event at the CS pin.

II. PFC Section Functional Description

In most electronic ballasts it is necessary to have the circuit act as a pure resistive load to the AC input line voltage. The degree to which the circuit matches a pure resistor is measured by the phase shift between the input voltage and input current and how well the shape of the input current waveform matches the shape of the sinusoidal input voltage. The cosine of the phase angle between the input voltage and input current is defined as the power factor (PF), and how well the shape of the input current waveform matches the shape of the input voltage is determined by the total harmonic distortion (THD). A power factor of 1.0 (maximum) corresponds to zero phase shift and a THD of 0% represents a pure sine wave (no distortion). For this reason it is desirable to have a high PF and a low THD. To achieve this, the IRS2166D includes an active power factor correction (PFC) circuit which, for an AC line input voltage, produces an AC line input current.

The control method implemented in the IRS2166D is for a boost-type converter (Fig. 6) running in critical-conduction mode (CCM). This means that during each switching cycle of the PFC MOSFET, the circuit waits until the inductor current discharges to zero before turning the PFC MOSFET on again. The PFC MOSFET is turned on and off at a much higher frequency (>10 kHz) than the line input frequency (50 Hz to 60 Hz).

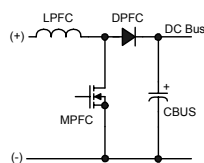

Fig. 6: Boost-type PFC circuit

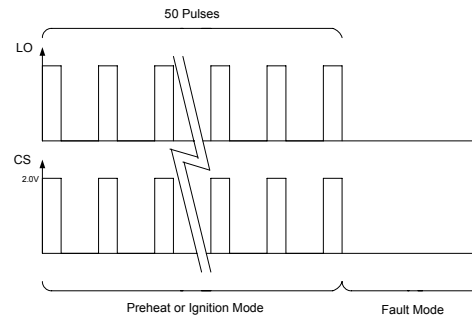

Fig. 5: CS & LO Waveforms

When the switch M_{PFC} is turned on, the inductor L_{PFC} is connected between the rectified line input (+) and (-) causing the current in L_{PFC} to charge up linearly. When M_{PFC} is turned off, L_{PFC} is connected between the rectified line input (+) and the DC bus capacitor C_{BUS} (through diode D_{PFC}) and the stored current in L_{PFC} flows into C_{BUS} . As M_{PFC} is turned on and off at a high-frequency, the voltage on C_{BUS} charges up to a specified voltage. The feedback loop of the IRS2166D regulates this voltage to a fixed value by continuously monitoring the DC voltage and adjusting the on-time of M_{PFC} accordingly. For an increasing DC bus the on-time is decreased, and for a decreasing DC bus the on-time is increased. This negative feedback control is performed with a slow loop speed and a low loop gain such that the average inductor current smoothly follows the low-frequency line input voltage for high power factor and low THD. The on-time of M_{PFC} therefore appears to be fixed (with an additional modulation to be discussed later) over several cycles of the line voltage. With a fixed on-time, and an off-time determined by the inductor current discharging to zero, the result is a system where the switching frequency is free-running and constantly changing from a high frequency near the zero crossing of the AC input line voltage, to a lower frequency at the peaks (Fig. 7).

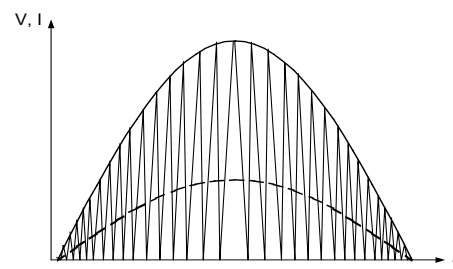

Fig. 7: Sinusoidal line input voltage (solid line), triangular PFC inductor current and smoothed sinusoidal line input current (dashed line) over one half-cycle of the line input voltage

When the line input voltage is low (near the zero crossing), the inductor current will charge up to a small amount and the discharge time will be fast resulting in a high switching frequency. When the input line voltage is high (near the peak), the inductor current will charge up to a higher amount and the discharge time will be longer giving a lower switching frequency. The triangular PFC inductor current is then smoothed by the EMI filter to produce a sinusoidal line input current.

The PFC control circuit of the IRS2166D (Fig. 8) only requires four control pins: VBUS, COMP, ZX and PFC. The VBUS pin is for sensing the DC bus voltage (via an external resistor voltage divider), the COMP pin programs the on-time of M_{PFC} and the speed of the feedback loop, the ZX pin detects when the inductor current discharges to zero (via a secondary winding from the PFC inductor), and the PFC pin is the low-side gate driver output for M_{PFC} .

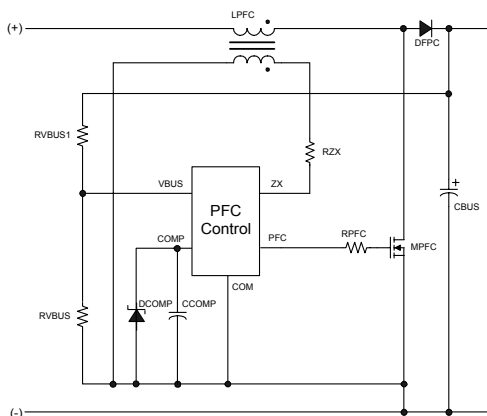

Fig. 8: IRS2166D simplified PFC control circuit

The VBUS pin is regulated against a fixed internal 4.0 V reference voltage (V_{BUSREG}) for regulating the DC bus voltage (Fig. 9). The feedback loop is performed by an operational transconductance amplifier (OTA) that sinks or sources a current to the external capacitor at the COMP pin. The resulting voltage on the COMP pin sets the threshold for the charging of the internal timing capacitor (C1) and therefore programs the on-time of M_{PFC} . During preheat and ignition modes of the ballast section, the gain of the OTA is set to a high level to raise the DC bus level quickly and to minimize the transient on the DC bus which can occur during ignition. During run mode, the gain is then decreased to a lower level necessary for achieving high power factor and low THD.

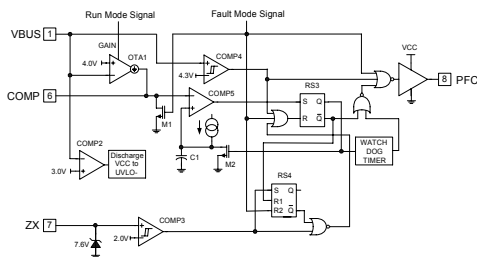

Fig. 9: IRS2166D detailed PFC control circuit

The off-time of M_{PFC} is determined by the time it takes the L_{PFC} current to discharge to zero. This zero current level is detected by a secondary winding on L_{PFC} which is connected to the ZX pin. A positive-going edge exceeding the internal 2 V threshold (V_{ZXTH+}) signals the beginning of the off-time. A negative-going edge on the ZX pin falling below ($V_{ZXTH+} - V_{ZXHYS}$) will occur when the L_{PFC} current discharges to zero which signals the end of

the off-time and M_{PFC} is turned on again (Fig. 10). The cycle repeats itself indefinitely until the PFC section is disabled due to a fault detected by the ballast section (fault mode), an over-voltage or undervoltage condition on the DC bus, or, the negative transition of ZX pin voltage does not occur. Should the negative edge on the ZX pin not occur, M_{PFC} will remain off until the watch-dog timer forces a turn-on of M_{PFC} for an on-time duration programmed by the voltage on the COMP pin. The watch-dog pulses occur every 400 μs (t_{WD}) indefinitely until a correct positive- and negative-going signal is detected on the ZX pin and normal PFC operation is resumed.

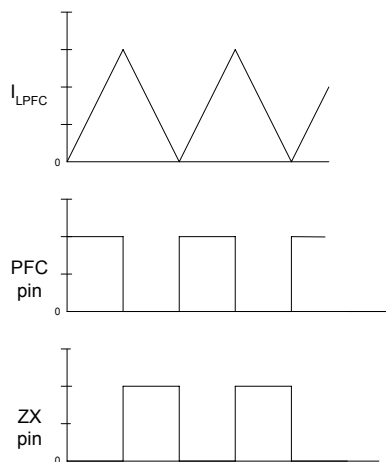

Fig. 10: L_{PFC} current, PFC pin and ZX pin timing diagram

A fixed on-time of M_{PFC} over an entire cycle of the line input voltage produces a peak inductor current which naturally follows the sinusoidal shape of the line input voltage. The smoothed averaged line input current is in phase with the line input voltage for high power factor but the total harmonic distortion (THD), as well as the individual higher harmonics, of the current can still be too high. This is mostly due to cross-over distortion of the line current near the zero-crossings of the line input voltage. To achieve low harmonics which are acceptable to international standard organizations and general market requirements, an additional on-time modulation circuit has been added to the PFC control. This circuit dynamically increases the on-time of M_{PFC} as the line input voltage nears the zero-crossings (Fig. 11). This causes the peak L_{PFC} current, and therefore the smoothed line input current, to increase slightly higher near the zero-crossings of the line input voltage. This reduces the amount of cross-over distortion in the line input current which reduces the THD and higher harmonics to low levels.

Over-Voltage Protection (OVP)

Should over-voltage occur on the DC bus causing the VBUS pin to exceed the internal 4.3 V threshold (V_{BUSOV+}), the PFC output is disabled (set to a logic 'low'). When the DC bus decreases again causing the VBUS pin to

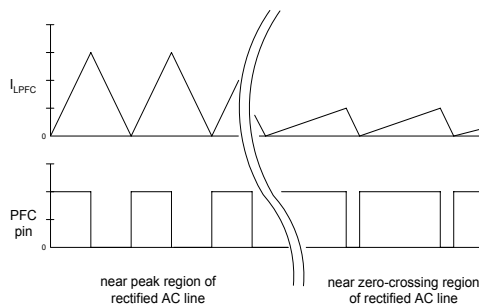

Fig. 12: On-time modulation near the zero-crossings

decrease below the internal 4.0 V threshold (V_{BUSREG}), a watch-dog pulse is forced on the PFC pin and normal PFC operation is resumed.

Undervoltage Reset (UVR)

When the line input voltage is decreased, interrupted or a brown-out condition occurs, the PFC feedback loop causes the on-time of M_{PFC} to increase in order to keep the DC bus constant. Should the on-time increase too far, the resulting peak currents in L_{PFC} can exceed the saturation current limit of L_{PFC} . L_{PFC} will then saturate and very high peak currents and di/dt levels will occur. To prevent this, the maximum on-time is limited by limiting the maximum voltage on the COMP pin with an external zener diode D_{COMP} (Fig. 8). As the line input voltage decreases, the COMP pin voltage and therefore the on-time will eventually limit. The PFC can no longer supply enough current to keep the DC bus fixed for the given load power and the DC bus will begin to drop. Decreasing the line input voltage further will cause the VBUS pin to eventually decrease below the internal 3 V threshold (V_{BUSUV}) (Fig. 9). When this occurs, V_{CC} is discharged internally below V_{CCUV-} , the IRS2166D enters UVLO mode and both the PFC and ballast sections are disabled (see State Diagram). The start-up supply resistor to V_{CC} , together with the micro-power start-up current of the IRS2166D, determines the line input turn-on voltage. This should be set such that the ballast turns on at a line voltage level above the undervoltage turn-off level, V_{CCUV+} . It is the correct selection of the value of the supply resistor to V_{CC} and the zener diode on the COMP pin that correctly program the on and off line input voltage thresholds for the ballast. With these thresholds correctly set, the ballast will turn off due to the 3.0 V undervoltage threshold (V_{BUSUV}) on the VBUS pin, and on again at a higher line input voltage (hysteresis) due to the supply resistor to V_{CC} . This hysteresis will result in a proper reset of the DC bus or re-ignition of the lamp when the DC bus is too low.

Over-Current Protection (OCP)

In case of fast on/off interruptions of the mains input voltage, or, during normal lamp ignition, the DC bus voltage level can decrease below the instantaneous rectified line voltage. Should this occur, the PFC inductor current and PFC MOSFET current can increase to high levels causing the PFC inductor to saturate and/or the PFC MOSFET to become damaged. During fast on/off interruptions of the mains input voltage, the DC bus can drop during the time when the mains input voltage is interrupted (off). Since V_{CC} is still above $UVLO-$, the IC will continue to operate and will increase the COMP pin voltage to increase the PFC MOSFET on-time due to the dropping of the DC bus. When the mains voltage returns again quickly (before V_{CC} reaches $UVLO-$), the on-time of the PFC MOSFET is too long for the given mains input voltage level resulting in high PFC inductor and MOSFET currents that can saturate the inductor and/or damage the PFC MOSFET (Fig. 13).

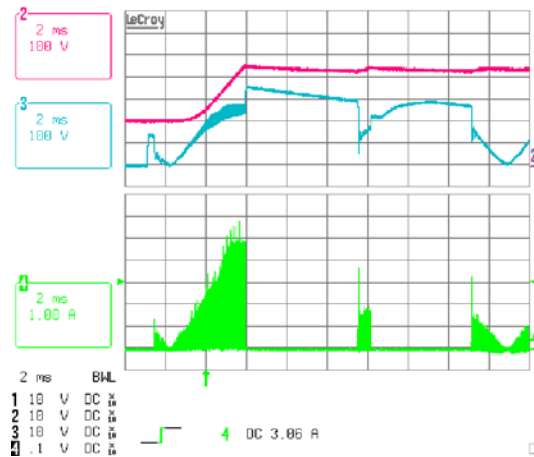

Fig. 13: High PFC inductor current during fast mains on/off (upper trace: DC Bus, 100V/div; middle trace: AC line input voltage, 100V/div; lower trace: PFC inductor current 1A/div).

During lamp ignition, the DC bus can drop below the rectified AC line voltage causing current to conduct directly from the output of the rectifier, through the PFC inductor and diode, to the DC bus capacitor. This results in a low-frequency offset of current in the PFC inductor. Since the zero-crossing detection circuit only detects the high-frequency zero-crossing of the inductor current, the PFC MOSFET will turn on again each cycle before the inductor current has reached zero. This causes the PFC to work in a continuous conduction mode and the sum of the low-frequency and high-frequency components of current can saturate the PFC inductor and/or damage the PFC MOSFET. To protect against these conditions, a current sense resistor (ROC) must be inserted between the source of the PFC MOSFET and ground, and a series diode (DOC) and limiting resistor (RD) connected from the top of the current sensing resistor to the VBUS pin (Fig. 14).

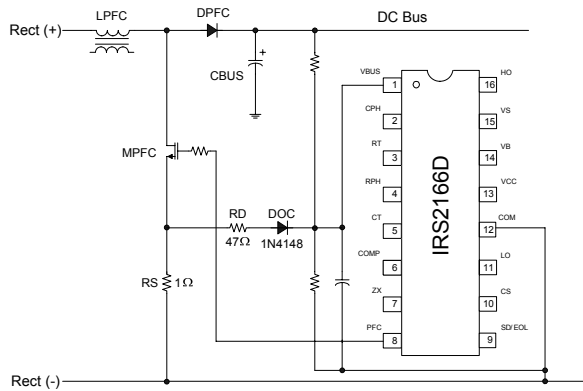

Fig. 14: External over-current protection circuit

Should high currents occur, the voltage across the current-sensing resistor will exceed 4.3V over-voltage protection threshold at the VBUS pin and the PFC MOSFET will turn off safely limiting the current. The watch-dog timer will then restart the PFC as normal (Fig. 15). The current sensing resistor value should be selected such that the over-current protection does not false trip during normal operation over the entire line voltage and load range. A current-sensing resistor value of 1.0 ohm, for example, will set the over-current threshold to about 5 A peak.

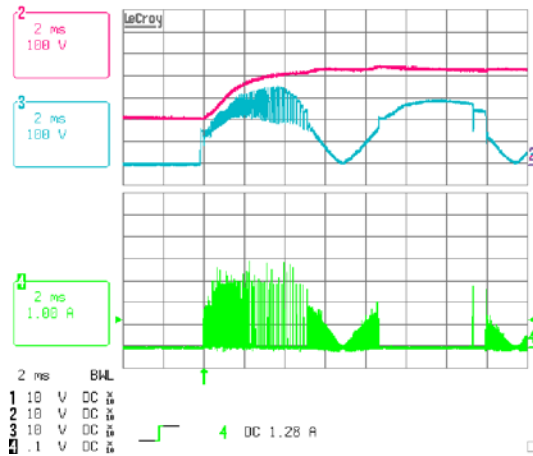

Fig. 15: PFC inductor current limited using over-current protection circuit (upper trace: DC Bus, 100V/div; middle trace: AC line input voltage, 100V/div; lower trace: PFC inductor current 1A/div).

The effect that these line and load conditions have on the performance of the ballast depends on the saturation level of the PFC inductor, the selection of the PFC MOSFET, the DC bus capacitor value, the maximum on-time limit set by the DZCOMP, and, how fast VCC decreases below UVLO-.

For these reasons, the ballast designer should perform these mains interrupt and ignition tests carefully to determine the correct current-sensing resistor value and determine the robustness of their final design.

Ballast Design Equations

Note: The results from the following design equations can differ slightly from experimental measurements due to IC tolerances, component tolerances, and oscillator over-and under-shoot due to internal comparator response time.

Step 1: Program Deadtime

The deadtime between the gate driver outputs HO and LO is programmed with timing capacitor C_T and an internal deadtime resistor R_{DT} . The deadtime is the discharge time of capacitor C_T from $3/5 V_{CC}$ to $1/3 V_{CC}$ and is given as:

$$t_{DT} = C_T \cdot 1475 \quad [s] \quad (1)$$

or

$$C_T = \frac{t_{DT}}{1475} \quad [F] \quad (2)$$

Step 2: Program Run Frequency

The final run frequency is programmed with timing resistor R_T and timing capacitor C_T . The charge time of capacitor C_T from $1/3 V_{CC}$ to $3/5 V_{CC}$ determines the on-time of HO and LO gate driver outputs. The run frequency is therefore given as:

$$f_{RUN} = \frac{1}{2 \cdot C_T (0.51 \cdot R_T + 1475)} \quad [Hz] \quad (3)$$

or

$$R_T = \frac{1}{1.02 \cdot C_T \cdot f_{RUN}} - 2892 \quad [\Omega] \quad (4)$$

Step 3: Program Preheat Frequency

The preheat frequency is programmed with timing resistors R_T and R_{PH} , and timing capacitor C_T . The timing resistors are connected in parallel internally for the duration of the preheat time. The preheat frequency is therefore given as:

$$f_{PH} = \frac{1}{2 \cdot C_T \cdot \left(\frac{0.51 \cdot R_T \cdot R_{PH}}{R_T + R_{PH}} + 1475 \right)} \quad [\text{Hz}] \quad (5)$$

or

$$R_{PH} = \frac{\left(\frac{1}{1.02 \cdot C_T \cdot f_{PH}} - 2892 \right) \cdot R_T}{R_T - \left(\frac{1}{1.02 \cdot C_T \cdot f_{PH}} - 2892 \right)} \quad [\Omega] \quad (6)$$

Step 4: Program Preheat Time

The preheat time is defined by the time it takes for the capacitor on pin CPH to charge up to 12 V. An internal current source of 3.6 μA (I_{CPH}) flows out of pin CPH. The preheat time is therefore given as:

$$t_{PH} = C_{PH} \cdot 2.6e6 \quad [\text{s}] \quad (7)$$

or

$$C_{PH} = t_{PH} \cdot 0.385e-6 \quad [\text{F}] \quad (8)$$

Step 5: Program Maximum Ignition Current

The maximum ignition current is programmed with the external resistor R_{CS} and an internal threshold of 1.20 V. This threshold determines the over-current limit of the ballast, which can be exceeded when the frequency ramps down towards resonance during ignition and the lamp does not ignite. The maximum ignition current is given as:

$$I_{IGN} = \frac{VCSTH+}{R_{CS}} \quad [\text{A}] \quad (9)$$

or

$$R_{CS} = \frac{VCSTH+}{I_{IGN}} \quad [\Omega] \quad (10)$$

PFC Design Equations

Step1: Calculate PFC inductor value:

$$L_{PFC} = \frac{(VBUS - \sqrt{2} \cdot VAC_{MIN}) \cdot VAC_{MIN}^2 \cdot \eta}{2 \cdot f_{MIN} \cdot P_{OUT} \cdot VBUS} \quad [\text{H}] \quad (1)$$

where,

$VBUS$ = DC bus voltage

VAC_{MIN} = Minimum rms AC input voltage

η = PFC efficiency (typically 0.95)

f_{MIN} = Minimum PFC switching frequency at minimum AC input voltage

P_{OUT} = Ballast output power

Step 2: Calculate peak PFC inductor current:

$$i_{PK} = \frac{2 \cdot \sqrt{2} \cdot P_{OUT}}{VAC_{MIN} \cdot \eta} \quad [\text{A}] \quad (2)$$

Note: The PFC inductor must not saturate at i_{PK} over the specified ballast operating temperature range. Proper core sizing and air-gapping should be considered in the inductor design.

Step 3: Calculate maximum on-time:

$$t_{ONMAX} = \frac{2 \cdot P_{OUT} \cdot L_{PFC}}{VAC_{MIN}^2 \cdot \eta} \quad [\text{s}] \quad (3)$$

Step 4: Calculate maximum COMP voltage:

$$V_{COMPMAX} = \frac{t_{ONMAX}}{0.9E-6} \quad [\text{V}] \quad (4)$$

Step 5: Select zener diode D_{COMP} value:

$$D_{COMP} \text{ zener voltage} \approx V_{COMPMAX} \quad [\text{V}] \quad (5)$$

Step 6: Calculate resistor R_{SUPPLY} value:

$$R_{SUPPLY} = \frac{VAC_{MIN} + 10}{IQCCUV} \quad [\Omega] \quad (6)$$

Step 7: Calculate resistor R_{OC} value:

$$R_{OC} = \frac{5}{I_{PFCMAX_PK}} \quad [\Omega] \quad (7)$$

CaseOutlines

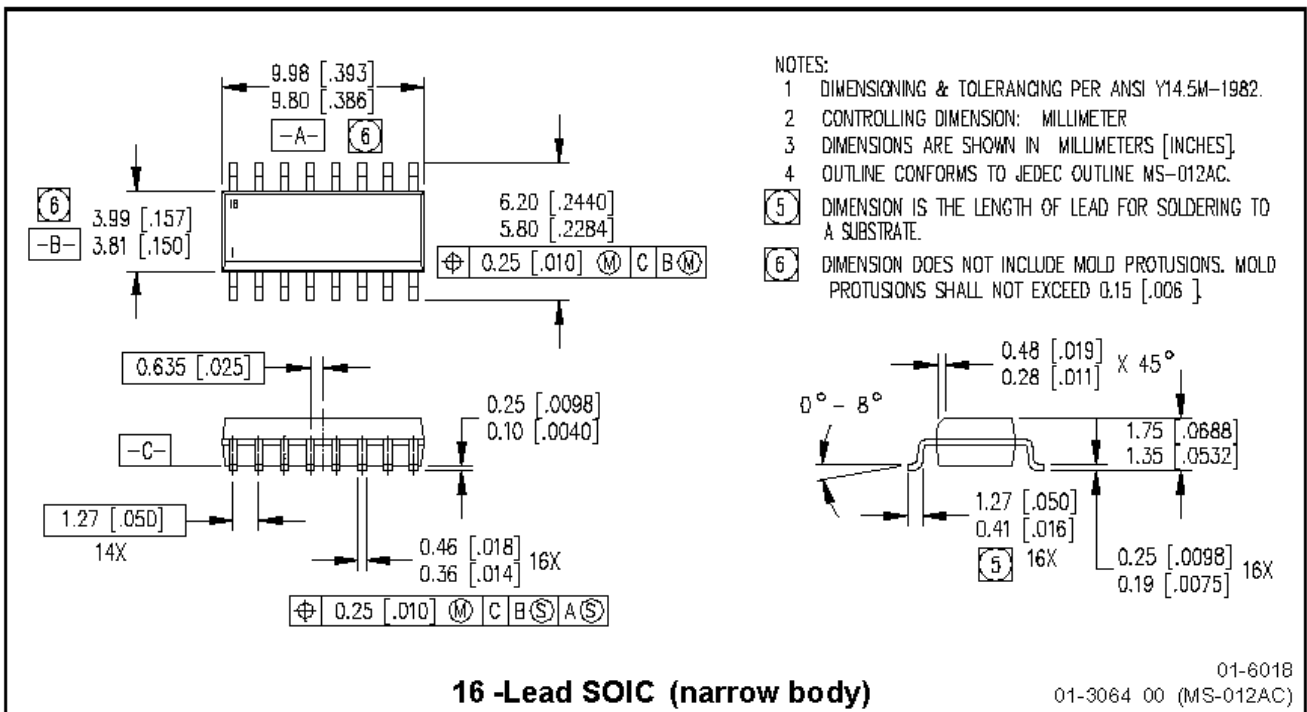
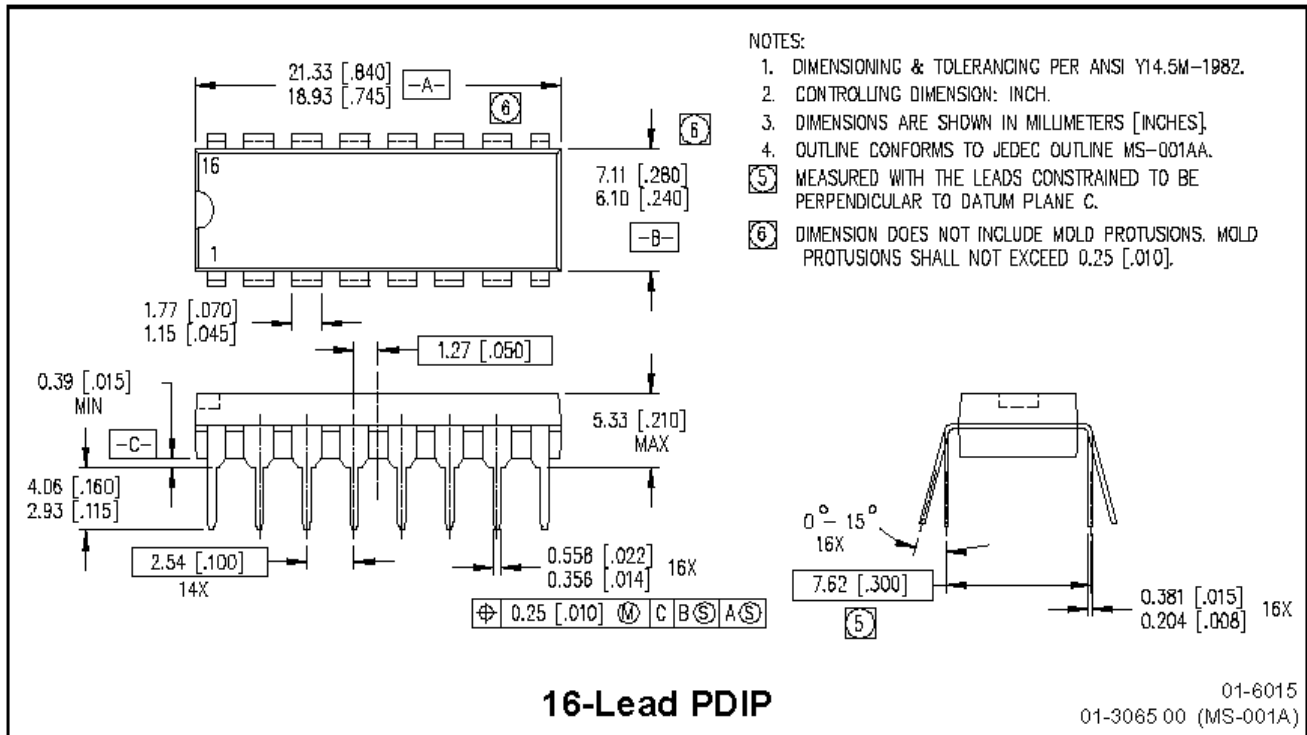

16-Lead Tape & Reel

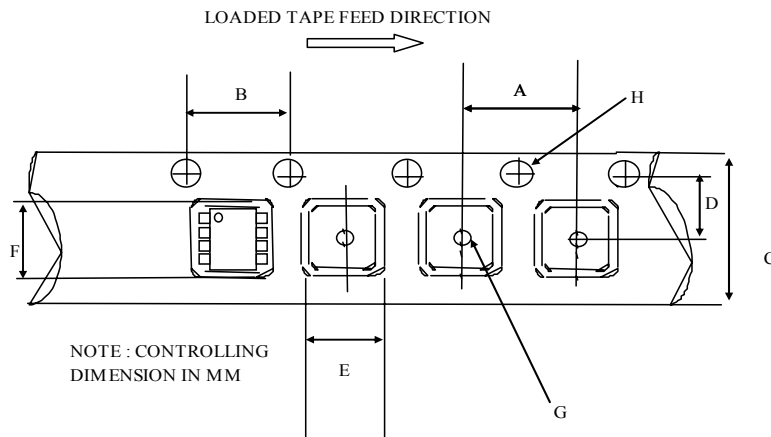

CARRIER TAPE DIMENSION FOR 16SOICN

Code	Metric		Imperial	
	Min	Max	Min	Max
A	7.90	8.10	0.311	0.318
B	3.90	4.10	0.153	0.161
C	15.70	16.30	0.618	0.641
D	7.40	7.60	0.291	0.299
E	6.40	6.60	0.252	0.260
F	10.20	10.40	0.402	0.409
G	1.50	n/a	0.059	n/a
H	1.50	1.60	0.059	0.062

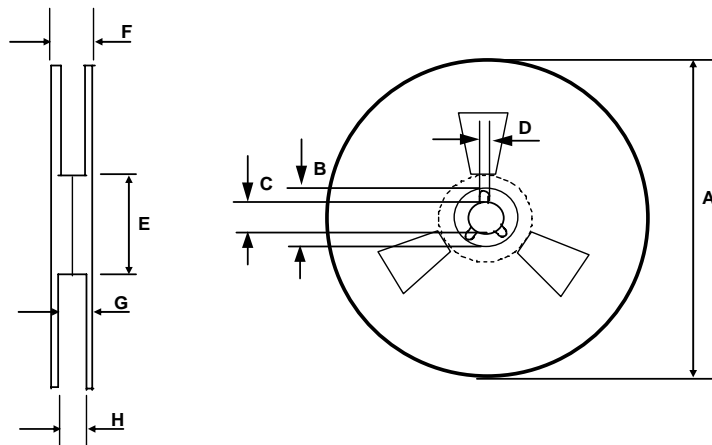

REEL DIMENSIONS FOR 16SOICN

Code	Metric		Imperial	
	Min	Max	Min	Max
A	329.60	330.25	12.976	13.001
B	20.95	21.45	0.824	0.844
C	12.80	13.20	0.503	0.519
D	1.95	2.45	0.767	0.096
E	98.00	102.00	3.858	4.015
F	n/a	22.40	n/a	0.881
G	18.50	21.10	0.728	0.830
H	16.40	18.40	0.645	0.724

LEAD-FREE PART MARKING INFORMATION

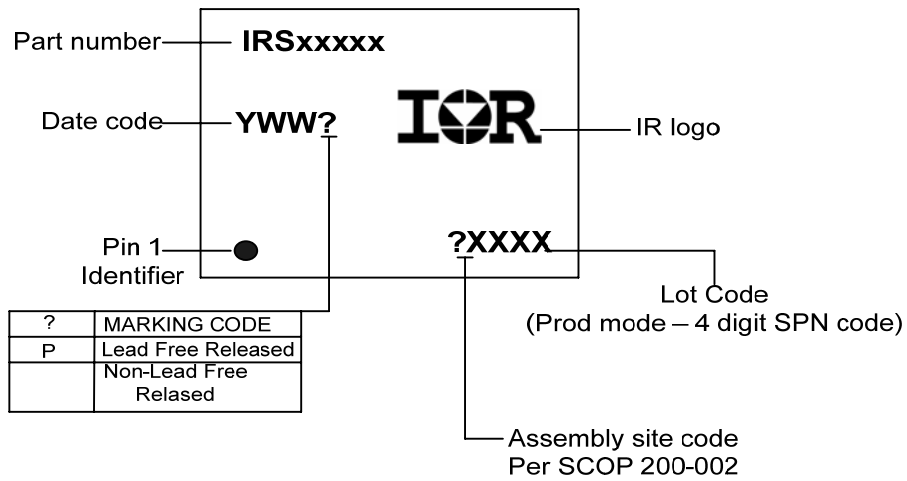

ORDER INFORMATION

- 16-Lead PDIP IRS2166DPbF
- 16-Lead SOIC IRS2166DSPbF
- 16-Lead SOIC Tape & Reel IRS2166DSTRPbF

X-ON Electronics

Largest Supplier of Electrical and Electronic Components

Click to view similar products for [Gate Drivers](#) category:

Click to view products by [Infineon](#) manufacturer:

Other Similar products are found below :

[00053P0231](#) [56956](#) [57.404.7355.5](#) [LT4936](#) [57.904.0755.0](#) [5882900001](#) [00600P0005](#) [00-9050-LRPP](#) [00-9090-RDPP](#) [5951900000](#) [01-1003W-10/32-15](#) [0131700000](#) [00-2240](#) [LTP70N06](#) [LVP640](#) [5J0-1000LG-SIL](#) [LY1D-2-5S-AC120](#) [LY2-US-AC240](#) [LY3-UA-DC24](#) [00576P0020](#) [00600P0010](#) [LZN4-UA-DC12](#) [LZNQ2M-US-DC5](#) [LZNQ2-US-DC12](#) [LZP40N10](#) [00-8196-RDPP](#) [00-8274-RDPP](#) [00-8275-RDNP](#) [00-8722-RDPP](#) [00-8728-WHPP](#) [00-8869-RDPP](#) [00-9051-RDPP](#) [00-9091-LRPP](#) [00-9291-RDPP](#) [0207100000](#) [0207400000](#) [01312](#) [0134220000](#) [60713816](#) [M15730061](#) [61161-90](#) [61278-0020](#) [6131-204-23149P](#) [6131-205-17149P](#) [6131-209-15149P](#) [6131-218-17149P](#) [6131-220-21149P](#) [6131-260-2358P](#) [6131-265-11149P](#) [CS1HCPU63](#)