

Magnetic Replacement Ballast IC

Features

- Ballast control plus half-bridge driver in one IC
- Single-stage topology (no PFC stage required)
- High PF and low THD
- Preheat, ignition and running lamp modes
- Closed-loop lamp current control
- Half-bridge NZVS protection
- Adaptive dead-time
- Lamp insert auto-restart
- Internal bootstrap MOSFET
- Micro-power start-up current
- 15.6V internal zener clamp on VCC
- Excellent ESD and latch immunity
- RoHS compliant
- 8-pin SO8 package

Applications

- Magnetic replacement electronic ballast
- Low cost electronic ballast

Description

This IC takes full advantage of IR's patented ballast and high-voltage technologies to realize a simple, high-performance magnetic ballast replacement solution. The IC includes a novel single-stage circuit topology and control method to achieve high power factor and low THD without a PFC stage or any electrolytic capacitors. A single high-voltage pin senses the half-bridge voltage to perform necessary protection functions. Closed-loop control of the lamp current provides constant lamp brightness over a wide line input voltage range. Combining these high-voltage control algorithms in a single 8-pin IC results in a large reduction in component count, an increase in manufacturability and reliability, a reduced design cycle time, while maintaining high ballast system performance.

Package Options



8-Lead SOIC

Application Diagram

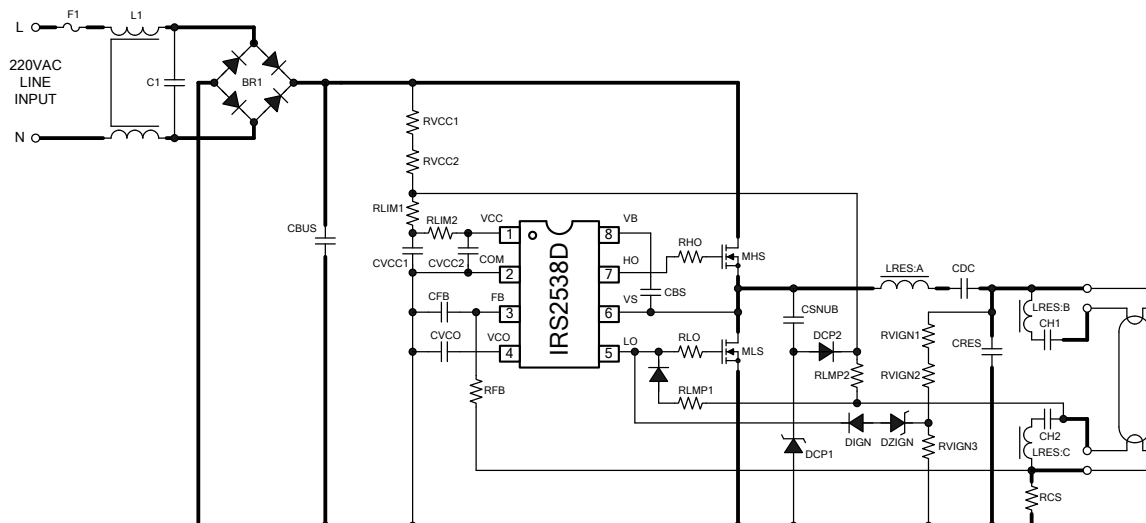

Ordering Information

Base Part Number	Package Type	Standard Pack		Orderable Part Number
		Form	Quantity	
IRS2538DSPBF	SO8N	Tape and Reel	2500	IRS2538DSTRPBF

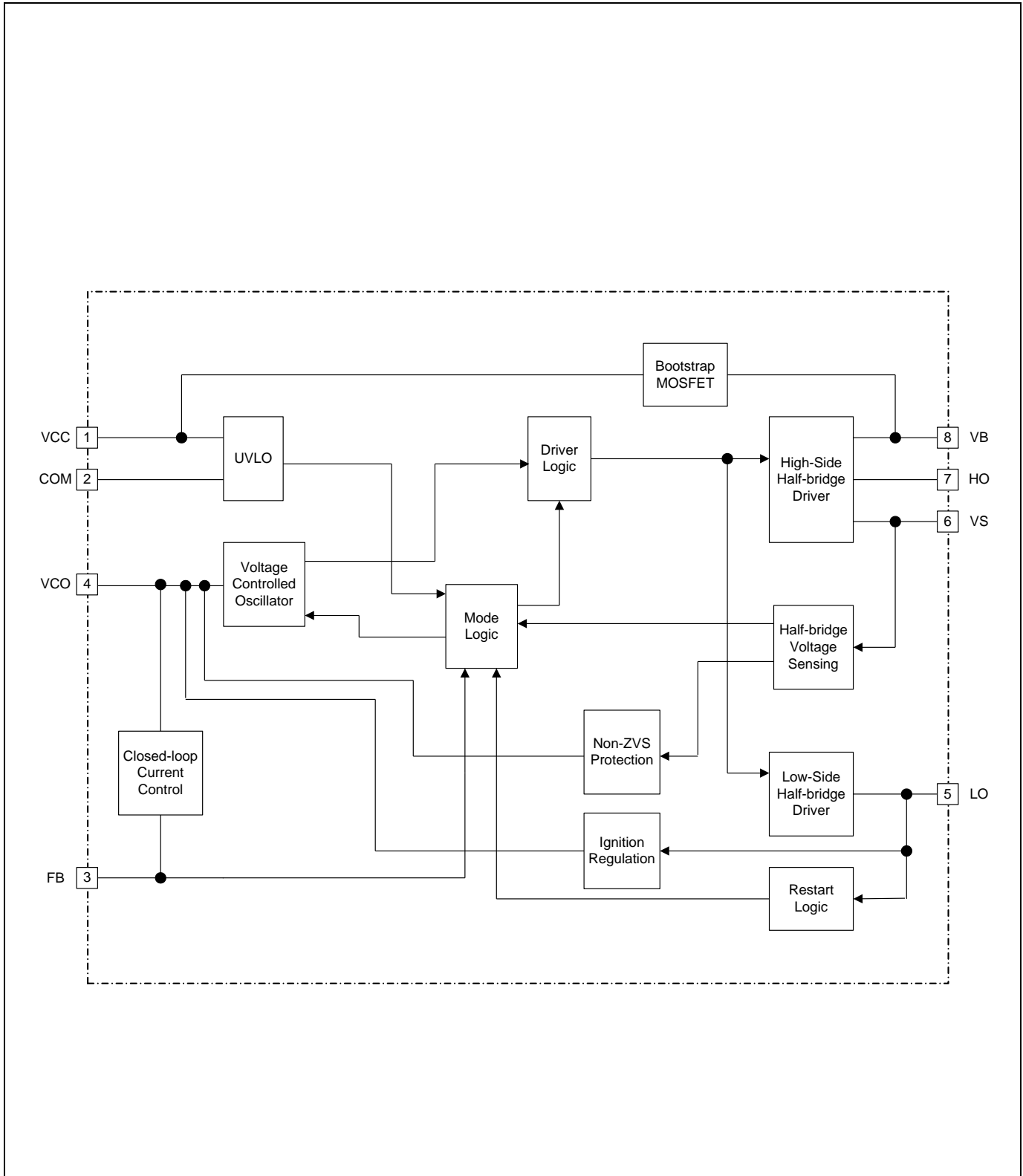
Functional Block Diagram

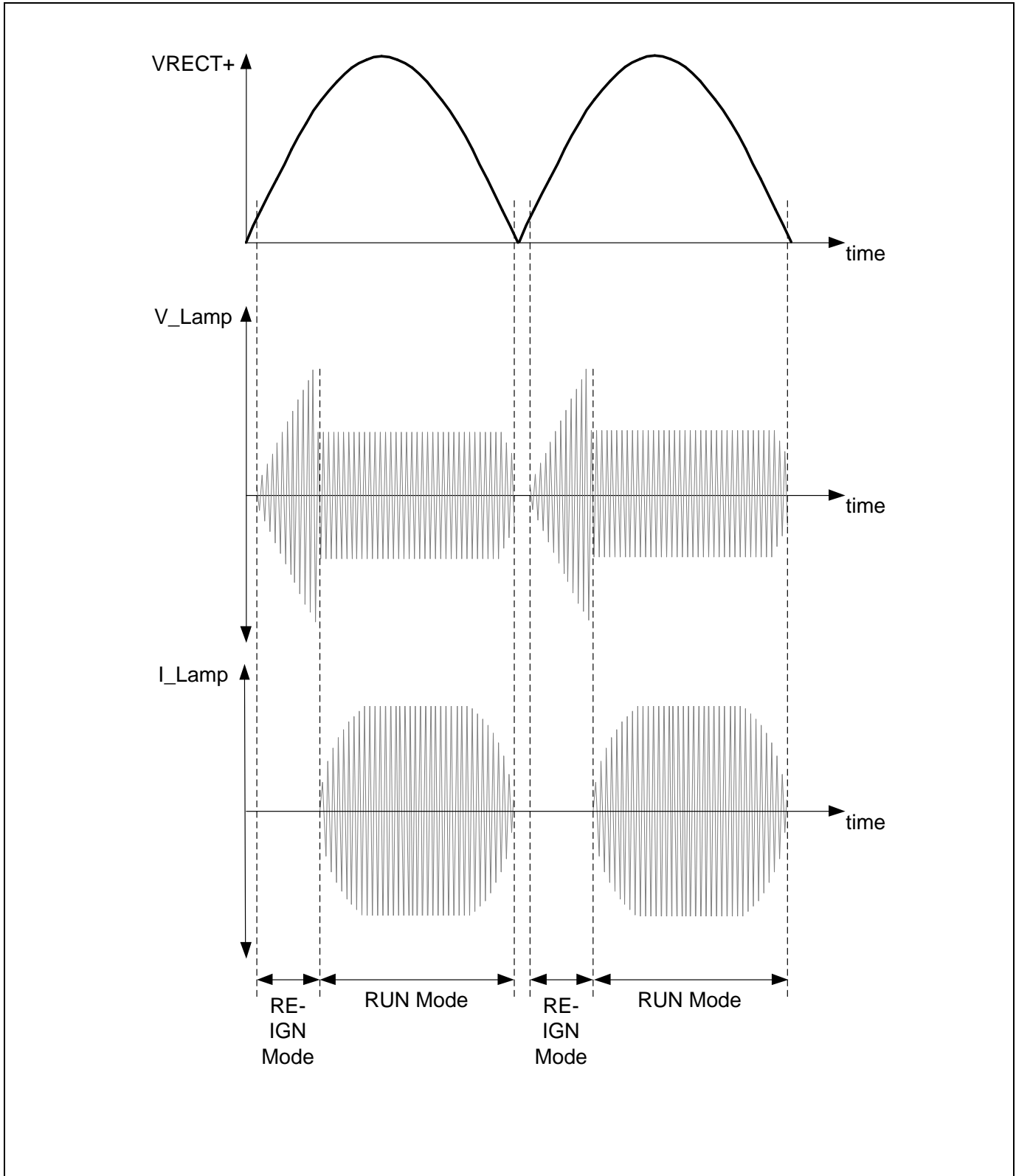
Timing Diagram

Qualification Information[†]

Qualification Level		Industrial ^{††} (per JEDEC JESD 47E)	
		Comments: This family of ICs has passed JEDEC's Industrial qualification. IR's Consumer qualification level is granted by extension of the higher Industrial level.	
Moisture Sensitivity Level		SOIC8N	MSL2 ^{†††} (per IPC/JEDEC J-STD-020C)
ESD	Machine Model	Class A (per JEDEC standard EIA/JESD22-A115-A)	
	Human Body Model	Class IC (per EIA/JEDEC standard JESD22-A114-B)	
IC Latch-Up Test		Class I, Level A (per JESD78A)	
RoHS Compliant		Yes	

† Qualification standards can be found at International Rectifier's web site <http://www.irf.com/>

†† Higher qualification ratings may be available should the user have such requirements. Please contact your International Rectifier sales representative for further information.

††† Higher MSL ratings may be available for the specific package types listed here. Please contact your International Rectifier sales representative for further information.

Absolute Maximum Ratings

Absolute maximum ratings indicate sustained limits beyond which damage to the device may occur. All voltage parameters are absolute voltages referenced to COM, all currents are defined positive into any pin. The thermal resistance and power dissipation ratings are measured under board mounted and still air conditions.

Symbol	Definition	Min.	Max.	Units
VB	High-Side Floating Supply Voltage	-0.3	625	V
VS	High-Side Floating Supply Offset Voltage	VB - 25	VB + 0.3	
VHO	High-Side Floating Output Voltage	VS - 0.3	VB + 0.3	
VLO	Low-Side Output Voltage	-0.3	VCC + 0.3	
VVCO	VCO Input Voltage	-0.3	6	
VFB	FB Input Voltage	-0.3	VCC + 0.3	
ICC	Supply Current [†]	---	20	mA
IOMAX	Maximum allowable current at LO, HO and PFC due to external power transistor Miller effect.	-500	500	
dV_S/dt	Allowable VS Pin Voltage Slew Rate	-50	50	V/ns
PD	Maximum Power Dissipation @ T _A ≤ +25°C, 8-Pin SOIC	---	0.625	W
R_{θJA}	Thermal Resistance, Junction to Ambient, 8-Pin SOIC	---	128	°C/W
T_J	Junction Temperature	-55	150	°C
T_S	Storage Temperature	-55	150	
T_L	Lead Temperature (Soldering, 10 seconds)	---	300	

†: This IC contains a voltage clamp structure between the chip VCC and COM which has a nominal breakdown voltage of 15.6V. This supply pin should not be driven by a DC, low impedance power source greater than the VCLAMP specified in the Electrical Characteristics section.

Recommended Operating Conditions

For proper operation the device should be used within the recommended conditions.

Symbol	Definition	Min.	Max.	Units
VBS	High-Side Floating Supply Voltage	VCC - 0.7	VCLAMP	V
VS	Steady State High-Side Floating Supply Offset Voltage	-3.0 ^{††}	600	V
VCC	Supply Voltage	VCCUV+ + 0.1V	VCLAMP	V
ICC	Supply Current	†††	5	mA
TJ	Junction Temperature	-40	125	°C

††: Care should be taken to avoid output switching conditions where the VS node rings below COM by more than 5V.

†††: Enough current should be supplied to the VCC pin of the IC to keep the internal 15.6V zener diode regulating at its voltage, VCLAMP.

Electrical Characteristics

V_{CC}=V_{BS}=14V, V_S=0V and T_A = 25°C unless otherwise specified. The output voltage and current (V_O and I_O) parameters are referenced to COM and are applicable to the respective HO and LO output pins.

Symbol	Definition	Min	Typ	Max	Units	Test Conditions
Low Voltage Supply Characteristics						
V _{CLAMP}	V _{CC} Zener Clamp Voltage	14.5	15.5	16.5	V	I _{CC} = 10mA
V _{CCUV+}	Rising V _{CC} UVLO Threshold	11.2	11.8	12.3		
V _{CCUV-}	Falling V _{CC} UVLO Threshold	8.5	9.0	9.5		
V _{CCUVHYS}	V _{CC} UVLO Hysteresis	---	2.8	---		
I _{QCCUV}	Micro-power Startup V _{CC} Supply Current	---	---	125	μA	V _{CC} = V _{CCUV+} - 500mV
I _{CCfmin}	f _{MIN} V _{CC} Supply Current	---	2.2	---	mA	V _{CO} ≥ 5V
I _{CCfmax}	f _{MAX} V _{CC} Supply Current	---	3.2	---		V _{CO} = 0V
I _{QCCFLT}	Fault Mode V _{CC} Supply Current	---	---	300	μA	MODE = FAULT, V _{CC} = V _{CCUV+}
Floating Supply Characteristics						
I _{QBS}	Quiescent V _{BS} Supply Current	---	28	---	μA	
V _{BSUV+}	Rising V _{BS} Supply UVLO Threshold	---	7.2	---	V	
V _{BSUV-}	Falling V _{BS} Supply UVLO Threshold	---	6.8	---		
I _{LK}	Offset Supply Leakage Current	---	---	170	μA	V _B = V _S = 600V
Ballast Control Characteristics						
f _{MIN}	Minimum Output Frequency	17.4	18.3	19.4	kHz	V _{CO} ≥ 5V
f _{MAX}	Maximum Output Frequency	80.9	85.6	91.3		V _{CO} = 0V
d	Duty Cycle	---	50	---	%	
DT _{MIN}	Minimum Output Dead-time (HO or LO)	---	0.48	---	μs	
DT _{MAX}	Maximum Output Dead-time (HO or LO)	---	1.35	---		
V _{LOSD+}	LO Pin Shutdown Threshold	---	13.3	---	V	MODE = FAULT
V _{LOSD-}	LO Pin Re-start Threshold	---	11.1	---		
V _{LORSTHYS}	LO Pin Restart Hysteresis	---	2.2	---		
V _{ZVSTH}	V _S Non-ZVS Detection Threshold	---	4.6	---		

Electrical Characteristics

VCC=VBS=14V, VS=0V and TA = 25°C unless otherwise specified. The output voltage and current (VO and IO) parameters are referenced to COM and are applicable to the respective HO and LO output pins.

Symbol	Definition	Min	Typ	Max	Units	Test Conditions
PREHEAT Mode Characteristics						
T _{PH}	Preheat Time	---	2.0	---	sec	f _{Line} = 60Hz, GBD
		---	2.4	---		f _{Line} = 50Hz, GBD
IGNITION Mode Characteristics						
V _{LOIGN+}	LO Pin Ignition Voltage Threshold	---	VCC	---	V	MODE = RE-IGN
RUN Mode Characteristics						
V _{FBREG+}	FB Pin Regulation Threshold	0.93	1.0	1.09	V	
V _{IGNDET+}	FB Pin Ignition Detection Threshold	0.1	0.2	0.3		
VCO Control Characteristics						
I _{VCO}	VCO Charging Current	9.8	10.8	11.7	uA	MODE = IGN
I _{VCO_ZVS}	ZVS VCO Discharging Current	---	400	---		

Electrical Characteristics

VCC=VBS=14V, VS=0V and TA = 25°C unless otherwise specified. The output voltage and current (VO and IO) parameters are referenced to COM and are applicable to the respective HO and LO output pins.

Symbol	Definition	Min	Typ	Max	Units	Test Conditions
Gate Driver Output Characteristics (HO and LO)						
<i>V_{OH_LO1}</i>	LO Leading Edge High-Level Output Voltage	---	12.6	---	V	I _o = 0A
<i>V_{OH_LO2}</i>	LO Steady State High-Level Output Voltage	---	10.8	---		
<i>V_{OH_HO}</i>	HO High-Level Output Voltage	---	VBS	---		
<i>V_{OL}</i>	Low-Level Output Voltage	---	COM	---		
<i>t_R</i>	Output Rise Time	---	120	---	ns	C _{HO} =1nF, C _{LO} =1nF
<i>t_F</i>	Output Fall Time	---	50	---		
<i>I_{o+}</i>	Output Source Current	---	180	---	mA	
<i>I_{o-}</i>	Output Sink Current	---	260	---		
Bootstrap FET Characteristics						
<i>V_{B_ON}</i>	VB when the bootstrap FET is on	---	14.0	---	V	LO = 'HIGH'
<i>I_{B_CAP}</i>	VB source current when FET is on	---	23.0	---	mA	CBS = 0.1uF
<i>I_{B_10V}</i>	VB source current when FET is on	---	4.2	---		VB = 10V

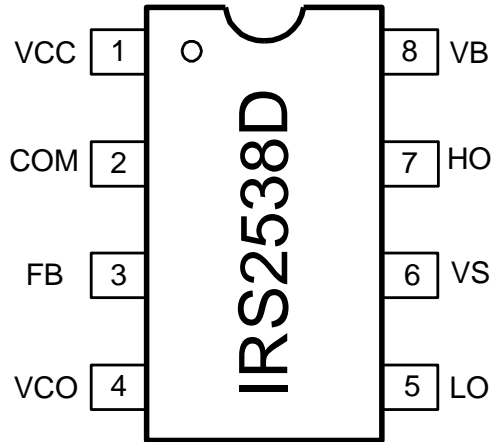
Pin Assignments and Definitions

Name	No.	Description
VCC	1	Logic and internal gate drive supply voltage
COM	2	IC power and signal ground
FB	3	Lamp current feedback input
VCO	4	Voltage-controlled oscillator (VCO) input
LO	5	Half-bridge low-side gate driver output
VS	6	High voltage floating supply return and half-bridge sensing input
HO	7	High-side gate driver output
VB	8	High-side gate driver floating supply

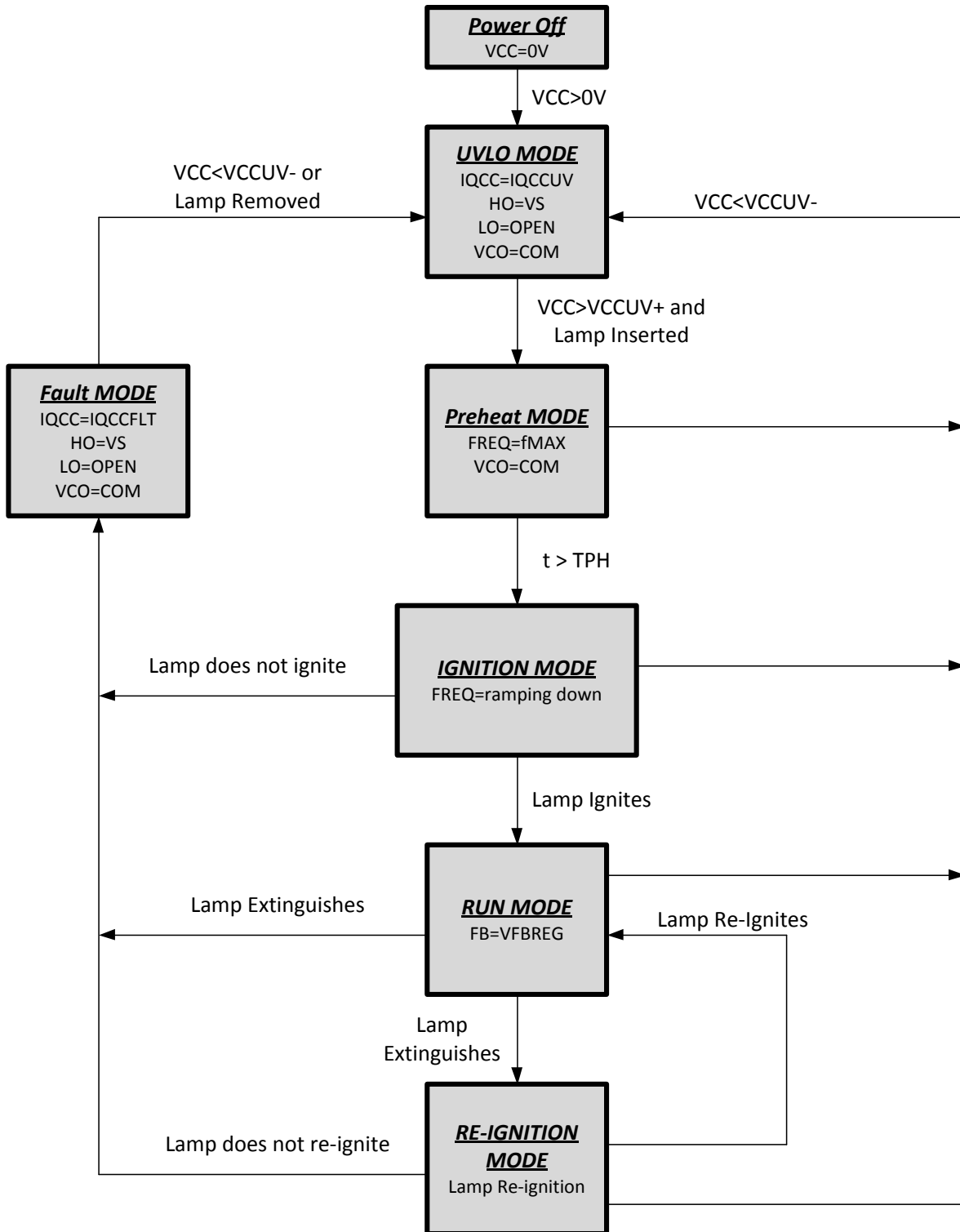
State Diagram

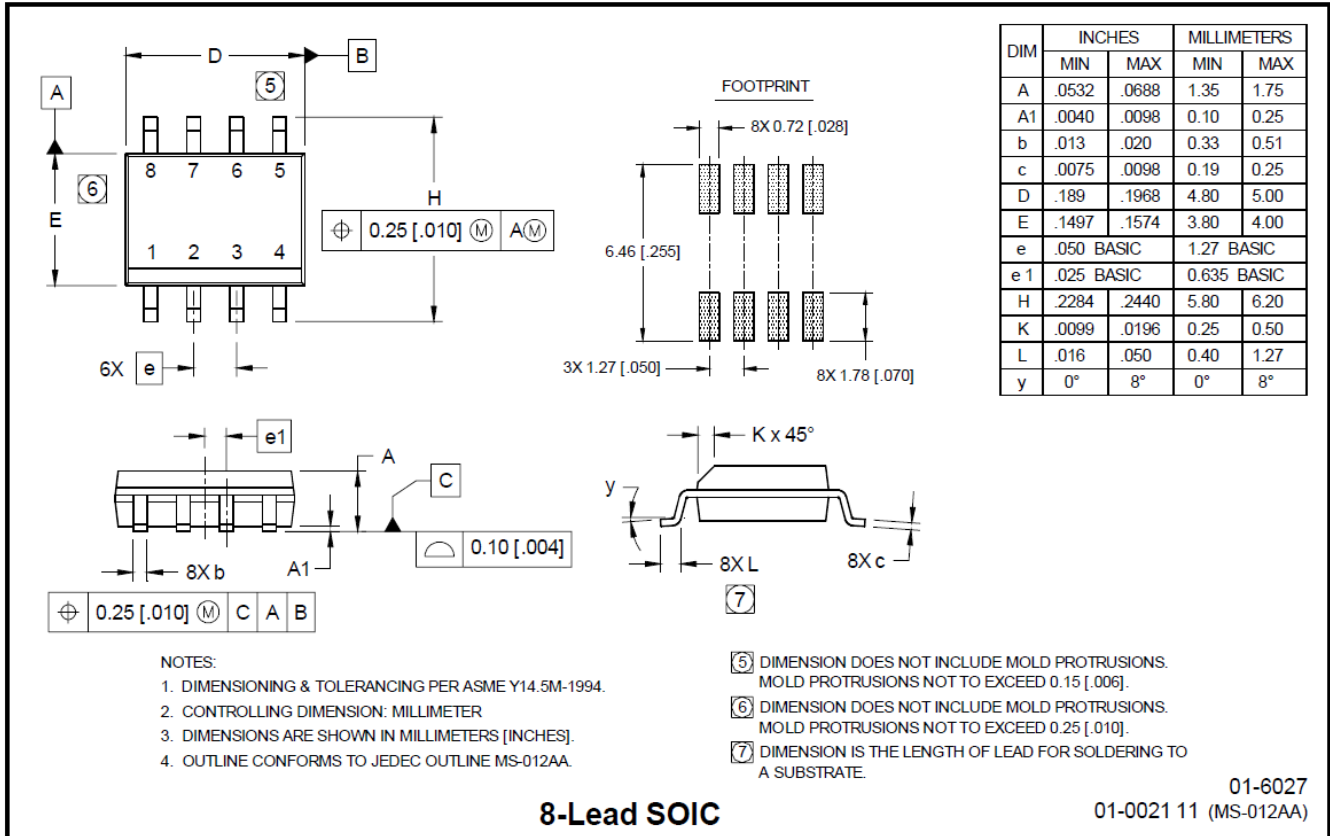
Package Details: SO8N

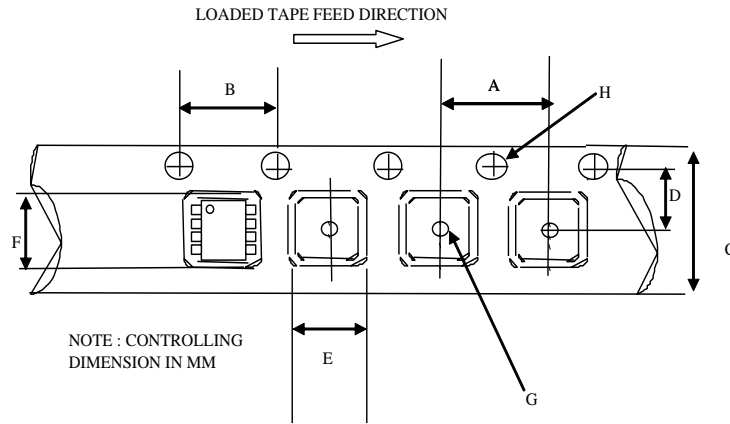
Tape and Reel Details: SO8N

CARRIER TAPE DIMENSION FOR 8SOICN

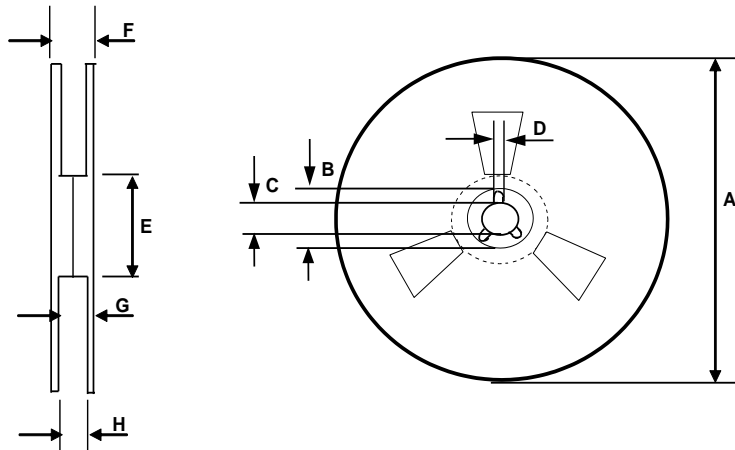
Code	Metric		Imperial	
	Min	Max	Min	Max
A	7.90	8.10	0.311	0.318
B	3.90	4.10	0.153	0.161
C	11.70	12.30	0.46	0.484
D	5.45	5.55	0.214	0.218
E	6.30	6.50	0.248	0.255
F	5.10	5.30	0.200	0.208
G	1.50	n/a	0.059	n/a
H	1.50	1.60	0.059	0.062

REEL DIMENSIONS FOR 8SOICN

Code	Metric		Imperial	
	Min	Max	Min	Max
A	329.60	330.25	12.976	13.001
B	20.95	21.45	0.824	0.844
C	12.80	13.20	0.503	0.519
D	1.95	2.45	0.767	0.096
E	98.00	102.00	3.858	4.015
F	n/a	18.40	n/a	0.724
G	14.50	17.10	0.570	0.673
H	12.40	14.40	0.488	0.566

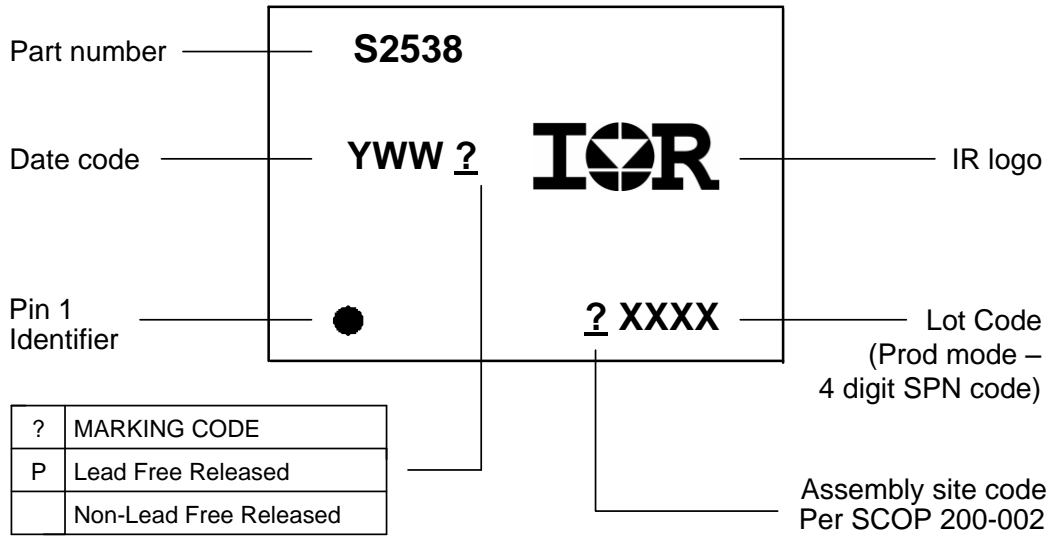
Part Marking Information: SO8N



The information provided in this document is believed to be accurate and reliable. However, International Rectifier assumes no responsibility for the consequences of the use of this information. International Rectifier assumes no responsibility for any infringement of patents or of other rights of third parties which may result from the use of this information. No license is granted by implication or otherwise under any patent or patent rights of International Rectifier. The specifications mentioned in this document are subject to change without notice. This document supersedes and replaces all information previously supplied.

For technical support, please contact IR's Technical Assistance Center
<http://www.irf.com/technical-info/>

WORLD HEADQUARTERS:
 233 Kansas St., El Segundo, California 90245
 Tel: (310) 252-7105

X-ON Electronics

Largest Supplier of Electrical and Electronic Components

Click to view similar products for [Gate Drivers](#) category:

Click to view products by [Infineon](#) manufacturer:

Other Similar products are found below :

[00053P0231](#) [56956](#) [57.404.7355.5](#) [LT4936](#) [57.904.0755.0](#) [5882900001](#) [00600P0005](#) [00-9050-LRPP](#) [00-9090-RDPP](#) [5951900000](#) [01-1003W-10/32-15](#) [0131700000](#) [00-2240](#) [LTP70N06](#) [LVP640](#) [5J0-1000LG-SIL](#) [LY1D-2-5S-AC120](#) [LY2-US-AC240](#) [LY3-UA-DC24](#) [00576P0020](#) [00600P0010](#) [LZN4-UA-DC12](#) [LZNQ2M-US-DC5](#) [LZNQ2-US-DC12](#) [LZP40N10](#) [00-8196-RDPP](#) [00-8274-RDPP](#) [00-8275-RDNP](#) [00-8722-RDPP](#) [00-8728-WHPP](#) [00-8869-RDPP](#) [00-9051-RDPP](#) [00-9091-LRPP](#) [00-9291-RDPP](#) [0207100000](#) [0207400000](#) [01312](#) [0134220000](#) [60713816](#) [M15730061](#) [61161-90](#) [61278-0020](#) [6131-204-23149P](#) [6131-205-17149P](#) [6131-209-15149P](#) [6131-218-17149P](#) [6131-220-21149P](#) [6131-260-2358P](#) [6131-265-11149P](#) [CS1HCPU63](#)